

Features

- Output current greater than 1.5A
- Range Output voltage range adjustable from 1.25V to 37V

Applications

- Power Management for Computer Mother Board, Graphic Card
- LCD Monitor and LCD TV
- DVD Decode Board
- ADSL Modem
- Post Regulators for Switching Supplies

General Description

The LM317 device is an adjustable three-terminal positive-voltage regulator capable of supplying more than 1.5A over an output-voltage range of 1.25V to 37V. LM317 features a very low standby current 1.5mA .

317 is available in SOT89-3, TO220 and SOT223 package.

Block Diagram

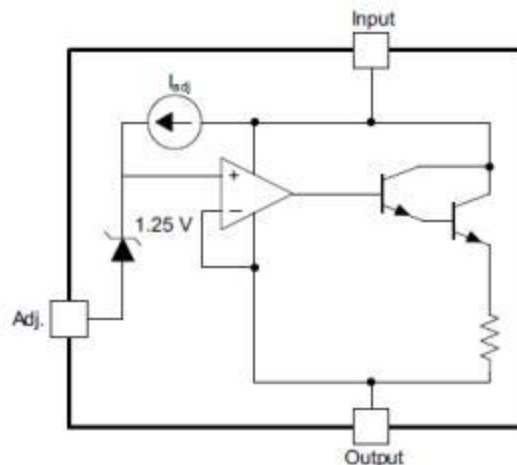

Pin Configuration

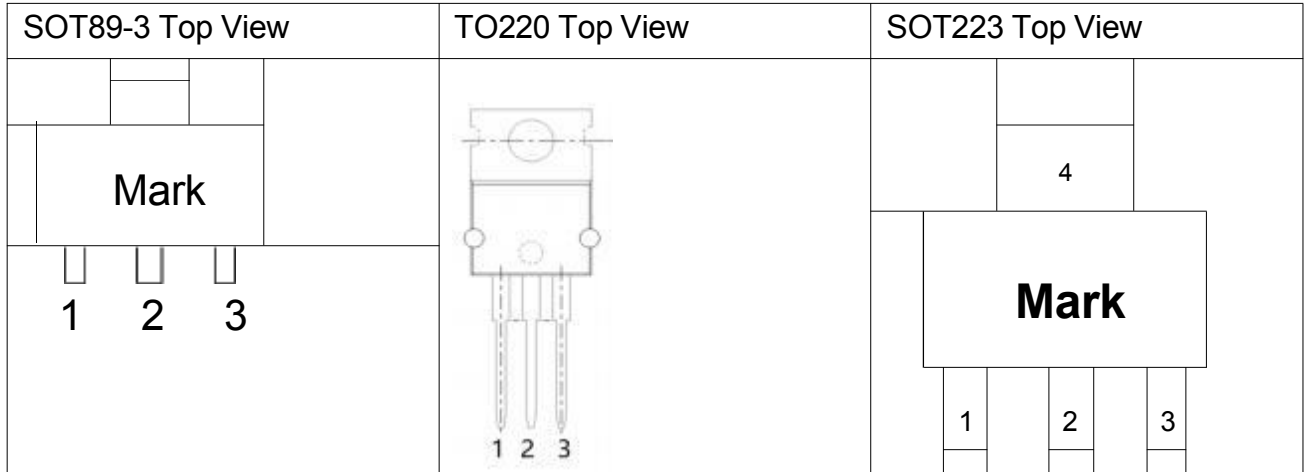

Table1: 317 series (SOT89-3 PKG)

PIN NO.	PIN NAME	FUNCTION
1	ADJ	ADJ pin
2	VOUT	Output voltage pin
3	VIN	Input voltage pin

Table2: 317 series (TO220 PKG)

PIN NO.	PIN NAME	FUNCTION
1	ADJ	ADJ pin
2	VOUT	Output voltage pin
3	VIN	Input voltage pin

Table3: 317 series (SOT223 PKG)

PIN NO.	PIN NAME	FUNCTION
1	ADJ	ADJ pin
2	VOUT	Output voltage pin
3	VIN	Input voltage pin
4	VOUT	Output voltage pin

Absolute Maximum Ratings

Max Input Voltage	40V
Max Operating Junction Temperature(Tj)	150°C
Ambient Temperature(Ta)	-20°C~ 85°C
Storage Temperature(Ts)	-40°C~150°C

Caution: Exceed these limits to damage to the device. Exposure to absolute maximum rating conditions may affect device reliability.

Thermal Information

Symbol	Parameter	TO220	UNIT
$R_{\theta(JA)}$	Junction-to-ambient thermal resistance	37.9	°C/W
$R_{\theta JC(top)}$	Junction-to-case (top) thermal resistance	51.1	°C/W
$R_{\theta JB}$	Junction-to-board thermal resistance	23.2	°C/W
Ψ_{JT}	Junction-to-top characterization parameter	13.0	°C/W
Ψ_{JB}	Junction-to-board characterization parameter	22.8	°C/W
$R_{\theta JC(bot)}$	Junction-to-case (bottom) thermal resistance	4.2	°C/W

Electrical Characteristics

T_A=25°C, unless otherwise noted.

Parameter	Test Conditions	Min	Typ	Max	Unit
Line regulation	V _I -V _O =3V to 40V T _J =25°C	-5	--	5	mV
Load regulation	I _O =10mA to 1500mA	-25	--	25	mV
Reference voltage	V _I - V _O = 3V to 40V, P _D ≤ 20W, I _O =10mA to 1.5A	1.2	1.25	1.3	V
Output-voltage Temperature stability	T _J = 0°C to 125°C		0.7		%V _O
Maximum output current	V _I - V _O ≤ 15V, T _J =25°C	--	1.5	--	A

Detailed Description

317 device is an adjustable three-terminal positive-voltage regulator capable of supplying up to 1.5A over an output-voltage range of 1.25V to 37V. It requires only two external resistors to set the output voltage. The device features a typical line regulation of 1mV and typical load regulation of 7 mV.

The 317 device is versatile in its applications, including uses in programmable output regulation and local on-card regulation. Or, by connecting a fixed resistor between the ADJUST and OUTPUT terminals, the 317 device can function as a precision current regulator. An optional output capacitor can be added to improve transient response.

Typical Application

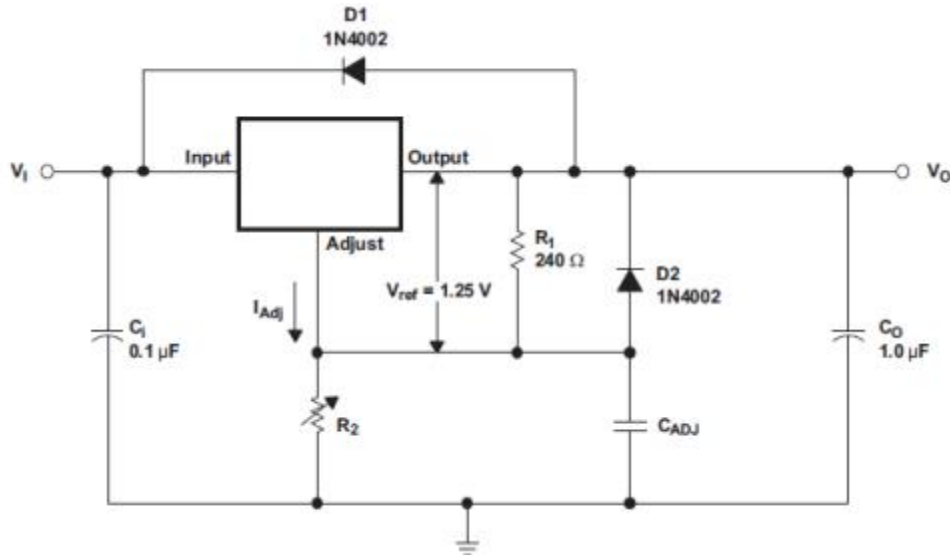

Adjustable Voltage Regulator

1. R₁ and R₂ are required to set the output voltage.
2. C_{ADJ} is recommended to improve ripple rejection. It prevents amplification of the ripple as the output voltage is adjusted higher.
3. C_i is recommended, particularly if the regulator is not in close proximity to the power-supply filter capacitors. A 0.1μF or 1μF ceramic or tantalum capacitor provides sufficient bypassing for most applications, especially when adjustment and output capacitors are used.
4. C_o improves transient response, but is not needed for stability.
5. Protection diode D₂ is recommended if C_{ADJ} is used. The diode provides a low-impedance discharge path to prevent the capacitor from discharging into the output of the regulator.
6. Protection diode D₁ is recommended if C_o is used. The diode provides a low-impedance discharge path to prevent the capacitor from discharging into the output of the regulator.
7. V_o is calculated as shown: $V_o = V_{REF}(1 + R_2/R_1) + (I_{ADJ} \times R_2)$, I_{ADJ} is typically 50μA and negligible in most applications.

Typical Performance Characteristics

Line Transient Response

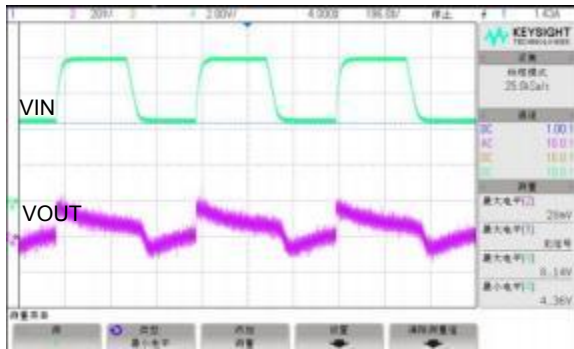

Load Transient Response

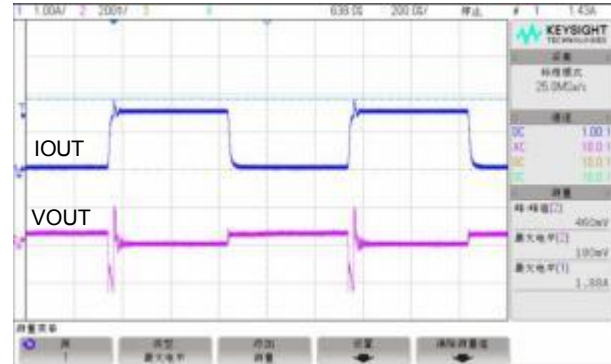

Package Information

SOT89 Package

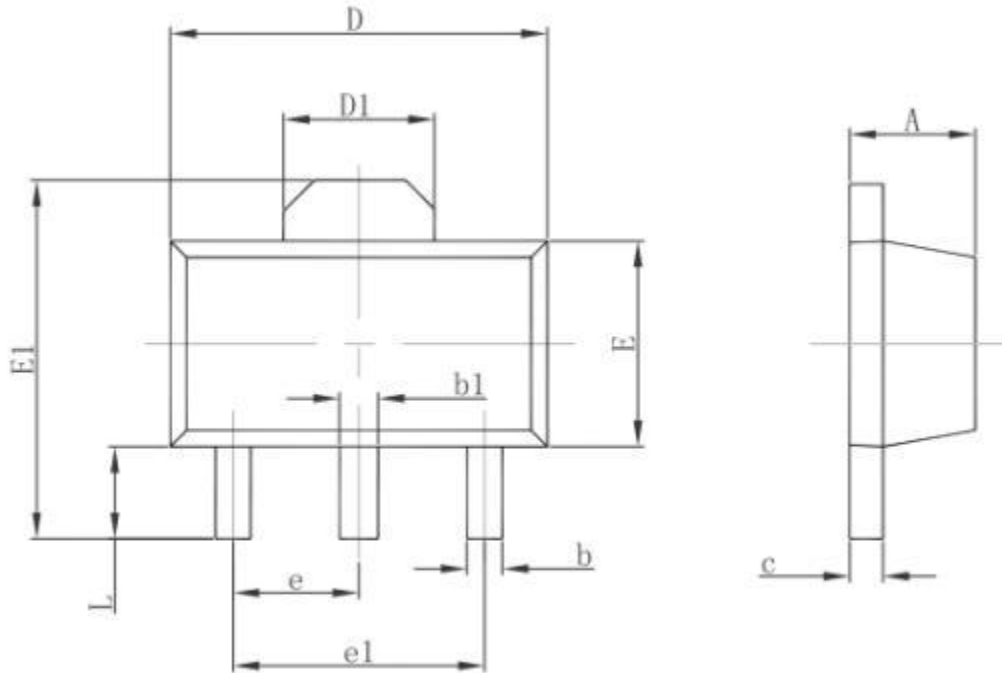

Symbol	Dimensions In Millimeters		Dimensions In Inches	
	Min.	Max.	Min.	Max.
A	1.400	1.600	0.055	0.063
b	0.320	0.520	0.013	0.020
b1	0.400	0.580	0.016	0.023
c	0.350	0.440	0.014	0.017
D	4.400	4.600	0.173	0.181
D1	1.550 REF.		0.061 REF.	
E	2.300	2.600	0.091	0.102
E1	3.940	4.250	0.155	0.167
e	1.500 TYP.		0.060 TYP.	
e1	3.000 TYP.		0.118 TYP.	
L	0.900	1.200	0.035	0.047

TO220 Package

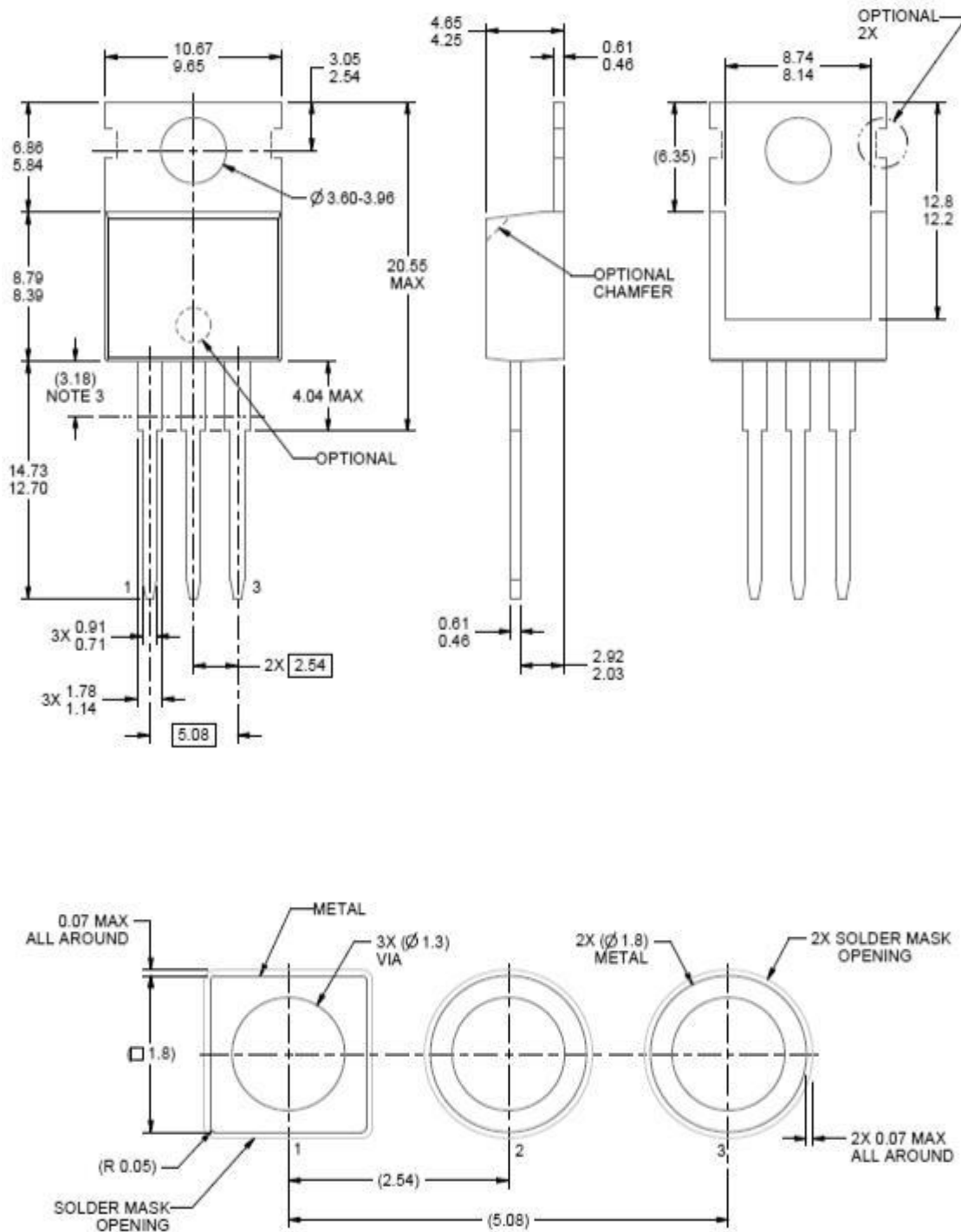

SOT223 Package

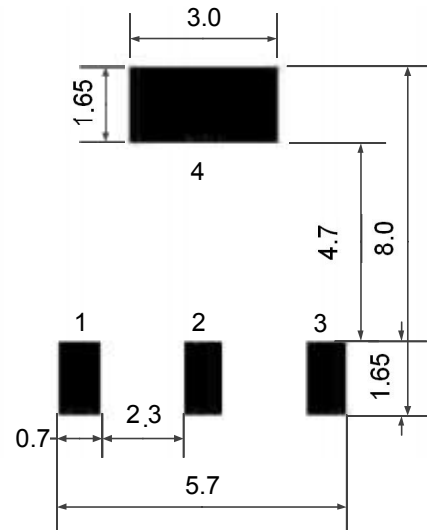
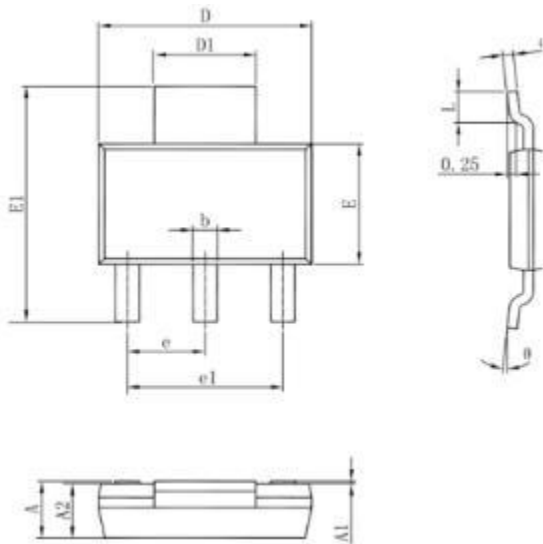

PCB Board

Symbol	Dimensions In Millimeters		Dimensions In Inches	
	Min	Max	Min	Max
A	1.520	1.800	0.060	0.071
A1	0.000	0.100	0.000	0.004
A2	1.500	1.700	0.059	0.067
b	0.660	0.820	0.026	0.032
c	0.250	0.350	0.010	0.014
D	6.200	6.400	0.244	0.252
D1	2.900	3.100	0.114	0.122
E	3.300	3.700	0.130	0.146
E1	6.830	7.070	0.269	0.278
e	2.300(BSC)		0.091(BSC)	
e1	4.500	4.700	0.177	0.185
L	0.900	1.150	0.035	0.045
θ	0°	10°	0°	10°

X-ON Electronics

Largest Supplier of Electrical and Electronic Components

Click to view similar products for [LDO Voltage Regulators](#) category:

Click to view products by [TDSEMIC](#) manufacturer:

Other Similar products are found below :

[AP7363-SP-13](#) [NCV8664CST33T3G](#) [L79M05TL-E](#) [AP7362-HA-7](#) [PT7M8202B12TA5EX](#) [TCR3DF185,LM\(CT](#) [TLF4949EJ](#)
[NCP4687DH15T1G](#) [NCV8703MX30TCG](#) [LP2951CN](#) [NCV4269CPD50R2G](#) [AP7315-25W5-7](#) [NCV47411PAAJR2G](#) [AP2111H-1.2TRG1](#)
[ZLDO1117QK50TC](#) [AZ1117ID-ADJTRG1](#) [NCV4263-2CPD50R2G](#) [NCP114BMX075TCG](#) [MC33269T-3.5G](#) [TLE4471GXT](#) [AP7315-33SA-](#)
[7](#) [NCV4266-2CST33T3G](#) [NCP715SQ15T2G](#) [NCV8623MN-50R2G](#) [NCV563SQ18T1G](#) [NCV8664CDT33RKG](#) [NCV4299CD250R2G](#)
[NCP715MX30TBG](#) [NCV8702MX25TCG](#) [L974113TR](#) [TLE7270-2E](#) [NCV562SQ25T1G](#) [AP2213D-3.3TRG1](#) [AP2202K-2.6TRE1](#)
[NCV8170BMX300TCG](#) [NCV8152MX300180TCG](#) [NCP700CMT45TBG](#) [AP7315-33W5-7](#) [LD56100DPU28R](#) [NCP154MX180300TAG](#)
[AP2210K-3.0TRE1](#) [AP2113AMTR-G1](#) [NJW4104U2-33A-TE1](#) [MP2013AGG-5-P](#) [NCV8775CDT50RKG](#) [NJM2878F3-45-TE1](#) [S-](#)
[19214B00A-V5T2U7](#) [S-19214B50A-V5T2U7](#) [S-19213B50A-V5T2U7](#) [S-19214BC0A-E8T1U7*1](#)