

## 概述 General Description

The TL431 is a three-terminal adjustable shunt regulator with guaranteed thermal stability over a full operation range. It features sharp turn-on characteristics, low temperature coefficient and low output impedance, which make it ideal substitute for Zener diode in applications such as switching power supply, charger and other adjustable regulators.

The output voltage of TL431 can be set to any value between  $V_{ref}$  (2.5V) and the corresponding maximum cathode voltage (36V).

The TL431 is offered in two grade initial voltage tolerance at 25°C, 0.5% and 1%.

This IC is available in 2 packages: TO-92 and SOT-23.

TL431 是三端可调的，全温度范围稳定的并联调整器。具有快速启动、低温漂和低输出阻抗的特性，在开关电源、充电和其他可调调整器应用中是齐纳二极管的理想替代器件。

输出电压范围为  $V_{ref}$  (2.5V) 到最大阴极电压 (36V)。0.5%和 1%两种精度 (25°C)。

封装：TO-92 和 SOT-23。

## 特点 Features

- 可编程精确的输出电压：2.5V - 36V  
Programmable Precise Output Voltage from 2.5V to 36V
- 容性负载下高度稳定  
High Stability Under Capacitive Load
- 低阴极电流，典型值 240μA  
Low Minimum Cathode Current for Regulation: 240μA (Typ.)
- 低温漂，典型值 5 mV  
Low Temperature Deviation: 5mV Typical
- 电流能力：240μA - 100mA  
Sink Current Capacity from 240μA to 100mA
- 宽工作温度范围：-25°C - 125°C  
Wide Operating Range: -25°C to 125°C

## 应用 Applications

- 充电器 Charger
- 电压适配器 Voltage Adapter
- 开关电源 Switching Power supply
- 图形卡 Graphic Card
- 精确电压基准 Precision Voltage Reference



Figure 1. Package Type of TL431

## 管脚排列 Pin Configuration

N Package (SOT-23)

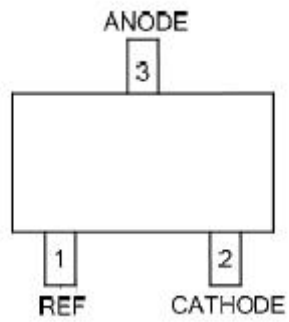

Z Package (T0-92 (Bulk Package))

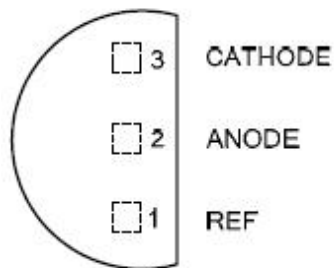

Figure 2. Pin Configuration of TL431 (Top View)

## 功能框图 Functional Block Diagram

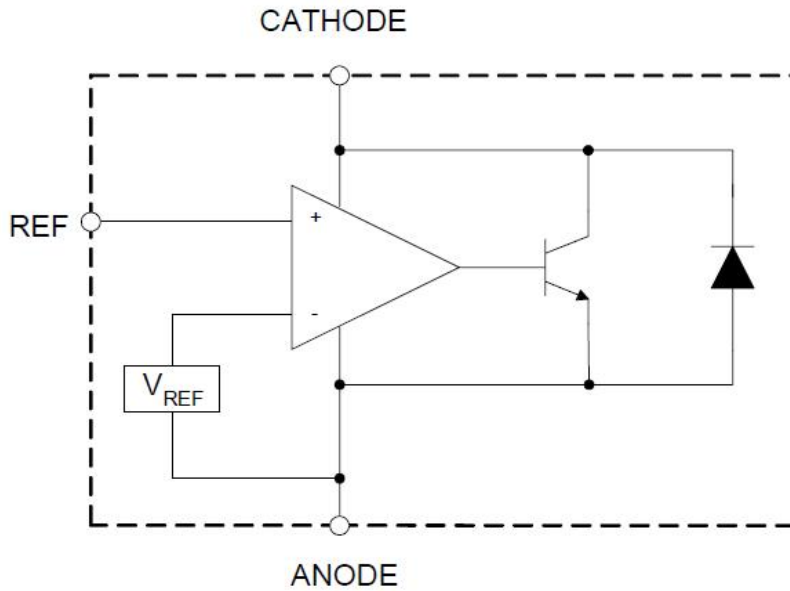

Figure 3. Functional Block Diagram of TL431

## 绝对最大额定值 Absolute Maximum Rating (Note 1)

项目 Parameter	符号 Symbol	数值 Value	单位 Unit
阴极电压 Cathode Voltage	$V_{KA}$	36	V
阴极电流范围 Cathode Current Range	$I_{KA}$	-100 to 150	mA
参考输入电流范围 Reference Input Current Range	$I_{REF}$	10	mA
结温 Junction Temperature	$T_J$	150	°C
存储温度 Storage Temperature Range	$T_{STG}$	-65 to 150	°C
ESD (人体模型) ESD (Human Body Model)	ESD	6000	V
ESD (机器模型) ESD (Machine Model)	ESD	400	V

**Note 1:** Stresses greater than those listed under “Absolute Maximum Ratings” may cause permanent

damage to the device. These are stress ratings only, and functional operation of the device at these or any other conditions beyond those indicated under “Recommended Operating Conditions” is not implied. Exposure to “Absolute Maximum Ratings” for extended periods may affect device reliability.

**备注 1:** 超过“绝对最大额定值”的应力可能会造成器件永久损坏。这些仅是应力额定值，器件工作在上述条件以及超出“建议工作条件”的情况是不可取的。长期处于“绝对最大额定值”可能影响器件的可靠性。

## 环境温度下的额定功耗 Dissipation Rating – Free-air Temperature (Note 2)

Package	Ta=25°C Power Rating	Derating Factor Above Ta=25°C	Ta=70°C Power Rating	Ta=85°C Power Rating
T0-92	700mW	6.2mW/°C	491 mW	398 mW
S0T-23	230mW	1.8mW/°C	149 mW	122 mW

**Note 2:** The safe-work power dissipation of TL431 is under 0.25W while the package is T0-92 which is the ordinary transistor package. Above the power dissipation, the package should be changed to S0 or DIP and the dissipation can be to 0.5W. The margin of power should be enough large because the reference voltage will falls as large power dissipation and high temperature rising. TL431 only is a reference voltage source. It is used to output a stable reference voltage, not large power.

**备注 2:** TL431 的安全使用功率一般设计在 0.25W 以下（T0-92 封装，也就是普通小三极管封装），如果要较大的功率，你可以考虑一下 S0 封装或 DIP 封装的，这两种封装的功率设计为 0.5W 也很稳定。给 TL431 留的功率余量较大，是考虑到 TL431 在大功率，高温升的情况下稳压进度会下降。TL431 只是一种基准电压源，它的最大作用是提供稳定的基准电压，而不是输出大功率。

## 推荐工作条件 Recommended Operating Conditions

项目 Parameter	符号 Symbol	最小值 Min	最大值 Max	单位 Unit
阴极电压 Cathode Voltage	$V_{KA}$	$V_{REF}$	36	V
阴极电流 Cathode Current	$I_{KA}$	0.3	100	mA
工作环境温度 Operating Ambient Temperature Range	$T_A$	-25	125	°C

## 电特性表 Electrical Characteristics

Operating Conditions:  $T_A=25^{\circ}\text{C}$ , unless otherwise specified

工作条件：除非特指，环境温度  $25^{\circ}\text{C}$

项目 Parameter	测试 电路 Test Circ uit	符号 Symbol	测试条件 Conditions	数值 Value			单位 Unit
				最小 Min	典型 Typ	最大 Max	
参考电压 Reference Voltage	4	$V_{REF}$	$V_{KA}=V_{REF}$	2.487	2.500	2.513	V
基准电压温漂 Deviation of Reference Voltage Over Full Temperature Range	4	$\Delta V_{REF}$	$V_{KA}=V_{REF}$ $I_{KA}=10\text{mA}$ $-20^{\circ}\text{C}$ to $110^{\circ}\text{C}$		5	10	mV
基准电压的线性调整率 Ratio of Change in Reference Voltage to the Change in Cathode Voltage	5	$\frac{\Delta V_{REF}}{\Delta V_{KA}}$	$I_{KA}=10\text{mA}$ $V_{KA}=10\text{V}$ to $V_{REF}$ $I_{KA}=10\text{mA}$ $V_{KA}=36\text{V}$ to $10\text{V}$		+0.4		mV/V
					-0.4		
基准电流 Reference Current	5	$I_{REF}$	$I_{KA}=10\text{mA}$ $R_1=10\text{K}\Omega$ $R_2=\infty$		1.0	2.5	$\mu\text{A}$
基准电流温漂 Deviation of Reference Current Over Full Temperature Range	5	$\Delta I_{REF}$	$I_{KA}=10\text{mA}$ $R_1=10\text{K}\Omega$ $R_2=\infty$ $T_A=-10^{\circ}\text{C}$ to $85^{\circ}\text{C}$		0.2	0.4	$\mu\text{A}$
最小阴极电流 Minimum Cathode Current for Regulation	4	$I_{KA}(\text{Min})$	$V_{KA}=V_{REF}$		240	500	$\mu\text{A}$
夹断阴极电流 Off-state Cathode Current	6	$I_{KA}(\text{Off})$	$V_{KA}=36\text{V}$ $V_{REF}=0$		0.08	1	$\mu\text{A}$
动态阻抗 Dynamic Impedance	4	$Z_{KA}$	$V_{KA}=V_{REF}$ $I_{KA}=1$ to $100\text{mA}$ $f \leq 1.0\text{KHz}$		0.15	0.5	$\Omega$
热阻 Thermal Resistance		$\theta_{JC}$	T0-92		68		$^{\circ}\text{C}/\text{W}$
			SOT-89		70		
			SOT-23		113		

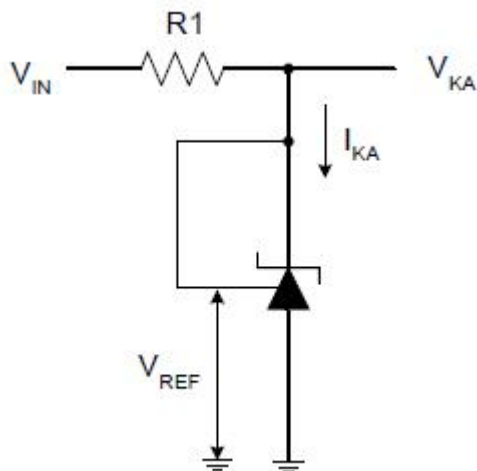

Figure 4. Test Circuit 4 for  $V_{KA}=V_{REF}$

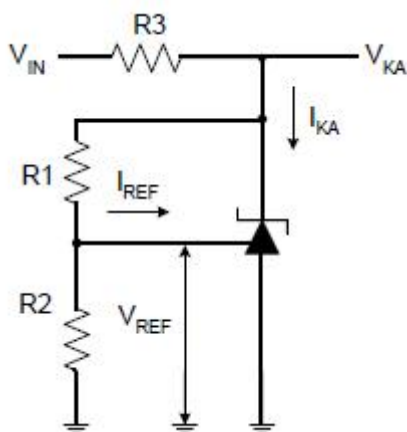

Figure 5. Test Circuit 5 for  $V_{KA}=V_{REF}(1+R_1/R_2)+I_{REF}*R_1$

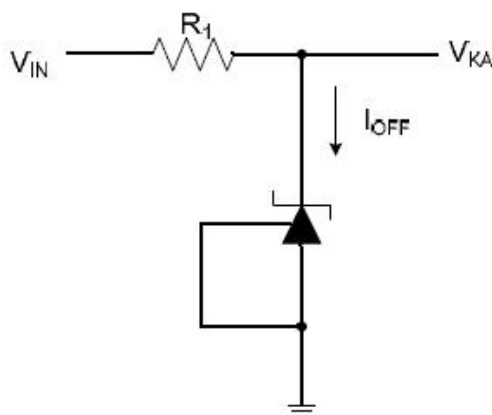

Figure 6. Test Circuit 6 for  $I_{OFF}$

## 典型性能 Typical Performance Characteristics

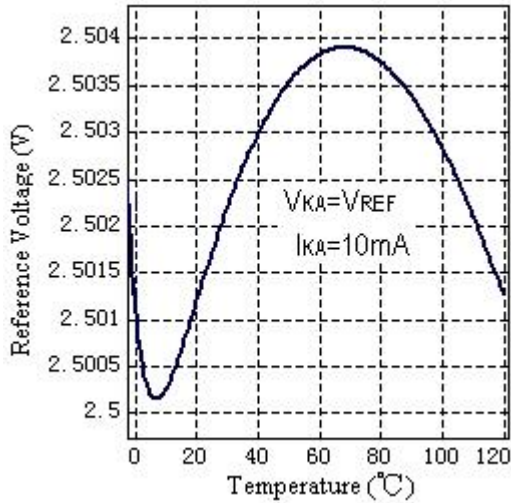

Figure 7. Reference Voltage vs. Ambient Temperature

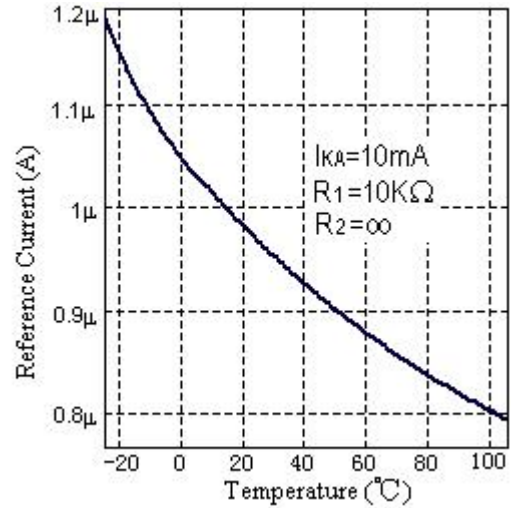

Figure 8. Reference Current vs. Ambient Temperature

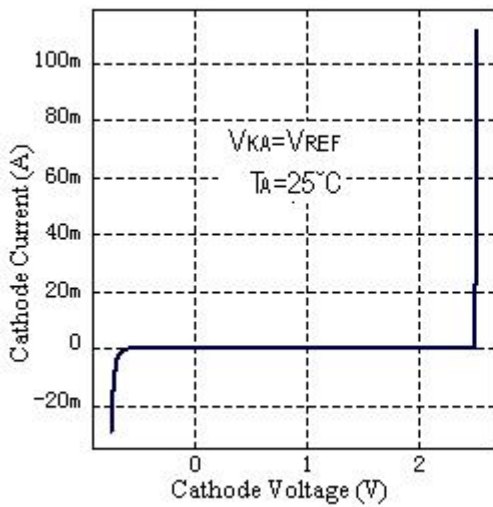

Figure 9. Cathode Current vs. Cathode Voltage

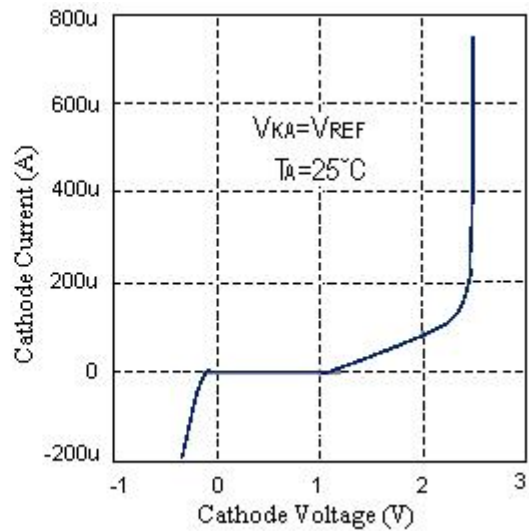

Figure 10. Cathode Current vs. Cathode Voltage

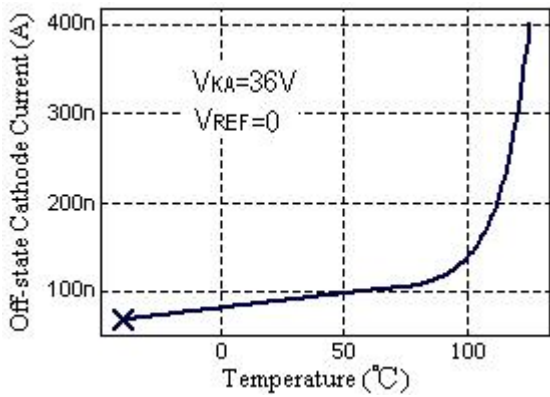

Figure 11. Off-state Cathode Current vs. Ambient Temperature

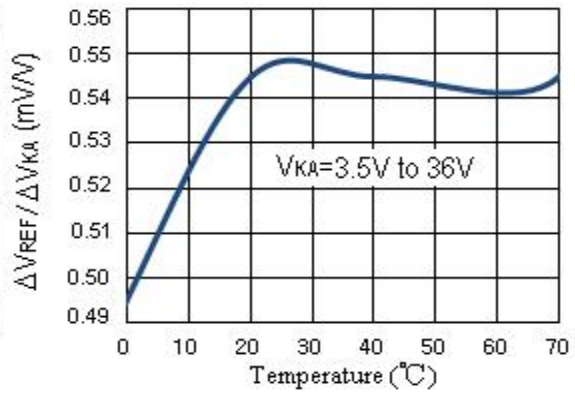

Figure 12. Ratio of Delta Reference Voltage to the Ratio of Delta Cathode Voltage

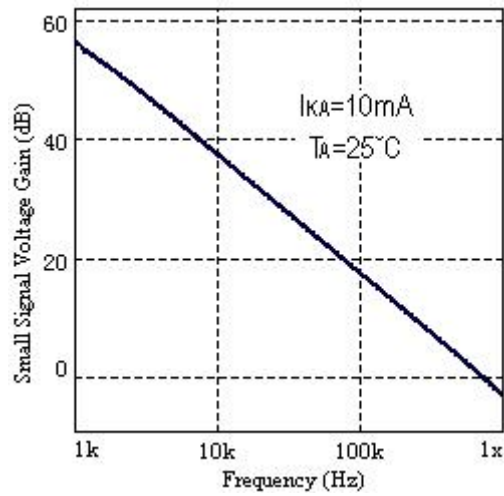
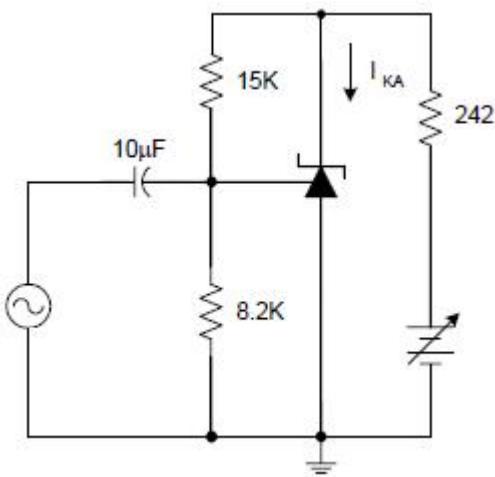

Figure 13. Small Signal Voltage Gain vs. Frequency



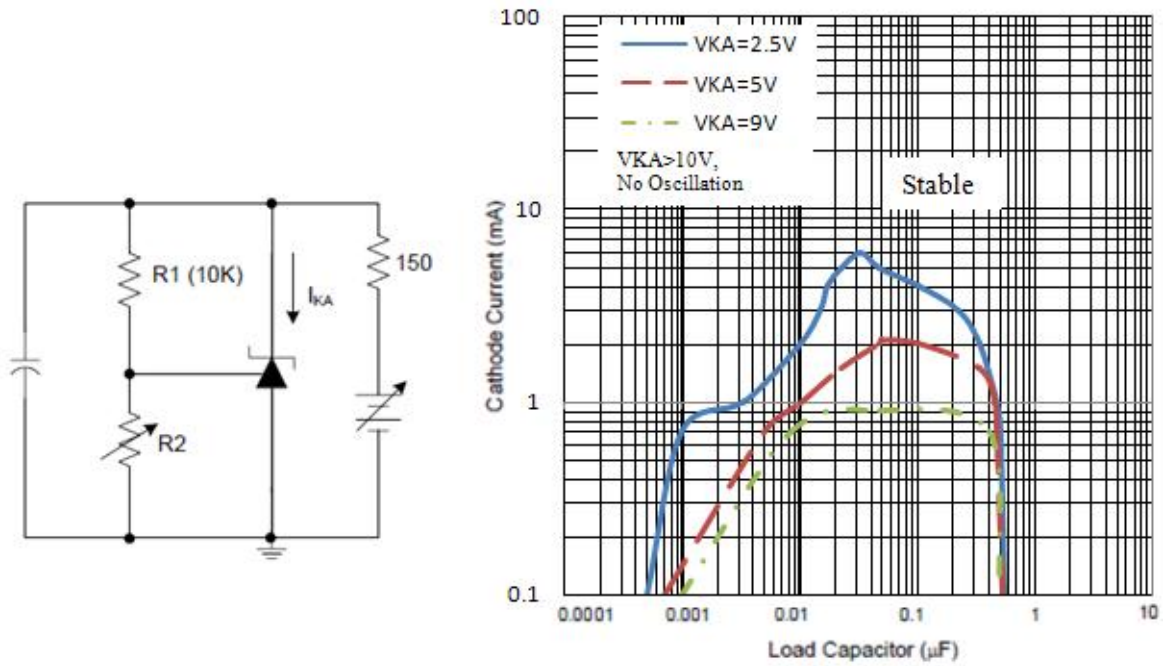

Figure 14. Stability Boundary Conditions vs. Capacitance

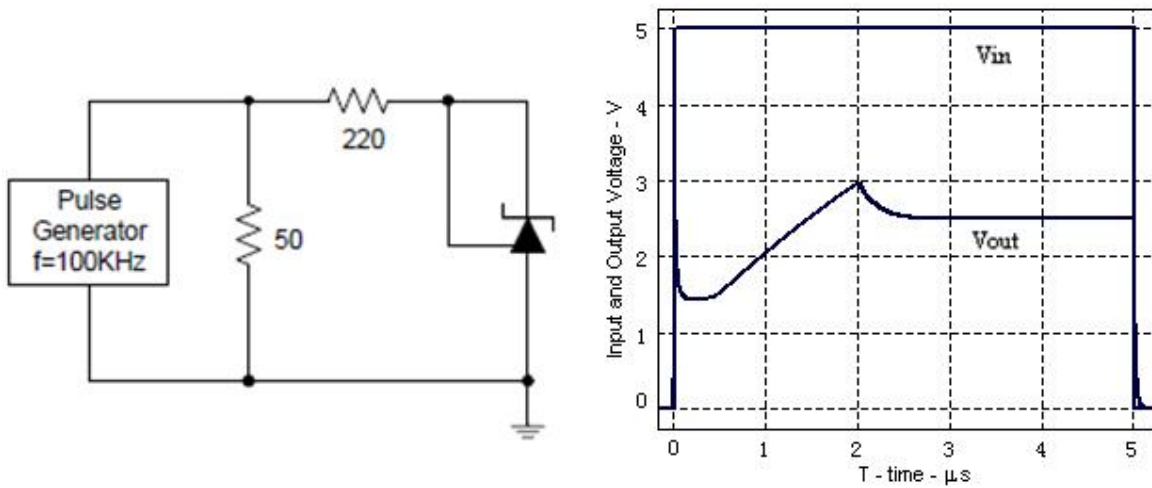

Figure 15. Pulse Response of Input and Output Voltage

## 典型应用 Typical Application

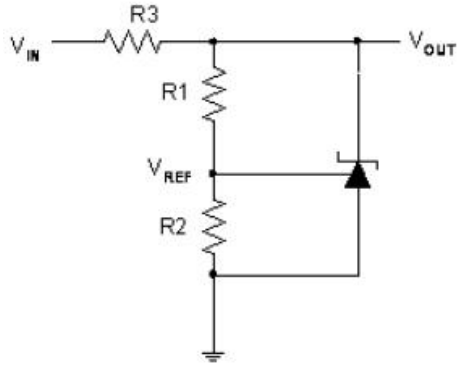

Figure 16. Shunt Regulator

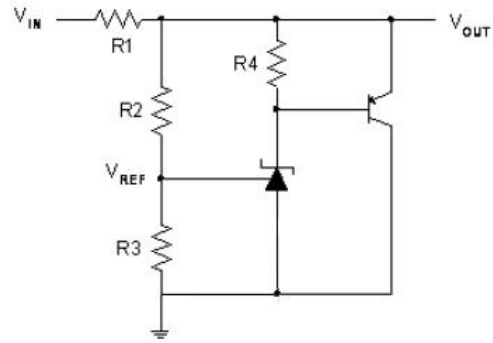

Figure 17. High Current Shunt Regulator

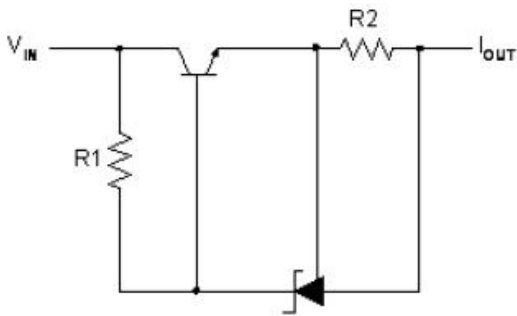

Figure 18. Current Source or Current Limit

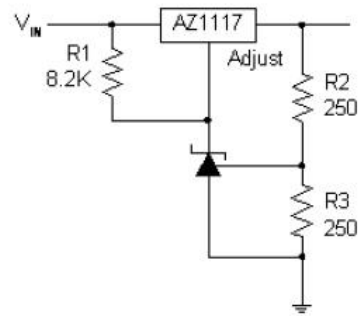

Figure 19. Precision 5V 1A Regulator

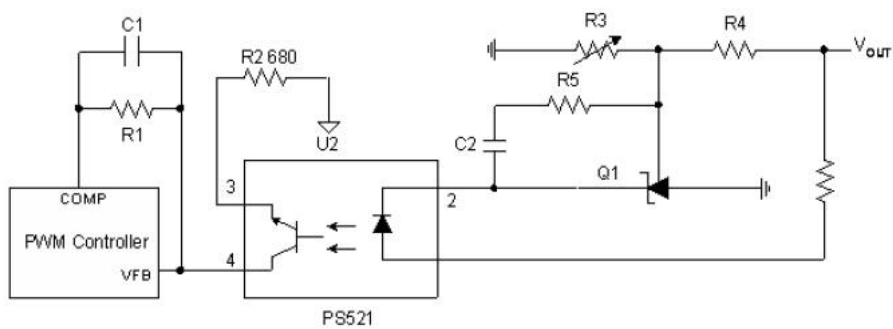

Figure 20. PWM Converter with Reference

**Note 3:** Senichip are responsible for consistency of product. The devices should be working in recommended condition. Before new design product being bulk production, pilot production should be done. Senichip assumes no liability for applications assistance or customer design product.

**备注 3::**

客户应在推荐工作条件下使用器件。客户设计新产品量产前应进行小批量试产，西安晟芯半导体公司不对客户设计产品及其应用支持负责。

## 外观尺寸 Mechanical Dimensions

T0-92 (Bulk Packing)

Unit: mm (inch)

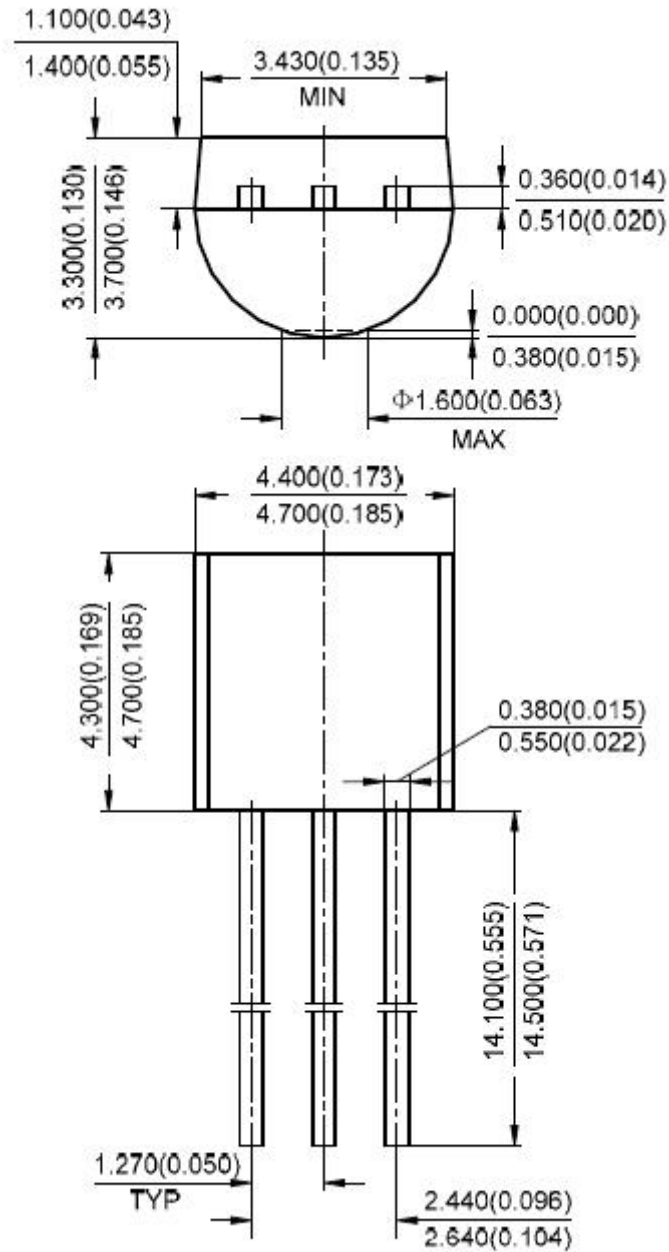

## 外观尺寸 Mechanical Dimensions (Continued)

SOT-23

Unit: mm (inch)

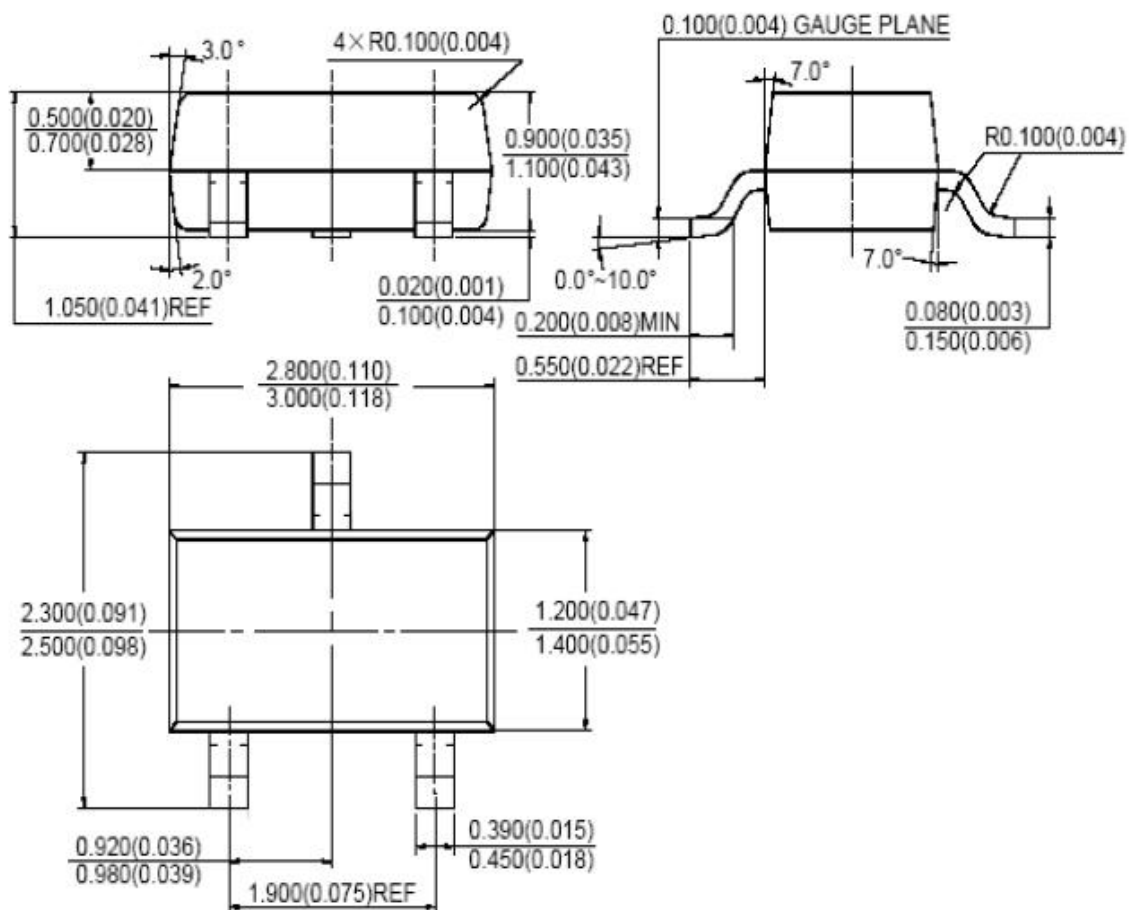

## X-ON Electronics

Largest Supplier of Electrical and Electronic Components

*Click to view similar products for TDSEMIC manufacturer:*

Other Similar products are found below :

[L7805-1.5A](#) [L7806-1.5A](#) [L7912-1.5A](#) [L7812-1.5A](#) [L7915-1.5A](#) [L7808-1.5A](#) [L7815-1.5A](#) [L7905-1.5A](#) [AMS1117-5.0\(SOT89-3\)](#) [HT7144-1](#)  
[AMS1117-1.5](#) [78L08L\(30V\)](#) [XC6206P282PR](#) [HT7125-1](#) [XC6206P362PR](#) [XC6206P332PR](#) [78L05L\(35V\)](#) [LM317](#) [HT7550-1](#)  
[XC6206P302PR](#) [HT7133-1](#) [AMS1117-ADJ\(SOT89-3\)](#) [HT7150-1](#) [AMS1117-1.8\(SOT89-3\)](#) [HT7350-1](#) [HT7525-1](#) [78L05L\(30V\)](#) [HT7130-1](#)  
[HT7330-1](#) [HT7544-1](#) [HT7536-1](#) [HT7333-1](#) [HT7336-1](#) [HT7136-1](#) [LM317\(SOP8\)](#) [AMS1117-3.3](#) [AMS1117-1.8](#) [XC6219B182MR](#) [RT9193-](#)  
[3.0](#) [AMS1117-3.3\(SOT89-3\)](#) [XC6220B331MR](#) [XC6206P282MR](#) [RT9193-1.5](#) [XC6220B181MR](#) [XC6220B251MR](#) [XC6219B362MR](#)  
[XC6220B301MR](#) [XC6220B361MR](#) [XC6220B281MR](#) [XC6219B302MR](#)