

SOT-23 Encapsulate Adjustable Reference Source

TL432 Adjustable Accurate Reference Source

DEVICE DESCRIPTION

The TL432 is a three-terminal Shunt Voltage Reference providing a highly accurate 1.24V. The TL432 thermal stability and wide operating current, makes it suitable for all variety of applications that are looking for a low cost solution with high performance.

FEATURES

- Low dynamic output impedance
- The effective temperature compensation in the working range of full temperature
- Low output noise voltage
- Fast on-state response
- Sink current capability of 0.1mA to 100mA

APPLICATION

- Shunt Regulator
- High-Current Shunt Regulator
- Precision Current Limiter

ABSOLUTE MAXIMUM RATINGS (Operating temperature range applies unless otherwise specified)

Parameter	Symbol	Value	Units
Cathode Voltage	V_{KA}	18	V
Cathode Current Range (continuous)	I_{KA}	100	mA
Reference Input Current Range	I_{ref}	6	μA
Power Dissipation	P_D	350	mW
Thermal Resistance from Junction to Ambient	$R_{\theta JA}$	357	$^{\circ}C/W$
Operating Temperature	T_{opr}	0~+70	$^{\circ}C$
Junction Temperature	T_J	150	$^{\circ}C$
Storage Temperature	T_{stg}	-65~+150	$^{\circ}C$

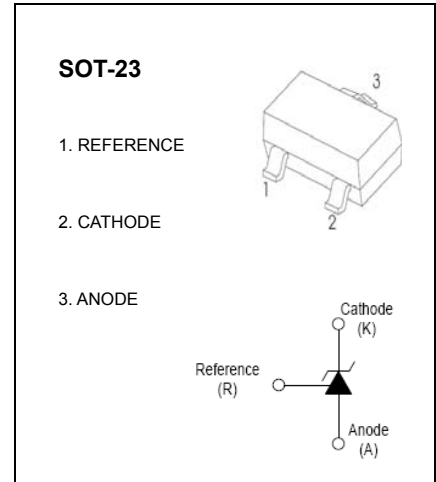

ELECTRICAL CHARACTERISTICS ($T_a=25^{\circ}\text{C}$ unless otherwise specified)

Parameter	Symbol	Test conditions	Min	Typ	Max	Unit
Reference input voltage (Fig 1)	V_{ref}	$V_{\text{KA}}=V_{\text{REF}}, I_{\text{KA}}=10\text{mA}$	1.2214		1.2586	V
Deviation of reference voltage over full temperature range (Fig 1)	$\Delta V_{\text{ref(DEV)}}$	$V_{\text{KA}}=V_{\text{REF}}, I_{\text{KA}}=10\text{mA}$ $0^{\circ}\text{C}\leq T_a\leq 70^{\circ}\text{C}$			16	mV
Ratio of change in reference input voltage to the change in cathode voltage (Fig 2)	$\Delta V_{\text{ref}}/\Delta V_{\text{KA}}$	$I_{\text{KA}}=10\text{mA}$, $\Delta V_{\text{KA}}=1.25\text{V}\sim 15\text{V}$			2.4	mV/V
Deviation of reference input current over full temperature range (Fig 2)	$\Delta I_{\text{ref}}/\Delta T$	$I_{\text{KA}}=10\text{mA}$, $R_1=10\text{k}\Omega$, $R_2=\infty$, $0^{\circ}\text{C}\leq T_a\leq 70^{\circ}\text{C}$			0.6	μA
Minimum cathode current for regulation (Fig 1)	$I_{\text{KA(min)}}$	$V_{\text{KA}}=V_{\text{REF}}$			0.1	mA
Off-state cathode current(Fig 3)	I_{off}	$V_{\text{KA}}=15\text{V}, V_{\text{REF}}=0$			0.5	μA
Dynamic impedance	Z_{KA}	$V_{\text{KA}}=V_{\text{REF}}, I_{\text{KA}}=0.1\sim 20\text{mA}$, $f\leq 1.0\text{kHz}$			0.5	Ω

CLASSIFICATION OF V_{ref}

Rank	1%	1.5%
Range	1.2276~1.2524	1.2214~1.2586

Typical Characteristics

TL432

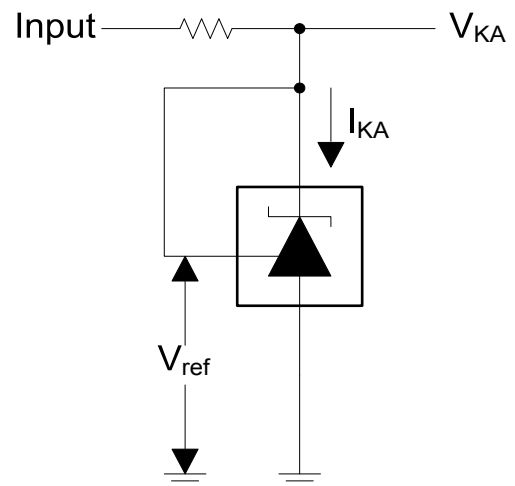
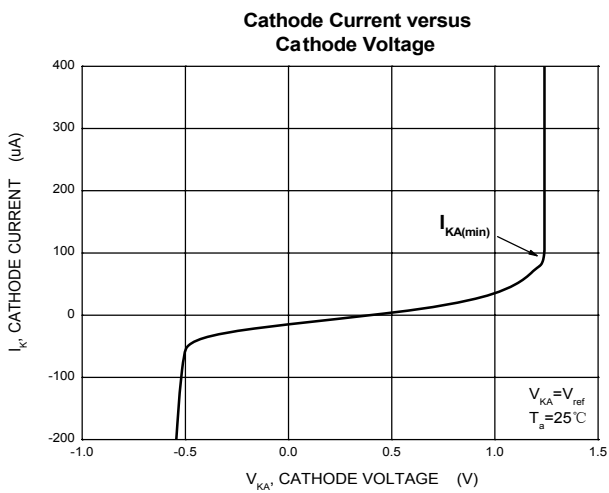
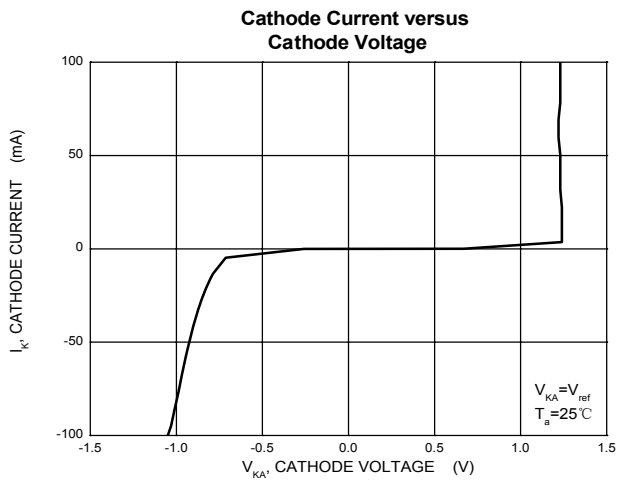

Test Circuit for $V_{KA} = V_{ref}$

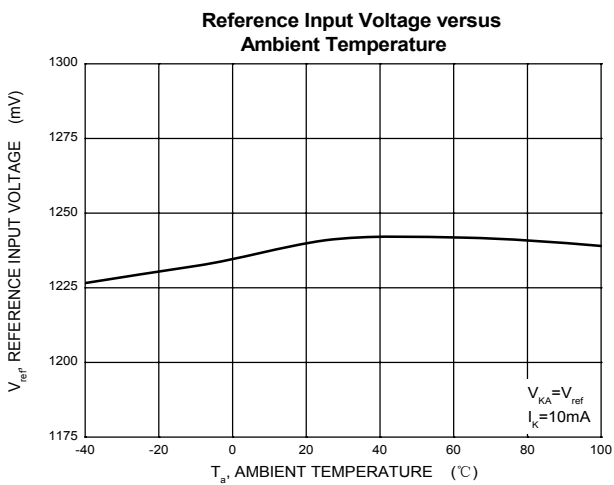

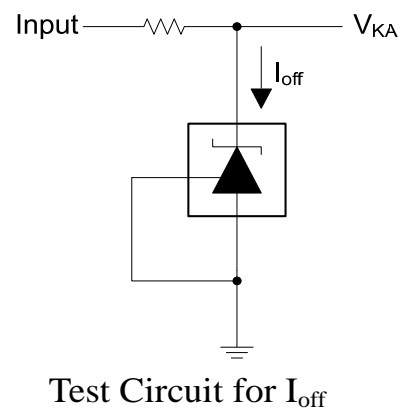
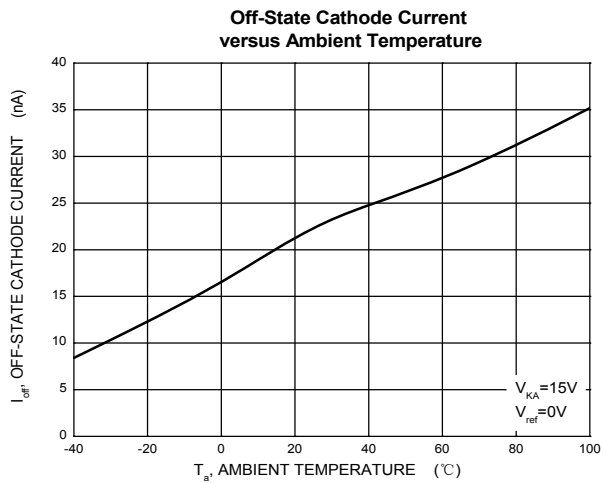
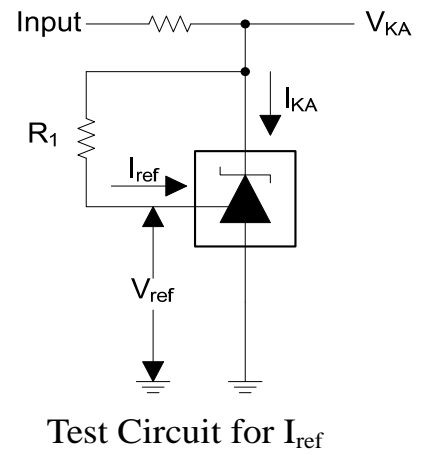
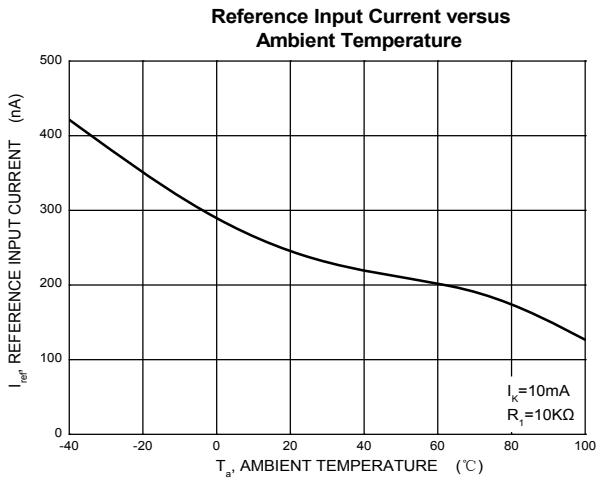
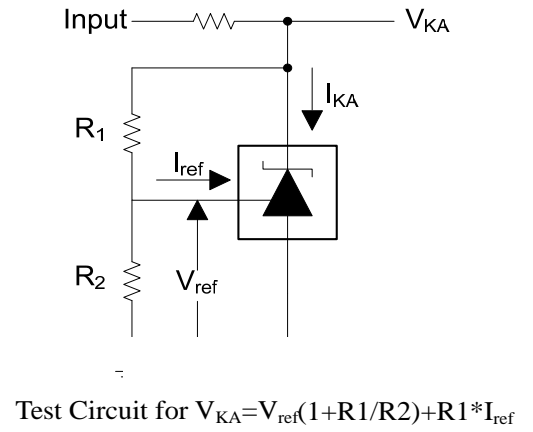
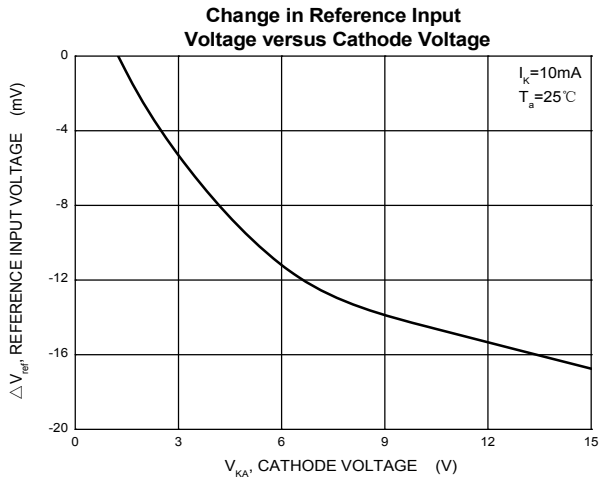

PACKAGE OUTLINE

Plastic surface mounted package; 3 leads

SOT-23

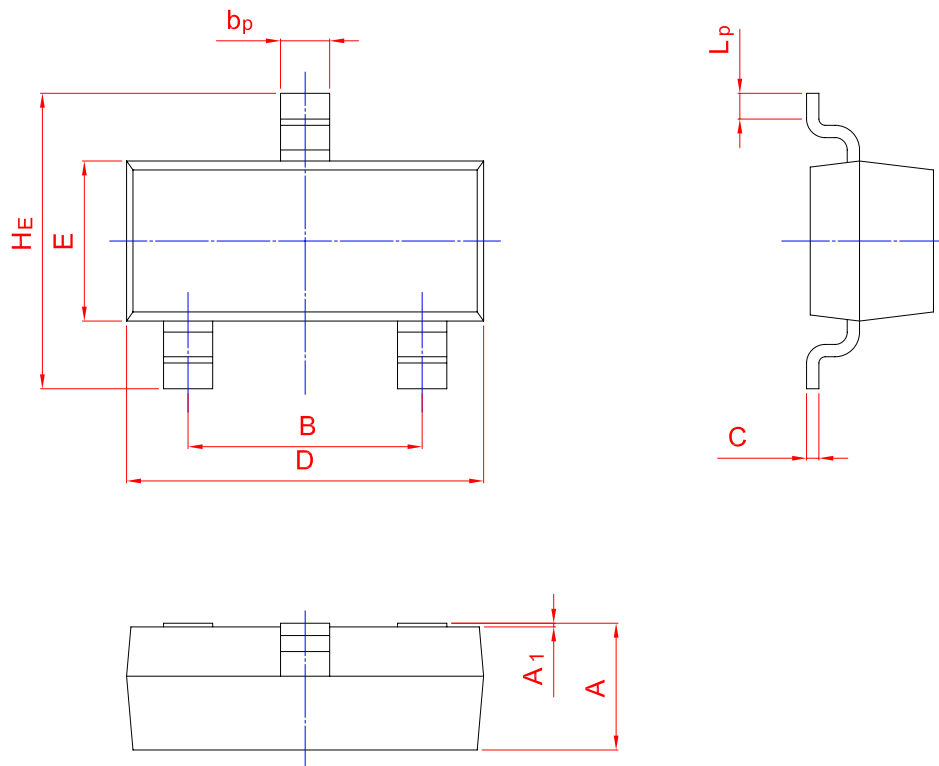
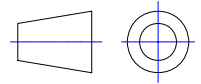

UNIT	A	B	bp	C	D	E	HE	A1	Lp
mm	1.40	2.04	0.50	0.19	3.10	1.65	3.00	0.100	0.50
	0.95	1.78	0.35	0.08	2.70	1.20	2.20	0.013	0.20

X-ON Electronics

Largest Supplier of Electrical and Electronic Components

Click to view similar products for TDSEMIC manufacturer:

Other Similar products are found below :

[L7805-1.5A](#) [L7806-1.5A](#) [L7912-1.5A](#) [L7812-1.5A](#) [L7915-1.5A](#) [L7808-1.5A](#) [L7815-1.5A](#) [L7905-1.5A](#) [AMS1117-5.0\(SOT89-3\)](#) [HT7144-1](#)
[AMS1117-1.5](#) [78L08L\(30V\)](#) [XC6206P282PR](#) [HT7125-1](#) [XC6206P362PR](#) [XC6206P332PR](#) [78L05L\(35V\)](#) [LM317](#) [HT7550-1](#)
[XC6206P302PR](#) [HT7133-1](#) [AMS1117-ADJ\(SOT89-3\)](#) [HT7150-1](#) [AMS1117-1.8\(SOT89-3\)](#) [HT7350-1](#) [HT7525-1](#) [78L05L\(30V\)](#) [HT7130-1](#)
[HT7330-1](#) [HT7544-1](#) [HT7536-1](#) [HT7333-1](#) [HT7336-1](#) [HT7136-1](#) [LM317\(SOP8\)](#) [AMS1117-3.3](#) [AMS1117-1.8](#) [XC6219B182MR](#) [RT9193-](#)
[3.0](#) [AMS1117-3.3\(SOT89-3\)](#) [XC6220B331MR](#) [XC6206P282MR](#) [RT9193-1.5](#) [XC6220B181MR](#) [XC6220B251MR](#) [XC6219B362MR](#)
[XC6220B301MR](#) [XC6220B361MR](#) [XC6220B281MR](#) [XC6219B302MR](#)