

THIS DRAWING IS UNPUBLISHED. RELEASED FOR PUBLICATION  
 © COPYRIGHT copyright.d8te- ALL RIGHTS RESERVED.

REVISIONS				
P	LTR	DESCRIPTION	DATE	APVD
	A	RELEASED FOR PRODUCTION	23OCT2017	RK PO

NOTES:

- 1 LID NOT ASSEMBLED WITH LOWER PART. ENCLOSED LOOSELY
- 2 FLAP NOT ASSEMBLED WITH LOWER PART. ENCLOSED LOOSELY
- 3 PART NUMBER.
- 4 PRODUCTION DATE (YYMMDD)
- 5 MANUFACTURING LOCATION CODE.
- 6 OMEGA CLIP AS LOOSE PIECE IN BOX, PRODUCT SPEC. 108-94176
- 7 MODEL CODE ACCORDING TE-SPEC. 404-74000-1
- 8 CONSECUTIVE SERIAL NUMBER
- 9 TEST EQUIPMENT NUMBER
- 10 DIODES WELDED ON CONTACT RAIL
- 11. MUST COMPLY WITH DIRECTIVE 2002/95/EC (ROHS).
- 12. THIS PRODUCT HAS NOT COMPLETED VALIDATION TESTING.

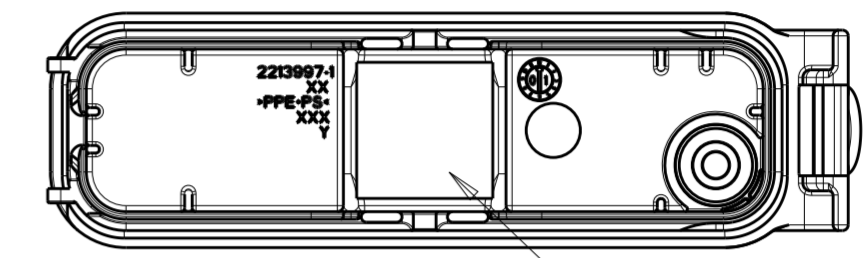
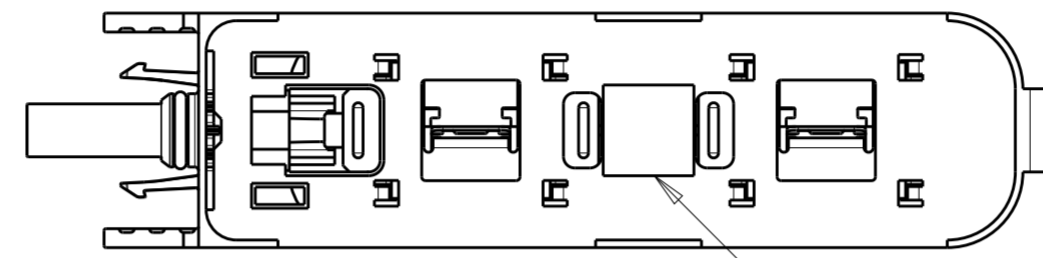

BOTTOM VIEW OF TYPICAL ASSEMBLY WHEN MOUNTING TAPE IS APPLIED

BOTTOM VIEW OF LID SUBASSEMBLY WHEN THERMAL INTERFACE MATERIAL IS APPLIED

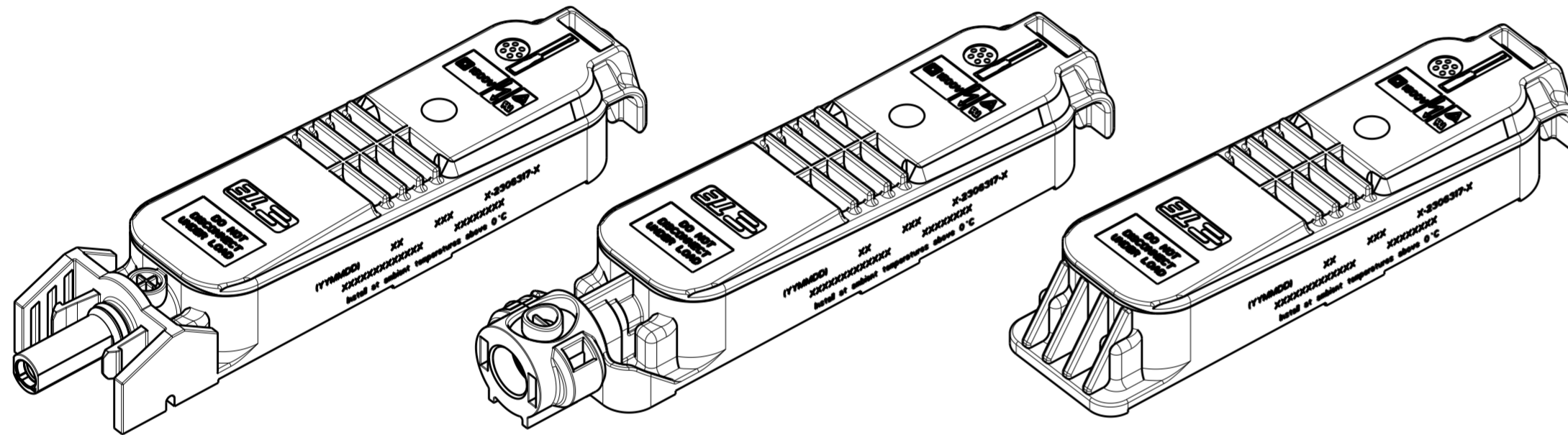

PVEDGE2GGA1V_2	36.0	EAST/WEST	YES	YES	7-2306317-5
PVEDGE2DGA1V_2	55.2	EAST/WEST	YES	YES	7-2306317-2
PVEDGE2FGA1V_2	58.7	EAST/WEST	YES	YES	7-2306317-1
PVEDGE2GGA1V_2	36.0	EAST/WEST	NO	YES	6-2306317-5
PVEDGE2DGA1V_2	55.2	EAST/WEST	NO	YES	6-2306317-2
PVEDGE2FGA1V_2	58.7	EAST/WEST	NO	YES	6-2306317-1
PVEDGE2GGA1T_2	36.0	EAST/WEST	YES	NO	5-2306317-5
PVEDGE2DGA1T_2	55.2	EAST/WEST	YES	NO	5-2306317-2
PVEDGE2FGA1T_2	58.7	EAST/WEST	YES	NO	5-2306317-1
PVEDGE2GGA1T_2	36.0	EAST/WEST	NO	NO	4-2306317-5
PVEDGE2DGA1T_2	55.2	EAST/WEST	NO	NO	4-2306317-2
PVEDGE2FGA1T_2	58.7	EAST/WEST	NO	NO	4-2306317-1
PVEDGE2GGA1V_2	36.0	NORTH/SOUTH	YES	YES	3-2306317-5
PVEDGE2DGA1V_2	55.2	NORTH/SOUTH	YES	YES	3-2306317-2
PVEDGE2FGA1V_2	58.7	NORTH/SOUTH	YES	YES	3-2306317-1
PVEDGE2GGA1V_2	36.0	NORTH/SOUTH	NO	YES	2-2306317-5
PVEDGE2DGA1V_2	55.2	NORTH/SOUTH	NO	YES	2-2306317-2
PVEDGE2FGA1V_2	58.7	NORTH/SOUTH	NO	YES	2-2306317-1
PVEDGE2GGA1T_2	36.0	NORTH/SOUTH	YES	NO	1-2306317-5
PVEDGE2DGA1T_2	55.2	NORTH/SOUTH	YES	NO	1-2306317-2
PVEDGE2FGA1T_2	58.7	NORTH/SOUTH	YES	NO	1-2306317-1
PVEDGE2GGA1T_2	36.0	NORTH/SOUTH	NO	NO	2306317-5
PVEDGE2DGA1T_2	55.2	NORTH/SOUTH	NO	NO	2306317-2
PVEDGE2FGA1T_2	58.7	NORTH/SOUTH	NO	NO	2306317-1

TIN OVER NICKEL	COPPER ALLOY	INTERFACE CONTACT-SOCKET	11
TIN OVER NICKEL	COPPER ALLOY	INTERFACE CONTACT-PIN	10
-	-	THERMAL INTERFACE MATERIAL	9
-	-	BYPASS DIODE: TYPE SL2020A	8
GRAY	PPE+PS	MEMBRANE RETAINER	7
-	-	MEMBRANE VENT	6
PLAIN	STAINLESS STEEL	OMEGA CLIP	5 <sup>6</sup>
TIN	COPPER ALLOY	CONTACT RAIL	4
BLACK	PPE+PS	BOX, LOWER HOUSING	3
RED	SILICONE	O-RING SEAL	2
BLACK	PPE+PS	BOX, LID	1 <sup>1</sup>
COLOR/FINISH	MATERIAL	DESCRIPTION	ITEM NO.

THIS DRAWING IS A CONTROLLED DOCUMENT.		DWN RAVLS 13AUG2016	TE Connectivity	
DIMENSIONS: mm		CHK GINGRICH CHUCK 13AUG2016		
TOLERANCES UNLESS OTHERWISE SPECIFIED:		APVD GINGRICH CHUCK 13AUG2016	NAME PV EDGE ASSEMBLY, WITHOUT FLAP, OMEGA CLIP	
0 PLC ±0.50		PRODUCT SPEC 108-32122	SIZE A2	
1 PLC ±0.25		APPLICATION SPEC 114-32157	CAGE CODE G-2306317	
2 PLC ±0.13		WEIGHT -	DRAWING NO. C-2306317	
3 PLC ±		CUSTOMER DRAWING	RESTRICTED TO -	
4 PLC ANGLES ±		SCALE 1:1	SHEET 1 OF 4	
FINISH -		REV A		

THIS DRAWING IS UNPUBLISHED. RELEASED FOR PUBLICATION  
 © COPYRIGHT copyright.d8te- ALL RIGHTS RESERVED.

REVISIONS				
P	LTR	DESCRIPTION	DATE	APVD
-		SEE SHEET 1	-	-

LID NOT SHOWN FOR REFERENCE ONLY

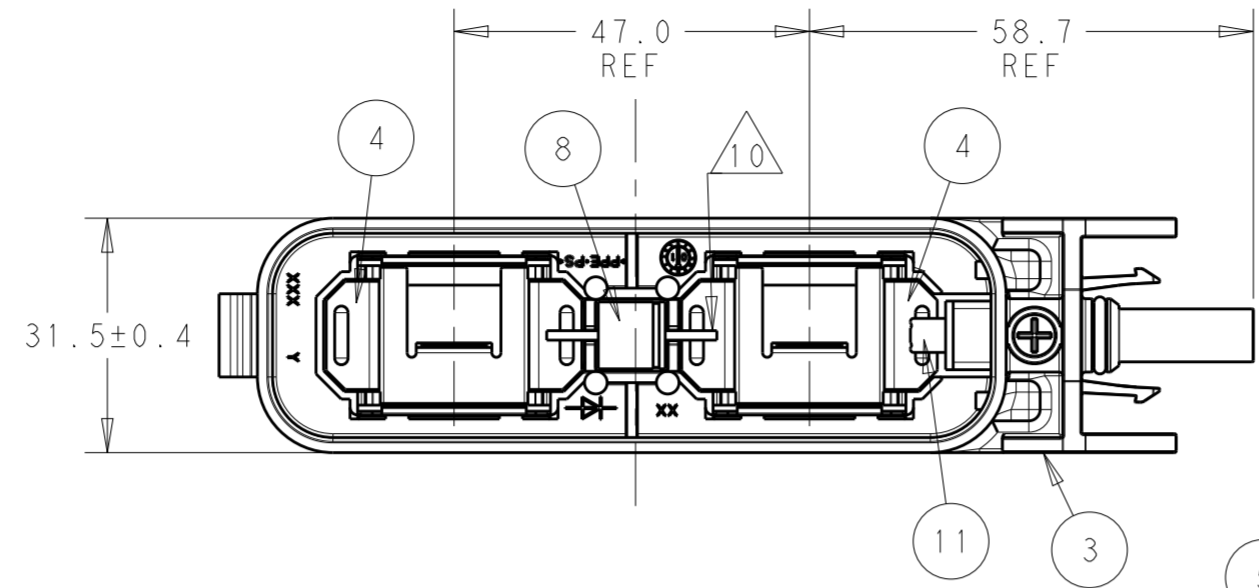

LID NOT SHOWN FOR REFERENCE ONLY

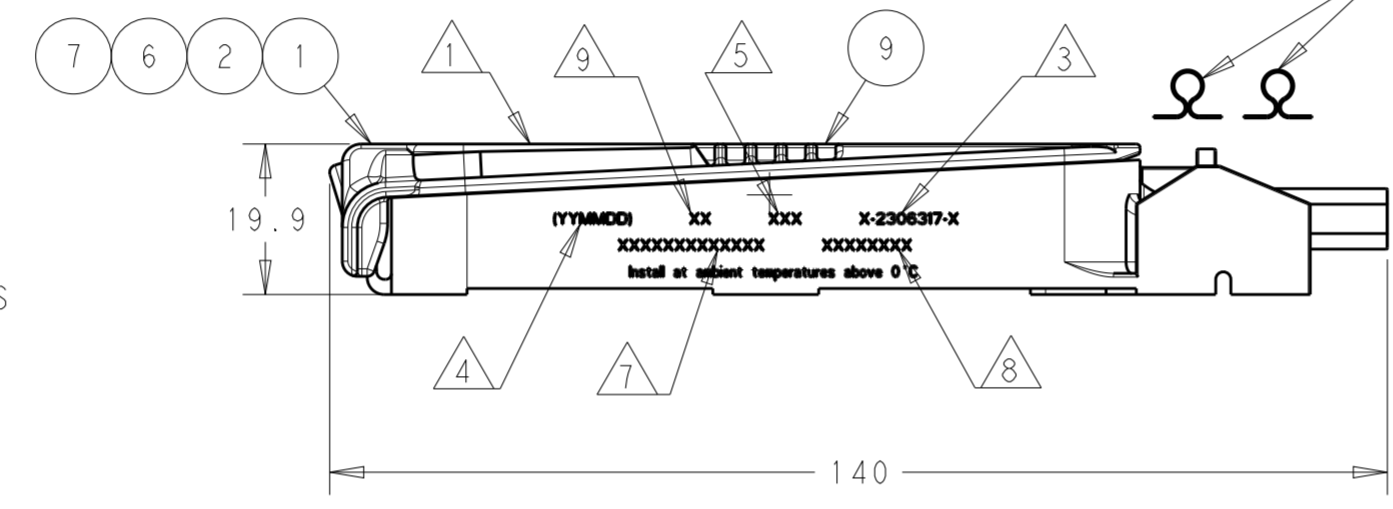
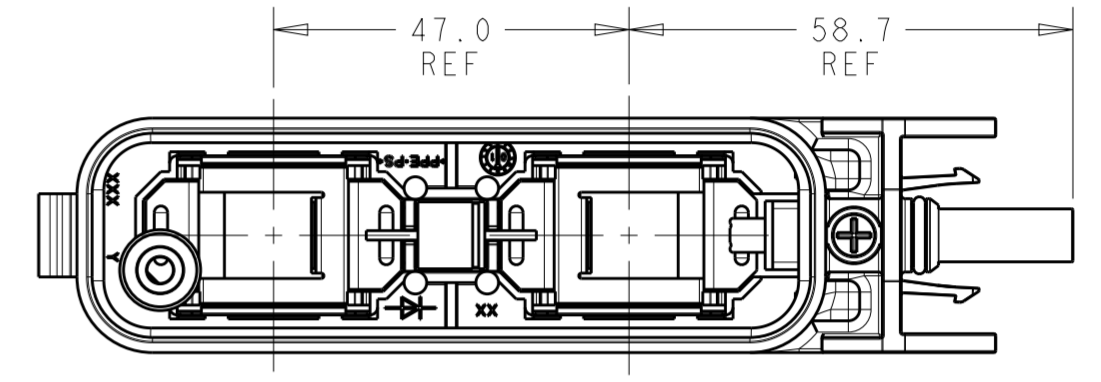

NORTH-SOUTH VERSIONS  
 2306317-1  
 1-2306317-1  
 2-2306317-1  
 3-2306317-1  
 SHOWN

EAST-WEST VERSIONS  
 4-2306317-1  
 5-2306317-1  
 6-2306317-1  
 7-2306317-1  
 SAME AS N-S VERSIONS  
 EXCEPT AS SHOWN

LID NOT SHOWN FOR REFERENCE ONLY

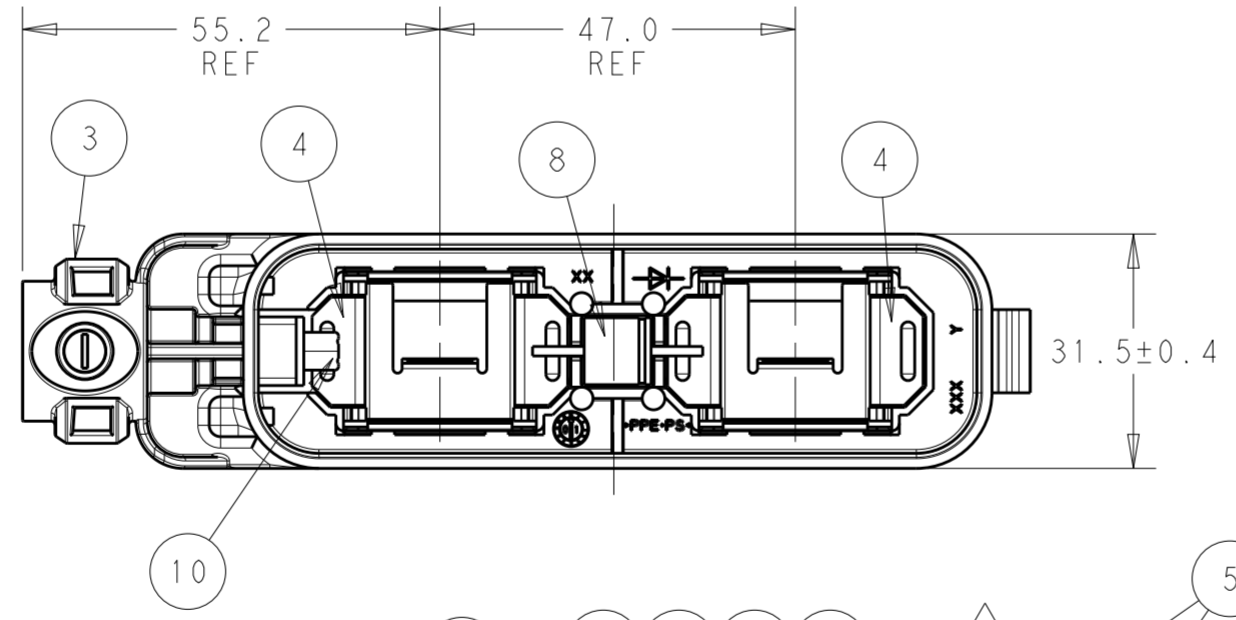

LID NOT SHOWN FOR REFERENCE ONLY

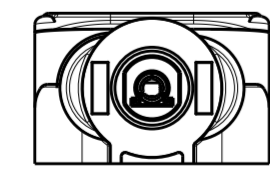
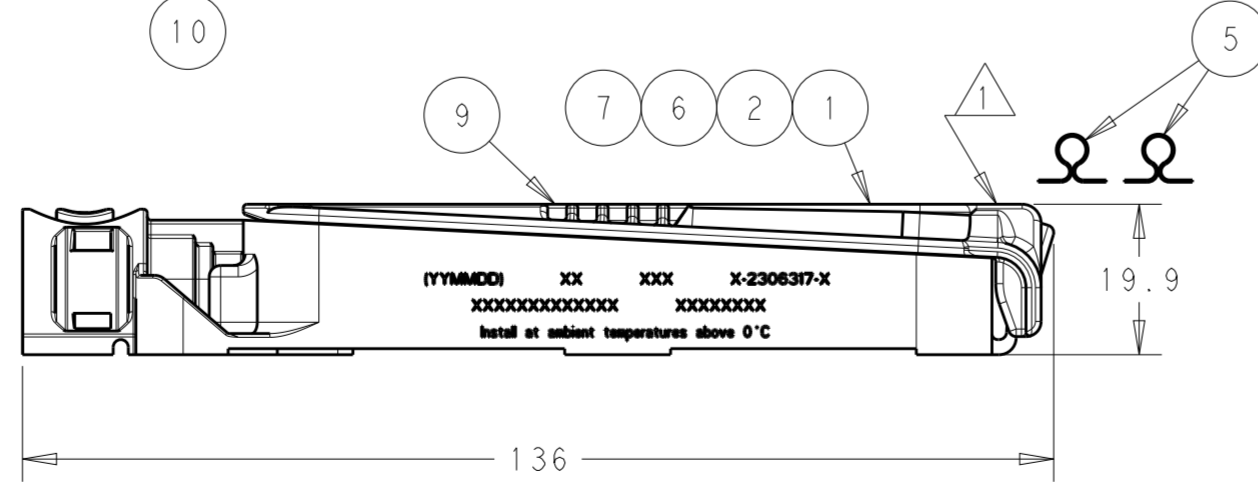
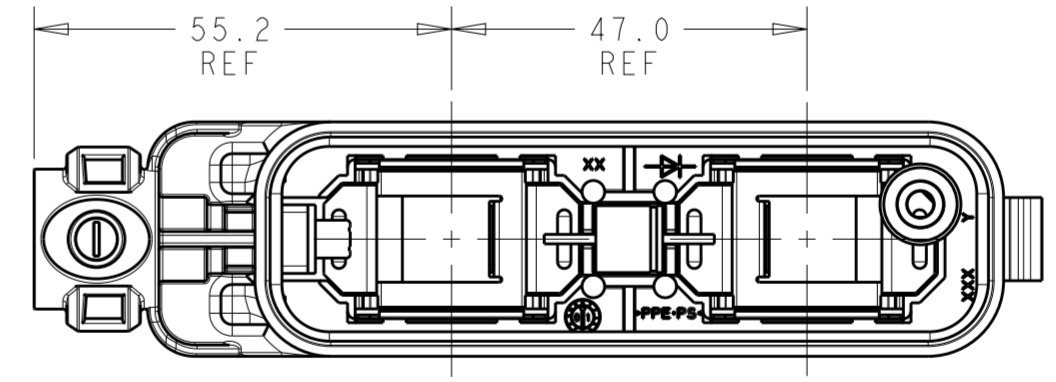

NORTH-SOUTH VERSIONS  
 2306317-2  
 1-2306317-2  
 2-2306317-2  
 3-2306317-2  
 SHOWN

EAST-WEST VERSIONS  
 4-2306317-2  
 5-2306317-2  
 6-2306317-2  
 7-2306317-2  
 SAME AS N-S VERSIONS  
 EXCEPT AS SHOWN

THIS DRAWING IS A CONTROLLED DOCUMENT.		DWN RAVLS 13AUG2016	TE Connectivity	
DIMENSIONS: mm		CHK GINGRICH CHUCK 13AUG2016		
TOLERANCES UNLESS OTHERWISE SPECIFIED:		APVD GINGRICH CHUCK 13AUG2016	NAME PV EDGE ASSEMBLY, WITHOUT FLAP, OMEGA CLIP	
0 PLC ±0.50		PRODUCT SPEC 108-32122	SIZE A2	
1 PLC ±0.25		APPLICATION SPEC 114-32157	CAGE CODE C-2306317	
2 PLC ±0.13		WEIGHT -	DRAWING NO -	
3 PLC ±		CUSTOMER DRAWING	RESTRICTED TO -	
4 PLC ±		SCALE 5:1	SHEET 2 OF 4	
ANGLES ±			REV A	
FINISH -				

THIS DRAWING IS UNPUBLISHED. RELEASED FOR PUBLICATION  
 © COPYRIGHT copyright.d8te- ALL RIGHTS RESERVED.

REVISIONS				
P	LTR	DESCRIPTION	DATE	APVD
-		SEE SHEET 1	-	-

LID NOT SHOWN FOR REFERENCE ONLY

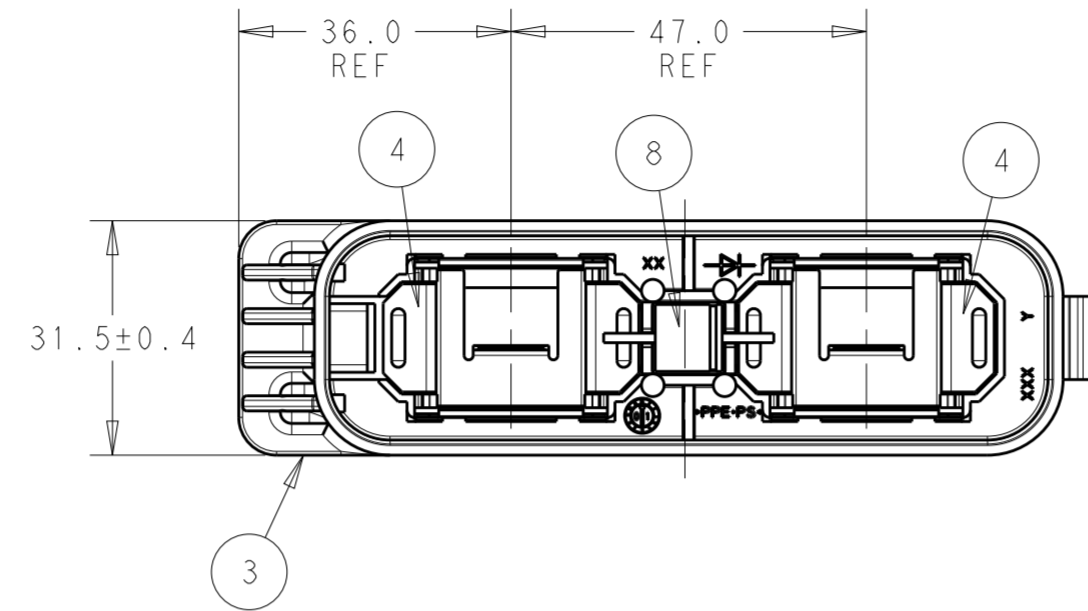

LID NOT SHOWN FOR REFERENCE ONLY

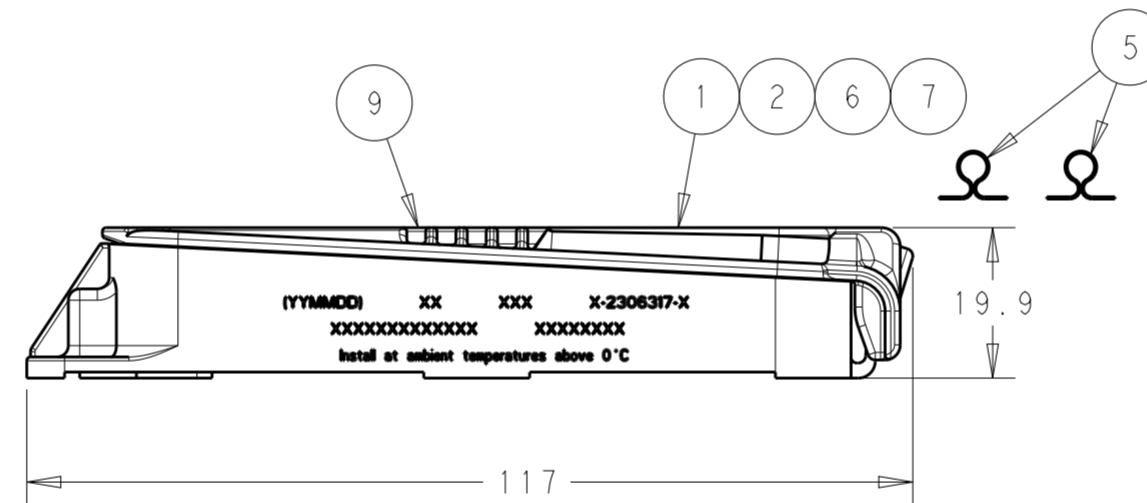
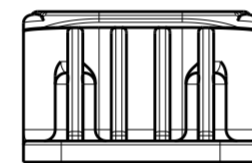
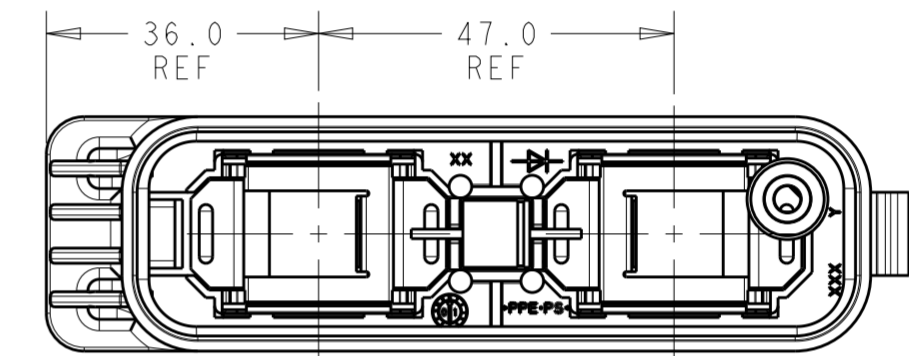

EAST-WEST VERSIONS  
 4-2306317-5  
 5-2306317-5  
 6-2306317-5  
 7-2306317-5  
 SAME AS N-S VERSIONS  
 EXCEPT AS SHOWN

NORTH-SOUTH VERSIONS  
 2306317-5  
 1-2306317-5  
 2-2306317-5  
 3-2306317-5  
 SHOWN

THIS DRAWING IS A CONTROLLED DOCUMENT.		DWN RAVLS 13AUG2016	 TE Connectivity	
DIMENSIONS: mm		CHK GINGRICH CHUCK 13AUG2016		
TOLERANCES UNLESS OTHERWISE SPECIFIED:		APVD GINGRICH CHUCK 13AUG2016	NAME PV EDGE ASSEMBLY, WITHOUT FLAP, OMEGA CLIP	
0 PLC ±0.50		PRODUCT SPEC 108-32122	RESTRICTED TO	
1 PLC ±0.25		APPLICATION SPEC 114-32157	SIZE A2	CAGE CODE C-2306317
2 PLC ±0.13		WEIGHT -	SCALE 5:1	SHEET 3 OF 4
3 PLC ±		CUSTOMER DRAWING	REV A	
4 PLC ±				
ANGLES ±				
FINISH -				

THIS DRAWING IS UNPUBLISHED. RELEASED FOR PUBLICATION  
 © COPYRIGHT copyright.d8te- ALL RIGHTS RESERVED.

REVISIONS				
P	LTR	DESCRIPTION	DATE	APVD
-	-	SEE SHEET 1	-	-

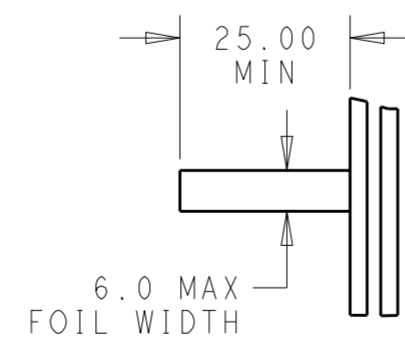
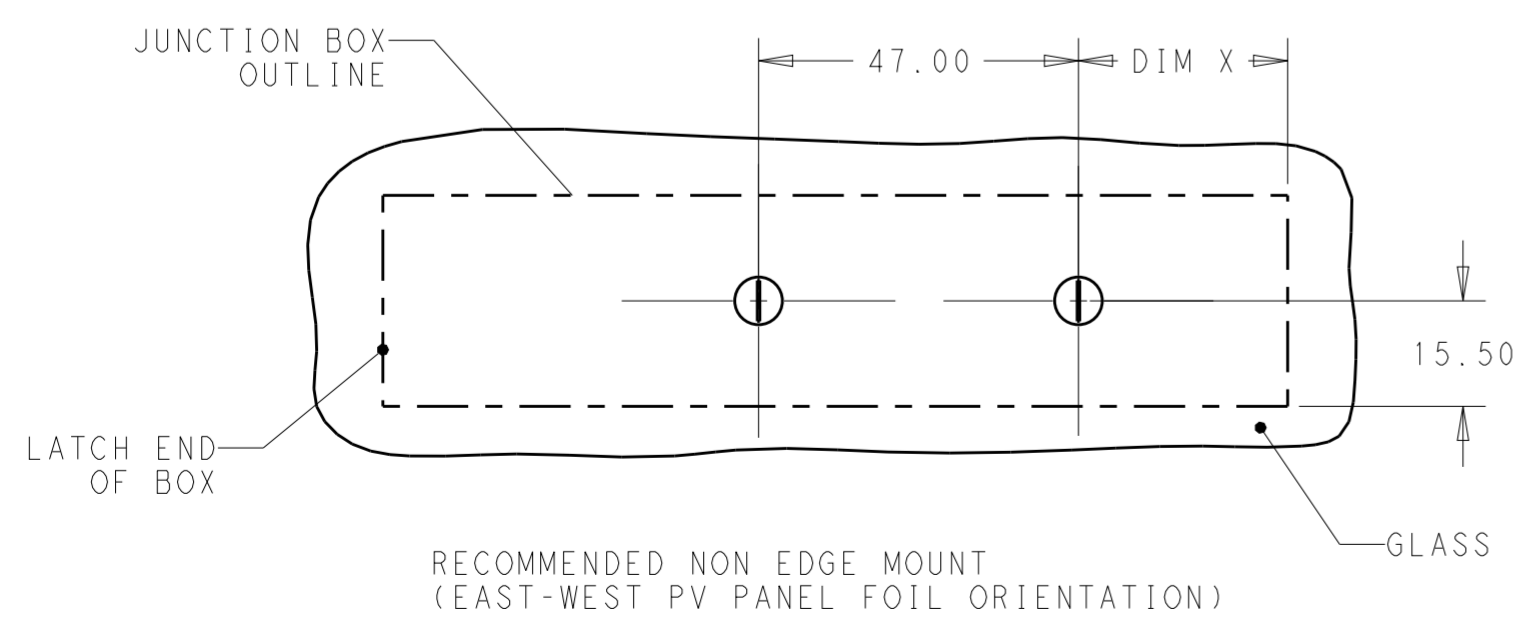
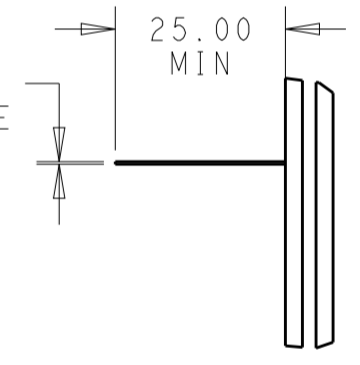
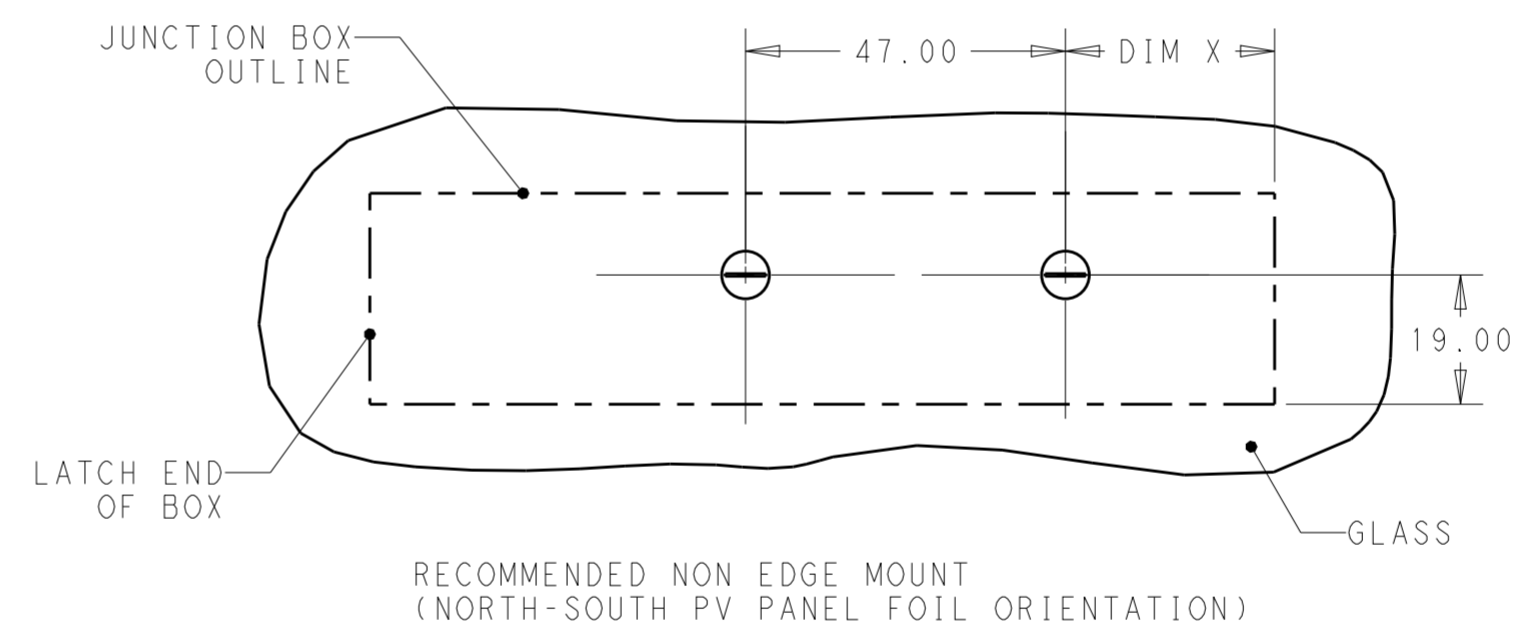
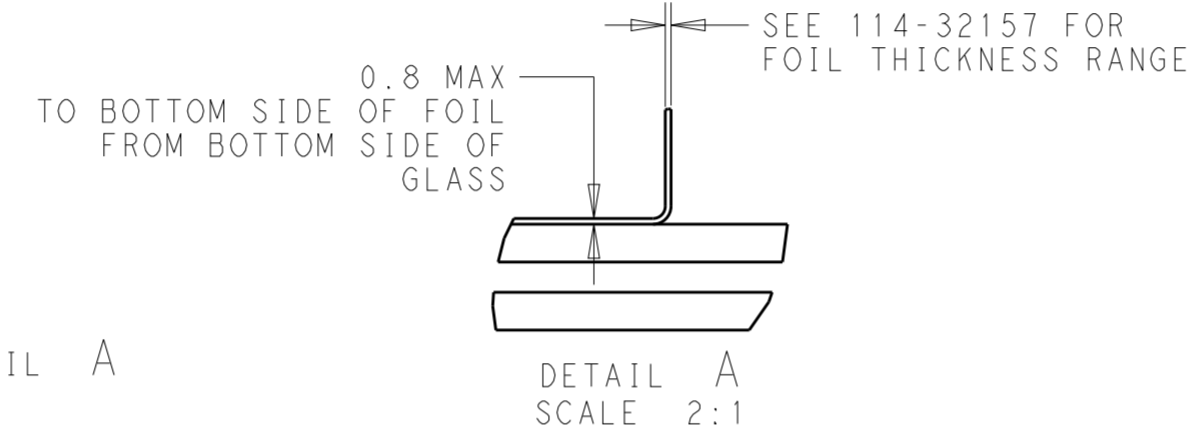
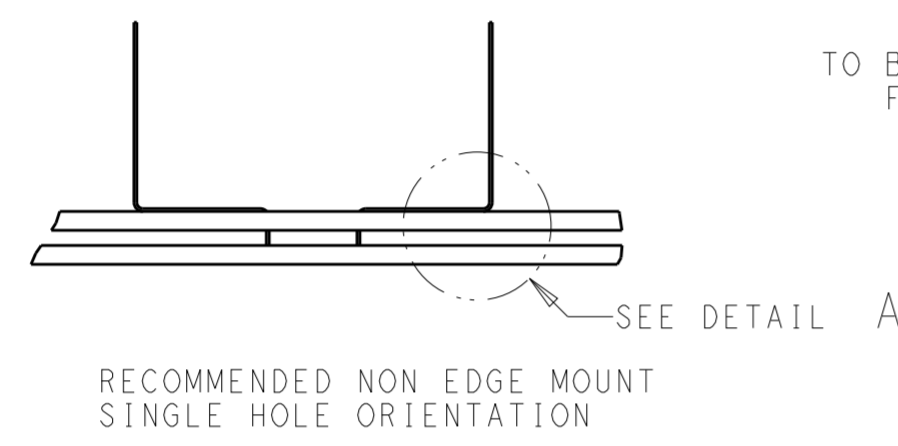
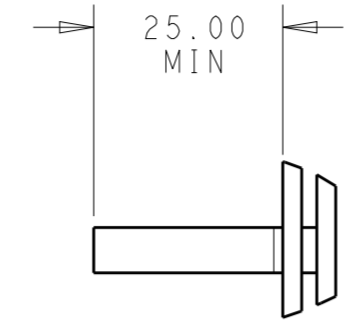
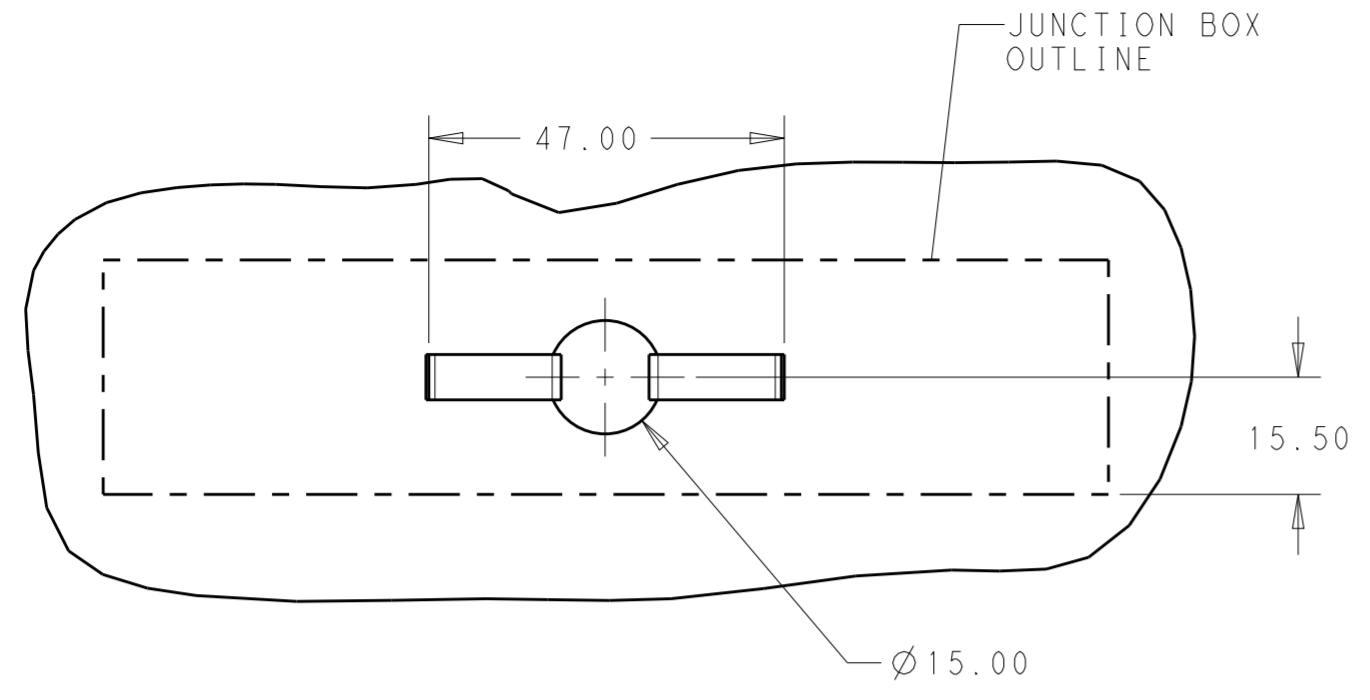

THIS DRAWING IS A CONTROLLED DOCUMENT.		DWN RAVLS 13AUG2016	TE Connectivity	
DIMENSIONS: mm		CHK GINGRICH CHUCK 13AUG2016		
TOLERANCES UNLESS OTHERWISE SPECIFIED:		APVD GINGRICH CHUCK 13AUG2016	NAME PV EDGE ASSEMBLY, WITHOUT FLAP, OMEGA CLIP	
0 PLC ±0.50		PRODUCT SPEC 108-32122	RESTRICTED TO	
1 PLC ±0.25		APPLICATION SPEC 114-32157	SIZE A2	CAGE CODE C-2306317
2 PLC ±0.13		WEIGHT -	SCALE 5:1	SHEET 4 OF 4
3 PLC ±		CUSTOMER DRAWING	REV A	
4 PLC ±				
ANGLES ±				
FINISH -				

## X-ON Electronics

Largest Supplier of Electrical and Electronic Components

*Click to view similar products for [Adafruit Accessories](#) category:*

*Click to view products by [Adafruit](#) manufacturer:*

Other Similar products are found below :

[3015](#) [3209](#) [2998](#) [3561](#) [2974](#) [3182](#) [3290](#) [2755](#) [3560](#) [3562](#) [2503](#) [3548](#) [3011](#) [3597](#) [3048](#) [2776](#) [3299](#) [2973](#) [2922](#) [2958](#) [2860](#) [2836](#) [3558](#)  
[2686](#) [2968](#) [2972](#) [2969](#) [2871](#) [2851](#) [2873](#) [2895](#) [3610](#) [2939](#) [2698](#) [3568](#) [2869](#) [2866](#) [3551](#) [2858](#) [2855](#) [3590](#) [3447](#) [3581](#) [3353](#) [2744](#) [3585](#)  
[3584](#) [3552](#) [3484](#) [2865](#)