

N-Channel Enhancement Mode MOSFET

TDM31056A

DESCRIPTION

The TDM31056A uses advanced trench technology to provide excellent RDS(ON) and low gate charge. This device is suitable for use as a load switch or in PWM applications.

GENERAL FEATURES

- RDS(ON) < 16mΩ @ VGS=10V
RDS(ON) < 22.5mΩ @ VGS=4.5V
- Extremely low switching loss
- Excellent stability and uniformity
- Lead free product is available
- DFN5X6-8 Package

Application

- High Frequency Switching
- Synchronous Rectification

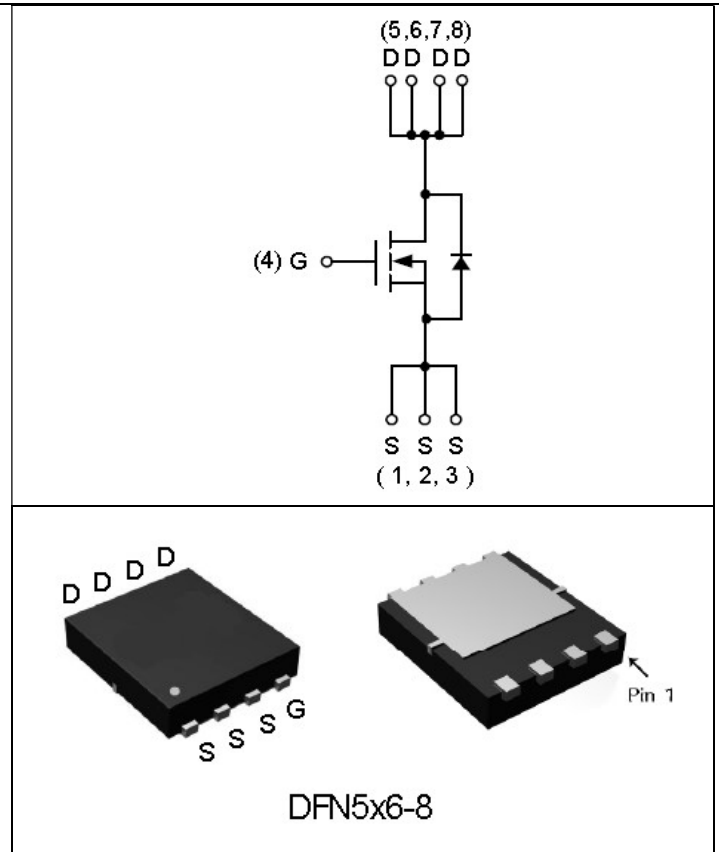

ABSOLUTE MAXIMUM RATINGS(Tc=25°C unless otherwise noted)

Parameter	Symbol	Limit	Unit
Drain-Source Voltage	V _{DS}	100	V
Gate-Source Voltage	V _{GS}	±20	V
Drain Current @ Continuous (Note 1)	I _D (T _c =25°C)	40	A
	I _D (T _c =100°C)	27	A
Pulsed Drain Current (Note 2)	I _{DM}	160	A
Maximum Power Dissipation (Note 3)	P _D (T _c =25°C)	50	W
Thermal Resistance, Junction-to-Case (Note 4)	R _{θJC}	2.1	°C/W
Thermal Resistance, Junction-to-Ambient (Note 4, Note 5)	R _{θJA}	55	°C/W
Avalanche Current, Single pulse (Note 2, Note 6)	I _{AS} (L=0.5mH)	6	A
Avalanche Energy, Single pulse (Note 2, Note 6)	E _{AS} (L=0.5mH)	32	mJ
Maximum Operating Junction Temperature	T _J	150	°C
Storage Temperature Range	T _{STG}	-55 To 150	°C

N-Channel Enhancement Mode MOSFET

TDM31056A

ELECTRICAL CHARACTERISTICS (T_c=25°C unless otherwise noted)

Parameter	Symbol	Condition	Min	Typ	Max	Unit
OFF CHARACTERISTICS						
Drain-Source Breakdown Voltage	BV _{DSS}	V _{GS} =0V I _D =250μA	100	-	-	V
Zero Gate Voltage Drain Current	I _{DSS}	V _{DS} =80V, V _{GS} =0V	-	-	1	μA
Gate-Body Leakage Current	I _{GSS}	V _{GS} =±20V, V _{DS} =0V	-	-	±100	nA
ON CHARACTERISTICS						
Gate Threshold Voltage	V _{GS(th)}	V _{DS} =V _{GS} , I _D =250μA	1.2	1.8	2.5	V
Drain-Source On-State Resistance	R _{DS(ON)}	V _{GS} =10V, I _D =20A	-	14.3	16	mΩ
	R _{DS(ON)}	V _{GS} =4.5V, I _D =10A	-	18.8	22.5	mΩ
Gate Resistance	R _G	V _{DS} =0V, V _{GS} =0V, F=1.0MHz	-	1.5	-	Ω
DYNAMIC CHARACTERISTICS (Note7)						
Input Capacitance	C _{iss}	V _{DS} =25V, V _{GS} =0V, F=1.0MHz	-	1130	-	PF
Output Capacitance	C _{oss}		-	496	-	PF
Reverse Transfer Capacitance	C _{rss}		-	60	-	PF
SWITCHING CHARACTERISTICS (Note 7)						
Turn-on Delay Time	t _{d(on)}	V _{DS} =50V, V _{GS} =10V, R _G =3.3Ω I _D =40A	-	46	-	nS
Turn-on Rise Time	t _r		-	55	-	nS
Turn-Off Delay Time	t _{d(off)}		-	249	-	nS
Turn-Off Fall Time	t _f		-	105	-	nS
Total Gate Charge	Q _g	V _{DS} =50V, I _D =40A, V _{GS} =10V	-	30	-	nC
Gate-Source Charge	Q _{gs}		-	6	-	nC
Gate-Drain Charge	Q _{gd}		-	8.2	-	nC
DRAIN-SOURCE DIODE CHARACTERISTICS						
Continuous Source Current	I _S		-	40	-	A
Diode Forward Voltage	V _{SD}	V _{GS} =0V, I _S =20A	-	0.8	1.0	V
Reverse Recovery Time	T _{rr}	I _F =20A, dI/dt=100A/μs	-	70	-	nS
Reverse Recovery Charge	Q _{rr}		-	224	-	nC

NOTES:

- The maximum current rating is package limited.
- Single pulse width limited by junction temperature T_{J(MAX)}=150°C.
- The power dissipation PD is based on T_{J(MAX)}=150°C, using junction-to-case thermal resistance, and is more useful in setting the upper dissipation limit for cases where additional heatsinking is used.
- The value of R_{θJC} is measured in a still air environment with T_A =25°C and the maximum allowed junction temperature of 150°C. The value in any given application depends on the user's specific board design.
- The R_{θJA} is the sum of the thermal impedance from junction to case R_{θJC} and case to ambient.
- The EAS data shows Max. rating. The test condition is V_{DS}=50V, V_{GS}=10V, L=0.5mH
- Guaranteed by design, not subject to production testing

Typical Operating Characteristics

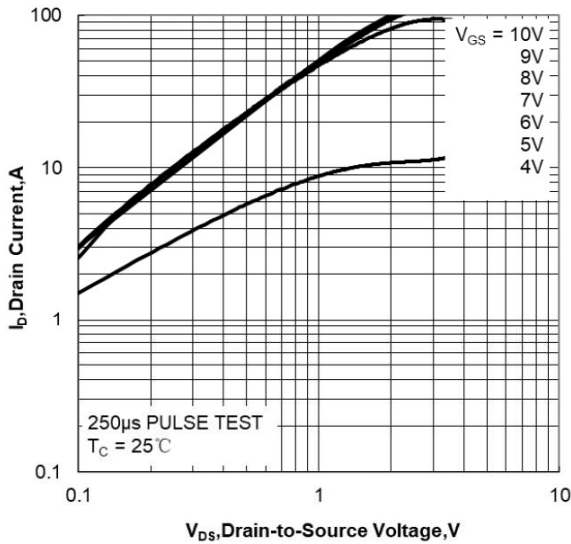

Figure 1. Output Characteristics

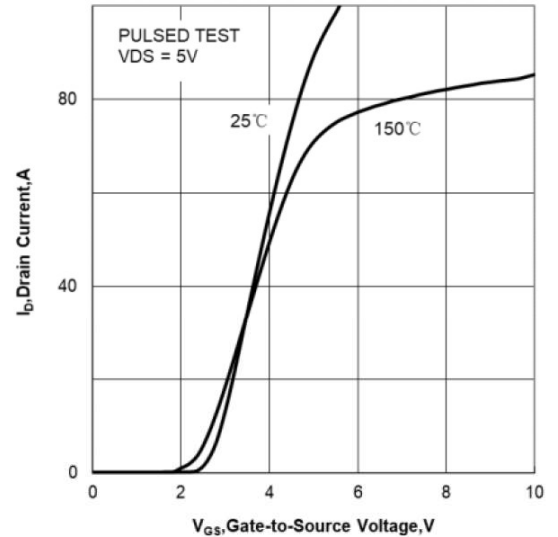

Figure 2. Transfer Characteristics

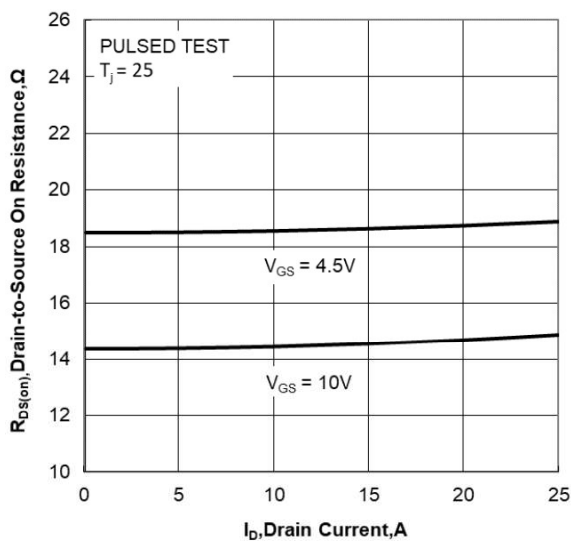

Figure 3. Drain-to-Source On Resistance vs Drain Current

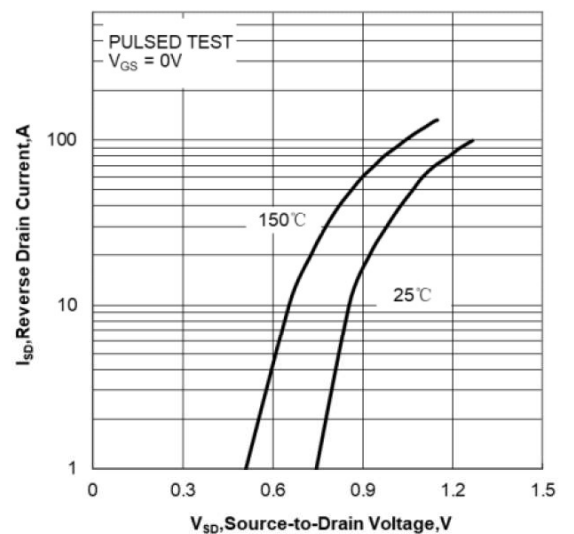

Figure 4. Body Diode Forward Voltage vs Source Current and Temperature

Typical Operating Characteristics (Cont.)

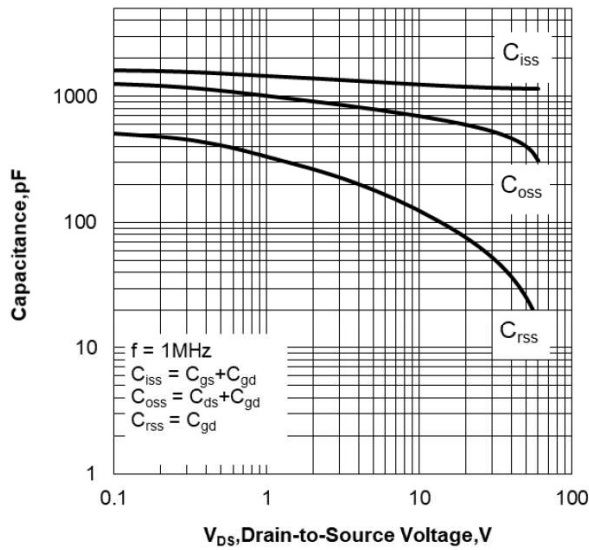

Figure 5. Capacitance Characteristics

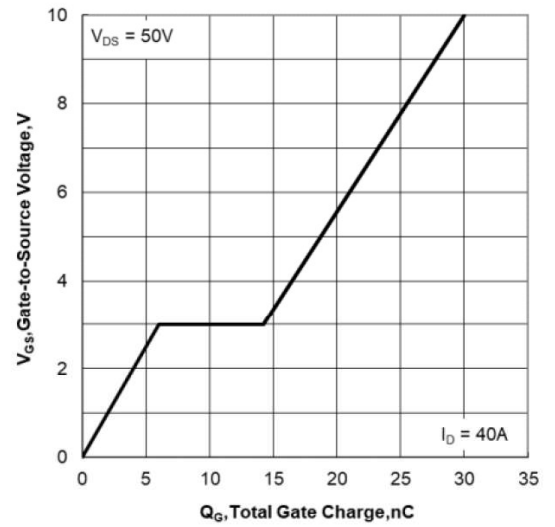

Figure 6. Gate Charge Characteristics

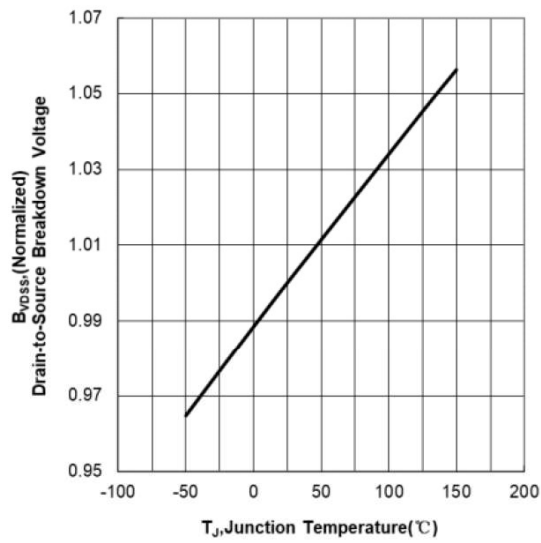

Figure 7. Normalized Breakdown Voltage vs Junction Temperature

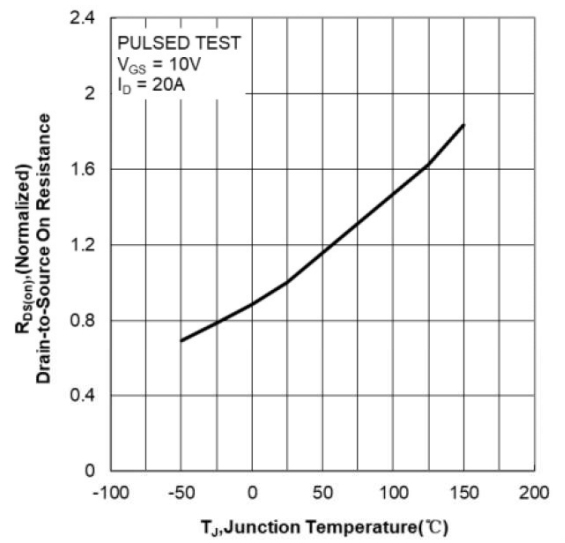

Figure 8. Normalized On Resistance vs Junction Temperature

Typical Operating Characteristics (Cont.)

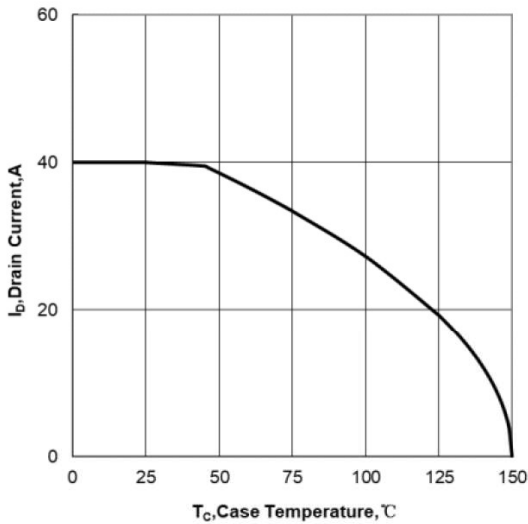

Figure 9. Maximum Continuous Drain Current vs Case Temperature

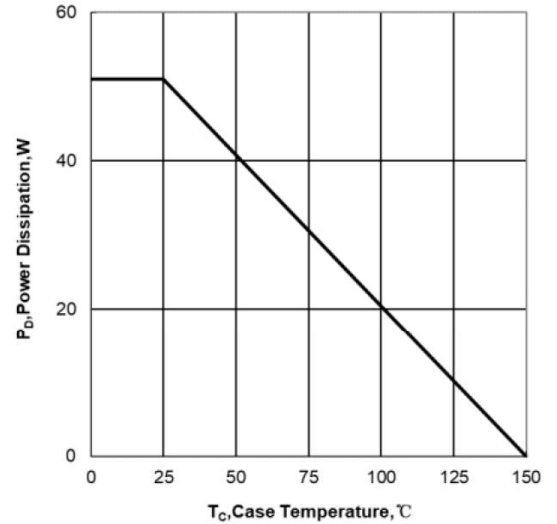

Figure 10. Maximum Power Dissipation vs Case Temperature

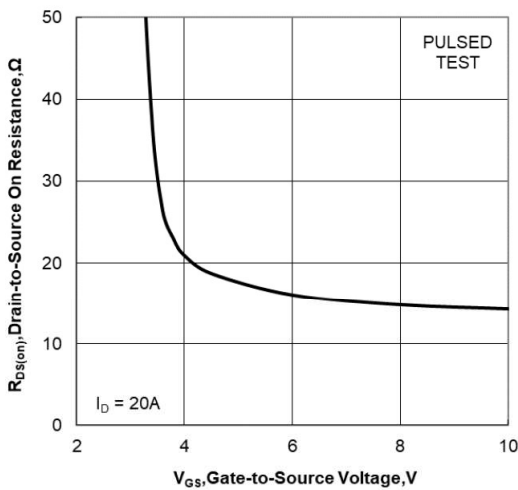

Figure 11. Drain-to-Source On Resistance vs Gate Voltage and Drain Current

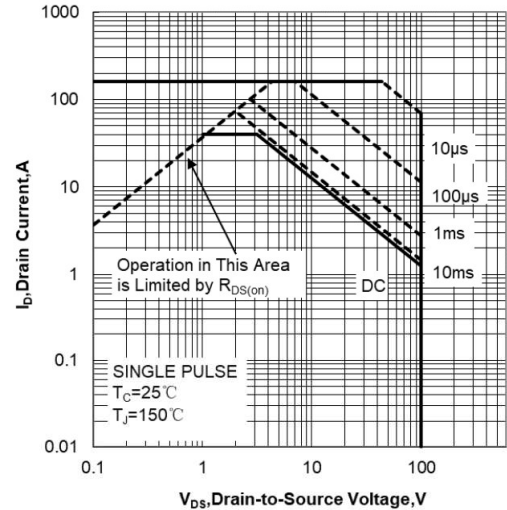

Figure 12. Maximum Safe Operating Area

Typical Operating Characteristics (Cont.)

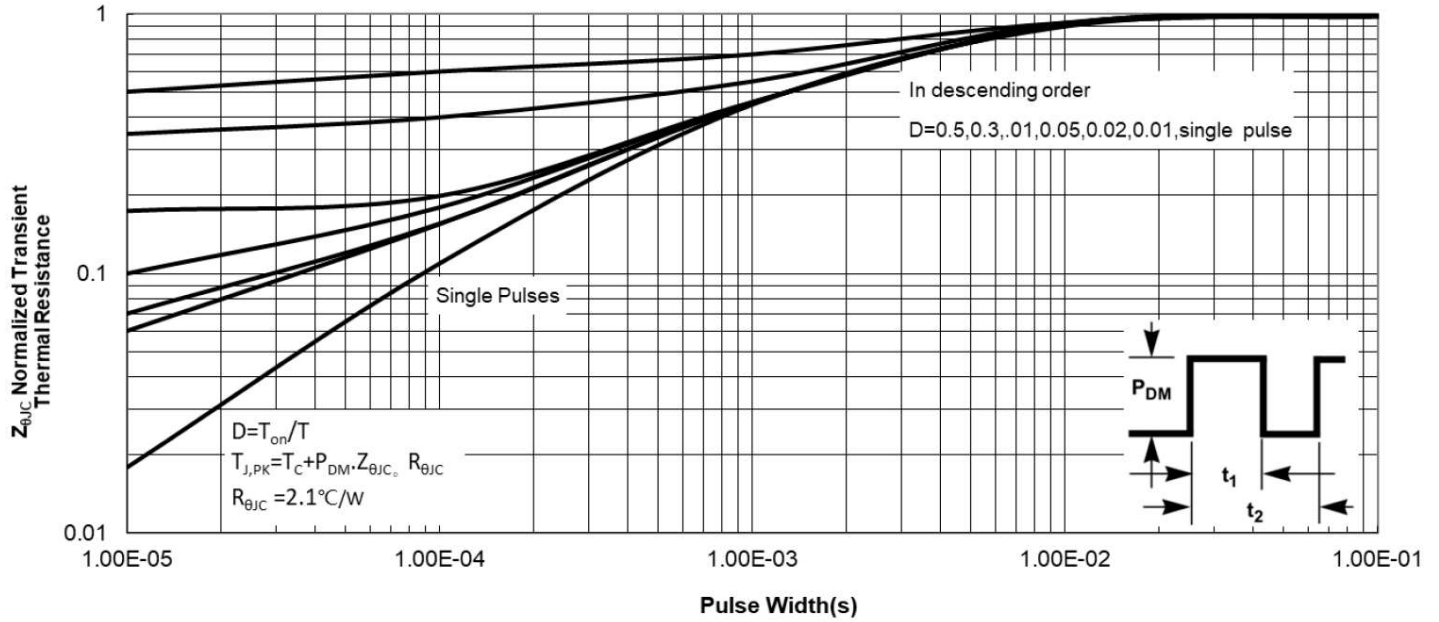
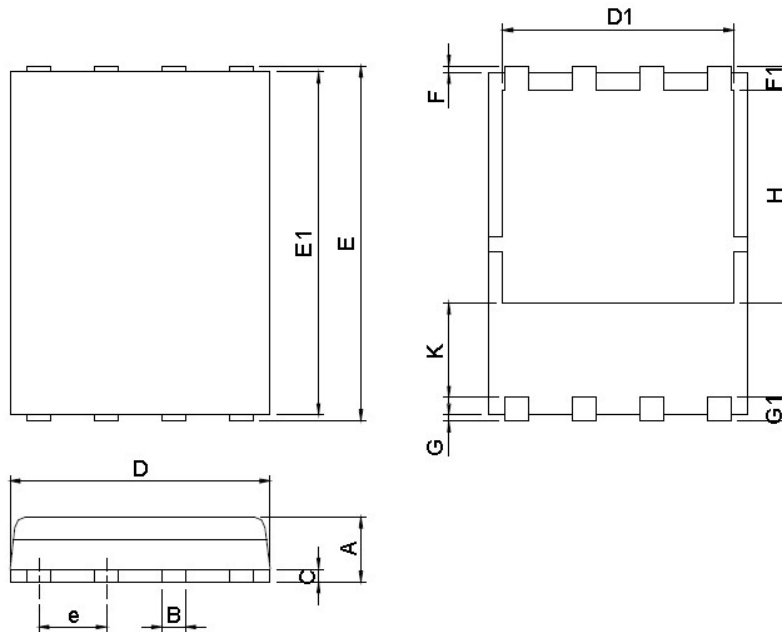

Figure 13. Maximum Effective Transient Thermal Impedance, Junction-to-Case

Package Information

DFN5*6-8 Package



DIMENSIONS	DFN5x6-8			
	MILLIMETERS		INCHES	
	MIN.	MAX.	MIN.	MAX.
A	0.90	1.20	0.035	0.047
B	0.3	0.51	0.012	0.020
C	0.19	0.25	0.007	0.010
D	4.80	5.30	0.189	0.209
D1	4.00	4.40	0.157	0.173
E	5.90	6.20	0.232	0.244
E1	5.50	5.80	0.217	0.228
e	1.27 BSC		0.050 BSC	
F	0.05	0.30	0.002	0.012
F1	0.35	0.75	0.014	0.030
G	0.05	0.30	0.002	0.012
G1	0.35	0.75	0.014	0.030
H	3.34	3.9	0.131	0.154
K	0.762	-	0.03	-

RECOMMENDED LAND PATTERN

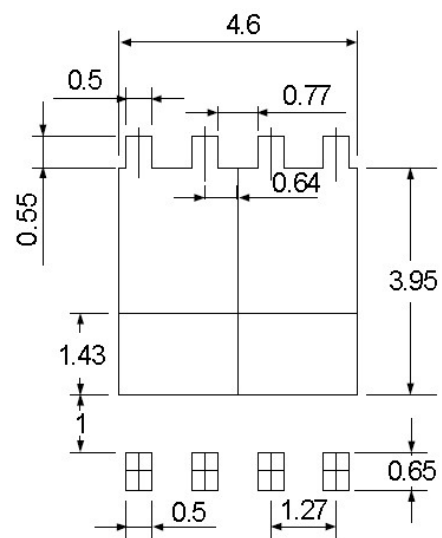

UNIT: mm

Note : 1.Dimension D, D1,D2 and E1 do not include mold flash or protrusions. Mold flash or protrusions shall not exceed 10 mil.

Design Notes

X-ON Electronics

Largest Supplier of Electrical and Electronic Components

Click to view similar products for [MOSFET](#) category:

Click to view products by [Techcode](#) manufacturer:

Other Similar products are found below :

[IRFD120](#) [JANTX2N5237](#) [2SK2267\(Q\)](#) [BUK455-60A/B](#) [TK100A10N1,S4X\(S](#) [MIC4420CM-TR](#) [VN1206L](#) [NDP4060](#) [SI4482DY](#)
[IRS2092STRPBF-EL](#) [IPS70R2K0CEAKMA1](#) [TK31J60W5,S1VQ\(O](#) [TK31J60W,S1VQ\(O](#) [TK16J60W,S1VQ\(O](#) [2SK2614\(TE16L1,Q\)](#)
[DMN1017UCP3-7](#) [EFC2J004NUZTDG](#) [P85W28HP2F-7071](#) [DMN1053UCP4-7](#) [NTE2384](#) [DMC2700UDMQ-7](#) [DMN2080UCB4-7](#)
[DMN61D9UWQ-13](#) [US6M2GTR](#) [DMN31D5UDJ-7](#) [DMP22D4UFO-7B](#) [IPS60R3K4CEAKMA1](#) [DMN1006UCA6-7](#) [DMN16M9UCA6-7](#)
[STF5N65M6](#) [IRF40H233XTMA1](#) [STU5N65M6](#) [DMN6022SSD-13](#) [DMN13M9UCA6-7](#) [DMTH10H4M6SPS-13](#) [IPS60R360PFD7SAKMA1](#)
[DMN2990UFB-7B](#) [SSM3K35CT,L3F](#) [IPLK60R1K0PFD7ATMA1](#) [2N7002W-G](#) [MCAC30N06Y-TP](#) [IPWS65R035CFD7AXKSA1](#)
[MCQ7328-TP](#) [SSM3J143TU,LXHF](#) [DMN12M3UCA6-7](#) [PJMF280N65E1_T0_00201](#) [PJMF380N65E1_T0_00201](#)
[PJMF280N60E1_T0_00201](#) [PJMF600N65E1_T0_00201](#) [PJMF900N65E1_T0_00201](#)