

GENERAL DESCRIPTION

These devices consist of two independent, high gain, internally frequency-compensated operational amplifiers designed operate from a single supply over a wide range of voltages. Operation from split supplies also is possible if the difference between the two supplies is 3V to 36V, and V_{CC} is at least 1.5V more positive than the input common-mode voltage, the low supply-current drain is independent of the magnitude of the power supply voltage.

Features

- One internally compensated OP amps
- Wide power supply range: 3V to 36V
- Large output voltage swing: 0V to $V_{CC}-1.5V$
- Low input bias current
- Low input offset voltage and offset current
- Internally frequency compensated for unity gain
- Short Circuit Protected Outputs
- Input common-mode voltage range includes ground
- SOT-23-5L package

Applications

- Multivibrators
- Oscillators
- Switching Telephone
- Portable Systems

Pin Assignments

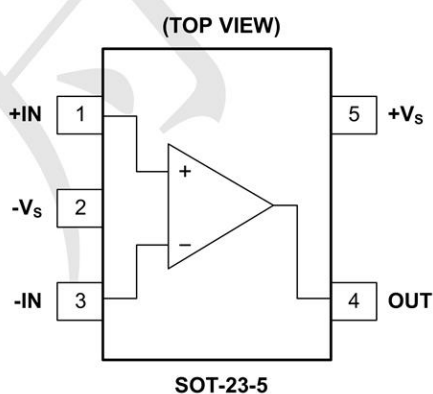

Absolute Maximum Ratings

Characteristics	Symbol	Rating	Unit
Power Supply Voltage (Single Supply)	V_{CC}	40	V
Power Supply Voltage (Split Supplies)	V_{CC}, V_{SS}	± 20	V
Input Differential Voltage Range	V_{IDR}	± 20	V
Input Common Mode Voltage Range	V_{ICR}	-0.3 to V_{CC}	V
Output Short Circuit Duration	T_{SC}	Continuous	
Power Dissipation	PD	500	mW
Storage Temperature Range	T_{ST}	-55 to +165	°C
Operating Junction Temperature	T_{OPJ}	-40 to +125	°C
Junction Temperature Range	T_J	150	°C
Thermal Resistance from Junction to case	θ_{JC}	110	°C/W
Thermal Resistance from Junction to ambient	θ_{JA}	250	°C/W

Electrical Characteristics

($V_{CC} = 5V$, $T_A = 25^\circ C$, unless otherwise specified)

Characteristics	Symbol	Conditions (Note1)	Min	Typ	Max	Units
Input offset voltage(Note2)	V_{IO}	$V_{CC}=5V$ to Max, $V_{IC}=V_{ICR}$ min, $V_O=1.4V$	1	5	11	mV
Average temperature coefficient of input offset voltage	αV_{IO}		-	7	-	$\mu V/^\circ C$
Input offset current	I_{IO}	$V_O=1.4V$	-	2	50	nA
Average temperature coefficient of input offset current	αI_{IO}		-	10	-	$pA/^\circ C$
Input bias current	I_{IB}	I_{IN+} or I_{IN-}	-	-20	-250	nA
Common-mode input voltage range	V_{ICR}	$V_{CC}=5V$ to Max	0 to $V_{CC}-1.5$	-	-	V
High-level output voltage	V_{OH}	$V_{CC}=\text{Max}$, $R_L=2K\Omega$	26	-	-	V
		$V_{CC}=\text{Max}$, $R_L \geq 10K\Omega$	27	28	-	
Low-level output voltage	V_{OL}	$R_L \geq 10K\Omega$	-	5	20	mV
Large-signal differential voltage amplification	A_{VD}	$V_{CC}=15V$, $V_O=1V$ to $11V$, $R_L \geq 2K\Omega$	25	100	-	V/mV
Common-mode rejection ratio	CMRR	$V_{CC}=5V$ to Max, $V_{IC}=V_{ICR}$ min.	65	80	-	dB
Supply voltage rejection ratio ($\Delta V_{CC}/\Delta V_{IO}$)	K_{SVR}	$V_{CC}=5V$ to Max	65	100	-	dB
Crosstalk attenuation	V_{OUT}	$F=1KHz$ to $20KHz$	-	120	-	dB
Output current	I_O	$V_{CC}=15V$, $V_{ID}=1V$, $V_O=0V$	-20	-30	-	mA
		$V_{CC}=15V$, $V_{ID}=-1V$, $V_O=2V$	10	20	-	
		$V_{ID}=-1V$, $V_O=200mV$	12	30	-	μA
Short-circuit output current	I_{OS}	$V_{CC}=15V$, $V_O=0V$	-	40	-	mA
Supply current	I_{CC}	$V_O=2.5V$, No Load	-	0.7	1.2	mA
		$V_{CC}=\text{Max}$, $V_O=0.5V_{CC}$, No Load	-	1	2	

APPLICATION CIRCUIT

Voltage Follower

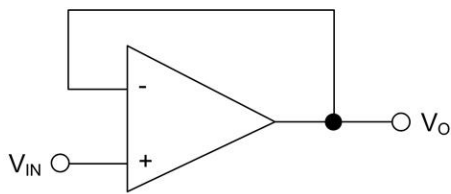

Non Inverting DC Amplifier

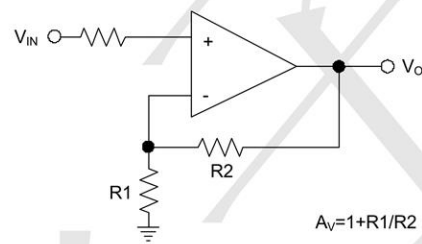

DC Summing Amplifier

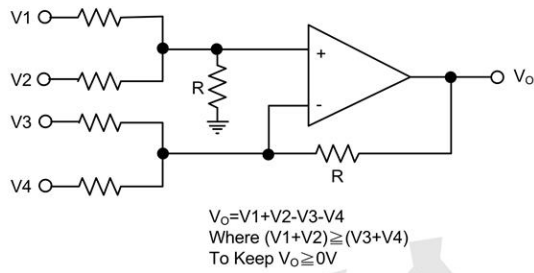

Square-wave Oscillator

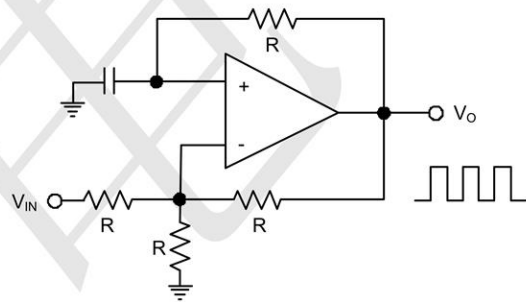

DC Coupled Low-Pass RC Active Filter

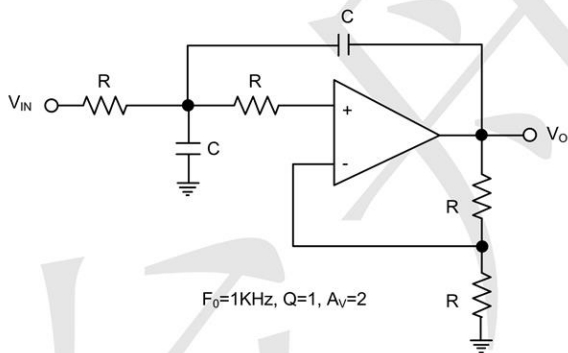

Pulse Generator

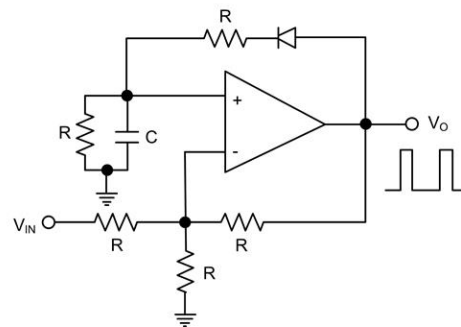

Typical Performance Characteristics

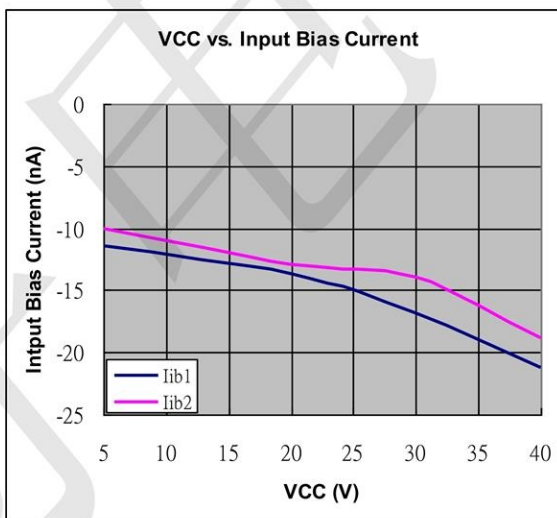
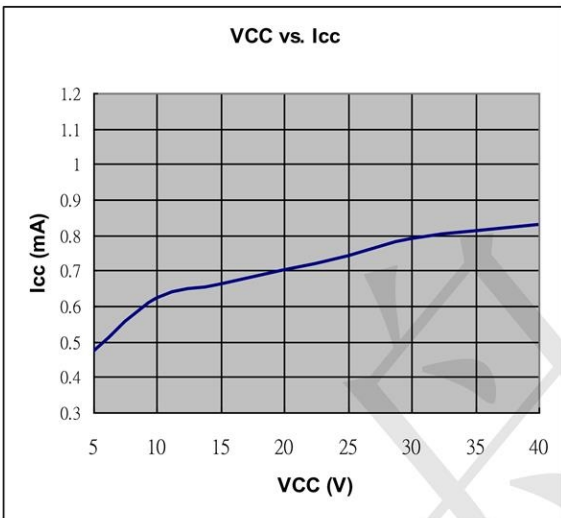
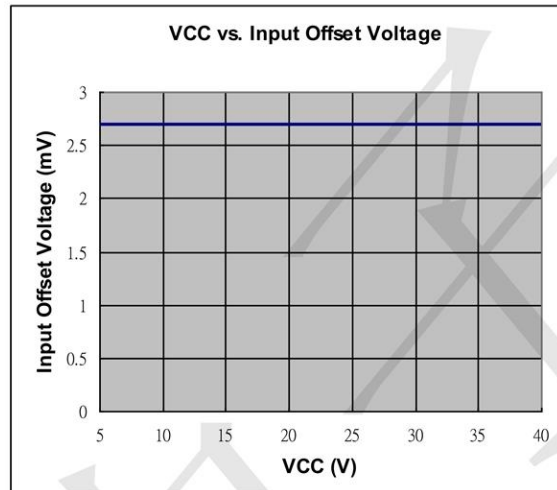
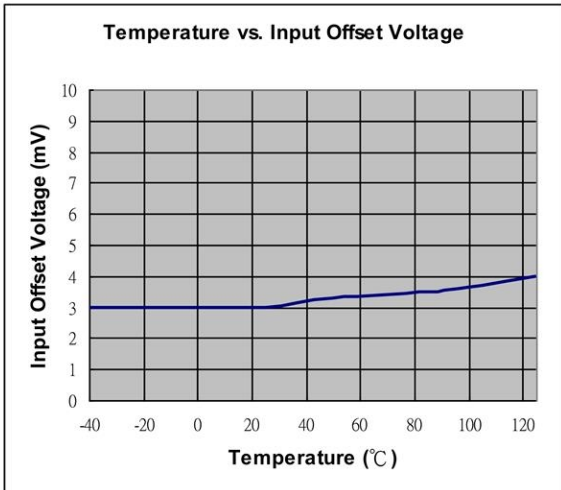

Package Information

SOT-23-5

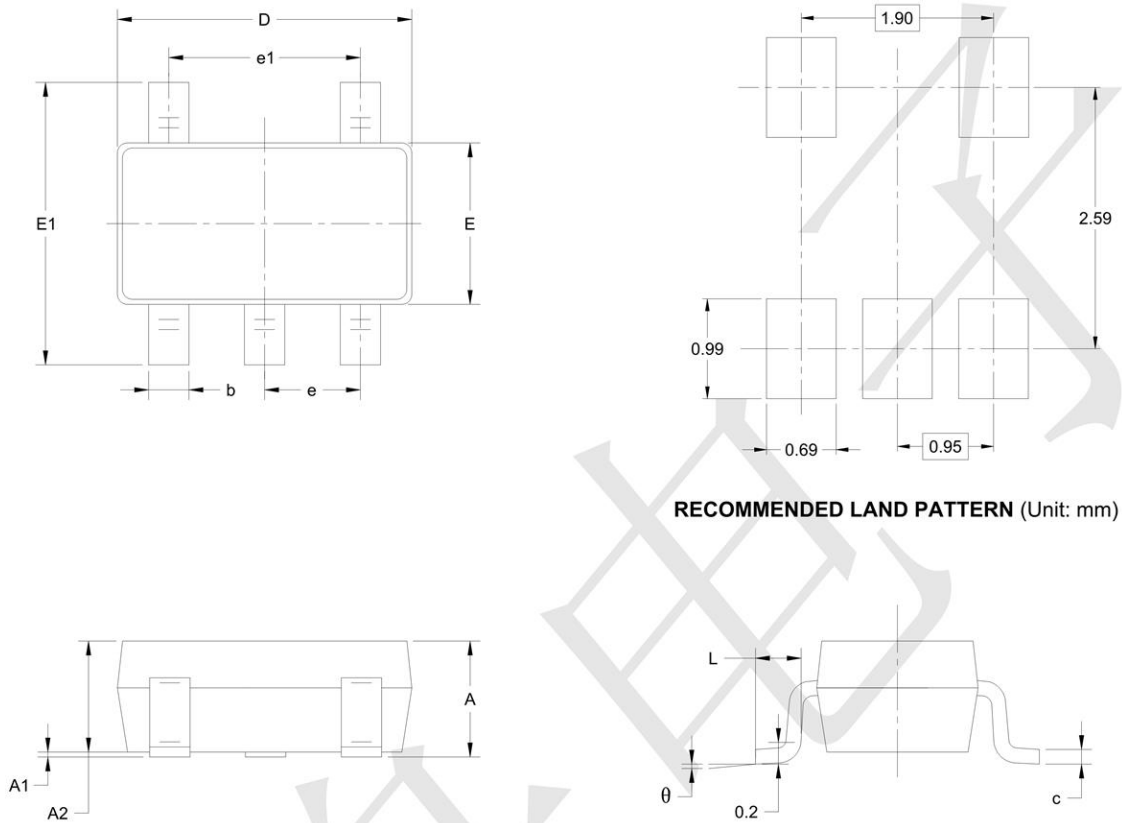

Symbol	Dimensions In Millimeters		Dimensions In Inches	
	MIN	MAX	MIN	MAX
A	1.050	1.250	0.041	0.049
A1	0.000	0.100	0.000	0.004
A2	1.050	1.150	0.041	0.045
b	0.300	0.500	0.012	0.020
c	0.100	0.200	0.004	0.008
D	2.820	3.020	0.111	0.119
E	1.500	1.700	0.059	0.067
E1	2.650	2.950	0.104	0.116
e	0.950 BSC		0.037 BSC	
e1	1.900 BSC		0.075 BSC	
L	0.300	0.600	0.012	0.024
θ	0°	8°	0°	8°

X-ON Electronics

Largest Supplier of Electrical and Electronic Components

Click to view similar products for [Operational Amplifiers - Op Amps](#) category:

Click to view products by [TECH PUBLIC](#) manufacturer:

Other Similar products are found below :

[430227FB](#) [AZV831KTR-G1](#) [UPC451G2-A](#) [UPC824G2-A](#) [LT1678IS8](#) [042225DB](#) [058184EB](#) [UPC822G2-A](#) [UPC258G2-A](#)
[NCS5651MNTXG](#) [NCV33202DMR2G](#) [NJM324E](#) [NTE925](#) [5962-9080901MCA*](#) [AP4310AUMTR-AG1](#) [HA1630D02MMEL-E](#)
[HA1630S01LPEL-E](#) [SCY33178DR2G](#) [NJU77806F3-TE1](#) [NCV5652MUTWG](#) [NCV20034DR2G](#) [LM2902EDR2G](#) [NTE778S](#) [NTE871](#)
[NTE924](#) [NTE937](#) [MCP6V16UT-E/OT](#) [MCP6V17T-E/MS](#) [MCP6V19T-E/ST](#) [SCY6358ADR2G](#) [LTC2065IUD#PBF](#) [NCS20282FCTTAG](#)
[LM4565FVT-GE2](#) [EL5420CRZ-T7A](#) [TSV791IYLT](#) [TSV772IQ2T](#) [TLV2772QPWR](#) [NJM2100M-TE1](#) [NJM4556AM-TE1](#) [MCP6487-E/SN](#)
[MCP6487-E/MS](#) [AS324MTR-E1](#) [AS358MMTR-G1](#) [MCP6232T-EMNY](#) [MCP662-E/MF](#) [TLC081AIP](#) [TLC082AIP](#) [TLE2074ACDW](#)
[TLV07IDR](#) [TLV2170IDGKT](#)