

### GENERAL FEATURES

$V_{DS}$	$R_{DS(ON)} MAX$	$I_D MAX$
-250V	4.2Ω@-10V	-0.45A
	4.5mΩ@-4.5V	

### Application

- Load/Power Switching
- Interfacing Switching
- Logic Level Shift

### Package and Pin Configuration

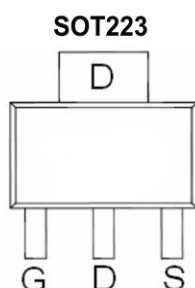

### Circuit diagram

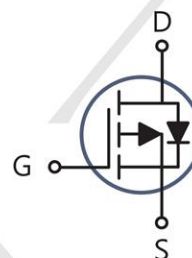

### Marking:

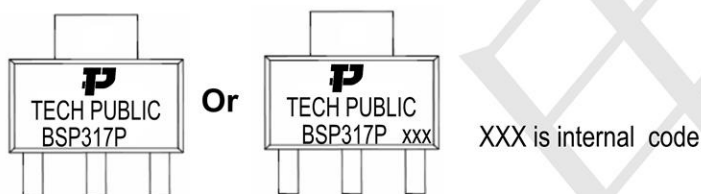

### ABSOLUTE MAXIMUM RATINGS ( $T_C=25^{\circ}C$ unless otherwise noted)

Parameter	Symbol	Limit	Units	
Drain-Source Voltage	$V_{DS}$	-250	V	
Gate-Source Voltage	$V_{GS}$	±20	V	
Drain Current-Continuous (Note 2)	$I_D$	$T_A=25^{\circ}C$	-0.45	A
		$T_A=70^{\circ}C$	-0.35	A
- Pulsed (Note 1、Note 2)	$I_{DM}$	-1.72	A	
Single Pulse Avalanche Energy (Note 3)	EAS	12	mJ	
Maximum Power Dissipation	$T_A=25^{\circ}C$	1.8	W	
Operating Junction and Storage Temperature Range	$T_J, T_{STG}$	-55 to 150	$^{\circ}C$	

### THERMAL CHARACTERISTICS

Thermal Resistance, Junction-to-Ambient	$R_{\theta JA}$	160	$^{\circ}C/W$
---	-----------------	-----	---------------

**ELECTRICAL CHARACTERISTICS** ( $T_c=25^\circ\text{C}$  unless otherwise noted)

Parameter	Symbol	Test Conditions	Min	Typ	Max	Units
-----------	--------	-----------------	-----	-----	-----	-------

**OFF CHARACTERISTICS**

Drain-Source Breakdown Voltage	$BV_{DSS}$	$V_{GS}=0V, I_D=-250\mu A$	-250			V
Zero Gate Voltage Drain Current	$I_{DSS}$	$V_{DS}=-200V, V_{GS}=0V$			-1	$\mu A$
Gate-Body Leakage Current	$I_{GSS}$	$V_{GS}=\pm 20V, V_{DS}=0V$			$\pm 100$	nA

**ON CHARACTERISTICS**

Gate Threshold Voltage	$V_{GS(th)}$	$V_{DS}=V_{GS}, I_D=-250\mu A$	-1	-1.5	-3	V
Drain-Source On-State Resistance	$R_{DS(ON)}$	$V_{GS}=-10V, I_D=-0.3A$		3.3	4.2	ohm
		$V_{GS}=-4.5V, I_D=-0.2A$		3.4	4.5	ohm
Forward Transconductance	$g_{FS}$	$V_{DS}=10V, I_D=-0.3A$		1.5		S

**DYNAMIC CHARACTERISTICS** (Note 4)

Input Capacitance	$C_{iss}$	$V_{DS}=-100V, V_{GS}=0V$ $f=1.0MHz$		500		pF
Output Capacitance	$C_{oss}$			36.5		pF
Reverse Transfer Capacitance	$C_{rss}$			19.2		pF
Total Gate Charge	$Q_g$	$V_{DS}=-100V, I_D=-0.3A, V_{GS}=-10V$		8.9		nC
Gate-Source Charge	$Q_{gs}$	$V_{DS}=-100V, I_D=-0.3A,$ $V_{GS}=-10V$		1.5		nC
Gate-Drain Charge	$Q_{gd}$			1.8		nC

**SWITCHING CHARACTERISTICS** (Note 4)

Turn-On Delay Time	$t_{D(ON)}$	$V_{DD}=-100V$ $I_D=-0.3A$ $V_{GS}=-10V$ $R_{GEN}=6\text{ ohm}$		1.9		ns
Rise Time	$t_r$			1.6		ns
Turn-Off Delay Time	$t_{D(OFF)}$			21.6		ns
Fall Time	$t_f$			10.2		ns

**DRAIN-SOURCE DIODE CHARACTERISTICS AND MAXIMUM RATINGS**

Diode Forward Voltage	$V_{SD}$	$V_{GS}=0V, I_S=-1A$		-0.83	-1.3	V
-----------------------	----------	----------------------	--	-------	------	---

**Typical Electrical and Thermal Characteristics**

**Figure 1. Output Characteristics**

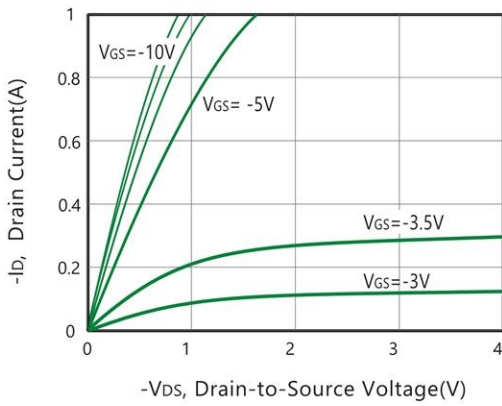

**Figure 2. Body Diode Forward Voltage Variation with Source Current**

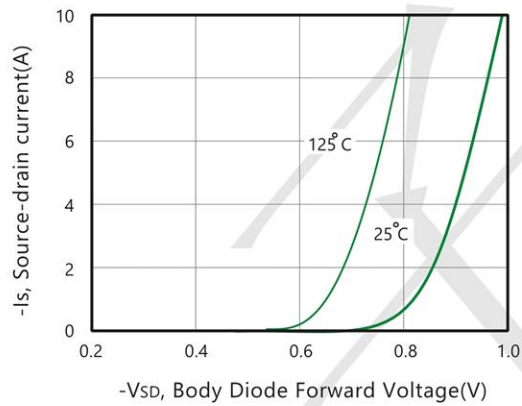

**Figure 3. On-Resistance vs. Gate-Source Voltage**

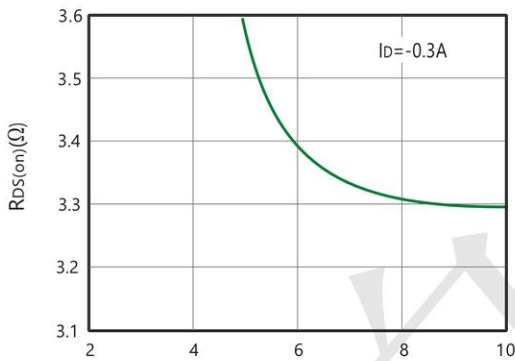

**Figure 4. On-Resistance Variation with Drain Current and Temperature**

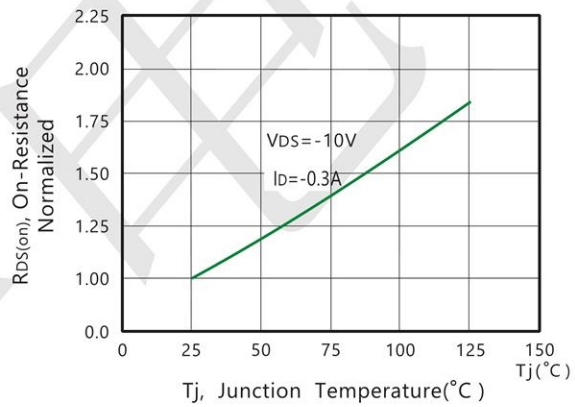

**Figure 5. Gate Threshold Variation with Temperature**

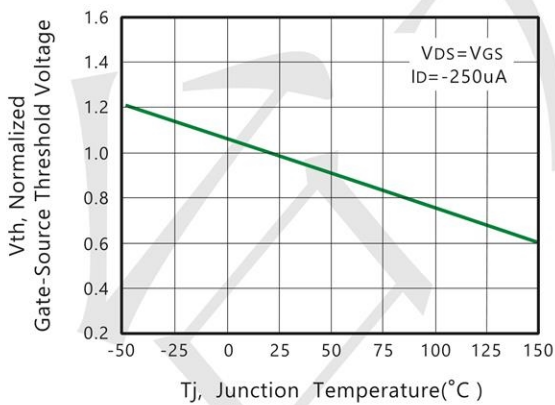

**Figure 6. Gate Charge**

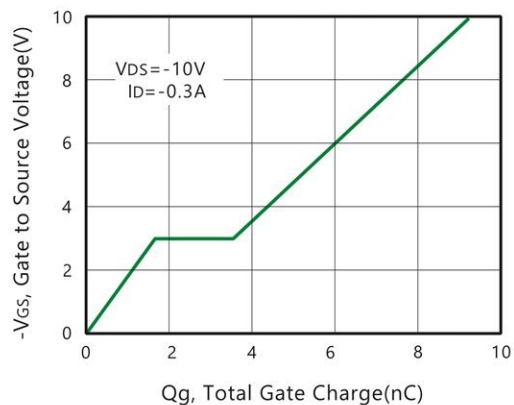

Figure 7. Capacitance

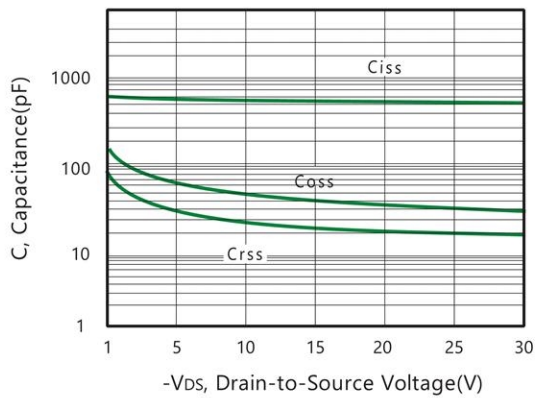

Figure 8. Maximum Safe Operating Area

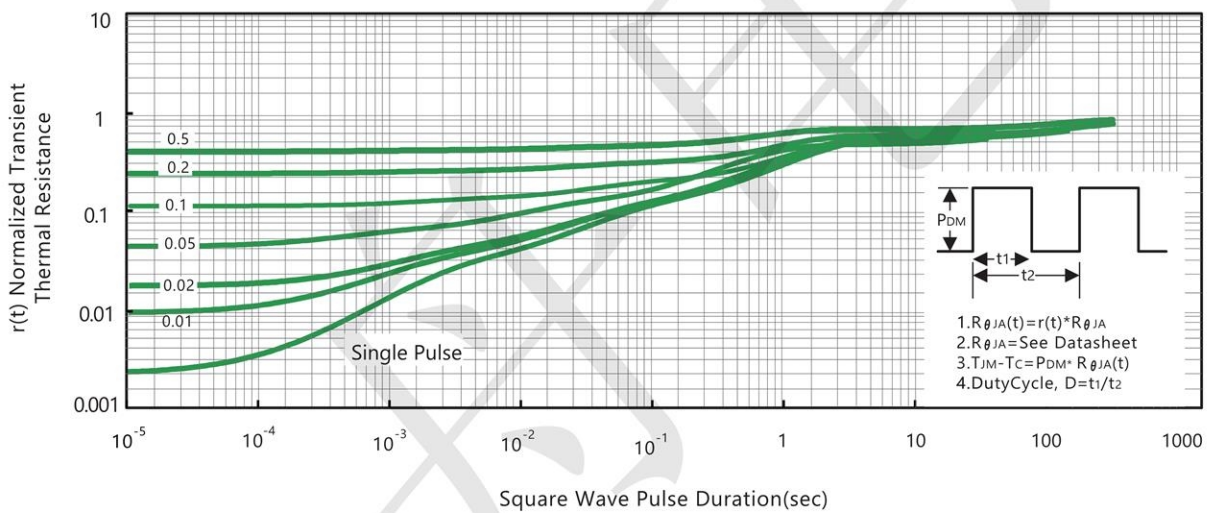
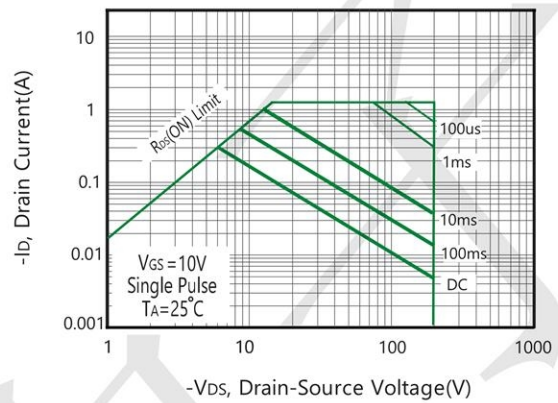

Figure 9. Normalized Thermal Transient Impedance Curve

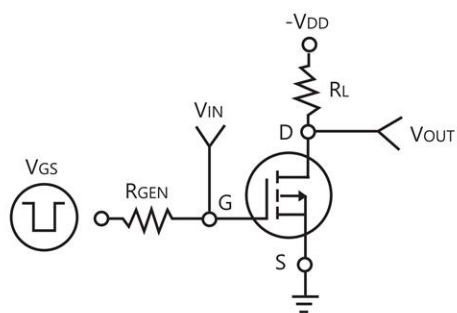

Figure 10a. Switching Test Circuit

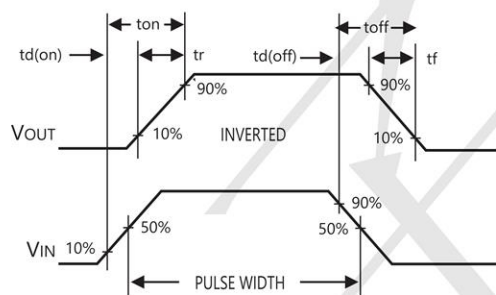
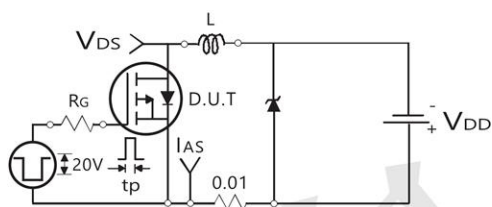
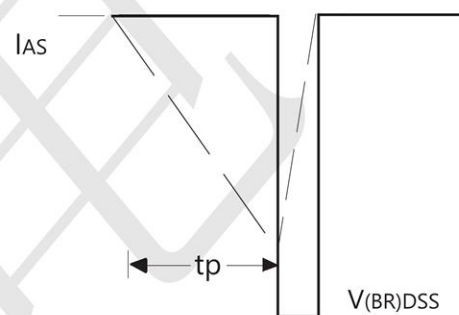

Figure 10b. Switching Waveforms



Unclamped Inductive Test Circuit

Figure 11a.



Unclamped Inductive Waveforms

Figure 11b.

**SOT-223 Package Information**

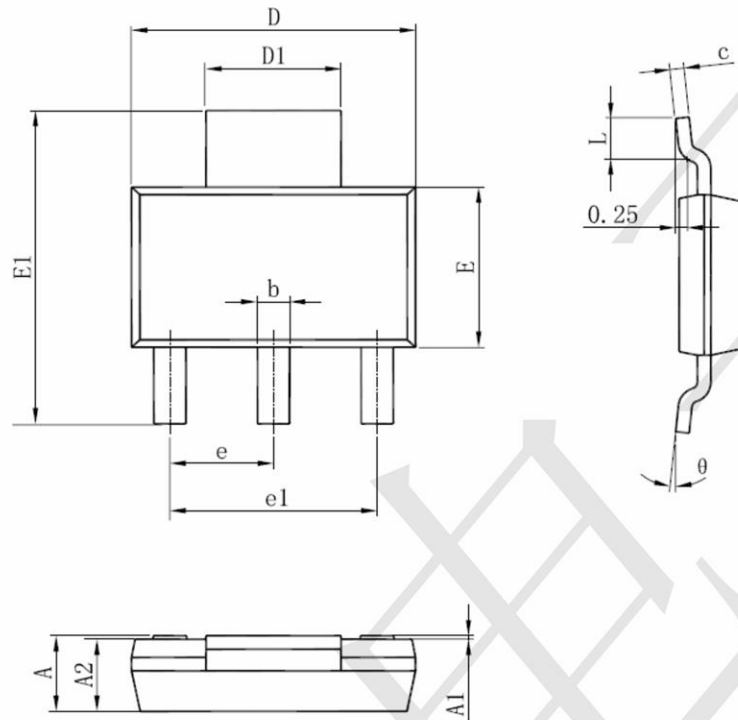

Symbol	Dimensions In Millimeters		Dimensions In Inches	
	Min	Max	Min	Max
A	1.520	1.800	0.060	0.071
A1	0.000	0.100	0.000	0.004
A2	1.500	1.700	0.059	0.067
b	0.660	0.820	0.026	0.032
c	0.250	0.350	0.010	0.014
D	6.200	6.400	0.244	0.252
D1	2.900	3.100	0.114	0.122
E	3.300	3.700	0.130	0.146
E1	6.830	7.070	0.269	0.278
e	2.300(BSC)		0.091(BSC)	
e1	4.500	4.700	0.177	0.185
L	0.900	1.150	0.035	0.045
θ	0°	10°	0°	10°

## X-ON Electronics

Largest Supplier of Electrical and Electronic Components

*Click to view similar products for [MOSFET](#) category:*

*Click to view products by [TECH PUBLIC](#) manufacturer:*

Other Similar products are found below :

[IRFD120](#) [JANTX2N5237](#) [BUK455-60A/B](#) [MIC4420CM-TR](#) [VN1206L](#) [NDP4060](#) [SI4482DY](#) [IPS70R2K0CEAKMA1](#) [SQD23N06-31L-GE3](#)  
[TK16J60W,S1VQ\(O](#) [2SK2614\(TE16L1,Q\)](#) [DMN1017UCP3-7](#) [DMN1053UCP4-7](#) [SQJ469EP-T1-GE3](#) [NTE2384](#) [DMC2700UDMQ-7](#)  
[DMN2080UCB4-7](#) [DMN61D9UWQ-13](#) [US6M2GTR](#) [DMN31D5UDJ-7](#) [DMP22D4UFO-7B](#) [DMN1006UCA6-7](#) [DMN16M9UCA6-7](#)  
[STF5N65M6](#) [IRF40H233XTMA1](#) [STU5N65M6](#) [DMN6022SSD-13](#) [DMN13M9UCA6-7](#) [DMTH10H4M6SPS-13](#) [DMN2990UFB-7B](#)  
[IPB80P04P405ATMA2](#) [2N7002W-G](#) [MCAC30N06Y-TP](#) [MCQ7328-TP](#) [BXP7N65D](#) [BXP4N65F](#) [AOL1454G](#) [WMJ80N60C4](#) [BXP2N20L](#)  
[BXP2N65D](#) [BXT1150N10J](#) [BXT1700P06M](#) [TSM60NB380CP](#) [ROG](#) [RQ7L055BGTCR](#) [DMNH15H110SK3-13](#) [SLF10N65ABV2](#)  
[BSO203SP](#) [BSO211P](#) [IPA60R230P6](#) [IPA60R460CE](#)