

FEATURES

V _{DSS}	R _{DS(on)} Typ	I _D Max
N-Channel 60 V	1.5 Ω @ 10 V	500 mA
	2.0 Ω @ 4.5 V	250 mA
P-Channel -60 V	2.5 Ω @ 10 V	500 mA
	3.0 Ω @ 4.5 V	200 mA

- ESD Protected 2KV HBM

Package and Pin Configuration

SOT563

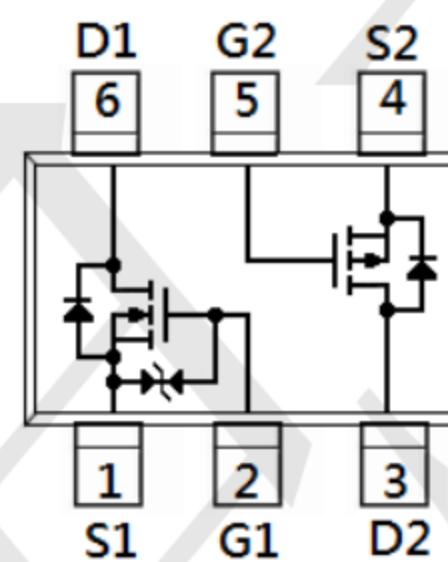
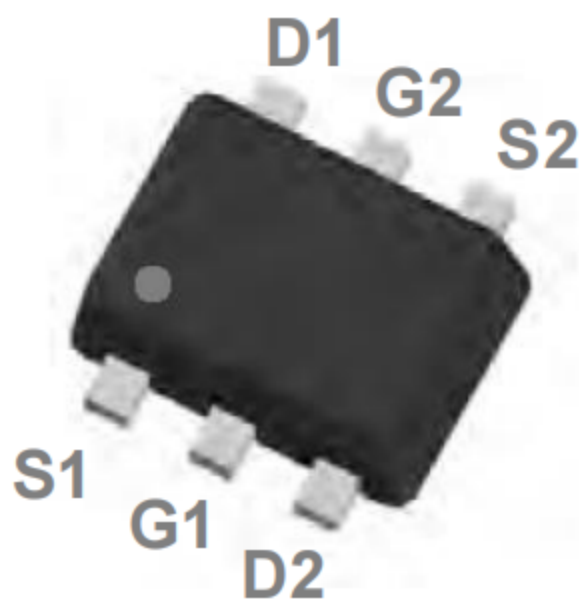

Marking: HUQ

Absolute Maximum Ratings (T_A=25°C unless otherwise noted)

TECH PUBLIC PARAMETER	SYMBOL	N-Ch	P-Ch	UNITS
Drain-Source Voltage	V _{DS}	60	-60	V
Gate-Source Voltage	V _{GS}	±20	±20	V
Continuous Drain Current	I _D	360	-200	mA
Pulsed Drain Current (Note 4)	I _{DM}	1200	-900	mA
Power Dissipation	P _D	T _a =25°C		300
		Derate above 25°C		2.4
Operating Junction and Storage Temperature Range	T _J , T _{STG}	-55~150		°C
Typical Thermal resistance - Junction to Ambient (Note 3)	R _{θJA}	417		°C/W

APPLICATIONS

- Replace Digital Transistor, Level-Shifter
- Power Supply Converter Circuits
- Battery Operated Systems

Ordering Information

- Case: SOT563
- Shipping Qty: 3000/7inch Tape & Reel

N-Channel Electrical Characteristics ($T_A=25^{\circ}\text{C}$ unless otherwise noted)

PARAMETER	SYMBOL	TEST CONDITION	MIN.	TYP.	MAX.	UNITS
Static						
Drain-Source Breakdown Voltage	BV_{DSS}	$V_{GS}=0V, I_D=250\mu A$	60	-	-	V
Gate Threshold Voltage	$V_{GS(th)}$	$V_{DS}=V_{GS}, I_D=250\mu A$	1.0	1.6	2.5	V
Drain-Source On-State Resistance	$R_{DS(on)}$	$V_{GS}=10V, I_D=500mA$	-	1.5	2.0	Ω
		$V_{GS}=4.5V, I_D=250mA$	-	2.0	3.0	
Zero Gate Voltage Drain Current	I_{DSS}	$V_{DS}=60V, V_{GS}=0V$	-	-	1	μA
Gate-Source Leakage Current	I_{GSS}	$V_{GS}=\pm 20V, V_{DS}=0V$	-	-	± 10	μA
Dynamic (Note 5)						
Total Gate Charge	Q_g	$V_{DS}=25V, I_D=500mA,$ $V_{GS}=4.5V$	-	0.95	-	nC
Gate-Source Charge	Q_{gs}		-	0.34	-	
Gate-Drain Charge	Q_{gd}		-	0.32	-	
Input Capacitance	C_{iss}	$V_{DS}=25V, V_{GS}=0V,$ $f=1.0MHz$	-	36	-	pF
Output Capacitance	C_{oss}		-	11	-	
Reverse Transfer Capacitance	C_{rss}		-	6.6	-	
Turn-On Delay Time	$t_{d(on)}$	$V_{DD}=25V, I_D=500mA,$ $V_{GS}=10V,$ $R_G=6\Omega$ (Note 1,2)	-	2.3	-	ns
Turn-On Rise Time	t_r		-	20	-	
Turn-Off Delay Time	$t_{d(off)}$		-	7	-	
Turn-Off Fall Time	t_f		-	20	-	
Drain-Source Diode						
Maximum Continuous Drain-Source Diode Forward Current	I_S	---	-	-	360	mA
Diode Forward Voltage	V_{SD}	$I_S=150mA, V_{GS}=0V$	-	0.9	1.5	V

P-Channel Electrical Characteristics ($T_A=25^\circ\text{C}$ unless otherwise noted)

PARAMETER	SYMBOL	TEST CONDITION	MIN.	TYP.	MAX.	UNITS
Static						
Drain-Source Breakdown Voltage	BV_{DSS}	$V_{GS}=0V, I_D=-250\mu A$	-60	-	-	V
Gate Threshold Voltage	$V_{GS(th)}$	$V_{DS}=V_{GS}, I_D=-250\mu A$	-1.0	-1.5	-2.5	V
Drain-Source On-State Resistance	$R_{DS(on)}$	$V_{GS}=-10V, I_D=-500mA$	-	2.5	6	Ω
		$V_{GS}=-4.5V, I_D=-200mA$	-	3.0	7	
Zero Gate Voltage Drain Current	I_{DSS}	$V_{DS}=-48V, V_{GS}=0V$	-	-	-1	μA
Gate-Source Leakage Current	I_{GSS}	$V_{GS}=\pm 20V, V_{DS}=0V$	-	-	± 100	nA
Dynamic (Note 5)						
Total Gate Charge	Q_g	$V_{DS}=-25V, I_D=-100mA,$ $V_{GS}=-4.5V$	-	1.1	-	nC
Gate-Source Charge	Q_{gs}		-	0.3	-	
Gate-Drain Charge	Q_{gd}		-	0.2	-	
Input Capacitance	C_{iss}	$V_{DS}=-25V, V_{GS}=0V,$ $f=1.0MHz$	-	51	-	μF
Output Capacitance	C_{oss}		-	15	-	
Reverse Transfer Capacitance	C_{rss}		-	2.2	-	
Turn-On Delay Time	$t_{d(on)}$	$V_{DD}=-25V, I_D=-100mA,$ $V_{GS}=-10V,$ $R_G=6\Omega$ (Note 1,2)	-	4.8	-	ns
Turn-On Rise Time	t_r		-	19	-	
Turn-Off Delay Time	$t_{d(off)}$		-	52	-	
Turn-Off Fall Time	t_f		-	32	-	
Drain-Source Diode						
Maximum Continuous Drain-Source Diode Forward Current	I_S	---	-	-	-200	mA
Diode Forward Voltage	V_{SD}	$I_S=-500mA, V_{GS}=0V$	-	-0.9	-1.5	V



Outline Drawing - SOT563 (unit: mm)

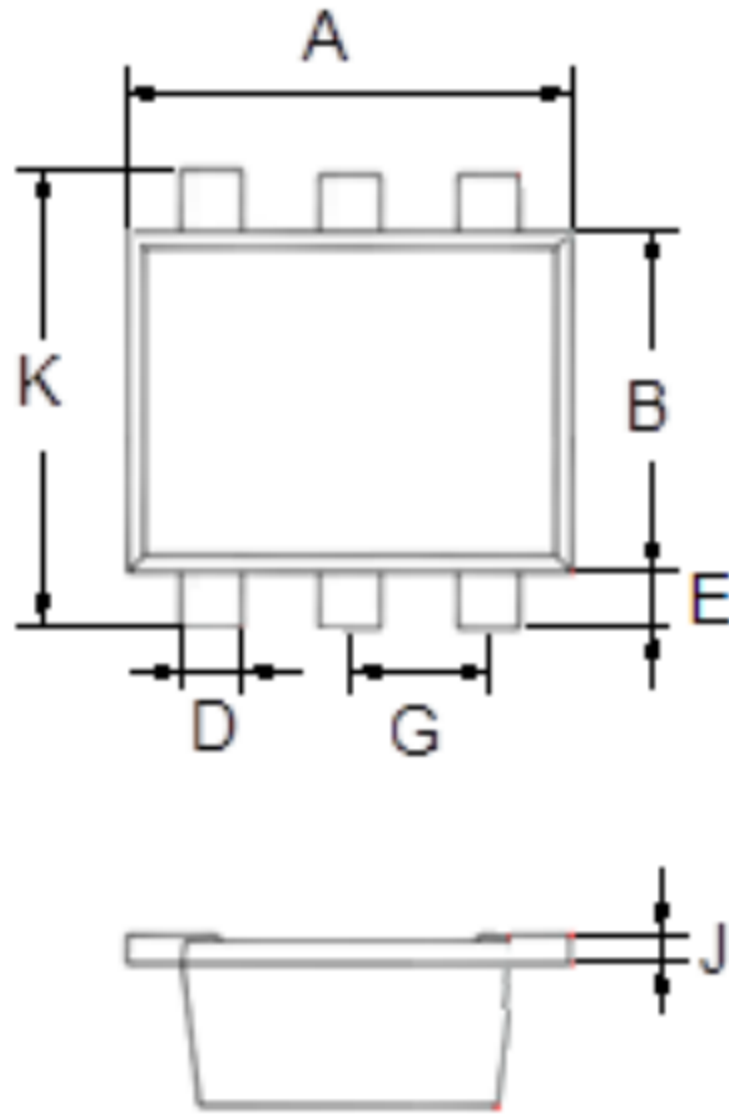

SOT-563		
Dimension	Min.	Max.
A	1.500	1.700
B	1.100	1.300
C	0.525	0.600
D	0.170	0.270
E	0.100	0.300
G	0.450	0.550
H	0.000	0.050
J	0.090	0.160
K	1.500	1.700

Mounting Pad Layout-SOT563 (unit: mm)

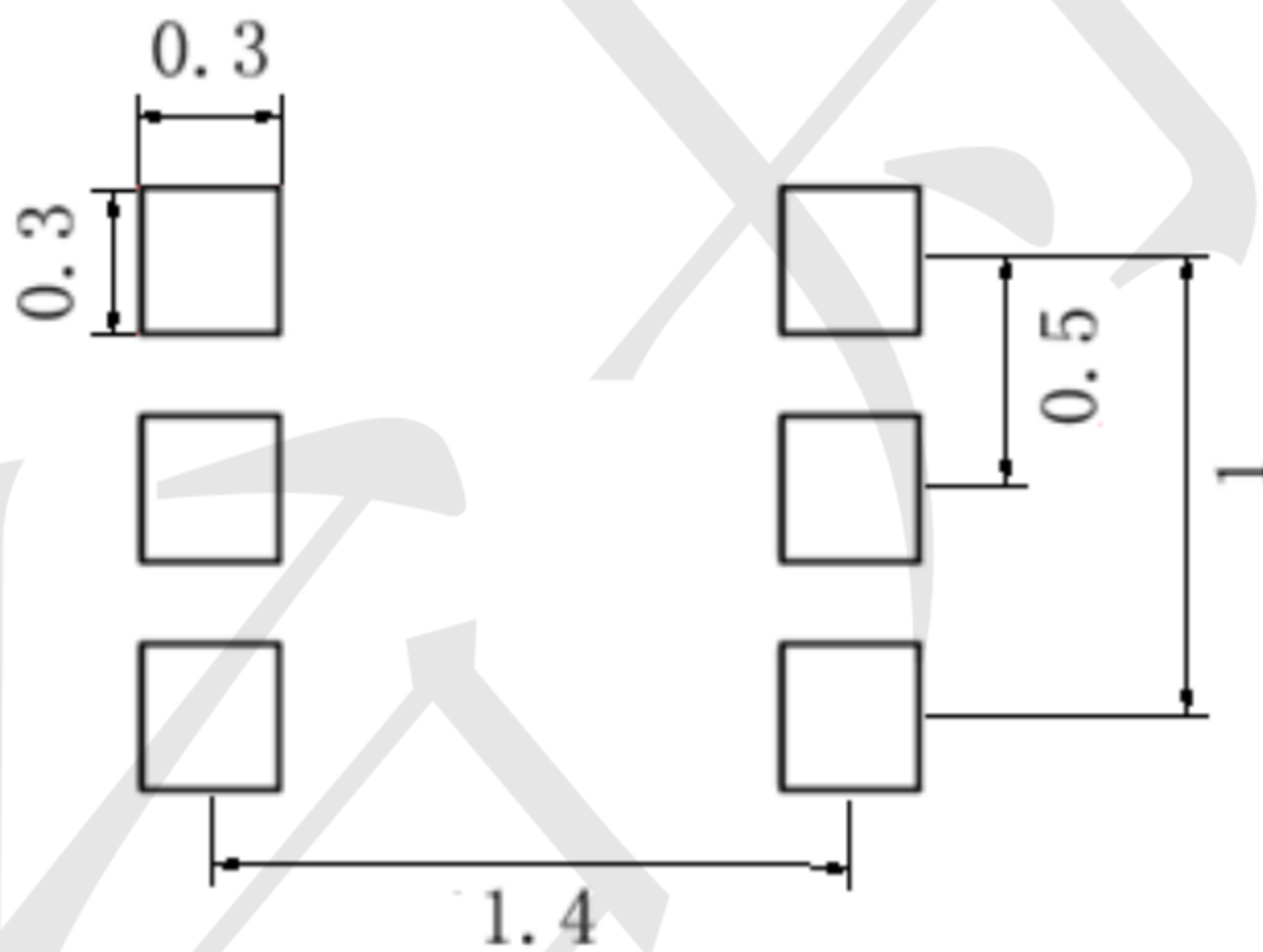

X-ON Electronics

Largest Supplier of Electrical and Electronic Components

Click to view similar products for [MOSFET](#) category:

Click to view products by [TECH PUBLIC](#) manufacturer:

Other Similar products are found below :

[IRFD120](#) [JANTX2N5237](#) [2SK2267\(Q\)](#) [BUK455-60A/B](#) [TK100A10N1,S4X\(S](#) [MIC4420CM-TR](#) [VN1206L](#) [NDP4060](#) [SI4482DY](#)
[IRS2092STRPBF-EL](#) [IPS70R2K0CEAKMA1](#) [TK31J60W5,S1VQ\(O](#) [TK31J60W,S1VQ\(O](#) [TK16J60W,S1VQ\(O](#) [2SK2614\(TE16L1,Q\)](#)
[DMN1017UCP3-7](#) [EFC2J004NUZTDG](#) [P85W28HP2F-7071](#) [DMN1053UCP4-7](#) [NTE2384](#) [DMC2700UDMQ-7](#) [DMN2080UCB4-7](#)
[DMN61D9UWQ-13](#) [US6M2GTR](#) [DMN31D5UDJ-7](#) [DMP22D4UFO-7B](#) [IPS60R3K4CEAKMA1](#) [DMN1006UCA6-7](#) [DMN16M9UCA6-7](#)
[STF5N65M6](#) [IRF40H233XTMA1](#) [STU5N65M6](#) [DMN6022SSD-13](#) [DMN13M9UCA6-7](#) [DMTH10H4M6SPS-13](#) [IPS60R360PFD7SAKMA1](#)
[DMN2990UFB-7B](#) [SSM3K35CT,L3F](#) [IPLK60R1K0PFD7ATMA1](#) [2N7002W-G](#) [MCAC30N06Y-TP](#) [IPWS65R035CFD7AXKSA1](#)
[MCQ7328-TP](#) [SSM3J143TU,LXHF](#) [DMN12M3UCA6-7](#) [PJMF280N65E1_T0_00201](#) [PJMF380N65E1_T0_00201](#)
[PJMF280N60E1_T0_00201](#) [PJMF600N65E1_T0_00201](#) [PJMF900N65E1_T0_00201](#)