

Features

- 10 μ A Current at no Load
- \pm 1% Output Accuracy
- 150mA Output Current
- Current Limit Protection

Applications

- Industrial Controls
- Home Automation
- Wireless power tools
- Motor driver and control board

PIN CONFIGURATION

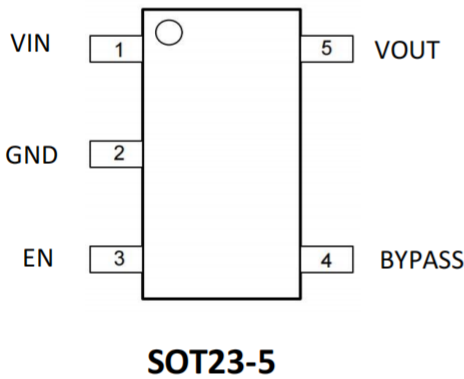

Pin Number	Pin Name	Pin Function
SOT23-5		
1	VIN	Input of Supply Voltage
2	GND	Ground
3	EN	Enable Control Input
4	BYPASS	BYPASS pin to achieve low noise performance, 1.2V
5	VOUT	Output of the Regulator

Ordering Information

LP2985-50DBVR

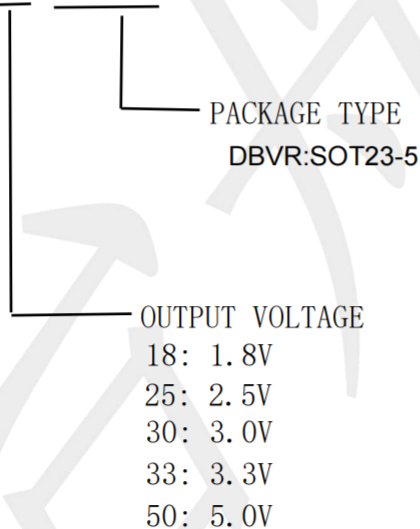

MARKING DIAGRAMS

- LP2985-18DBVR Marking: LPHL
- LP2985-33DBVR Marking: LPFG
- LP2985-50DBVR Marking: LPSG

Absolute Maximum Ratings

over operating free-air temperature range (unless otherwise noted)

		MIN	MAX	UNIT
V _{IN}	Continuous input voltage range	-0.3	18	V
V _{OUT}	Output voltage range	-0.3	9	
EN	EN pin voltage range	-0.3	18	
Current	Maximum output current	Internally limited		mA
Temperature	Operating junction, T _J	-55	150	°C
	Storage, T _{stg}	-65	150	

ESD Ratings

			VALUE	UNIT
V(ESD)	Electrostatic discharge	Human body model (HBM)	±2000	V
		Charged device model (CDM)	±500	

BLOCK DIAGRAM

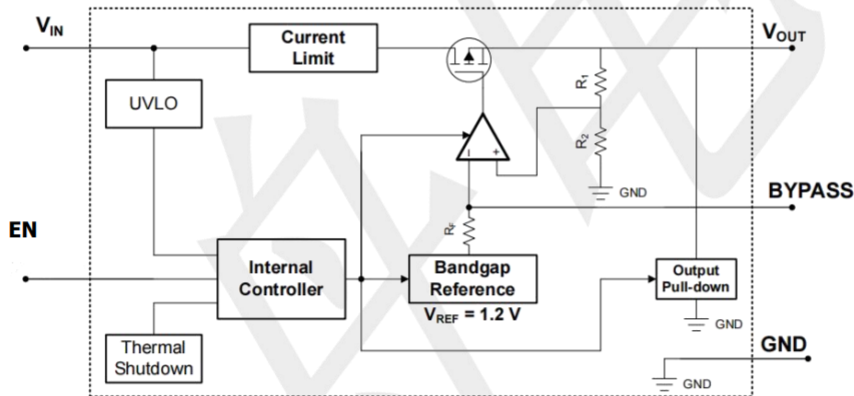

Typical Application Circuit

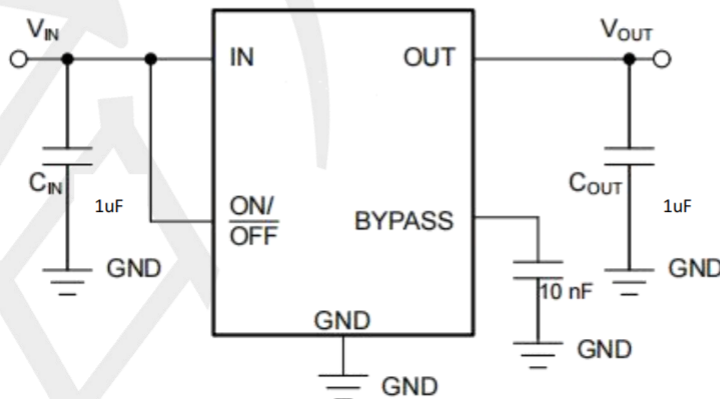

Electrical Characteristics

(VIN=15V, VEN=5V, TA=25°C, unless otherwise specified)

PARAMETER	SYMBOL	TEST Conditions	MIN	TYP	MAX	UNIT
Supply Voltage	VIN		2.2	--	18	V
Output current	IOUT		0	--	150	mA
DC Output Voltage Accuracy		IOUT = 0.1mA	-2	--	2	%
Dropout Voltage (VIN-VOUT)	IOUT = 100mA	VOUT = 1.2V	--	110	--	mV
		VOUT = 1.5V	--	106	--	
		VOUT = 1.8V	--	100	--	
		VOUT = 3.0V	--	95	--	
		VOUT = 3.3V	--	90	--	
		VOUT = 5.0V	--	85	--	
Ground Current (IOUT = 0mA)	IQ	VOUT = 3.3V	--	--	10	uA
Shutdown Ground Current	ISD	VEN = 0V,	--	0.01	0.5	
VOUT Shutdown Leakage Current	I _{LEAK}	VOUT = 0V	--	0.01	0.5	
Enable Threshold Voltage	V _{IH}	EN Rising	1.1	--	--	V
	V _{IL}	EN Falling	--	--	0.4	
EN Input Current	I _{EN}	VEN = 16V	--	10	100	nA
Line Regulation	ΔLINE	IOUT = 1mA, 10 ≤ VIN ≤ 18V	--	0.3	--	%
Load Regulation	ΔLOAD	10mA ≤ IOUT ≤ 100mA	--	0.3	--	
Output Current Limit	I _{LIM}	VOUT = 0.9 × VOUT(NOM)	150	200	--	mA
Power Supply Rejection Ratio	PSRR	VOUT = 5V, IOUT = 30mA, VIN = 12V, f = 1kHz	--	70	--	dB
Thermal Shutdown Temperature	TSD	IOUT = 10mA	--	160	--	°C
Thermal Shutdown Hysteresis	ΔTSD		--	15	--	
Package Thermal Resistance (Note 1)	TJA	Thermal Resistance Junction-to-Ambient	--	200	--	°C/W

Note: 1. Test condition: For SOT23-5, the device is mounted on FR-4 substrate PC board, with minimum recommended pad layout.

Typical Operating Characteristics (25 °C, unless otherwise noted)

Unless otherwise specified: TA = 25 °C, VIN = VO(NOM) + 1 V, COUT = 1 μF, CIN = 1 μF all voltage options, EN pin tied to VIN.

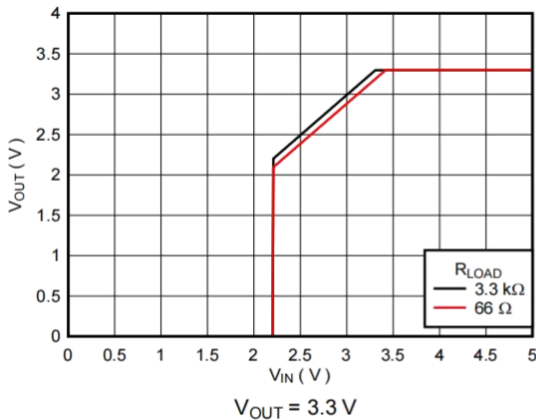

Output Voltage versus VIN

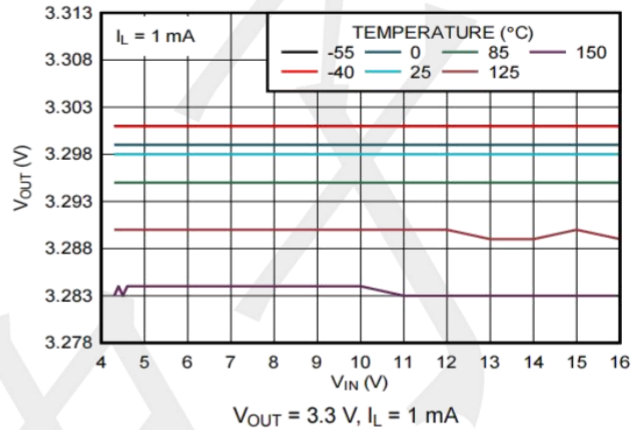

Output Voltage versus VIN and Temperature

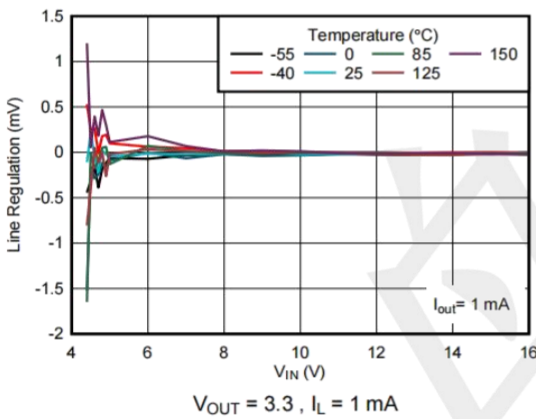

Line Regulation versus VIN & Temperature

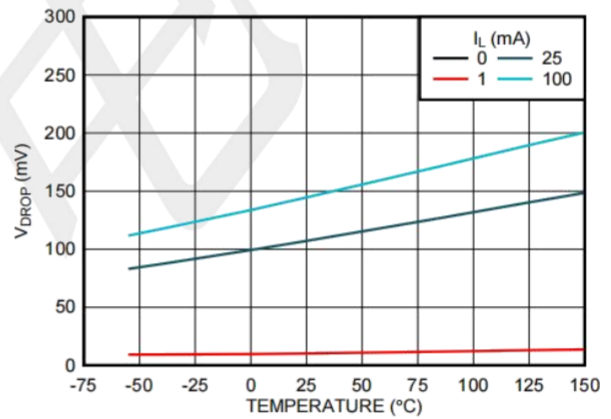

Dropout Voltage (VDO) versus Temperature

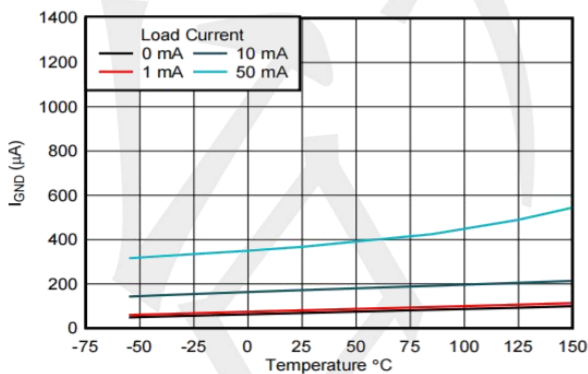

Ground Pin Current (I_{GND}) versus Temperature

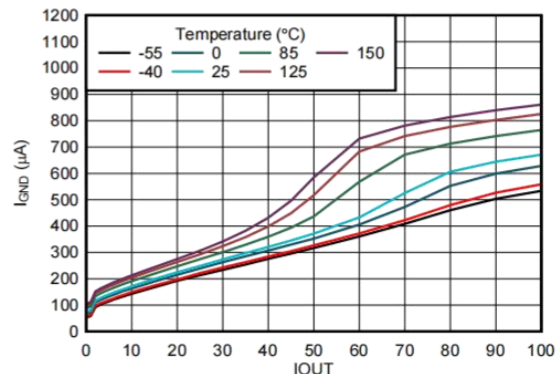

Ground Pin Current (I_{GND}) versus Load Current

Package informantion

SOT23-5

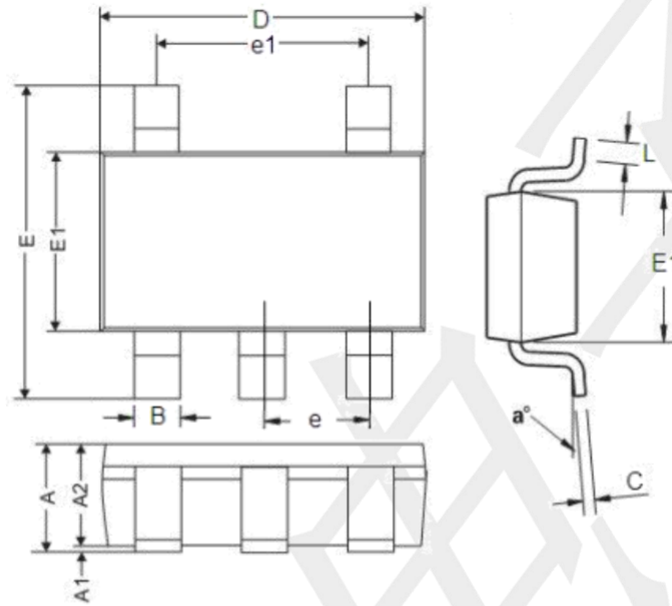

参数	尺寸 (mm)		尺寸 (Inch)	
	最小值	最大值	最小值	最大值
A	0.9	1.45	0.0354	0.0570
A1	0	0.15	0	0.0059
A2	0.9	1.3	0.0354	0.0511
B	0.2	0.5	0.0078	0.0196
C	0.09	0.26	0.0035	0.0102
D	2.7	3.10	0.1062	0.1220
E	2.2	3.2	0.0866	0.1181
E1	1.30	1.80	0.0511	0.0708
e	0.95REF		0.0374REF	
e1	1.90REF		0.0748REF	
L	0.10	0.60	0.0039	0.0236
a°	0°	30°	0°	30°

X-ON Electronics

Largest Supplier of Electrical and Electronic Components

Click to view similar products for [Linear Voltage Regulators](#) category:

Click to view products by [TECH PUBLIC](#) manufacturer:

Other Similar products are found below :

[LV5684PVD-XH](#) [MCDTSA6-2R](#) [L7815ACV-DG](#) [714954EB](#) [ZMR500QFTA](#) [BA033LBSG2-TR](#) [LV5680P-E](#) [L79M05T-E](#) [L78LR05D-MA-E](#) [NCV317MBTG](#) [NTE7227](#) [MP2018GZD-33-P](#) [MP2018GZD-5-P](#) [LV5680NPVC-XH](#) [LT1054CN8](#) [UA78L09CLP](#) [UA78L09CLPR](#) [CAT6221-PPTD-GT3](#) [MC78M09CDTRK](#) [NCV51190MNTAG](#) [78M05](#) [HT7150-1](#) [UM1540DB-18](#) [XC6234H281VR-G](#) [WL2834CA-6/TR](#) [TPL730F33-5TR](#) [TLS850F1TA](#) [V50](#) [TPS549B22RVFR](#) [UM1540DB-33](#) [WL9200P3-50B](#) [WL9100P3-33B](#) [XC6219B152MR](#) [WL2855K33-3/TR](#) [PJ54BM33SE](#) [PJ9500M25SA](#) [MD7218E33PC1](#) [H7533-2PR](#) [SK7812AU](#) [SD1A30](#) [78L33](#) [TP78L33T3](#) [SK6513ST3A-50](#) [SK6054D4-09](#) [SK6054D4-18](#) [SK6054D4-11](#) [SK6054D4-10](#) [LM79L12F](#) [HLP2985AIM5X-5.0](#) [HLP2992AIM5X-5.0/NOPB](#) [HMIC5205-5.0YM5-TR](#)