

Features

- Operation Voltage Range: 1.65V ~ 5.5V
- Power Down Protection
- $\pm 24\text{mA}$ Output Drive ($V_{CC}=3.0\text{V}$)
- Low Power Consumption, 10- μA Max ICC
- Power Down High Impedance Inputs / Outputs

Applications

- AV Receiver
- Audio Dock: Portable
- Blu-ray Player and Home Theater
- Embedded PC
- Personal Digital Assistant(PDA)
- Power: Telecom/Server AC/DC Supply: Single Controller: Analog and Digital

General Description

The is a single Schmitt-trigger inverter, it provides the function $Y=\bar{A}$. The device have different input threshold levels for positive going (V_{T+}) and negative-going (V_{T-}) signals because of the Schmitt-trigger action in the input.

Ordering Information

ORDER NUMBER	PACKAGE DESCRIPTION	PACKAGE OPTION	Marking
NC7SZ14P5X	SOT353	Tape and Reel,3000	Z14C
NC7SZ14M5X	SOT23-5	Tape and Reel,3000	7Z14D

Pin Configuratio

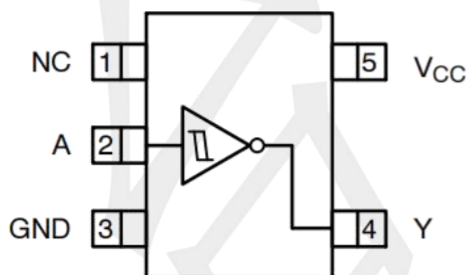

SOT353 / SOT23-5

Function Table

INPUT(A)	OUTPUT(Y)
L	H
H	L

Note:H: HIGH voltage level;L: LOW voltage level.

Absolute Maximum Ratings

PARAMETER	SYMBOL	CONDITIONS	RATINGS	UNIT
Supply Voltage	VCC		-0.5 ~ +6.5	V
Input Voltage	VIN		-0.5 ~ +6.5	V
Output Voltage	VOUT	Output in the Power-off state	-0.5 ~ +6.5	V
		Output in the High or Low state	-0.5 ~ VCC+0.5	V
VCC or GND Current	ICC	Output in the Power-off state	±100	mA
Continuous Output Current	IOUT	VOUT=0~VCC	±50	mA
Input Clamp Current	I _{IK}	V _{IN} <0	-50	mA
Output Clamp Current	I _{OK}	V _{OUT} <0	-50	mA
Storage Temperature Range	TSTG		-65 ~ +150	°C
Junction to Ambient	θ _{JA}	SOT353	280	°C/W

Note: Absolute maximum ratings are those values beyond which the device could be permanently damaged. Absolute maximum ratings are stress ratings only and functional device operation is not implied.

Recommended Operating Conditions

PARAMETER	SYMBOL	TEST CONDITIONS	MIN	TYP	MAX	UNIT
Supply Voltage	VCC	Operating	1.65	--	5.5	V
		Data retention only	1.5	--	--	V
Input Voltage	VIN		0	--	5.5	V
Output Voltage	VOUT	High or low state	0	--	VCC	V
Operating Temperature	TA		-40	--	125	°C

Electrical Characteristics (unless otherwise specified)

PARAMETER	SYM BOL	TEST Conditions	TA =25°C			TA =-40°C~+125°C			UNIT
			MIN	TYP	MAX	MIN	TYP	MAX	
Positive-Going Input Threshold Voltage	V _{T+}	V _{CC} =1.65V	0.79	--	1.16	0.76	--	1.16	V
		V _{CC} =2.3V	1.11	--	1.56	1.07	--	1.56	V
		V _{CC} =3V	1.5	--	1.87	1.47	--	1.87	V
		V _{CC} =4.5V	2.16	--	2.74	2.13	--	2.74	V
		V _{CC} =5.5V	2.61	--	3.33	2.58	--	3.33	V
Negative-Going Input Threshold Voltage	V _{T-}	V _{CC} =1.65V	0.39	--	0.62	0.39	--	0.65	V
		V _{CC} =2.3V	0.58	--	0.87	0.58	--	0.9	V
		V _{CC} =2.7V	0.84	--	1.14	0.84	--	1.17	V
		V _{CC} =4.5V	1.41	--	1.79	1.41	--	1.82	V
		V _{CC} =5.5V	1.87	--	2.29	1.87	--	2.31	V
Hysteresis Voltage (V _{T+} -V _{T-})	ΔV _T	V _{CC} =1.65V	0.37	--	0.62	0.3	--	0.62	V
		V _{CC} =2.3V	0.48	--	0.77	0.42	--	0.77	V
		V _{CC} =2.7V	0.56	--	0.87	0.5	--	0.87	V
		V _{CC} =4.5V	0.71	--	1.04	0.65	--	1.04	V
		V _{CC} =5.5V	0.71	--	1.11	0.65	--	1.11	V
High-Level Output Voltage	V _{OH}	V _{CC} =1.65 ~ 5.5V, I _{OH} =-100μA	V _{CC} -0.1	--	--	V _{CC} -0.1	--	--	V
		V _{CC} =1.65V, I _{OH} =-4mA	1.2	1.54	--	0.95	--	--	V
		V _{CC} =2.3V, I _{OH} =-8mA	1.9	2.15	--	1.7	--	--	V
		V _{CC} =2.7V, I _{OH} =-16mA	2.2	2.5	--	1.9	--	--	V
		V _{CC} =3.0V, I _{OH} =-24mA	2.3	2.62	--	2.0	--	--	V
		V _{CC} =4.5V, I _{OH} =-32mA	3.8	4.11	--	3.4	--	--	V
Low-Level Output Voltage	V _{OL}	V _{CC} =1.65 ~ 5.5V, I _{OL} =100μA	--	--	0.1	--	--	0.1	V
		V _{CC} =1.65V, I _{OL} =4mA	--	0.07	0.45	--	--	0.7	V
		V _{CC} =2.3V, I _{OL} =8mA	--	0.12	0.3	--	--	0.45	V
		V _{CC} =2.7V, I _{OL} =16mA	--	0.17	0.4	--	--	0.6	V
		V _{CC} =3.0V, I _{OL} =24mA	--	0.33	0.55	--	--	0.8	V
		V _{CC} =4.5V, I _{OL} =32mA	--	0.39	0.55	--	--	0.8	V
Input Leakage Current	I _{I(LEAK)}	V _{CC} =0 ~ 5.5V, V _{IN} =5.5V or GND	--	±0.1	±5	--	--	±5	uA
Power OFF Leakage Current	I _{OFF}	V _{CC} =0V, V _{IN} or V _{OUT} =5.5V	--	±0.1	±10	--	--	±10	uA
Quiescent Supply Current	I _Q	V _{CC} =1.65 ~ 5.5V, V _{IN} =V _{CC} or GND, I _{OUT} =0A	--	0.1	10	--	--	10	uA
Additional Quiescent Supply Current Per Input Pin	ΔI _Q	V _{CC} =3 ~ 5.5V, One input at V _{CC} -0.6V, Other inputs at V _{CC} or GND	--	5	500	--	--	500	uA

OPERATING CHARACTERISTICS (f=10MHz, TA =25°C , unless otherwise specified)

PARAMETER	SYMBOL	TEST Conditions	MIN	TYP	MAX	UNIT
Input Capacitance	C _I	V _{CC} =3.3V, V _{IN} =V _{CC} or GND	--	5	--	pF
Power Dissipation Capacitance	C _{PD}	V _{CC} =3.3V, V _{IN} =GND or V _{CC}	--	15.4	--	pF

SWITCHING CHARACTERISTICS (TA =25°C , unless otherwise specified)

PARAMETER	SYMBOL	TEST Conditions	TA =25°C			TA =-40°C~+125°C			UNIT
			MIN	TYP	MAX	MIN	TYP	MAX	
Propagation delay from input (A or B) to output(Y)	t _{PLH} / t _{PHL}	V _{CC} =1.65~1.95V, C _L =30 pF, R _L =1K	1	8	13	--	--	15	nS
		V _{CC} =2.3~2.7V, C _L =30 pF, R _L =500 Ω	0.7	5	9	--	--	11	nS
		V _{CC} =2.7V, C _L =50pF, R _L =500Ω	0.7	5	8	--	--	10	nS
		V _{CC} =3.0~3.6V, C _L =50pF, R _L =500Ω	0.7	4.5	7	--	--	9	nS
		V _{CC} =4.5~5.5V, C _L =50pF, R _L =500Ω	0.7	4	6	--	--	8	nS

TEST CIRCUIT AND WAVEFORMS

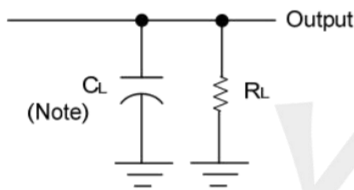

Note: C_L includes probe and jig capacitance.

V _{CC}	V _{IN}	t _r , t _f	V _M	C _L	R _L
1.65V~1.95V	V _{CC}	≤2ns	$\frac{V_{CC}}{2}$	30pF	1kΩ
2.3V~2.7V	V _{CC}	≤2ns	$\frac{V_{CC}}{2}$	30pF	500Ω
2.7V	2.7V	≤2.5ns	1.5V	50pF	500Ω
3.0V~3.6V	2.7V	≤2.5ns	1.5V	50pF	500Ω
4.5V~5.5V	V _{CC}	≤2.5ns	$\frac{V_{CC}}{2}$	50pF	500Ω

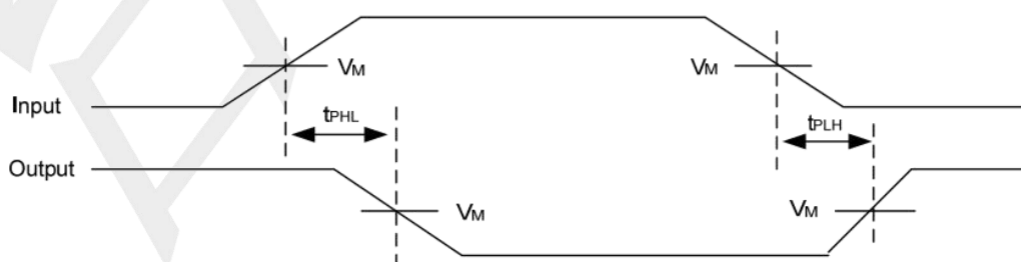

Package information

SOT353 (Unit: mm)

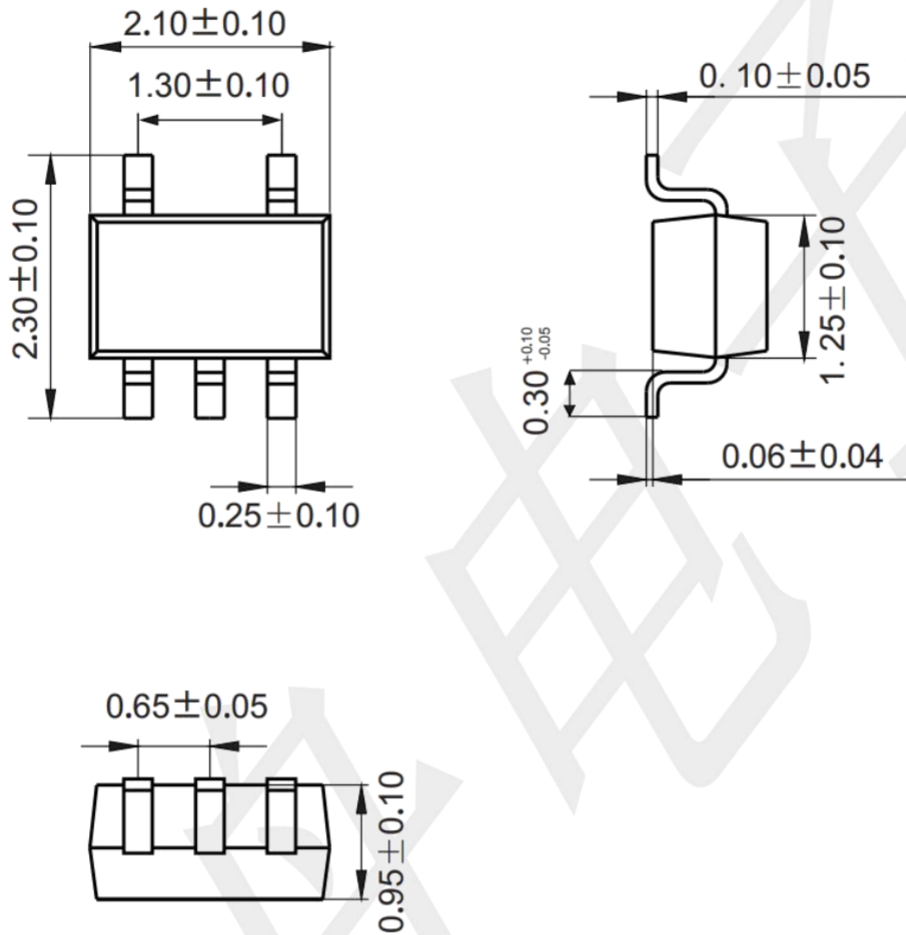

Mounting Pad Layout (unit: mm)

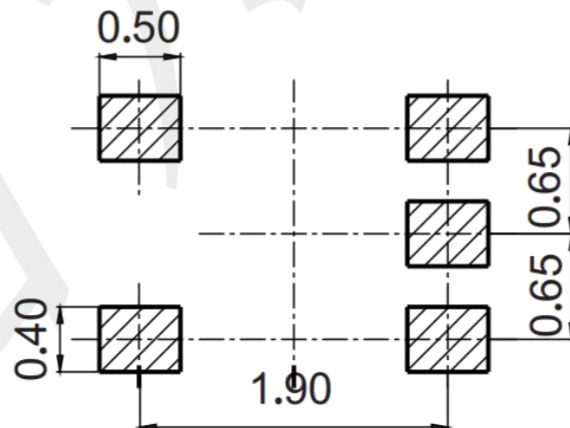

Package information

SOT23-5 (Unit: mm)

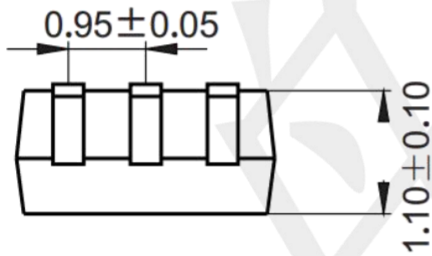
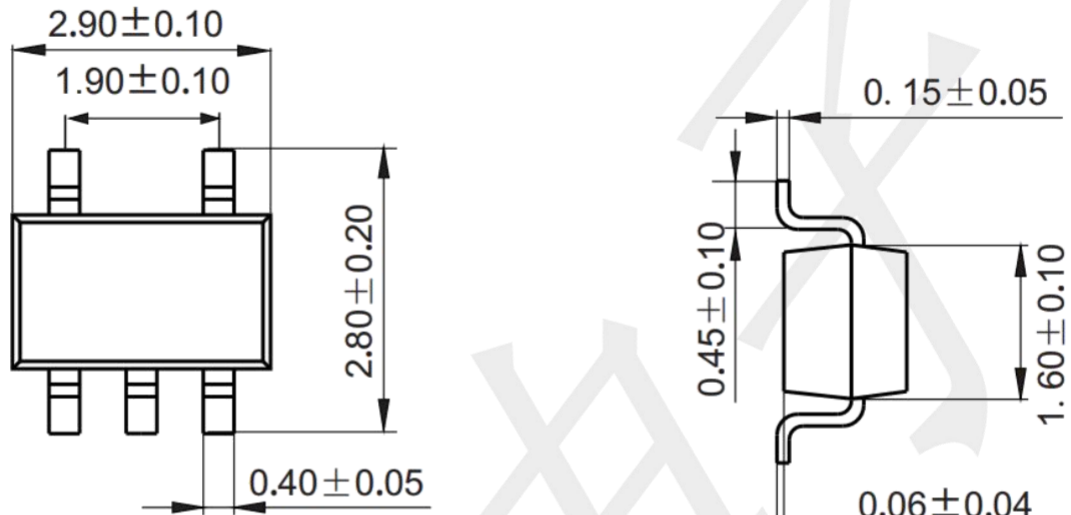

Mounting Pad Layout (unit: mm)

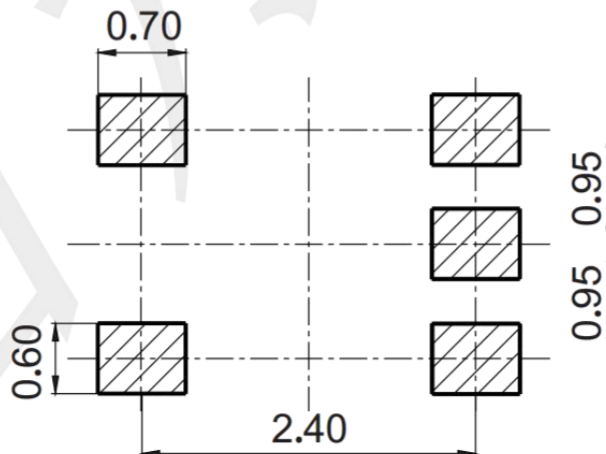

X-ON Electronics

Largest Supplier of Electrical and Electronic Components

Click to view similar products for [Inverters](#) category:

Click to view products by [TECH PUBLIC](#) manufacturer:

Other Similar products are found below :

[E5-652Z](#) [NLX2G04BMX1TCG](#) [CD4009UBE](#) [TC4584BFN](#) [NL17SG14AMUTCG](#) [NLU2GU04BMX1TCG](#) [NLV17SZ14DFT2G](#)
[NLV74HC04ADTR2G](#) [NLU1G04AMUTCG](#) [NLX2G04CMUTCG](#) [NLX2G04AMUTCG](#) [NLV27WZ04DFT1G](#) [NLU1G04CMUTCG](#)
[NL17SZU04P5T5G](#) [74LVC06ADTR2G](#) [74LVC04ADR2G](#) [NLV37WZ04USG](#) [NLX3G14FMUTCG](#) [NL17SZ04P5T5G](#) [NL17SG14P5T5G](#)
[NLV27WZU04DFT2G](#) [NLV17SG14DFT2G](#) [NLVHC1G04DFT2G](#) [MC14069UBD](#) [NLU3G14CMX1TCG](#) [NLX2G14BMX1TCG](#)
[NLX2GU04AMX1TCG](#) [74HCT04DT](#) [74HCT14DT](#) [74LCX14FT\(AJ\)](#) [EG8015](#) [GN14D](#) [GN4069](#) [74HC04DM/TR](#) [HG74HC04M/TR](#)
[CD40106DM/TR](#) [CD4007BE](#) [74HC14DN](#) [74HC14DM/TR](#) [CD4069UBE](#) [74HC125M/TR](#) [CD4069UBMT/TR](#) [HG74HC04MT/TR](#)
[74HC14DMT/TR](#) [74HC04DN](#) [HT74HC04ARZ](#) [HT40106ARZ](#) [74HC14-HXY](#) [IW4069UBN](#) [RS1GT04XC5](#)