

General Description

The TP132C series are a group of low-dropout (LDO) voltage regulators offering the benefits of wide input voltage range from 1.2V to 5.5V, low dropout voltage, low power consumption, and miniaturized packaging. Quiescent current of only 2μA makes these devices ideal for powering the battery-powered, always-on systems that require very little idle-state power dissipation to a longer service life. There is an option of

shutdown mode by selecting the parts with the EN pin and pulling it low. The shutdown current in this mode goes down to only 10nA (typical).

The TP132C series of linear regulators are stable with the ceramic output capacitor over its wide input range from 1.2V to 5.5V and the entire range of output load current (0mA to 300mA).

Features

- 2μA Ground Current at no Load
- ±2% Output Accuracy
- 300mA Output Current
- 10nA Disable Current (by option)
- Wide Operating Input Voltage Range: 1.2V to 5.5V
- Dropout Voltage: 0.16V at 300mA/ VOUT 3.3V
- Support Fixed Output Voltage 0.8V, 0.9V, 1.2V, 1.5V, 1.8V, 2.5V, 2.8V, 3.0V, 3.3V
- Adjustable Output Voltage Available by Specific Application
- Stable with Ceramic or Tantalum Capacitor
- Current Limit Protection
- Over-Temperature Protection
- SOT-23-3, SOT-23-5, DFN-4L 1x1 and DFN-6L 2x2 Packages Available

Applications

- CDM/GSM mobile phone
- PDAs /MP3
- Audio/Video equipment

Ordering Information

TP132C15D4

S5:SOT23-5 Package
S3:SOT23-3 Package
D4:DFN1X1 Package
D6:DFN2X2 Package

Output voltage: 12=1.2V
15=1.5V
18=1.8V
30=3.0V
33=3.3V
XX=X.XV

Package informantion

DFN1X1-4 Outline Dimensions

DFN-4L

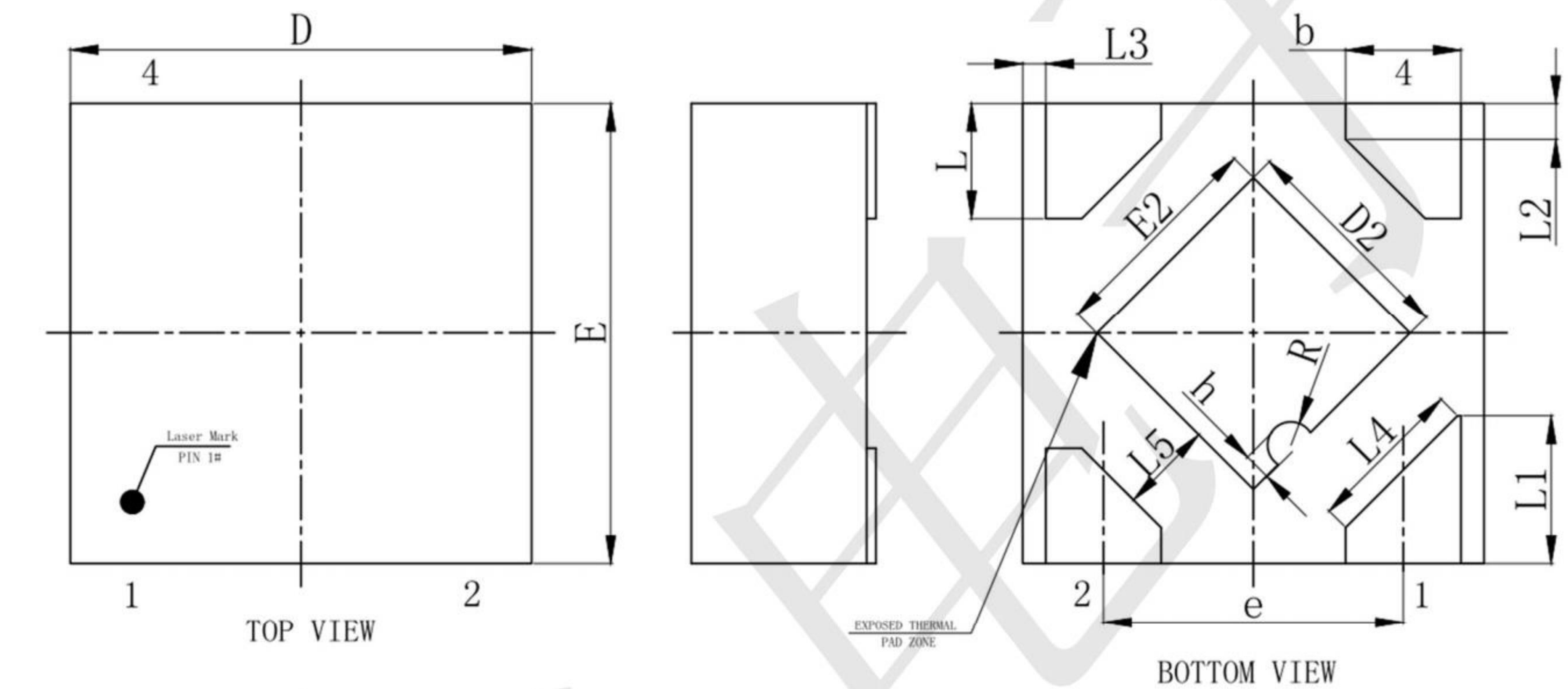

SYMBOL	MILLIMETER		
	MIN	NOM	MAX
A	0.35	-	0.40
A1	0.00	0.02	0.05
b	0.20	0.25	0.30
c	0.07	0.12	0.17
D	0.95	1.00	1.05
D2	0.38	0.48	0.58
e	0.65BSC		
E	0.95	1.00	1.05
E2	0.38	0.48	0.58
L	0.20	0.25	0.30
L1	0.27	0.32	0.37
L2	0.077REF		
L3	0.05REF		
L4	0.34REF		
L5	0.20REF		
R	0.05REF		
h	0.06REF		

Package informantion

3-pin SOT23-3 Outline Dimensions

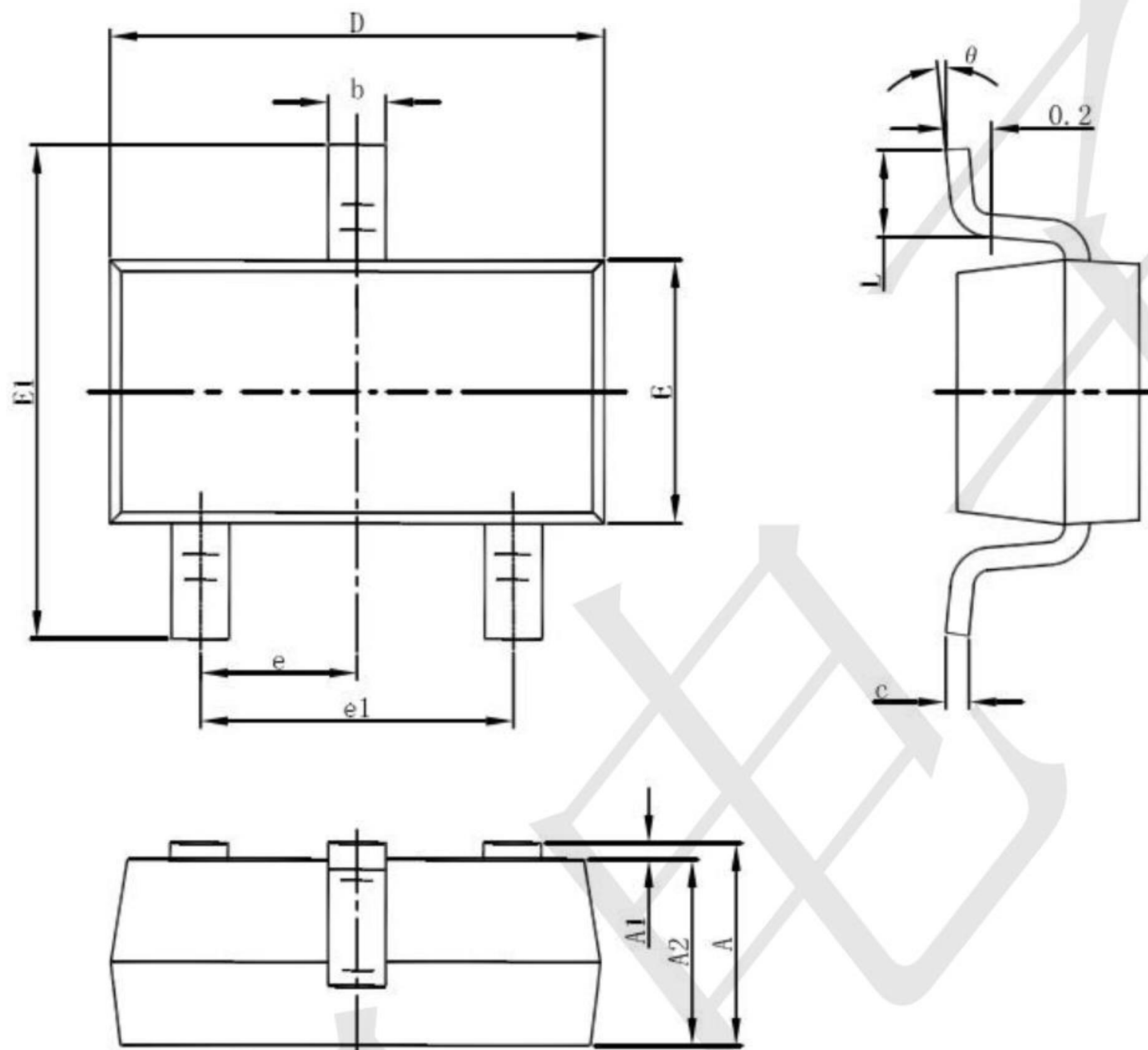

Symbol	Dimensions In Millimeters		Dimensions In Inches	
	Min	Max	Min	Max
A	1.050	1.250	0.041	0.049
A1	0.000	0.100	0.000	0.004
A2	1.050	1.150	0.041	0.045
b	0.300	0.500	0.012	0.020
c	0.100	0.200	0.004	0.008
D	2.820	3.020	0.111	0.119
E	1.500	1.700	0.059	0.067
E1	2.650	2.950	0.104	0.116
e	0.950(BSC)		0.037(BSC)	
e1	1.800	2.000	0.071	0.079
L	0.300	0.600	0.012	0.024
theta	0°	8°	0°	8°

Package informantion

SOT23-5

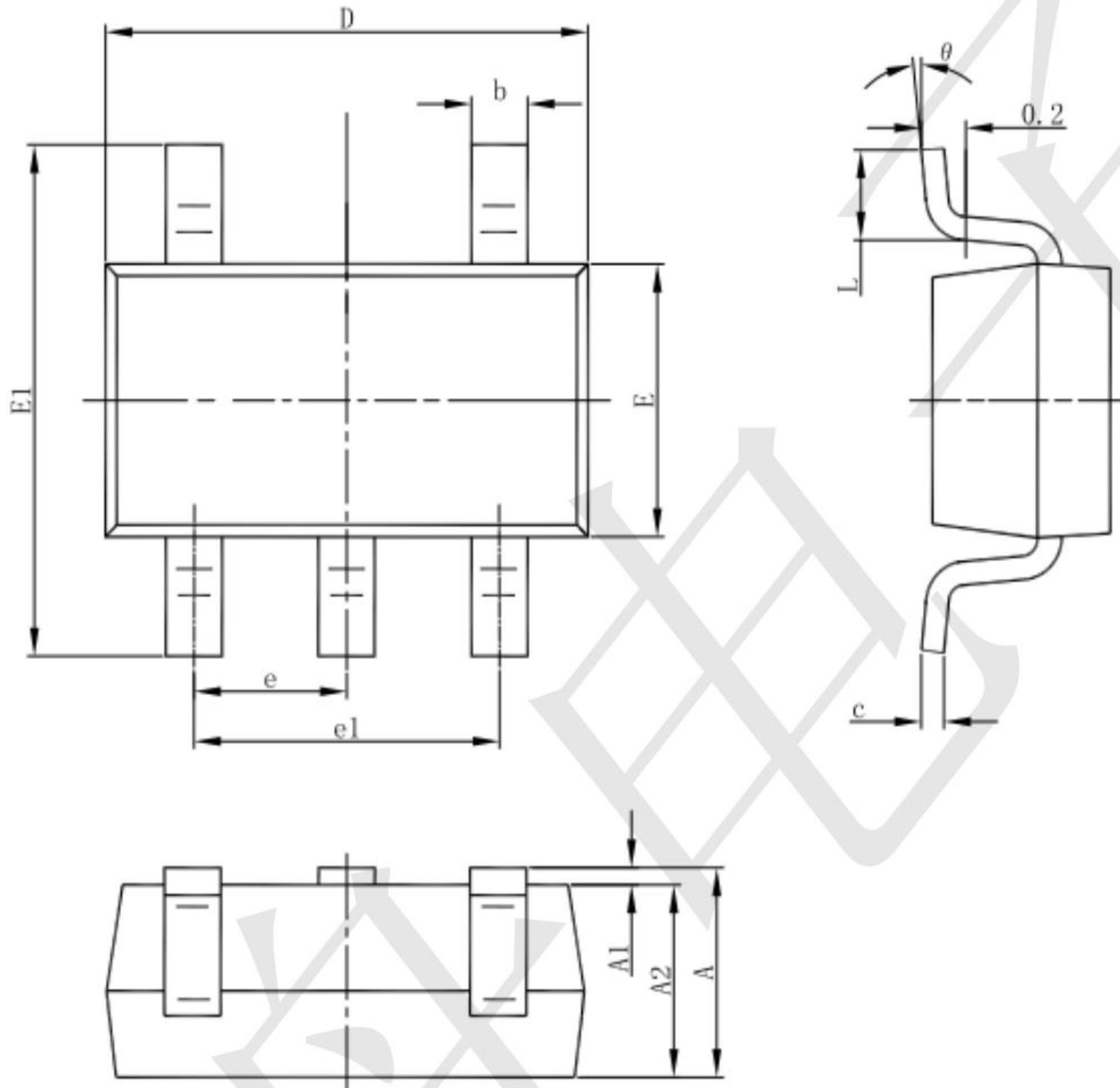

Symbol	Dimensions In Millimeters		Dimensions In Inches	
	Min	Max	Min	Max
A	1.050	1.250	0.041	0.049
A1	0.000	0.100	0.000	0.004
A2	1.050	1.150	0.041	0.045
b	0.300	0.500	0.012	0.020
c	0.100	0.200	0.004	0.008
D	2.820	3.020	0.111	0.119
E	1.500	1.700	0.059	0.067
E1	2.650	2.950	0.104	0.116
e	0.950(BSC)		0.037(BSC)	
e1	1.800	2.000	0.071	0.079
L	0.300	0.600	0.012	0.024
θ	0°	8°	0°	8°

BLOCK DIAGRAM

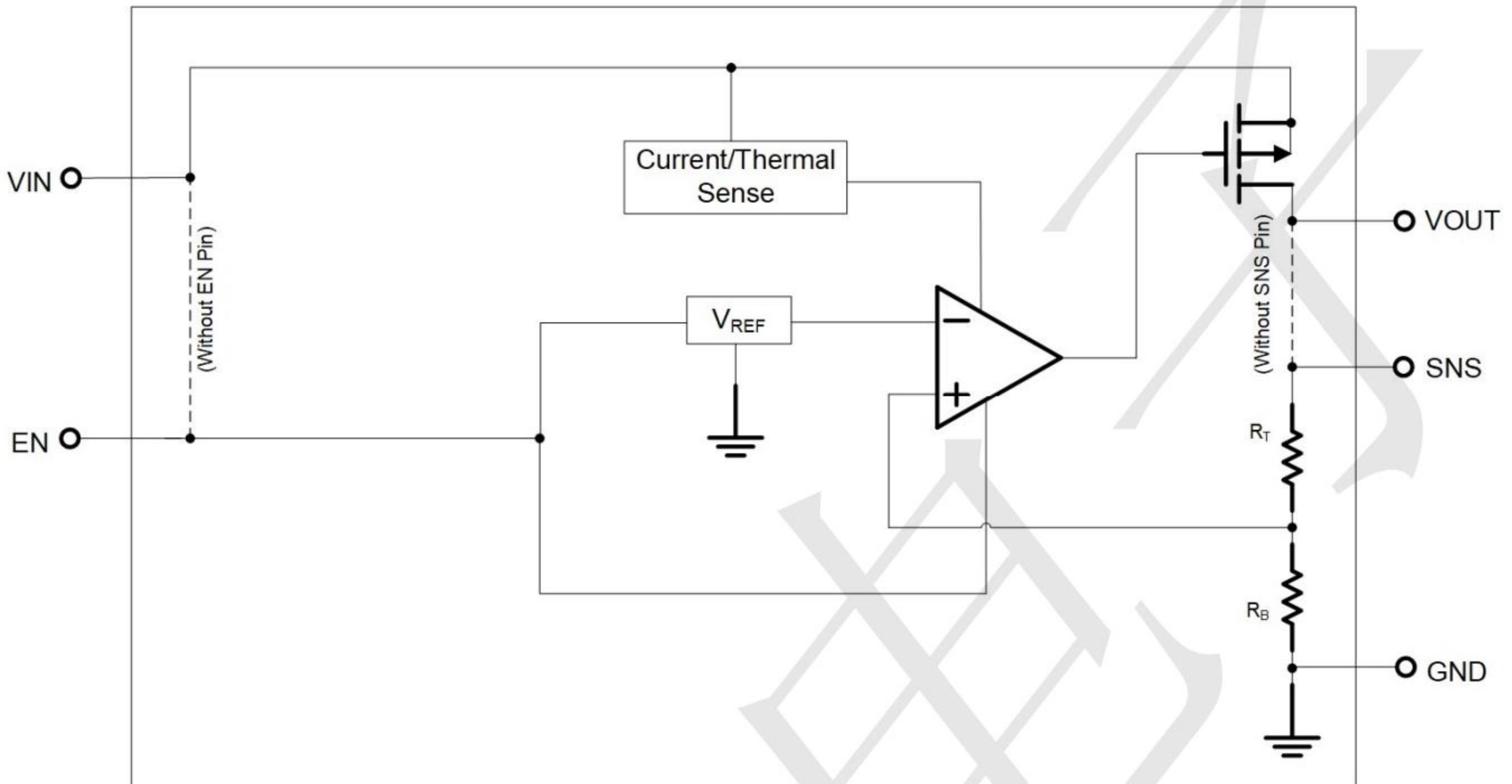

PIN CONFIGURATION

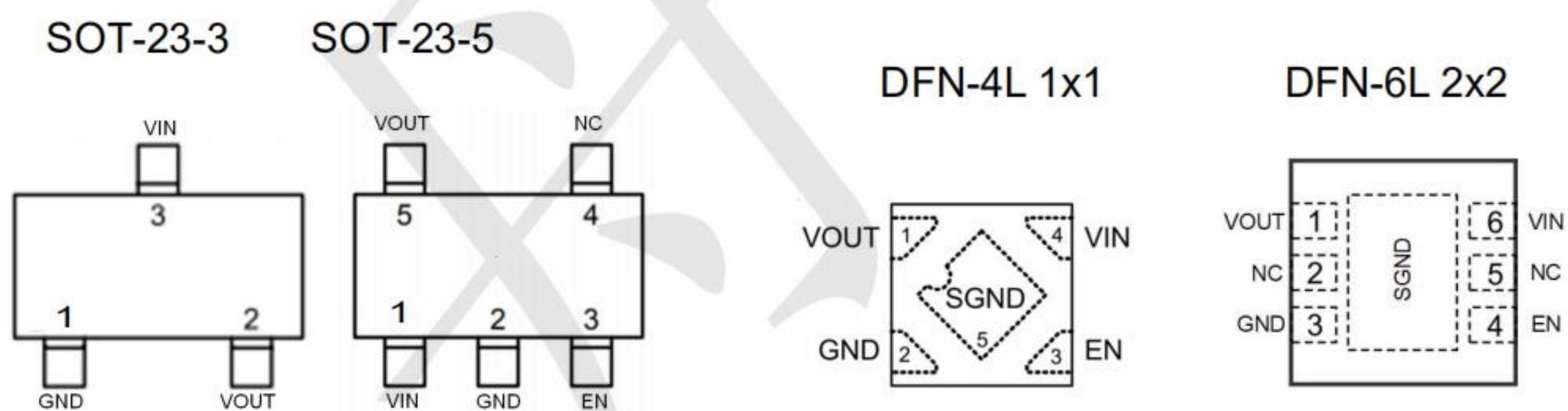

Pin No				Pin Name	Pin Function
SOT-23-3	SOT-23-5	DFN-1X1	DFN-2X2		
1	2	2	3	GND	Ground
2	5	1	1	VOUT	Output of the Regulator
3	1	4	6	VIN	Input of Supply Voltage.
	3	3	4	EN	Enable Control Input.
	4		2,5	NC	No internal connection

Absolute Maximum Rating ($T_A=25^{\circ}\text{C}$ unless otherwise noted)

VIN to GND	-----	-0.3V to 6.5V
VOUT, EN, SNS to GND	-----	-0.3V to 6V
VOUT to VIN	-----	-6V to 0.3V
Package Thermal Resistance (Note 2)		
SOT-23-5, SOT-23-3, θ_{JA}	-----	200 $^{\circ}\text{C} / \text{W}$
DFN-4L 1x1, θ_{JA}	-----	130 $^{\circ}\text{C} / \text{W}$
DFN-6L 2x2, θ_{JA}	-----	95 $^{\circ}\text{C} / \text{W}$
Lead Temperature (Soldering, 10 sec.)	-----	260 $^{\circ}\text{C}$
Junction Temperature	-----	150 $^{\circ}\text{C}$
Storage Temperature Range	-----	-60 $^{\circ}\text{C}$ to 150 $^{\circ}\text{C}$
ESD Susceptibility		
HBM	-----	2KV
MM	-----	200V
CDM	-----	2KV

Recommended Operating Conditions

Input Voltage VIN	-----	1.2V to 5.5V
Junction Temperature Range	-----	-40 $^{\circ}\text{C}$ to 125 $^{\circ}\text{C}$
Ambient Temperature Range	-----	-40 $^{\circ}\text{C}$ to 85 $^{\circ}\text{C}$

Electrical Characteristics (T =25°C unless otherwise noted)

(V_{IN} =5V, V_{EN} = 5V T_A=25°C unless otherwise specified)

Parameter	Symbol	Test Conditions	Min	Typ	Max	Unit	
Supply Voltage	V _{IN}		1.2	--	5.5	V	
DC Output Voltage Accuracy		I _{LOAD} =0.1mA	-2		2	%	
Dropout Voltage (I _{LOAD} =300mA) (Note 3)	V _{DROP_3V}	V _{OUT} ≥ 3V	--	0.16		V	
	V _{DROP_2.8V}	V _{OUT} = 2.8V		0.18			
	V _{DROP_2.5V}	V _{OUT} = 2.5V		0.2			
	V _{DROP_1.8V}	V _{OUT} = 1.8V		0.25			
	V _{DROP_1.5V}	V _{OUT} = 1.5V		0.31			
	V _{DROP_1.2V}	V _{OUT} = 1.2V		0.41			
	V _{DROP_0.9V}	V _{OUT} = 0.9V		0.61			
Ground Current	I _Q	I _{LOAD} = 0mA		2		μA	
Shutdown Ground Current	I _{SD}	V _{EN} = 0V,		0.01	0.5	μA	
V _{OUT} Shutdown Leakage Current	I _{LEAK}	V _{OUT} = 0V		0.01	0.5		
SNS Input Current	I _{SNS}	SNS = V _{OUT}		0.7		μA	
Enable Threshold Voltage	V _{IH}	EN Rising			2	V	
	V _{IL}	EN Falling	0.6				
EN Input Current	I _{EN}	V _{EN} = 5V		10	100	nA	
Line Regulation	Δ _{LINE}	I _{LOAD} =30mA, 1.5V ≤ V _{IN} ≤ 5.5V or (V _{OUT} + 0.2V) ≤ V _{IN} ≤ 5.5V		0.2		%	
Load Regulation	Δ _{LOAD}	10mA ≤ I _{LOAD} ≤ 0.3A		0.2		%	
Output Current Limit	I _{LIM}	V _{OUT} =0	301	600		mA	
Power Supply Rejection Ratio (I _{LOAD} =5mA)	PSRR	V _{OUT} =1.2V, V _{IN} = 2V	f = 100Hz	--	80	--	dB
			f = 1kHz	--	75	--	
Output Voltage Noise (BW = 10Hz to 100kHz, C _{OUT} =1μF,)		V _{IN} = 3.5V I _{LOAD} =0.1A	V _{OUT} =0.9V	--	40	--	μV _{RMS}
			V _{OUT} =2.8V	--	50	--	
Thermal Shutdown Temperature	T _{SD}	I _{LOAD} =10mA	--	155	--	°C	
Thermal Shutdown Hysteresis	ΔT _{SD}		--	15	--	°C	

TYPICAL APPLICATION

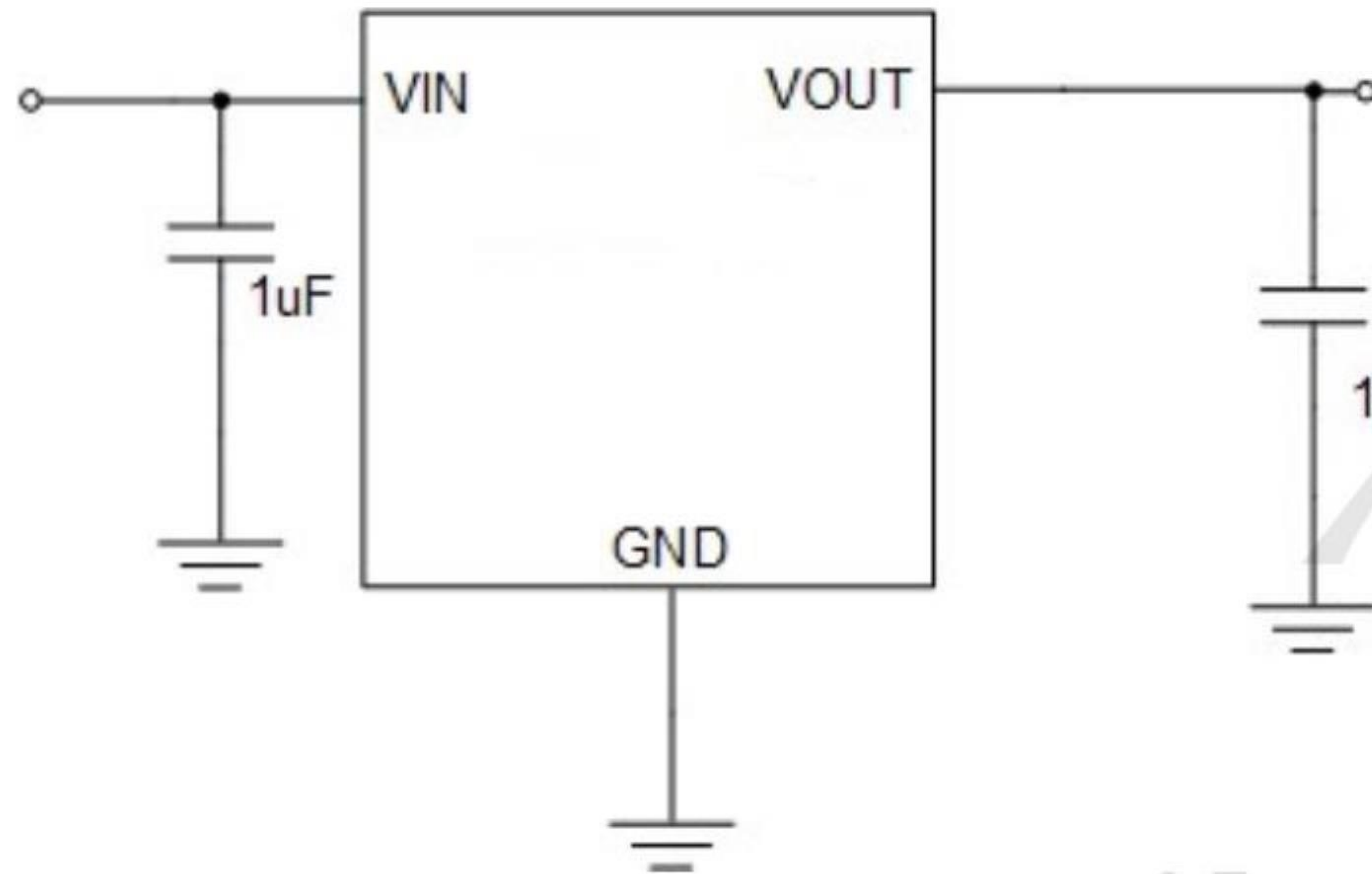

Figure 1: Application circuit of Fixed V_{OUT} LDO

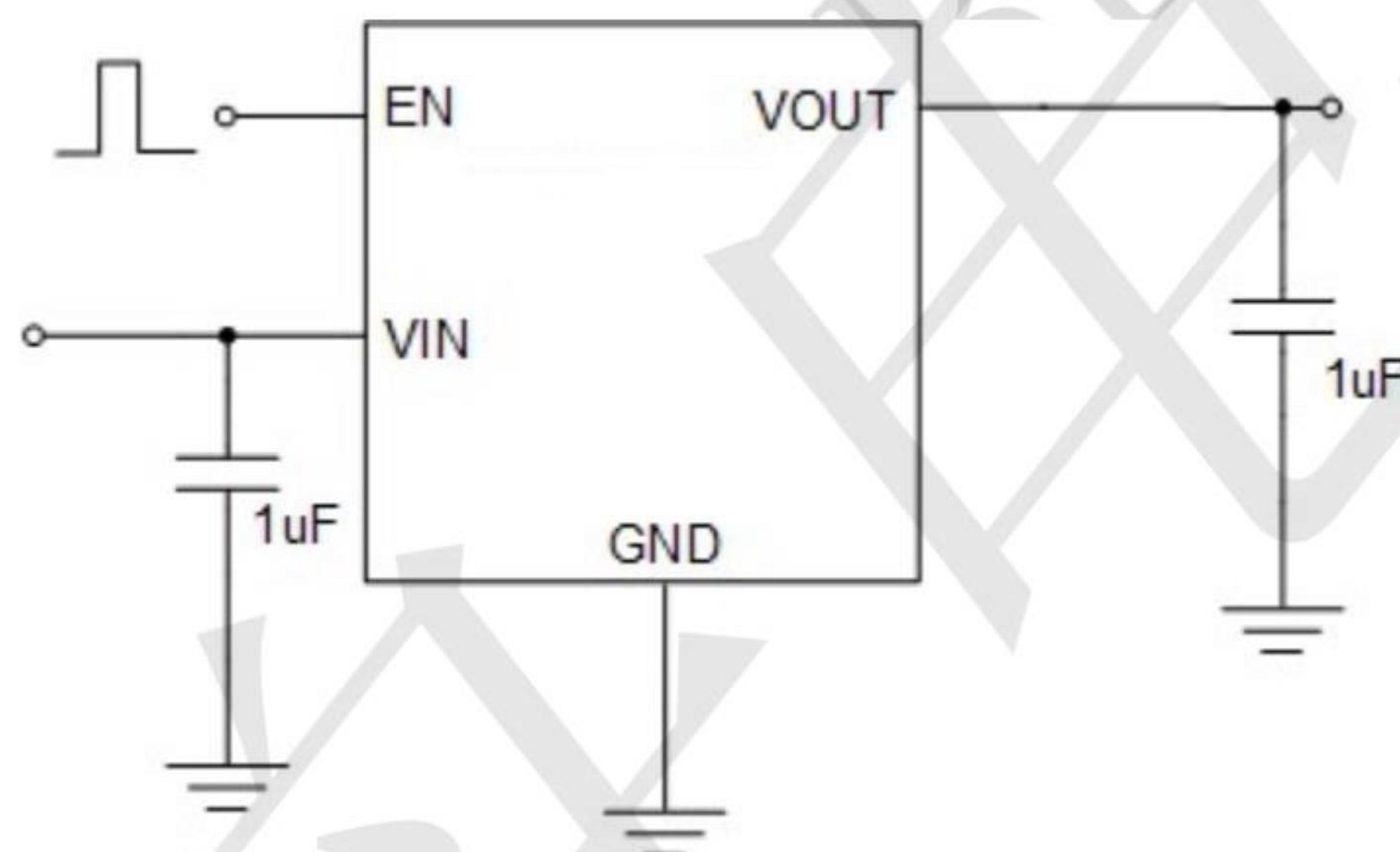

Figure 2: Application circuit of Fixed V_{OUT} LDO with enable function

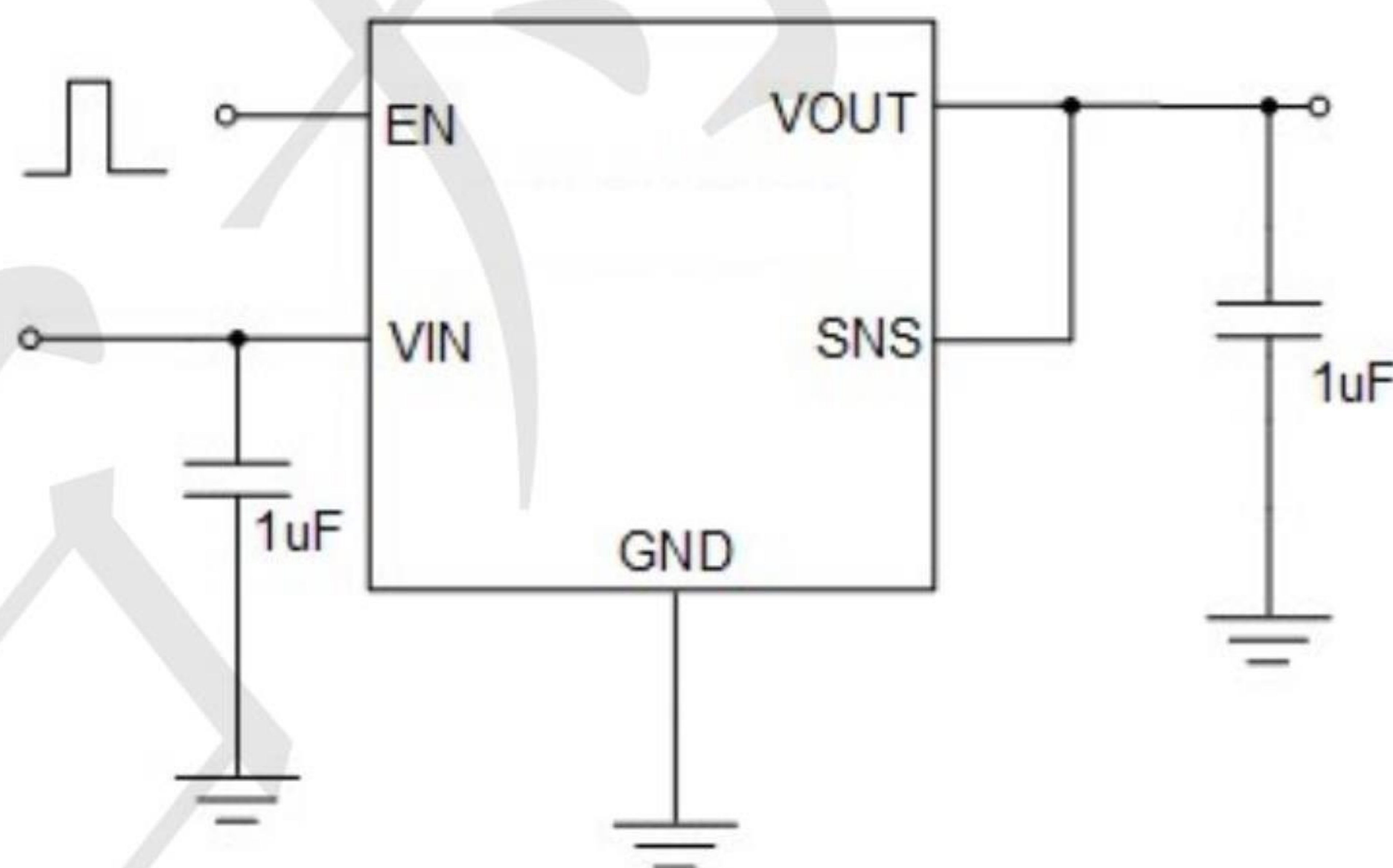
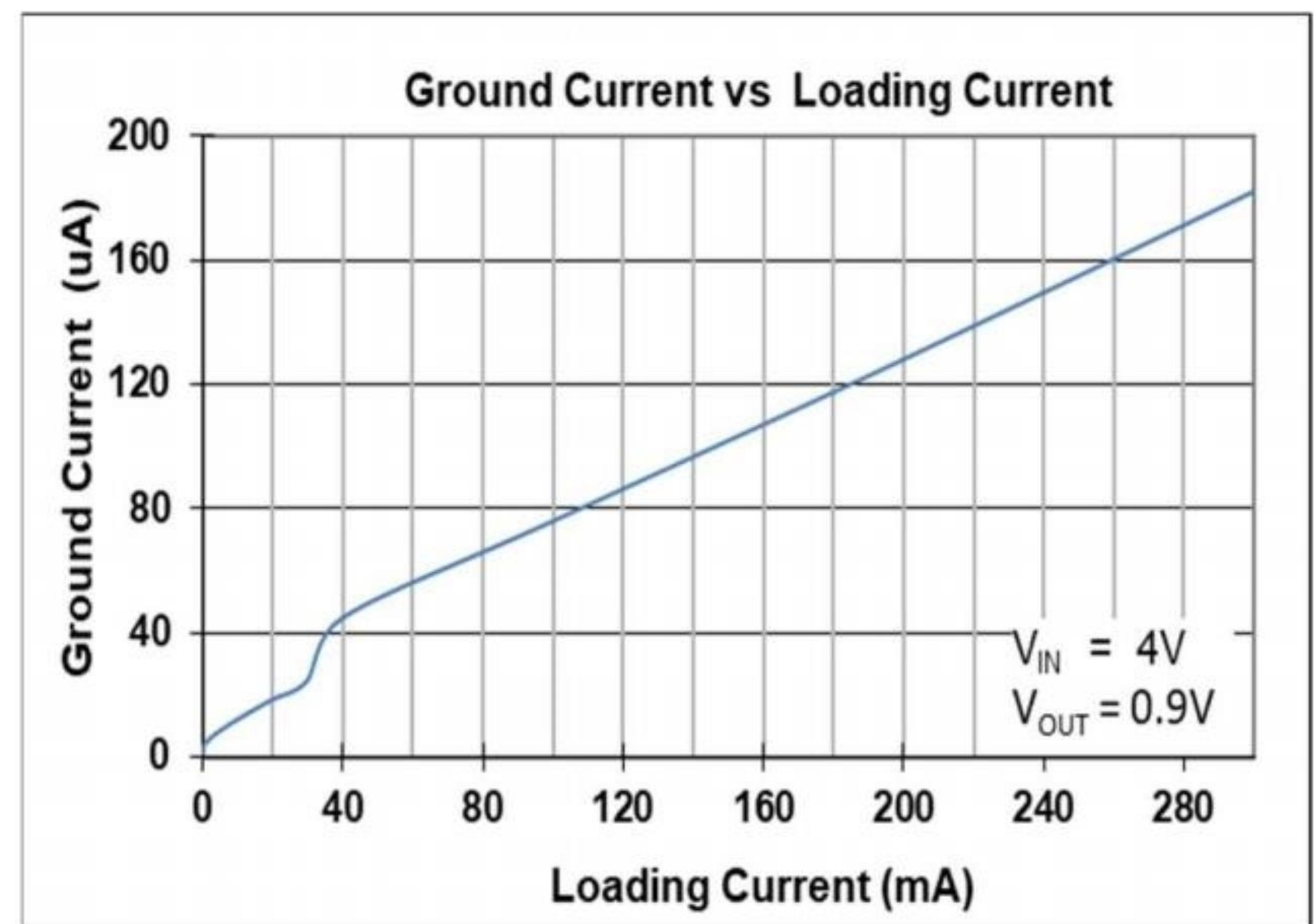
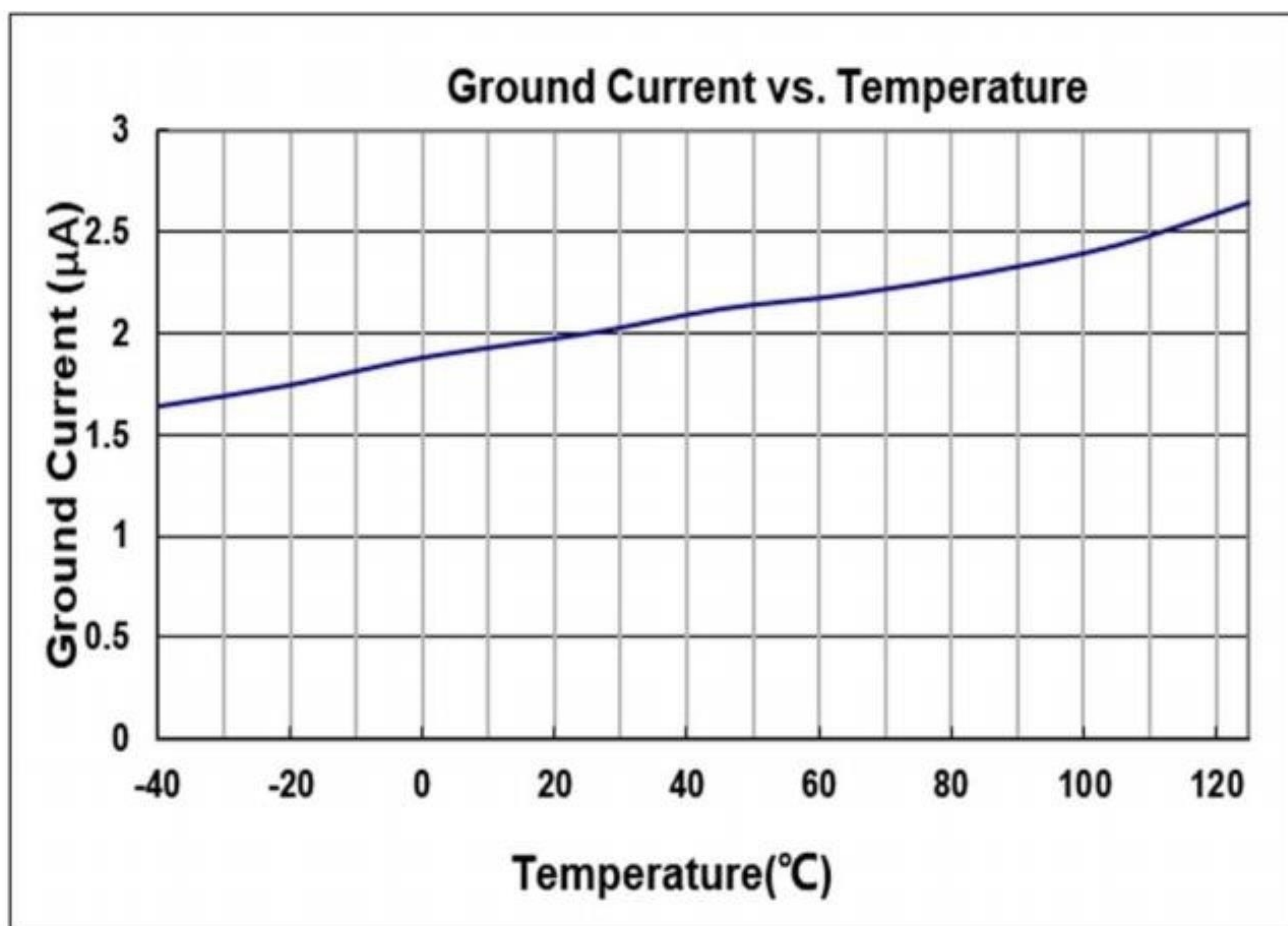
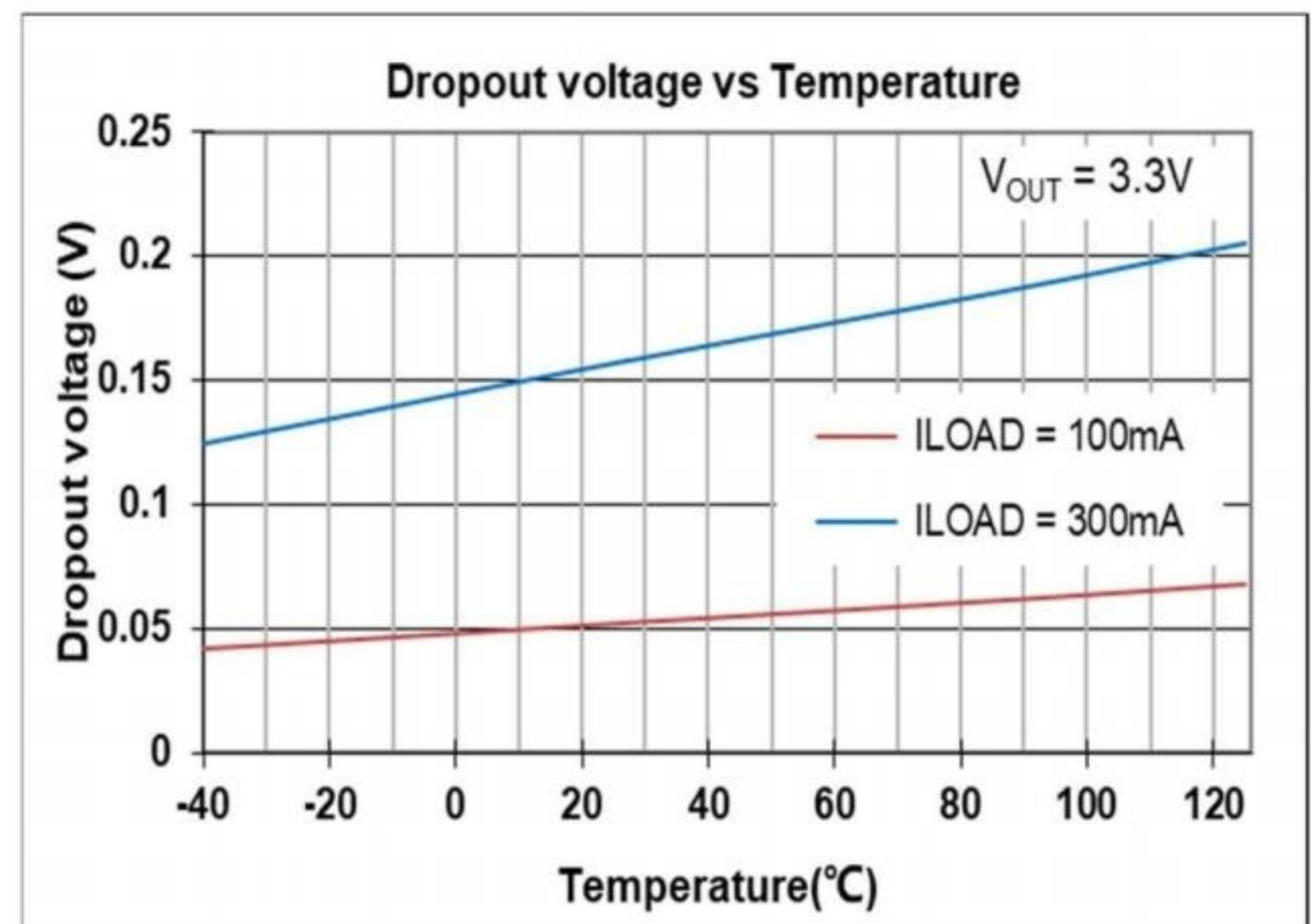
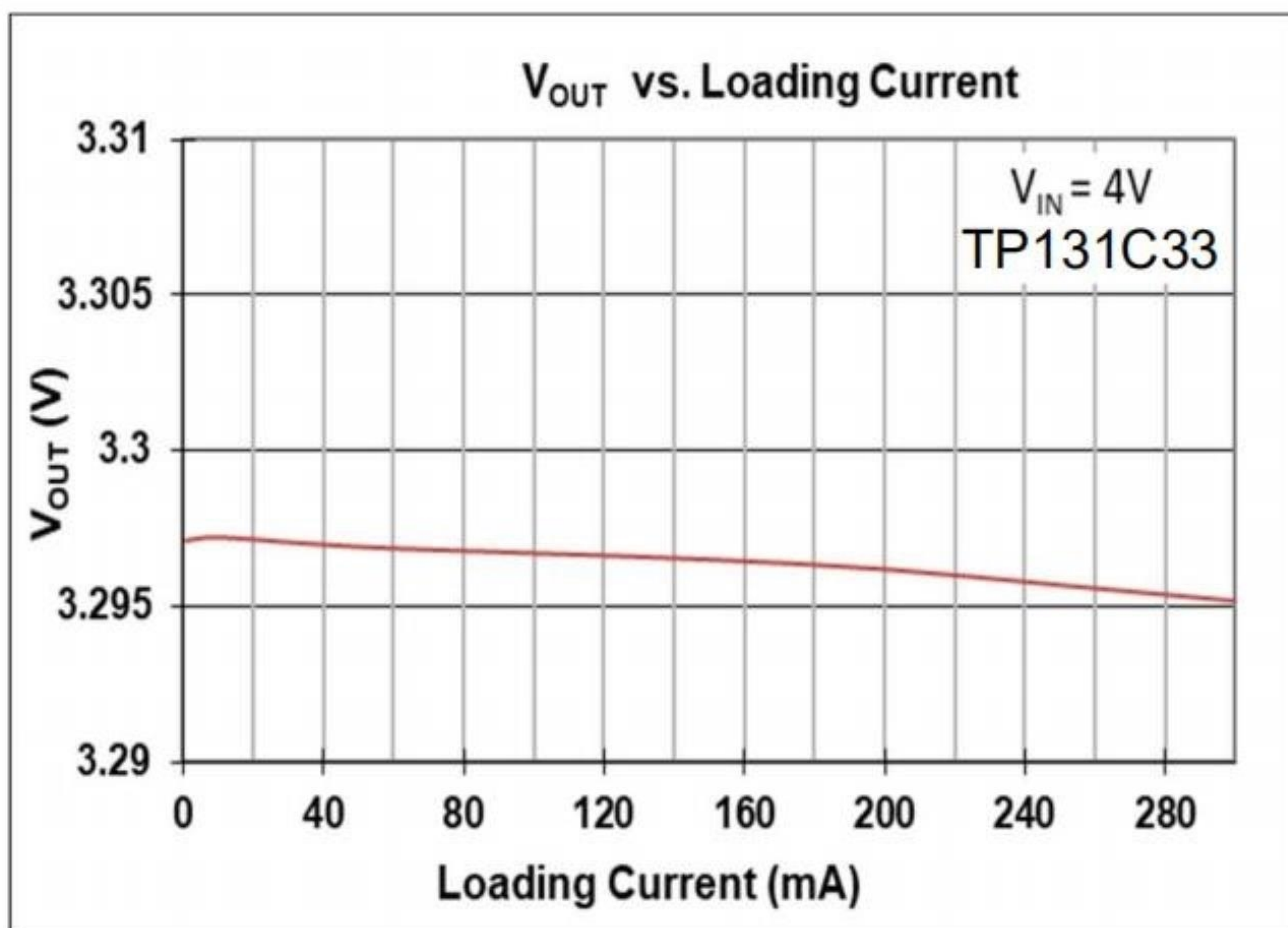
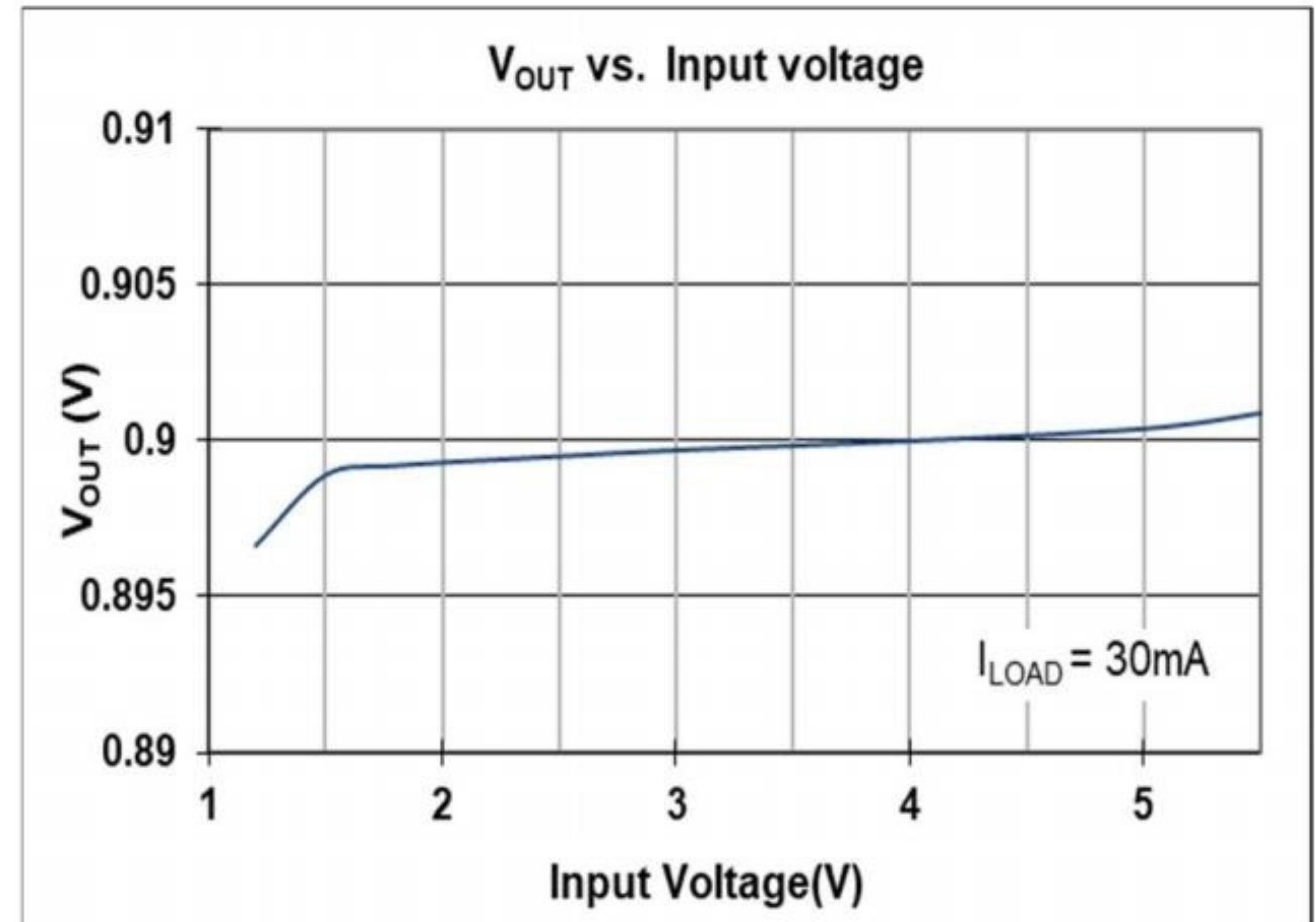
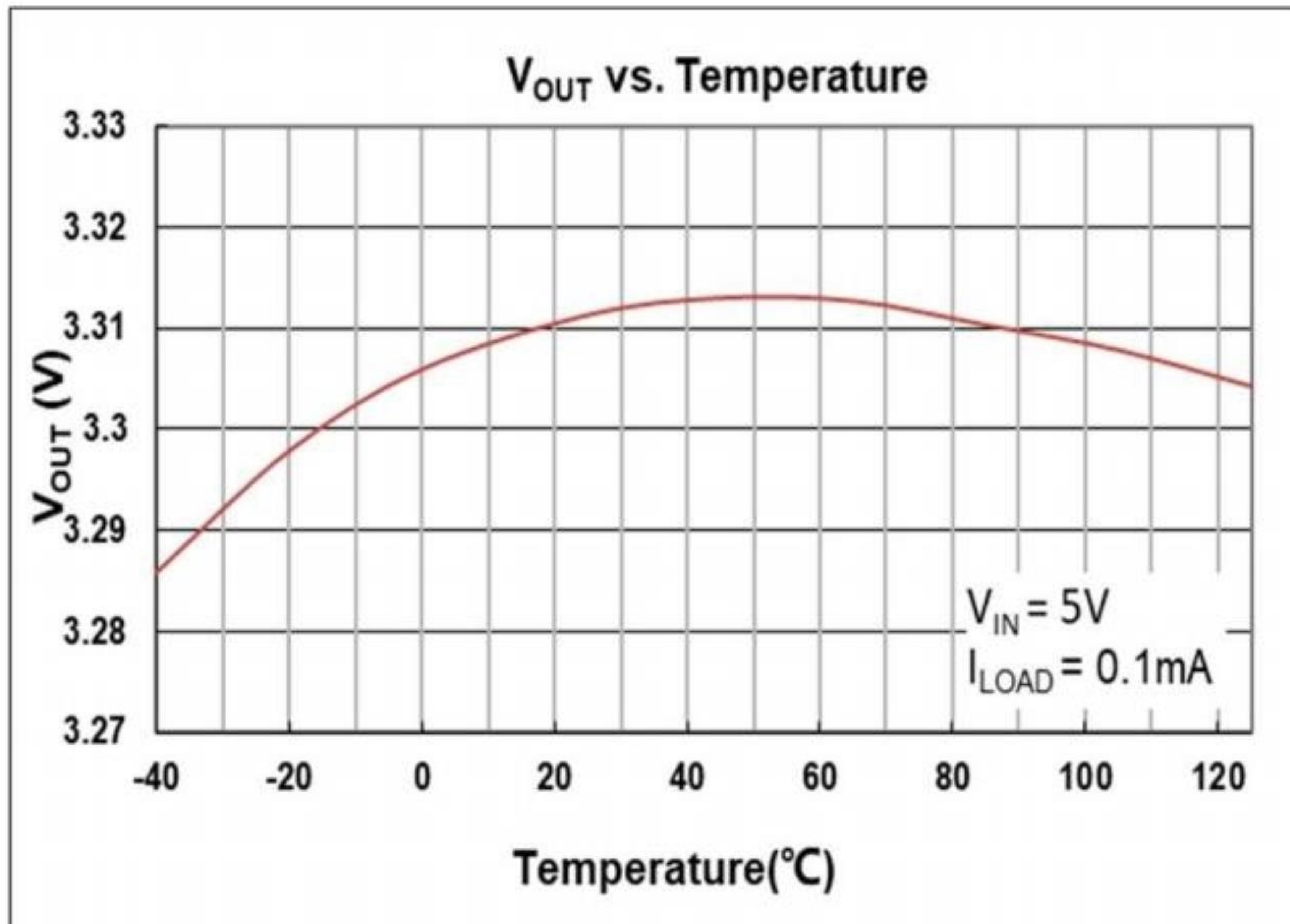
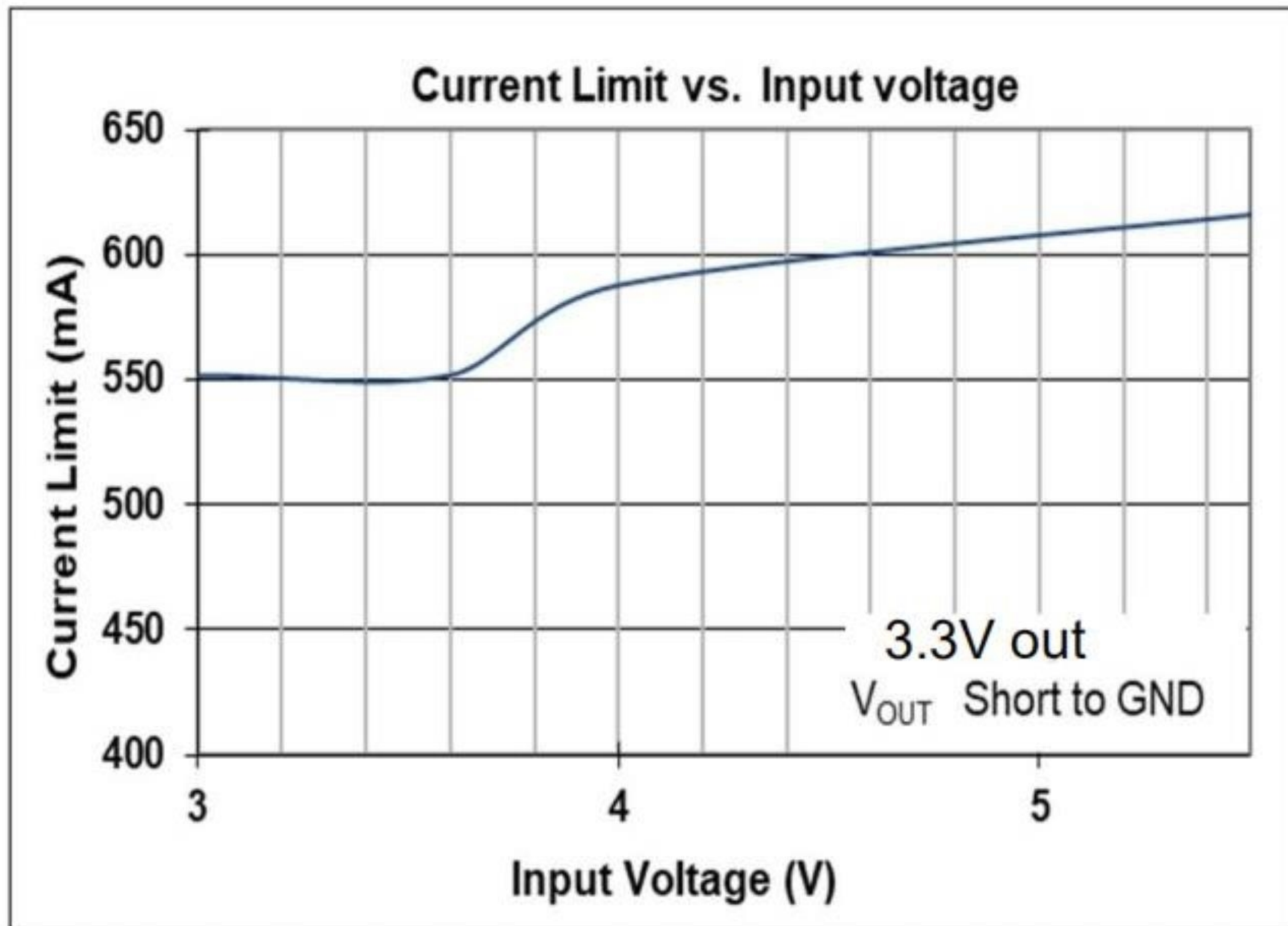
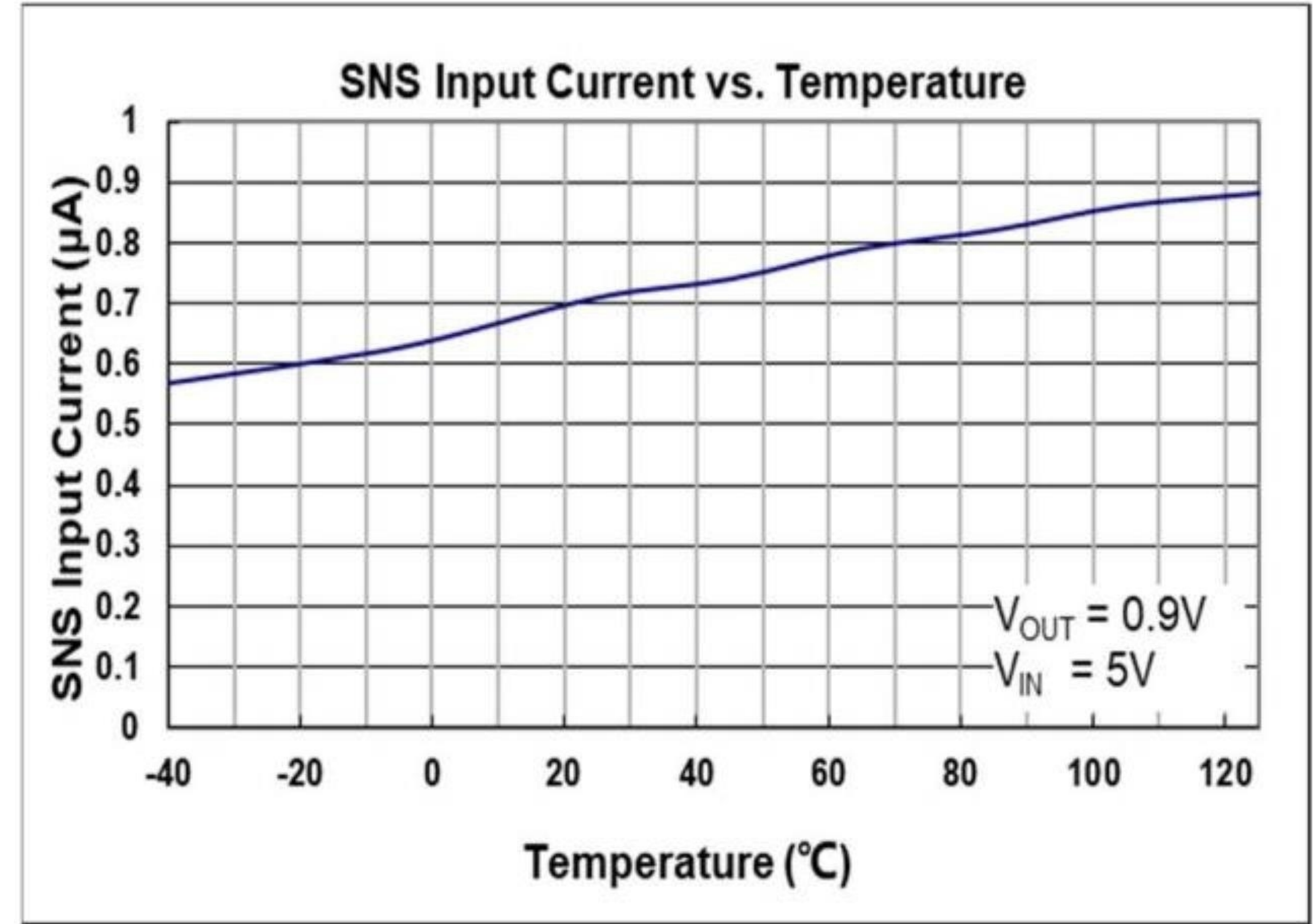
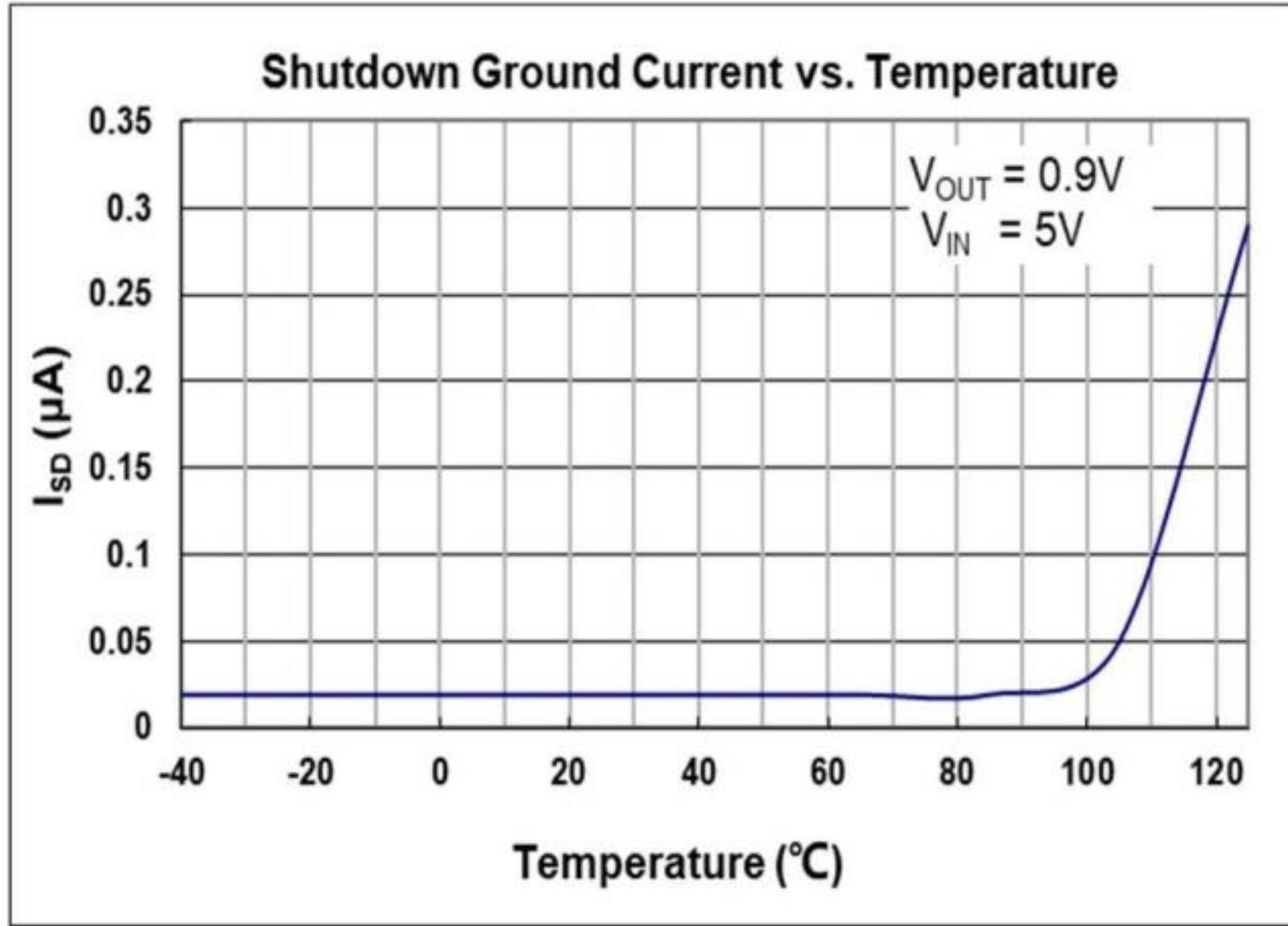
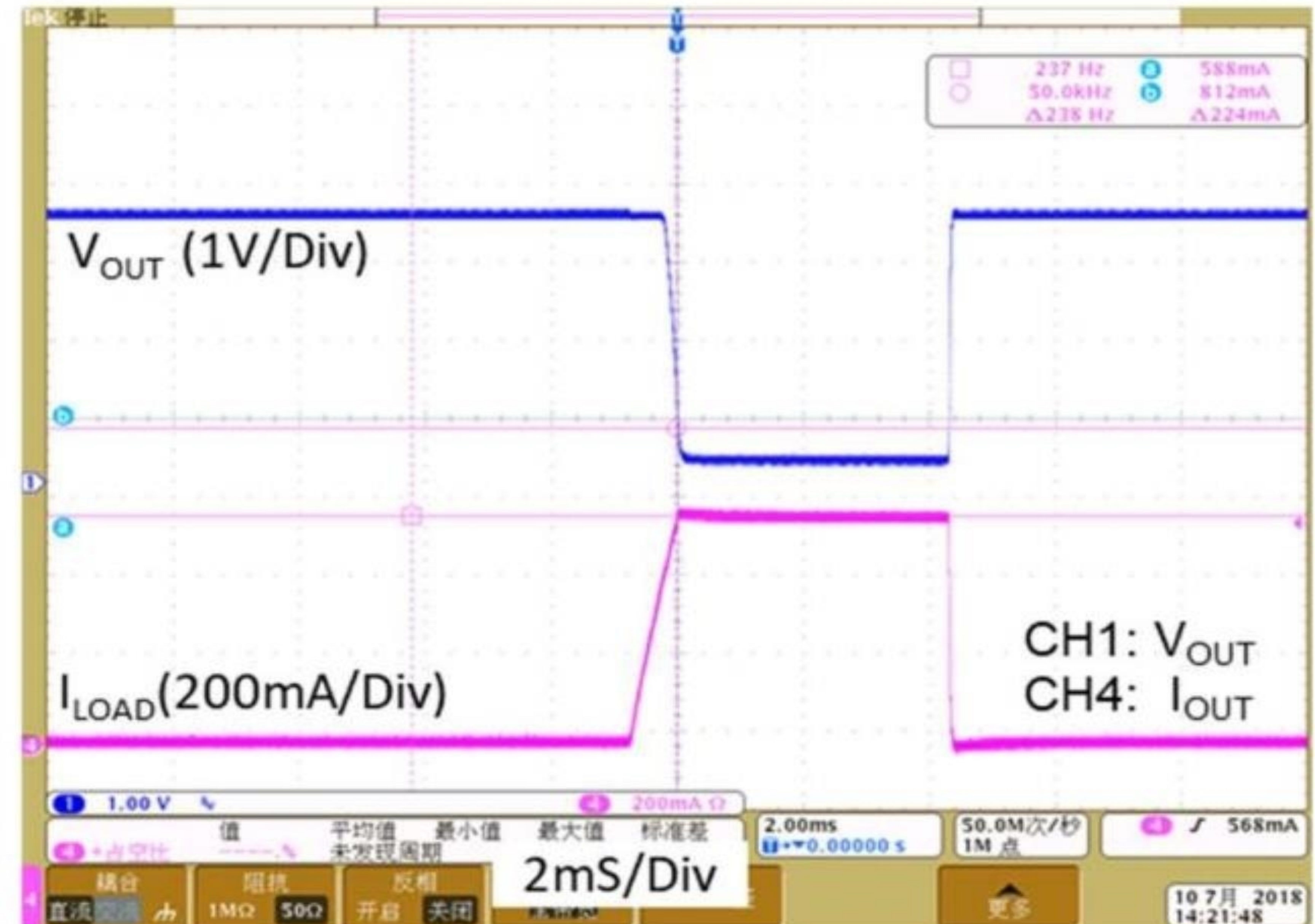

Figure 3: Application circuit of Fixed V_{OUT} LDO with enable and sense functions





Current Limit Response



Load Transient Response I

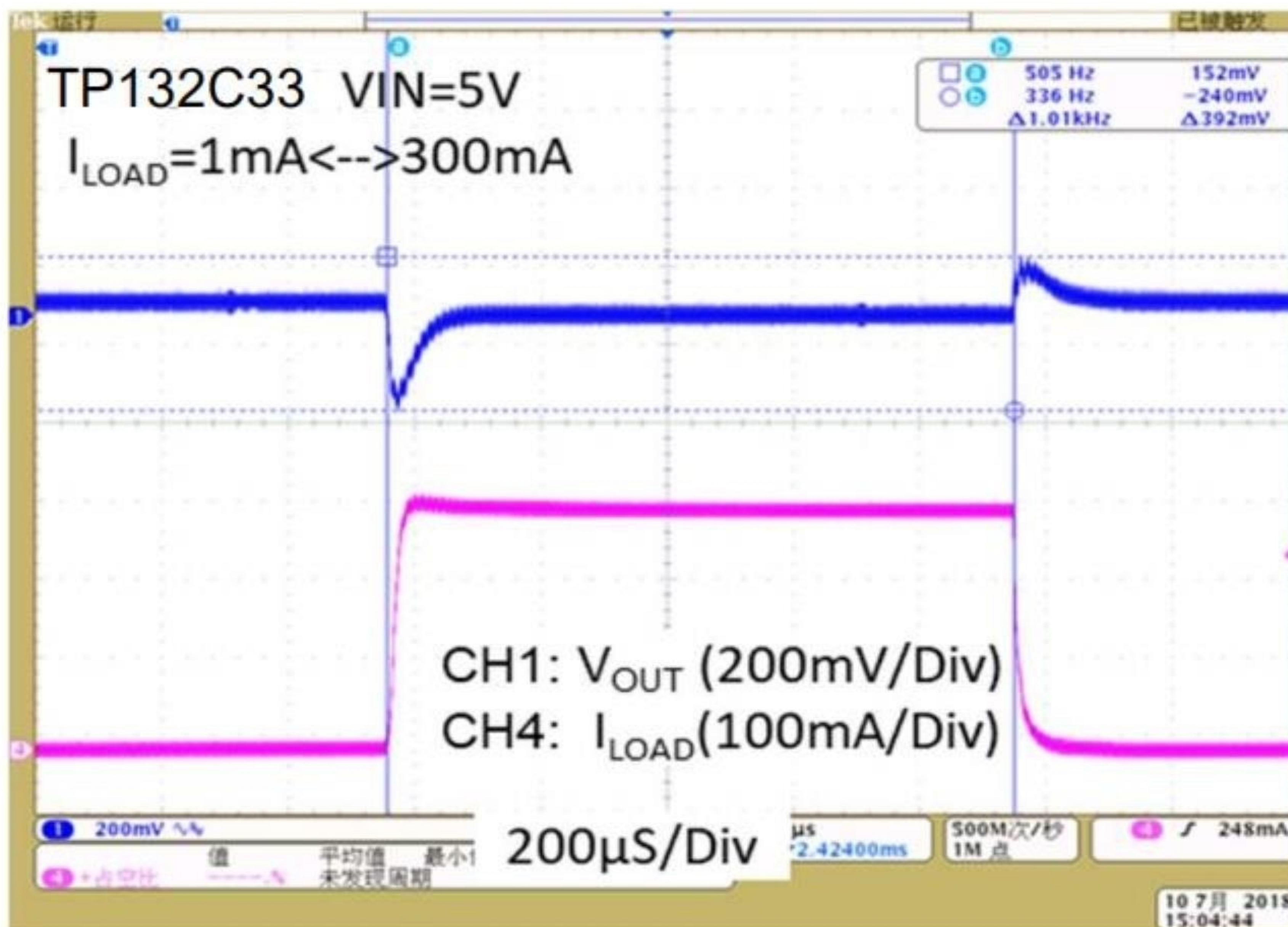

Load Transient Response II

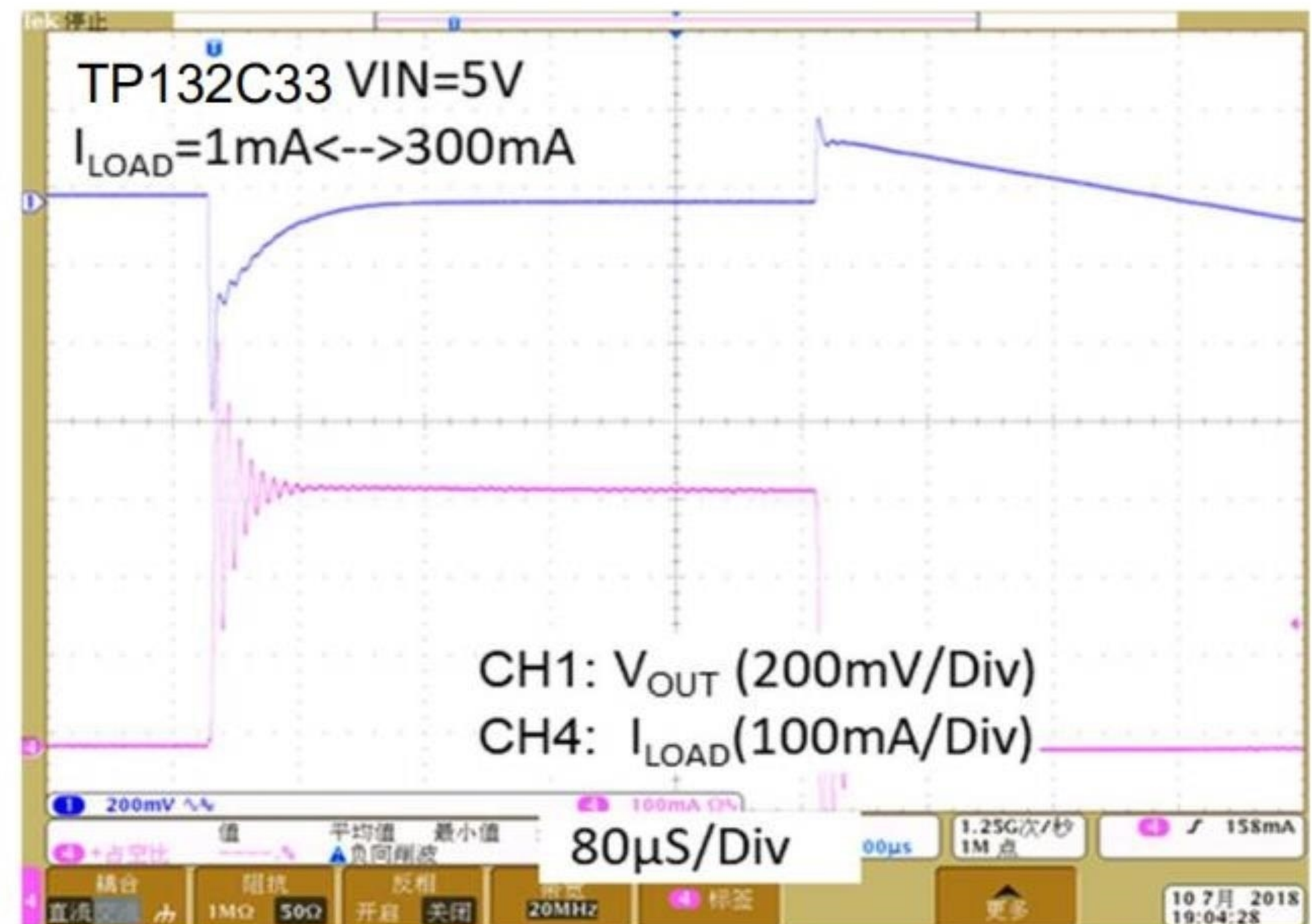

Line Transient Response

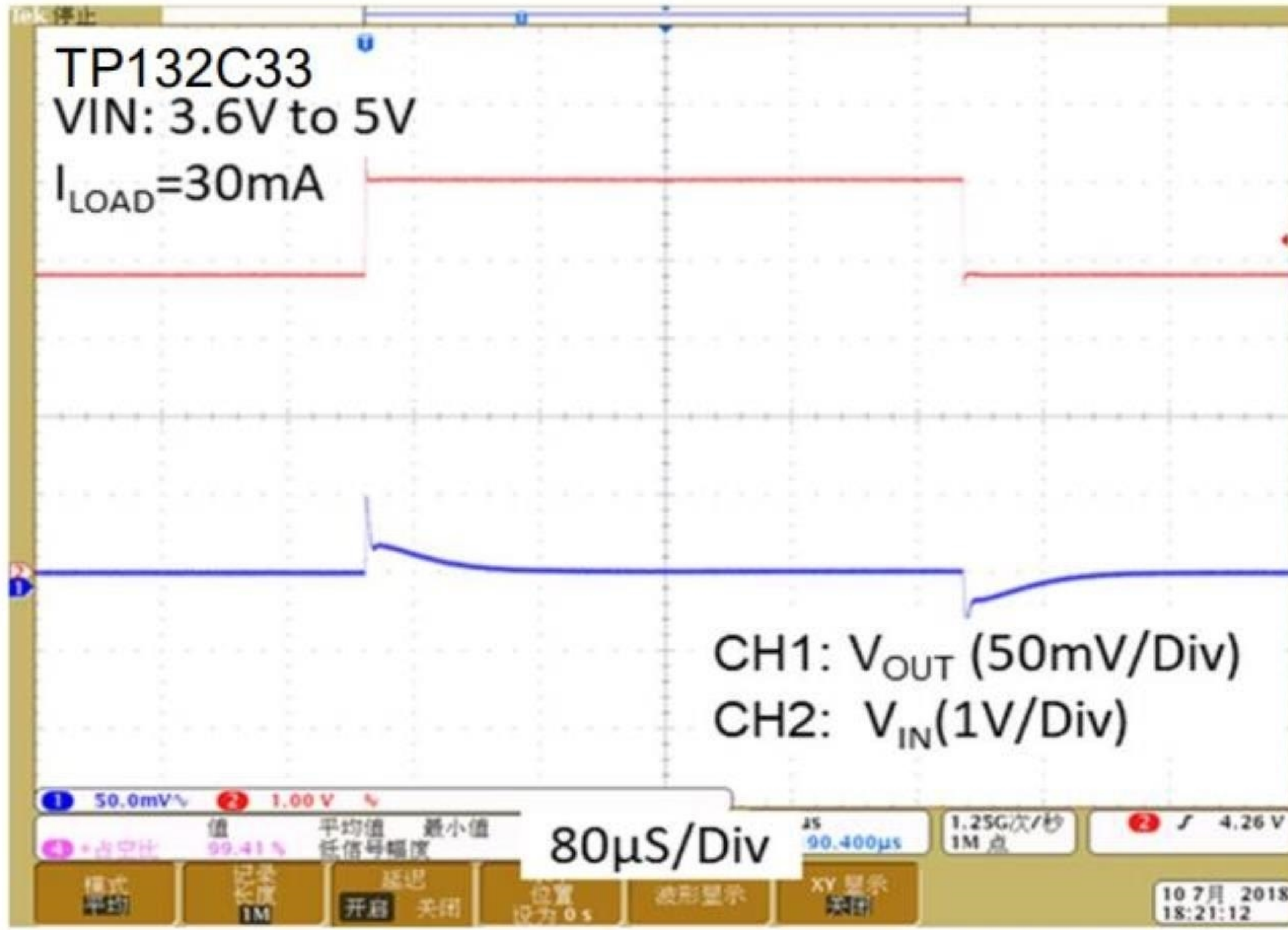

V_{OUT} Turn On/Off by EN

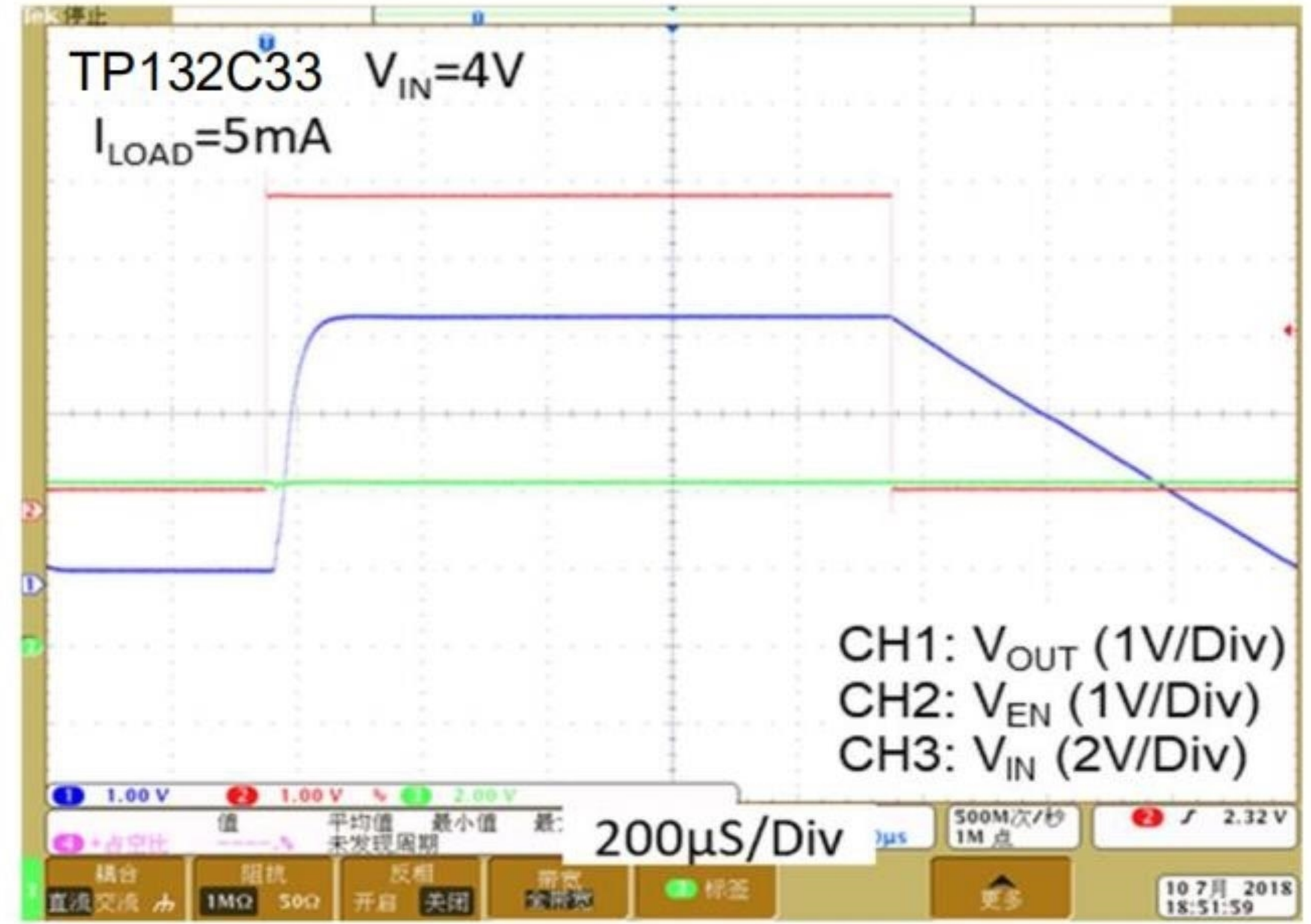

Package informantion

DFN2X2-6 Outline Dimensions

DFN-6L

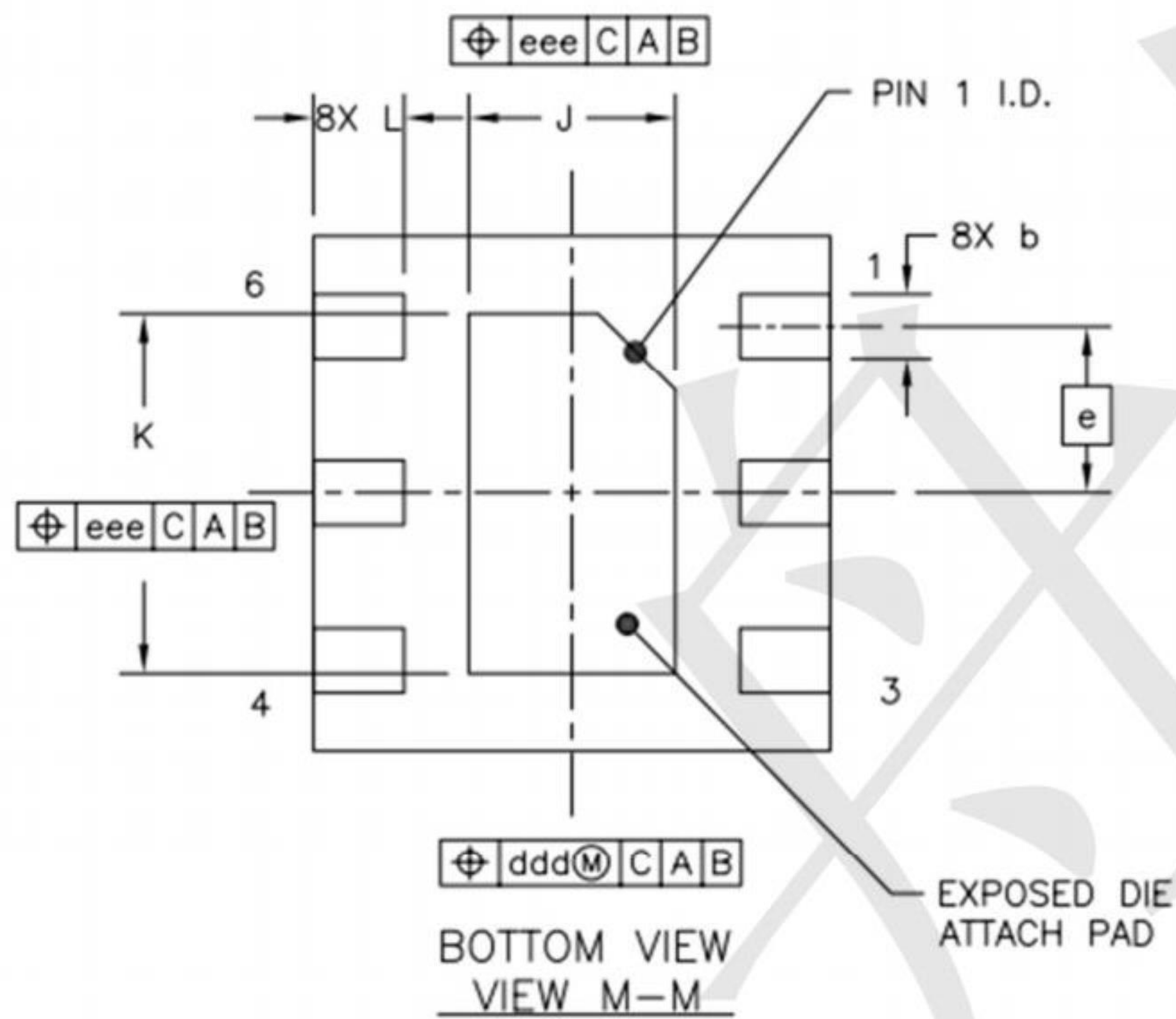
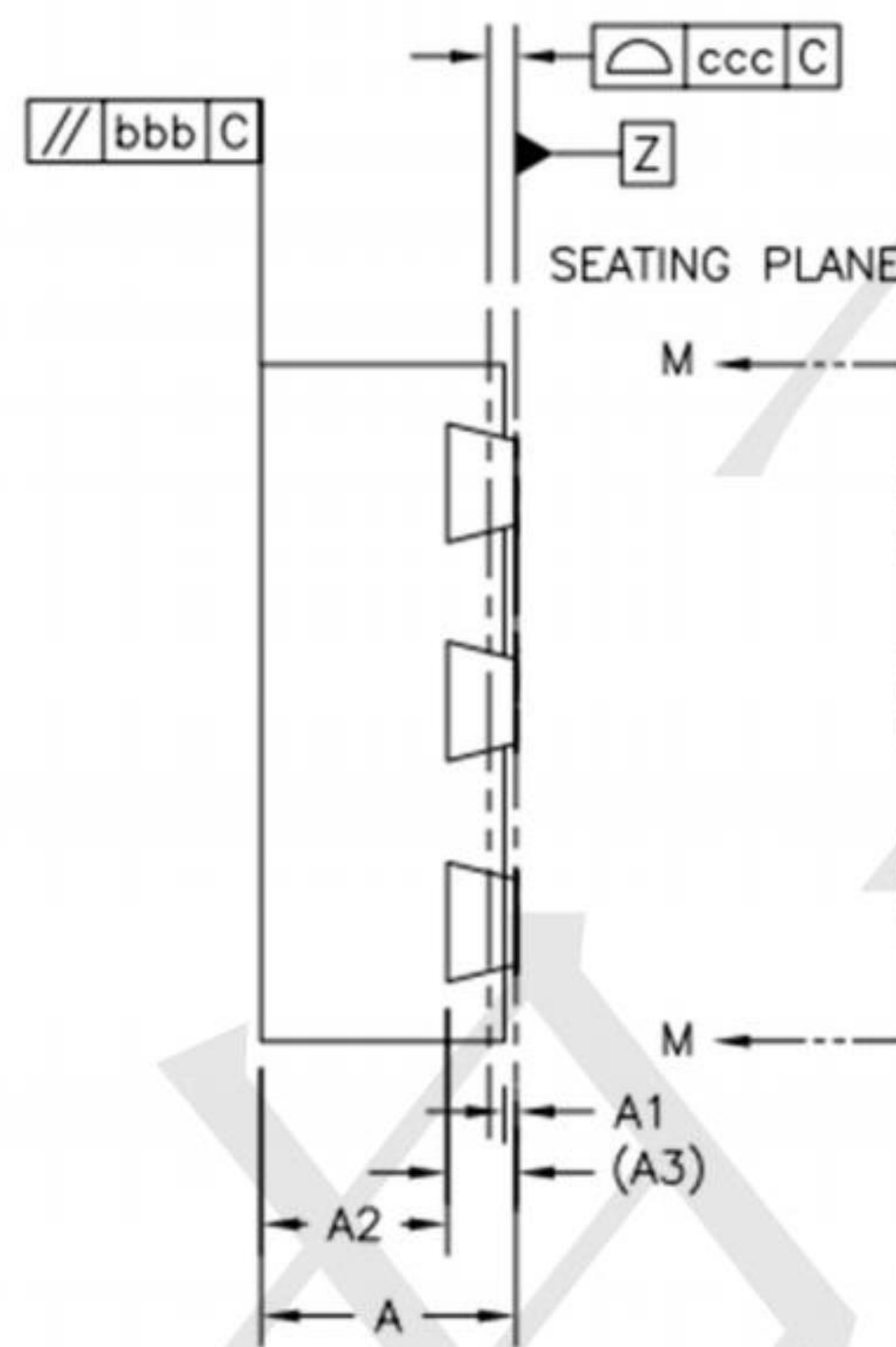
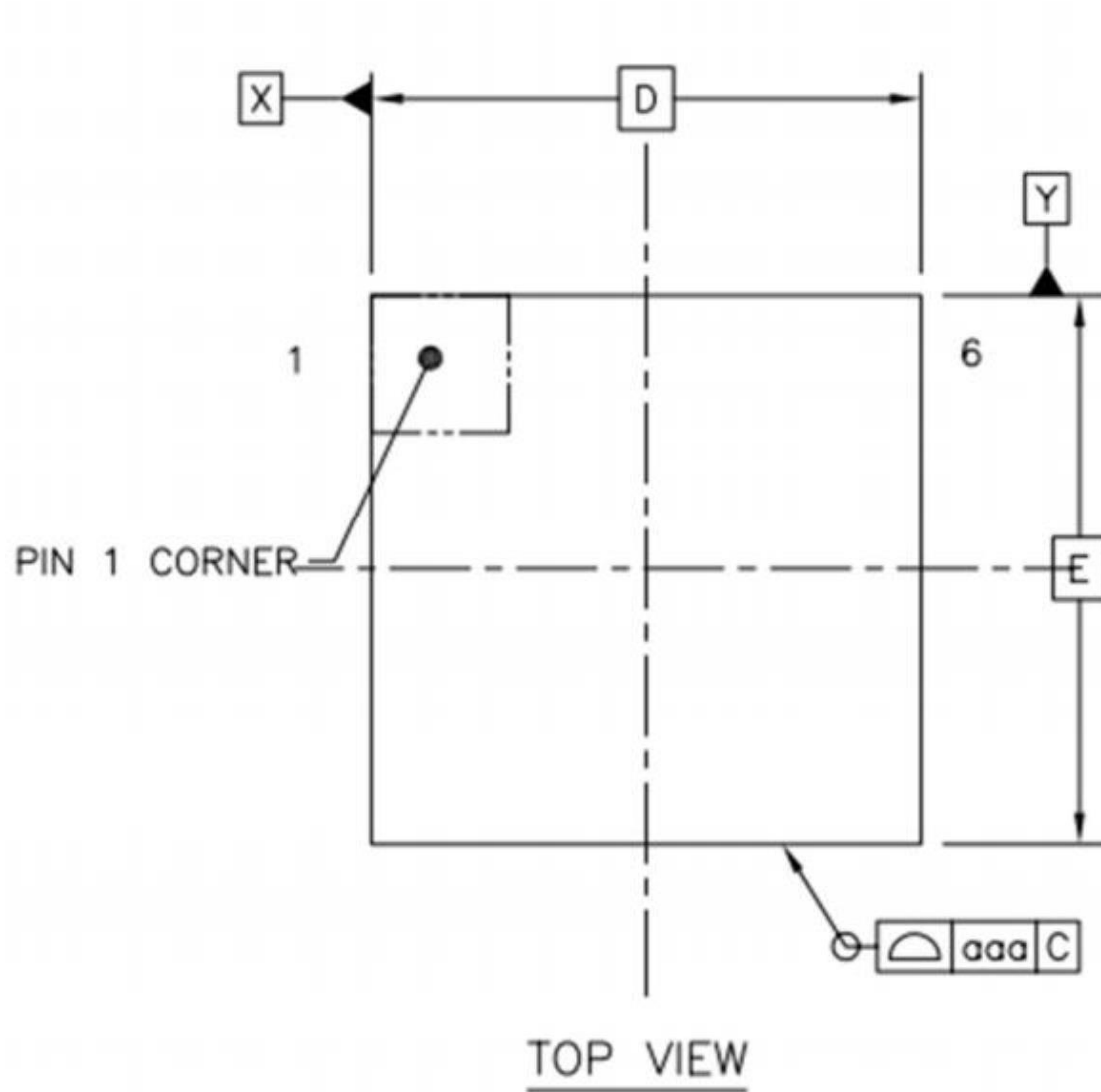

DESCRIPTION	SYMBOL	MILLIMETER			
		MIN	NOM	MAX	
TOTAL THICKNESS	A	0.7	0.75	0.8	
STAND OFF	A1	0	0.035	0.05	
MOLD THICKNESS	A2	---	0.55	0.575	
L/F THICKNESS	A3	0.203 REF			
LEAD WIDTH	b	0.20	0.25	0.30	
BODY SIZE	X	D 2 BSC			
	Y	E 2 BSC			
LEAD PITCH	e	0.65 BSC			
EP SIZE	X	J	0.75	0.8	0.85
	Y	K	1.35	1.4	1.45
LEAD LENGTH	L	0.30	0.35	0.40	
PACKAGE EDGE TOLERANCE	aaa	0.05			
MOLD FLATNESS	bbb	0.1			
COPLANARITY	ccc	0.08			
LEAD OFFSET	ddd	0.1			
EXPOSED PAD OFFSET	eee	0.1			

NOTES

1.0 COPLANARITY APPLIES TO LEADS, CORNER LEADS AND DIE ATTACH PAD.

X-ON Electronics

Largest Supplier of Electrical and Electronic Components

Click to view similar products for [Linear Voltage Regulators](#) category:

Click to view products by [TECH PUBLIC](#) manufacturer:

Other Similar products are found below :

[LV56831P-E](#) [LV5684PVD-XH](#) [MCDTSA6-2R](#) [L7815ACV-DG](#) [PQ3DZ53U](#) [LV56801P-E](#) [TLE42794G](#) [L78L05CZ/1SX](#) [L78LR05DL-MA-E](#) [636416C](#) [714954EB](#) [BA033LBSG2-TR](#) [LV5680P-E](#) [L78M15CV-DG](#) [L79M05T-E](#) [TLS202A1MBVHTSA1](#) [L78LR05D-MA-E](#) [NCV317MBTG](#) [NTE7227](#) [LV5680NPVC-XH](#) [LT1054CN8](#) [MP2018GZD-5-Z](#) [MP2018GZD-33-Z](#) [MIC5281-3.3YMM](#) [MC78L06BP-AP](#) [TA48LS05F\(TE85L,F\)](#) [TA78L12F\(TE12L,F\)](#) [TC47BR5003ECT](#) [TCR2LN12,LF\(S](#) [TCR2LN28,LF\(S](#) [TCR2LN30,LF\(S](#) [TCR3DF295,LM\(CT](#) [TCR3DF40,LM\(CT](#) [BA178M20CP-E2](#) [L78M12ABDT](#) [LM7812SX/NOPB](#) [LR645N3-G-P003](#) [LR645N3-G-P013](#) [ZXTR2005P5-13](#) [SCD7812BTG](#) [TCR3DF335,LM\(CT](#) [ZXTR2012K-13](#) [TLE42994E V33](#) [ZXTR2008K-13](#) [ZXTR2005K-13](#) [L88R05DL-E](#) [ADP3300ARTZ-2.7RL7](#) [LM120K-15/883](#) [IFX54441LDVXUMA1](#) [LM317D2T-TR](#)