

## General Description

The TP5108E is a high-performance, 500mA LDO regulator, offering extremely high PSRR and ultra-low dropout. Ideal for portable RF and wireless applications with demanding performance and space requirements.

The TP5108E is available in 5pin SOT23-5 Package .the output standards of 1.2V 1.5V 1.8V 2.5V 2.8V 3.0V 3.3V

## Features

- Quiescent Current: 80uA
- PSRR:72dB@1KHz
- < 1uA current at shutdown mode
- Output voltage accuracy: tolerance  $\pm 2\%$
- Output current:500mA(Typ.)
- SOT23-5 package

## Applications

- CDM/GSM mobile phone
- PDAs /MP3
- Audio/Video equipment

## Ordering Information

**TP5108E23E-33**

Output voltage: 33=3.3V  
50=5.0V  
28=2.8V  
30=3.0V  
XX=X.XV

23E:SOT23-5 Package

**BLOCK DIAGRAM**

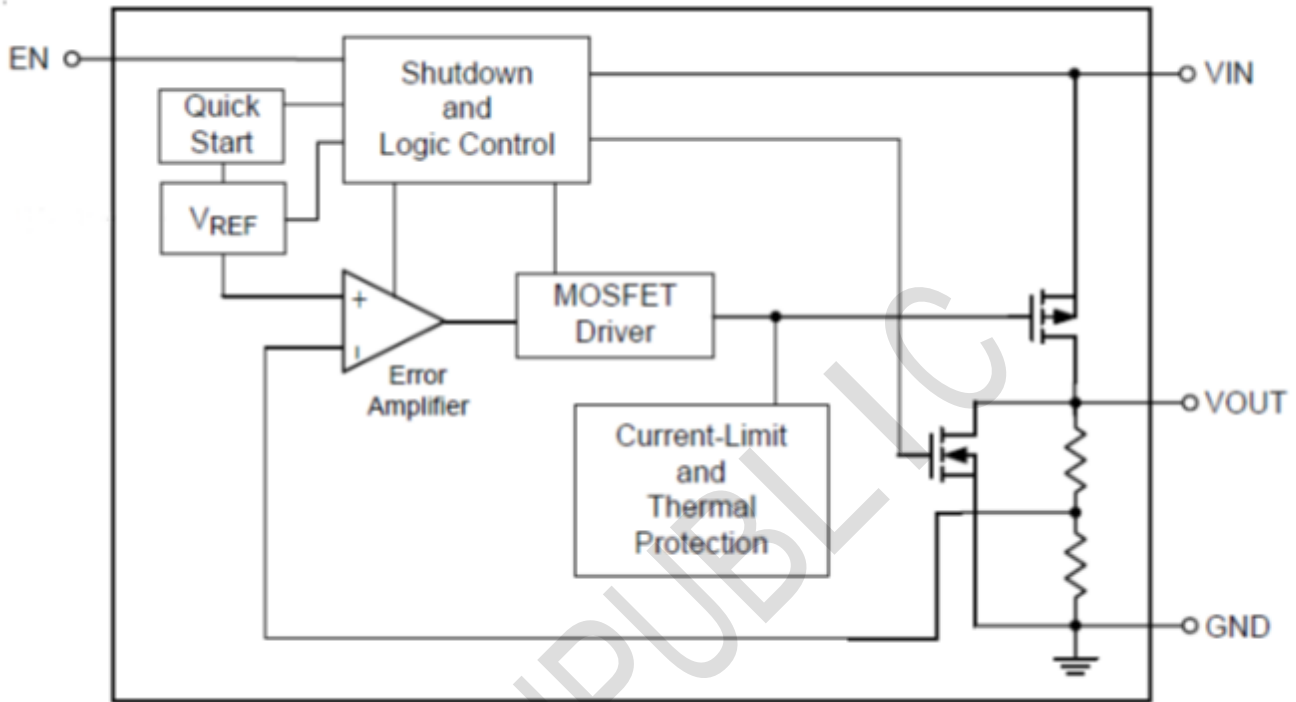

**PIN CONFIGURATION**

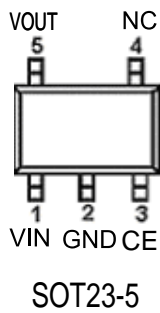

Pin Name	Function
VIN	Supply power
GND	Ground
CE	Enable pin
NC	NC
VOUT	Voltage output

**Absolute Maximum Rating** ( $T_A=25^{\circ}\text{C}$  unless otherwise noted)

Parameter	Symbol	Maximum Rating		Unit
Input Voltage	$V_{IN}$	7		V
Output Voltage	$V_{OUT}$	$V_{SS}-0.3 \sim V_{IN}+0.3$		
Output Current	$I_{out}$	600		mA
Power Dissipation	$P_D$	SOT-23-5	250	mW
Operating Ambient Temperature	$T_{opr}$	-40~+85		
Storage Temperature	$T_{stg}$	-40~+125		

**Electrical Characteristics** ( $T = 25^{\circ}\text{C}$  unless otherwise noted)

( $V_{in}=V_{out}+1V, C_{in}=C_{out}=1\mu F, T_a=25^{\circ}\text{C}$ )

PARAMETER	SYMBOL	CONDITIONS	MIN	TYP	MAX	UNITS
Output Voltage	$V_{OUT(E)}$ (Note 2)	$I_{OUT}=40\text{mA}$ , $V_{IN}=V_{out}+1V$	X 0.98	$V_{OUT(T)}$ (Note 1)	X 1.02	V
Input Voltage	$V_{IN}$				7.0	V
Max. Output Current	$I_{OUTmax}$	$V_{IN}=V_{out}+1V$		500		mA
CE Enable Voltage	$V_{CE}$	$V_{IN}=V_{out}+1V$		1.1		V
Load Regulation	$\Delta V_{OUT}$	$V_{IN}=V_{out}+1V$ , $1\text{mA} \leq I_{OUT} \leq 100\text{mA}$		50		mV
Dropout Voltage (Note 3)	$V_{dif1}$	$I_{OUT} = 100\text{mA}$		100		mV
	$V_{dif2}$	$I_{OUT} = 200\text{mA}$		300		mV
Supply Current	$I_{SS}$	$V_{IN}=V_{out}+1V$		80		$\mu\text{A}$
Standby Current	$I_{CEL}$	$V_{ce}=0V$		1		$\mu\text{A}$
Line Regulation	$\frac{\Delta V_{OUT}}{\Delta V_{IN} \cdot V_{OUT}}$	$I_{OUT} = 40\text{mA}$ $V_{out}+1V \leq V_{IN} \leq 8V$		0.03		%/V
Output Noise	en	$I_{OUT} = 40\text{mA}$ , 300Hz~50kHz		50		$\mu\text{Vrms}$
Ripple Rejection Rate	PSRR	$V_{in} = [V_{out}+1]V$ +1Vp-pAC $I_{OUT} = 40\text{mA}, f=1\text{kHz}$		70		dB

**TYPICAL APPLICATION**

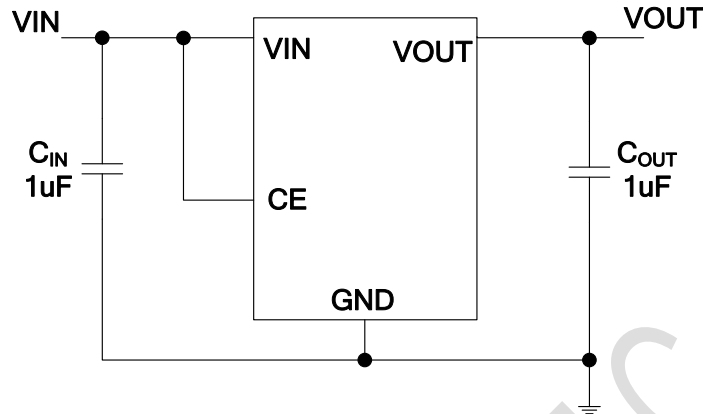

TECHPUBLIC

**Package informantion**

SOT23-5

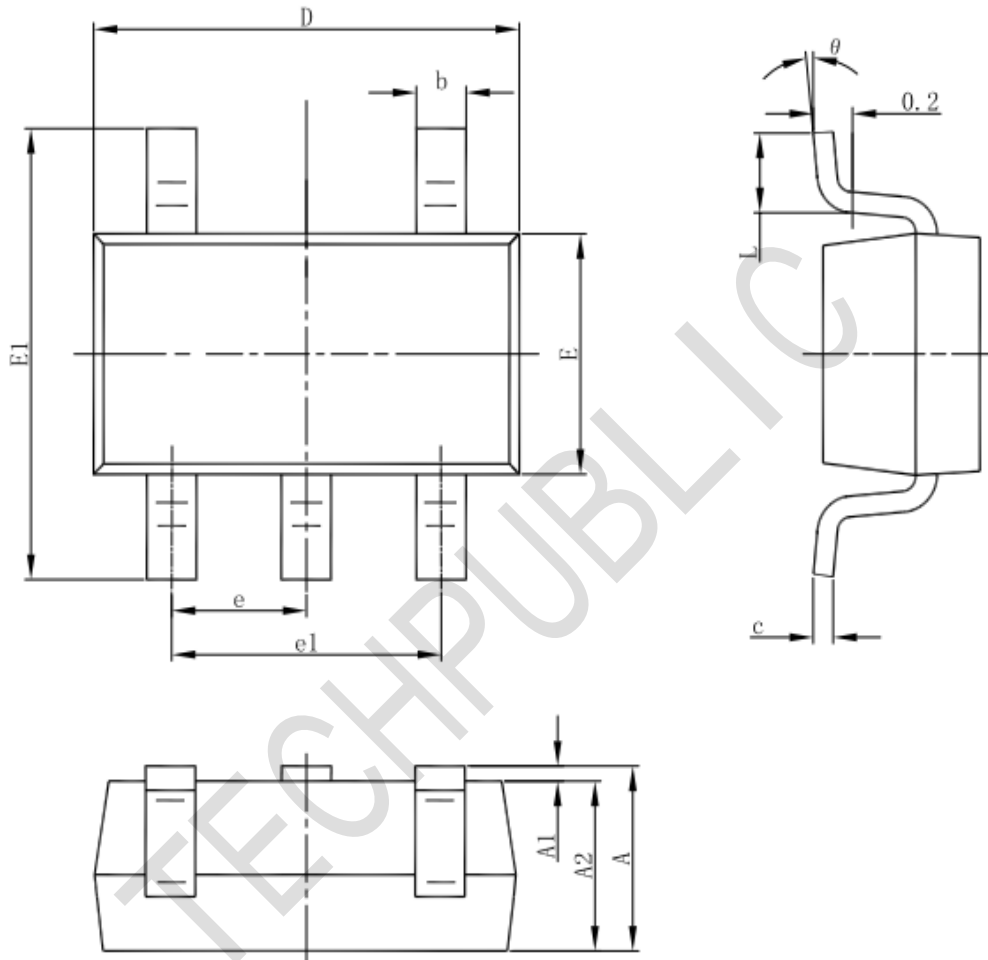

Symbol	Dimensions In Millimeters		Dimensions In Inches	
	Min	Max	Min	Max
A	1.050	1.250	0.041	0.049
A1	0.000	0.100	0.000	0.004
A2	1.050	1.150	0.041	0.045
b	0.300	0.500	0.012	0.020
c	0.100	0.200	0.004	0.008
D	2.820	3.020	0.111	0.119
E	1.500	1.700	0.059	0.067
E1	2.650	2.950	0.104	0.116
e	0.950(BSC)		0.037(BSC)	
e1	1.800	2.000	0.071	0.079
L	0.300	0.600	0.012	0.024
θ	0°	8°	0°	8°

## X-ON Electronics

Largest Supplier of Electrical and Electronic Components

*Click to view similar products for [LDO Voltage Regulators](#) category:*

*Click to view products by [TECH PUBLIC](#) manufacturer:*

Other Similar products are found below :

[M38D29FFHP#U1](#) [702103A](#) [717726C](#) [742457H](#) [MP20051DN-LF-Z](#) [R5F111PGGFB#30](#) [AP7363-SP-13](#) [NCP103AMX285TCG](#)  
[NCV8664CST33T3G](#) [NCV8752AMX28TCG](#) [L9454](#) [AP7362-HA-7](#) [LX13043CLD](#) [TCR3DF185,LM\(CT](#) [TCR3DF24,LM\(CT](#)  
[TCR3DF285,LM\(CT](#) [TCR3DF31,LM\(CT](#) [TCR3DF45,LM\(CT](#) [TLF4949EJ](#) [L9708](#) [L970813TR](#) [030014BB](#) [059985X](#) [EAN61387601](#)  
[EAN61573601](#) [NCP121AMX173TCG](#) [NCP4687DH15T1G](#) [NCV8703MX30TCG](#) [701326R](#) [702087BB](#) [755078E](#) [TCR2EN28,LF\(S](#)  
[LM1117DT-1.8/NO](#) [LT1086CM#TRPBF](#) [AZ1085S2-1.5TRE1](#) [MAX15101EWL+T](#) [NCV8170AXV250T2G](#) [SCD337BTG](#)  
[TCR3DF27,LM\(CT](#) [TCR3DF19,LM\(CT](#) [TCR3DF125,LM\(CT](#) [TCR2EN18,LF\(S](#) [MAX15103EWL+T](#) [TS2937CZ-5.0 C0](#) [MAX8878EUK30-](#)  
[T](#) [MAX663CPA](#) [NCV4269CPD50R2G](#) [NCV8716MT30TBG](#) [AZ1117IH-1.2TRG1](#) [MP2013GQ-P](#)