

## Features

- \* 350W peak pulse power (8/20 $\mu$ s)
- \* Ultra low capacitance: 1.0 pF typical
- \* Ultra low leakage: nA level
- \* Low operating :  
3.3V ,5V,8V,12V,15V,18V,24V,30V
- \* Low clamping voltage
- \* Protects one power line or data line
- \* Complies with following standards:
- \* – IEC 61000-4-2 (ESD) immunity test  
Air discharge:  $\pm 30$ kV  
Contact discharge:  $\pm 30$ kV
- \* – IEC61000-4-4 (EFT) 40A (5/50ns)
- \* RoHS Compliant

## Mechanical Characteristics

- \* Package: SOD-323
- \* Lead Finish: Matte Tin
- \* Case Material: “Green” Molding Compound.
- \* UL Flammability Classification Rating 94V-0
- \* Moisture Sensitivity: Level 3 per J-STD-020
- \* Terminal Connections: See Diagram Below



## Applications

- \* USB Ports
- \* Smart Phones
- \* Wireless Systems
- \* Ethernet 10/100/1000 Base T

## Ordering Information

Part Number	Qty per Reel	Reel Size
TPGC03C-TPGC30C	3000	7"

## Dimensions and Pin Configuration

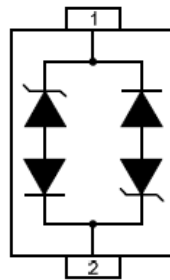

**Absolute Maximum Ratings ( $T_A=25^\circ\text{C}$  unless otherwise specified)**

Parameter	Symbol	Value	Unit
Peak Pulse Power (8/20 $\mu\text{s}$ )	Ppk	350	W
Peak Pulse Current (8/20 $\mu\text{s}$ )	IPP	22-6	A
ESD per IEC 61000-4-2 (Air)	VESD	$\pm 30$	kV
ESD per IEC 61000-4-2 (Contact)		$\pm 30$	
Operating Temperature Range	TJ	-40 to +85	$^\circ\text{C}$
Storage Temperature Range	Tstg	-55 to +150	$^\circ\text{C}$

**Electrical Characteristics ( $T_A=25^\circ\text{C}$  unless otherwise specified)**

**TPGC03C**

Parameter	Symbol	Test Condition	Min	Typ	Max	Unit
Reverse Working Voltage	$V_{RWM}$				3.3	V
Breakdown Voltage	$V_{BR}$	$I_T = 1\text{mA}$	4		6	V
Reverse Leakage Current	$I_R$	$V_{RWM} = 3.3\text{ V}$			0.2	$\mu\text{A}$
Clamping Voltage	$V_C$	$I_{PP} = 1\text{A}$ (8 x 20 $\mu\text{s}$ pulse)			5	V
Clamping Voltage	$V_C$	$I_{PP} = 22\text{A}$ (8 x 20 $\mu\text{s}$ pulse)			16	V
Junction Capacitance	$C_J$	$V_R = 0\text{V}$ , $f = 1\text{MHz}$		1		pF

**TPGC05C**

Parameter	Symbol	Test Condition	Min	Typ	Max	Unit
Reverse Working Voltage	$V_{RWM}$				5.0	V
Breakdown Voltage	$V_{BR}$	$I_T = 1\text{mA}$	6		8	V
Reverse Leakage Current	$I_R$	$V_{RWM} = 5.0\text{ V}$			0.2	$\mu\text{A}$
Clamping Voltage	$V_C$	$I_{PP} = 1\text{A}$ (8 x 20 $\mu\text{s}$ pulse)			9	V
Clamping Voltage	$V_C$	$I_{PP} = 18\text{A}$ (8 x 20 $\mu\text{s}$ pulse)			19	V
Junction Capacitance	$C_J$	$V_R = 0\text{V}$ , $f = 1\text{MHz}$		1		pF

**Electrical Characteristics ( $T_A=25^\circ\text{C}$  unless otherwise specified)**

**TPGC08C**

Parameter	Symbol	Test Condition	Min	Typ	Max	Unit
Reverse Working Voltage	$V_{RWM}$				8.0	V
Breakdown Voltage	$V_{BR}$	$I_T = 1\text{mA}$	8.5			V
Reverse Leakage Current	$I_R$	$V_{RWM} = 8\text{V}$			0.2	$\mu\text{A}$
Clamping Voltage	$V_C$	$I_{PP} = 1\text{A}$ (8 x 20 $\mu\text{s}$ pulse)			13	V
Clamping Voltage	$V_C$	$I_{PP} = 18\text{A}$ (8 x 20 $\mu\text{s}$ pulse)			19.5	V
Junction Capacitance	$C_J$	$V_R = 0\text{V}$ , $f = 1\text{MHz}$		1		pF

**TPGC12C**

Parameter	Symbol	Test Condition	Min	Typ	Max	Unit
Reverse Working Voltage	$V_{RWM}$				12.0	V
Breakdown Voltage	$V_{BR}$	$I_T = 1\text{mA}$	13.3			V
Reverse Leakage Current	$I_R$	$V_{RWM} = 12\text{V}$			0.2	$\mu\text{A}$
Clamping Voltage	$V_C$	$I_{PP} = 1\text{A}$ (8 x 20 $\mu\text{s}$ pulse)			18	V
Clamping Voltage	$V_C$	$I_{PP} = 12\text{A}$ (8 x 20 $\mu\text{s}$ pulse)			29	V
Junction Capacitance	$C_J$	$V_R = 0\text{V}$ , $f = 1\text{MHz}$		1		pF

**TPGC15C**

Parameter	Symbol	Test Condition	Min	Typ	Max	Unit
Reverse Working Voltage	$V_{RWM}$				15.0	V
Breakdown Voltage	$V_{BR}$	$I_T = 1\text{mA}$	16.7			V
Reverse Leakage Current	$I_R$	$V_{RWM} = 15\text{V}$			0.2	$\mu\text{A}$
Clamping Voltage	$V_C$	$I_{PP} = 1\text{A}$ (8 x 20 $\mu\text{s}$ pulse)			22	V
Clamping Voltage	$V_C$	$I_{PP} = 10\text{A}$ (8 x 20 $\mu\text{s}$ pulse)			32	V
Junction Capacitance	$C_J$	$V_R = 0\text{V}$ , $f = 1\text{MHz}$		1		pF

**Electrical Characteristics ( $T_A=25^\circ\text{C}$  unless otherwise specified)**

**TPGC18C**

Parameter	Symbol	Test Condition	Min	Typ	Max	Unit
Reverse Working Voltage	$V_{RWM}$				18.0	V
Breakdown Voltage	$V_{BR}$	$I_T = 1\text{mA}$	20			V
Reverse Leakage Current	$I_R$	$V_{RWM} = 18\text{V}$			0.2	$\mu\text{A}$
Clamping Voltage	$V_C$	$I_{PP} = 1\text{A}$ (8 x 20 $\mu\text{s}$ pulse)			26	V
Clamping Voltage	$V_C$	$I_{PP} = 10\text{A}$ (8 x 20 $\mu\text{s}$ pulse)			35	V
Junction Capacitance	$C_J$	$V_R = 0\text{V}$ , $f = 1\text{MHz}$		1		pF

**TPGC24C**

Parameter	Symbol	Test Condition	Min	Typ	Max	Unit
Reverse Working Voltage	$V_{RWM}$				24.0	V
Breakdown Voltage	$V_{BR}$	$I_T = 1\text{mA}$	26.7			V
Reverse Leakage Current	$I_R$	$V_{RWM} = 24\text{V}$			0.2	$\mu\text{A}$
Clamping Voltage	$V_C$	$I_{PP} = 1\text{A}$ (8 x 20 $\mu\text{s}$ pulse)			43	V
Clamping Voltage	$V_C$	$I_{PP} = 8\text{A}$ (8 x 20 $\mu\text{s}$ pulse)			55	V
Junction Capacitance	$C_J$	$V_R = 0\text{V}$ , $f = 1\text{MHz}$		1		pF

**TPGC30C**

Parameter	Symbol	Test Condition	Min	Typ	Max	Unit
Reverse Working Voltage	$V_{RWM}$				30.0	V
Breakdown Voltage	$V_{BR}$	$I_T = 1\text{mA}$	33.3			V
Reverse Leakage Current	$I_R$	$V_{RWM} = 30\text{V}$			0.2	$\mu\text{A}$
Clamping Voltage	$V_C$	$I_{PP} = 1\text{A}$ (8 x 20 $\mu\text{s}$ pulse)			50	V
Clamping Voltage	$V_C$	$I_{PP} = 6\text{A}$ (8 x 20 $\mu\text{s}$ pulse)			75	V
Junction Capacitance	$C_J$	$V_R = 0\text{V}$ , $f = 1\text{MHz}$		1		pF

**Typical Performance Characteristics (TA=25°C unless otherwise Specified)**

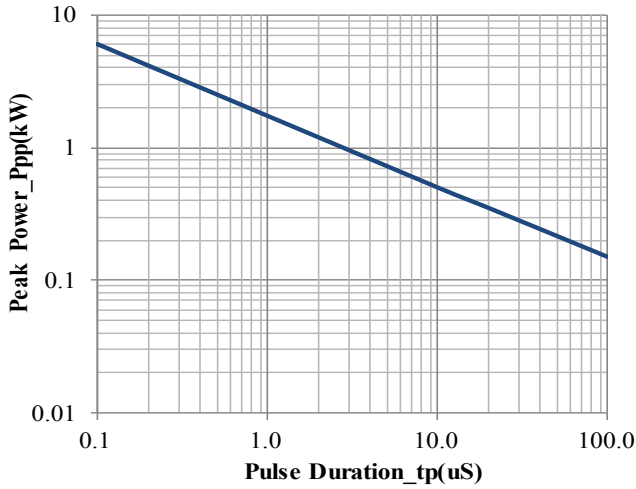

**Peak Pulse Power vs. Pulse Time**

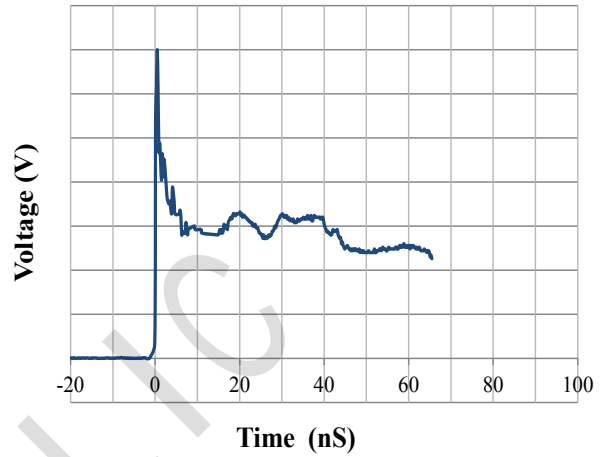

**IEC61000-4-2 Pulse Waveform**

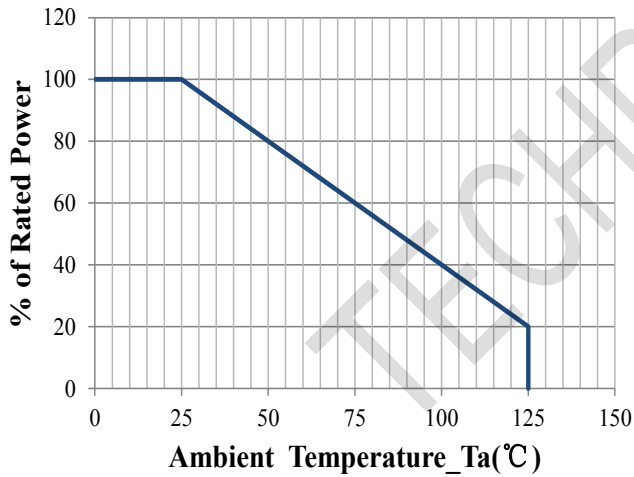

**Power Derating Curve**

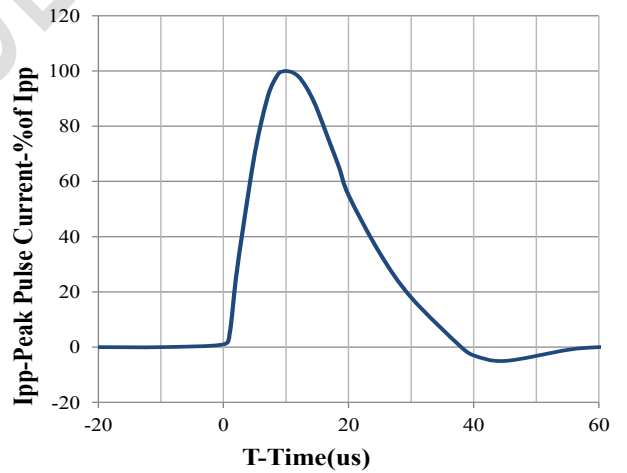

**8 X 20us Pulse Waveform**

**SOD-323 Package Outline Drawing**

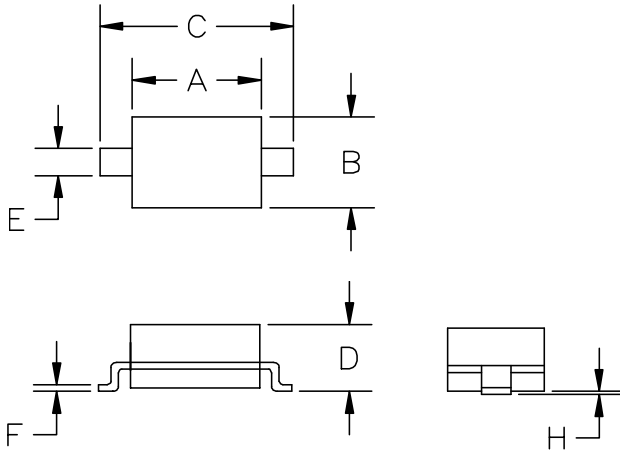

SYM	DIMENSIONS			
	MILLIMETERS		INCHES	
	MIN	MAX	MIN	MAX
A	1.50	1.80	0.060	0.071
B	1.20	1.40	0.045	0.054
C	2.30	2.70	0.090	0.107
D	-	1.10	-	0.043
E	0.30	0.40	0.012	0.016
F	0.10	0.25	0.004	0.010
H	-	0.10	-	0.004

**Suggested Land Pattern**

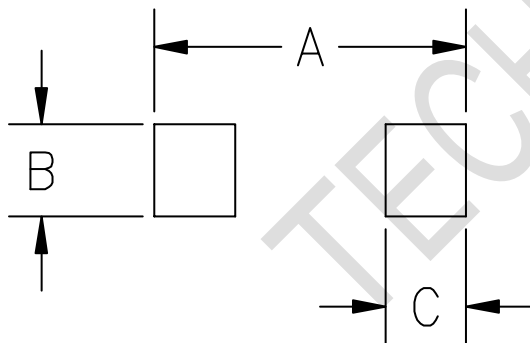

SYM	DIMENSIONS	
	MILLIMETERS	INCHES
A	3.15	0.120
B	0.80	0.031
C	0.80	0.031

## X-ON Electronics

Largest Supplier of Electrical and Electronic Components

*Click to view similar products for [ESD Suppressors / TVS Diodes](#) category:*

*Click to view products by [TECH PUBLIC](#) manufacturer:*

Other Similar products are found below :

[NTE4902](#) [P4SMAJ15A](#) [P4SMAJ26A](#) [SMAJ400CA-TP](#) [TGL34-47CA](#) [ESDAULC45-1BF4](#) [SM1605E3/TR13](#) [SMF20A-TP](#) [P4SMAJ12A](#)  
[CPDUR24V-HF](#) [CPDQC5V0USP-HF](#) [CPDQC5V0-HF](#) [MPLAD30KP45CAE3](#) [MMBZ27VCLQ-7-F](#) [MMAD1108/TR13](#) [MPLAD30KP24A](#)  
[ACPDQC5V0R-HF](#) [DFLT170A-7](#) [NTE4900](#) [NTE4926](#) [NTE4938](#) [SMF22A-TP](#) [SMF12A-TP](#) [SLVU2.8-TP](#) [SMLJ6.5CA-TP](#) [SMAJ6.5CA-](#)  
[TP](#) [MMAD1108E3/TR13](#) [D5V0M1U2LP3-7](#) [SMAJ400A-TP](#) [AOZ8811DT-03](#) [AOZ8831DI-05](#) [AOZ8831DT-03](#) [SMAJ188CA](#) [3SMC33CA](#)  
[BK](#) [CPDQC3V3C-HF](#) [CPDQC12VE-HF](#) [MPLAD30KP170CA](#) [82357120100](#) [5.0SMLJ15CA-TP](#) [5KP18A-TP](#) [P6KE8.2A-TP](#)  
[MPLAD30KP43CAE3](#) [SMAJ43A-TP](#) [D5V0F6U8LP33-7](#) [TVS5501V10MUT5G](#) [5.0SMLJ24CA-TP](#) [SMAJ110CA-TP](#) [MPLAD15KP75CAE3](#)  
[MMAD1103e3/TR13](#) [DFLT40AQ-7](#)