

## General Description

The TPRT9078 is a low-dropout (LDO) voltage regulator with enable function that operates from a 1.2V to 5.5V supply. It provides up to 450mA of output current in miniaturized packaging.

The feature of 2 $\mu$ A low quiescent current and 0.5 $\mu$ A shutdown current are ideal for the battery application with long service life. The other features include current limit function, over temperature protection and output discharge function.

## Features

- 2 $\mu$ A Ground Current at no Load
- $\pm 2\%$  Output Accuracy
- 450mA Output Current
- 10nA Disable Current (by option)
- Wide Operating Input Voltage Range: 1.2V to 5.5V
- Dropout Voltage: 0.18V at 300mA ( $V_{OUT}=3.3V$ )
- Support Fixed Output Voltage 1.2V, 1.5V, 1.6V, 1.8V, 2.5V, 2.8V, 3.0V, 3.3V
- Stable with Ceramic or Tantalum Capacitor
- Current Limit Protection
- Over-Temperature Protection
- SOT23-3, SOT23-5, DFN-4(1x1) and DFN-6(2x2) Packages Available

## Applications

- Portable, Battery Powered Equipment
- Low Power Microcontrollers
- Laptop, Palmtops and PDAs
- Wireless Communication Equipment
- Audio/Video Equipment

## Ordering Information

### TPRT9078-18GJ5

GJ5: SOT23-5 Package  
GQZ: DFN1X1 Package

Output voltage: 12=1.2V  
15=1.5V  
18=1.8V  
30=3.0V  
33=3.3V  
XX=X.XV

## Marking Information

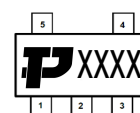

**TP**: Logo  
XXX: Marking ID

## BLOCK DIAGRAM

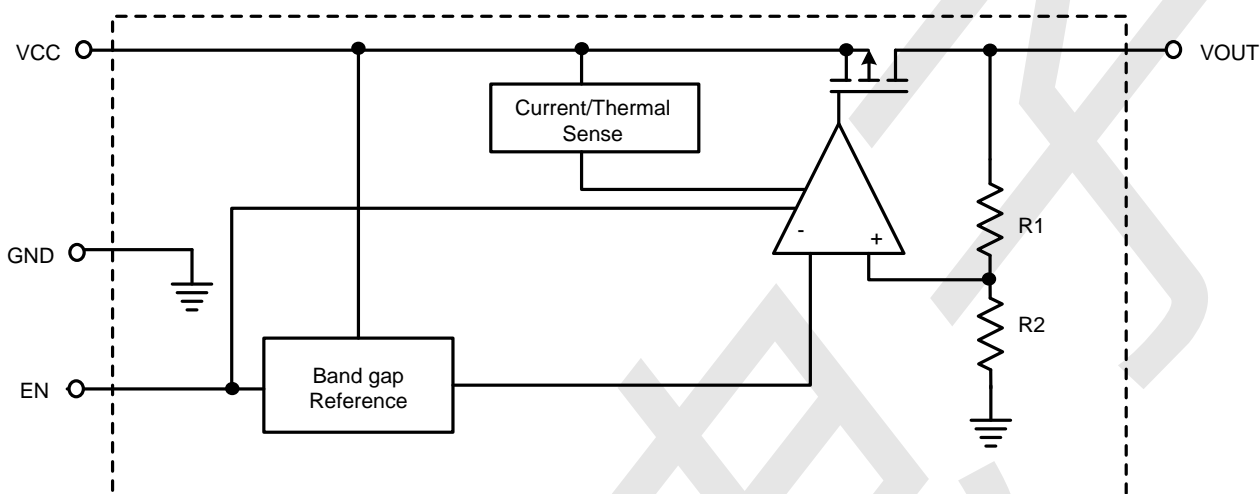

## PIN CONFIGURATION

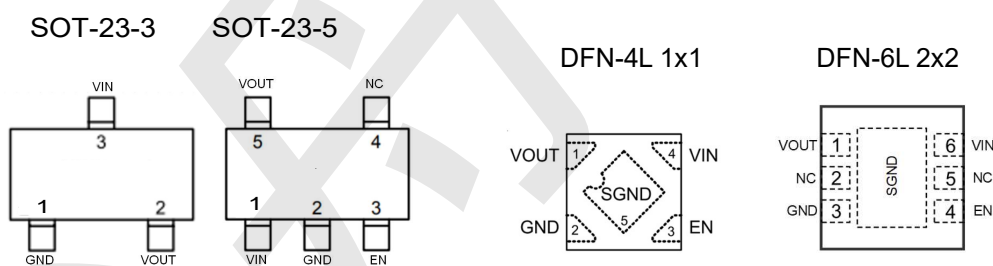

Pin No				Pin Name	Pin Function
SOT-23-3	SOT-23-5	DFN-1X1	DFN-2X2		
1	2	2	3	GND	Ground
2	5	1	1	VOUT	Output of the Regulator
3	1	4	6	VIN	Input of Supply Voltage.
	3	3	4	EN	Enable Control Input.
	4		2,5	NC	No internal connection

**Absolute Maximum Rating** ( $T_A=25^{\circ}\text{C}$  unless otherwise noted)

VIN Pin to GND Pin Voltage .....	-0.3V to 6.5V
VOUT Pin and EN Pin to GND Pin Voltage .....	-0.3V to 6V
VOUT Pin to VIN Pin Voltage .....	-6V to 0.3V
Storage Temperature Range .....	-60°C~150°C
Lead Temperature (Soldering, 10 sec) .....	260°C
Junction Temperature .....	150°C
Operating Ambient Temperature Range $T_A$ .....	-40°C~85°C
Thermal Resistance Junction to Case, $R_{\theta JC}$	
SOT23-3 .....	115°C/W
SOT23-5 .....	115°C/W
DFN-4(1x1) .....	65°C/W
DFN-6(2x2) .....	30°C/W
Thermal Resistance Junction to Ambient, $R_{\theta JA}$	
SOT23-3 .....	250°C/W
SOT23-5 .....	250°C/W
DFN-4(1x1) .....	195°C/W
DFN-6(2x2) .....	165°C/W

**Electrical Characteristics** (T =25°C unless otherwise noted)

(V<sub>IN</sub>=5V, V<sub>EN</sub>=5V, T<sub>A</sub>=25°C, unless otherwise specified) (Note 1)

PARAMETER	TEST CONDITIONS	SYMBOL	MIN.	TYP.	MAX.	UNIT
Supply Voltage		V <sub>IN</sub>	1.2		5.5	V
DC Output Voltage Accuracy	I <sub>LOAD</sub> =0.1mA		-2		2	%
SNS Input Current	SNS=V <sub>OUT</sub>	I <sub>SNS</sub>		0.5		μA
Dropout Voltage (Note 2)	I <sub>LOAD</sub> =300mA, V <sub>OUT</sub> ≥3V	V <sub>DROP_3V</sub>		0.18		V
	I <sub>LOAD</sub> =300mA, V <sub>OUT</sub> =2.8V	V <sub>DROP_2.8V</sub>		0.23		
	I <sub>LOAD</sub> =300mA, V <sub>OUT</sub> =2.5V	V <sub>DROP_2.5V</sub>		0.23		
	I <sub>LOAD</sub> =300mA, V <sub>OUT</sub> =1.8V	V <sub>DROP_1.8V</sub>		0.28		
	I <sub>LOAD</sub> =300mA, V <sub>OUT</sub> =1.5V	V <sub>DROP_1.5V</sub>		0.36		
	I <sub>LOAD</sub> =300mA, V <sub>OUT</sub> =1.2V	V <sub>DROP_1.2V</sub>		0.45		
GND Current	I <sub>LOAD</sub> =0mA	I <sub>Q</sub>		2		μA
Shutdown GND Current	V <sub>EN</sub> =0V, V <sub>OUT</sub> =0V	I <sub>SD</sub>		0.1	0.5	μA
V <sub>OUT</sub> Shutdown Leakage Current	V <sub>EN</sub> =0V, V <sub>OUT</sub> =0V	I <sub>LEAK</sub>		0.1	0.5	μA
Enable Threshold Voltage	EN Rising	V <sub>IH</sub>	1.0			V
	EN Falling	V <sub>IL</sub>			0.4	
EN Input Current	V <sub>EN</sub> =5V	I <sub>EN</sub>		10	100	nA
Line Regulation	I <sub>LOAD</sub> =30mA, 1.5V≤V <sub>IN</sub> ≤5.5V or (V <sub>OUT</sub> +0.2V)≤V <sub>IN</sub> ≤5.5V	ΔLINE		0.2		%
Load Regulation	10mA≤I <sub>LOAD</sub> ≤300mA	ΔLOAD		0.2		%
Output Current Limit	V <sub>OUT</sub> =0V	I <sub>LIM</sub>	450	500		mA
Power Supply Rejection Ratio	V <sub>OUT</sub> =1.2V, I <sub>LOAD</sub> =5mA, V <sub>IN</sub> =2V, f=100Hz	PSRR		80		dB
	V <sub>OUT</sub> =1.2V, I <sub>LOAD</sub> =5mA, V <sub>IN</sub> =2V, f=1kHz			75		
Output Voltage Noise	V <sub>IN</sub> =3.5V, I <sub>LOAD</sub> =0.1A, BW=10Hz to 100kHz, C <sub>OUT</sub> =1μF, V <sub>OUT</sub> =1.2V			80		μV <sub>RMS</sub>
	V <sub>IN</sub> =3.5V, I <sub>LOAD</sub> =0.1A, BW=10Hz to 100kHz, C <sub>OUT</sub> =1μF, V <sub>OUT</sub> =2.8V			120		
Thermal Shutdown Temperature	I <sub>LOAD</sub> =10mA	T <sub>SD</sub>		155		°C
Thermal Shutdown Hysteresis	I <sub>LOAD</sub> =10mA	ΔT <sub>SD</sub>		15		°C
Discharge Resistance	V <sub>EN</sub> =0V, V <sub>OUT</sub> =0.1V			100		Ω

**TYPICAL APPLICATION**

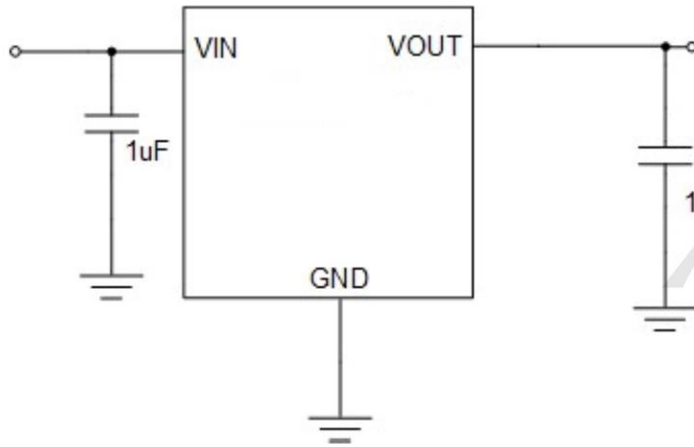

Figure 1: Application circuit of Fixed V<sub>OUT</sub> LDO

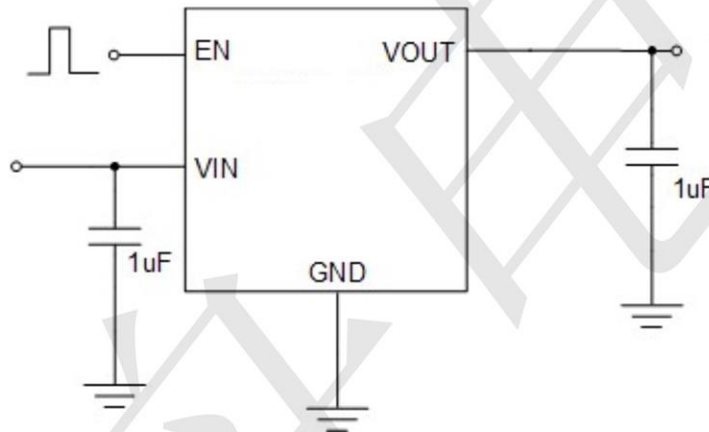

Figure 2: Application circuit of Fixed V<sub>OUT</sub> LDO with enable function

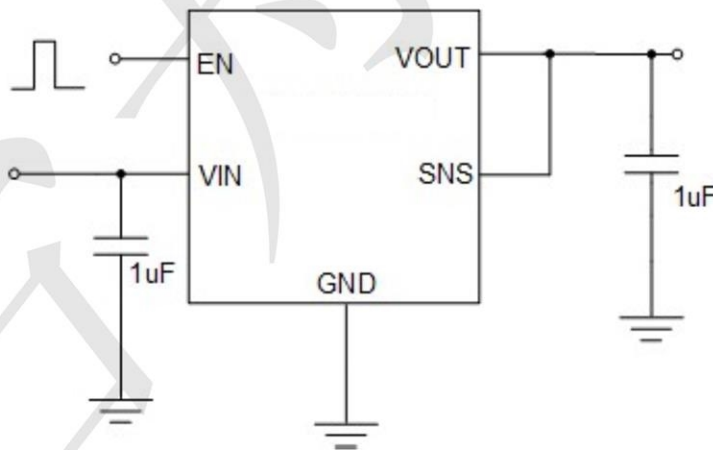
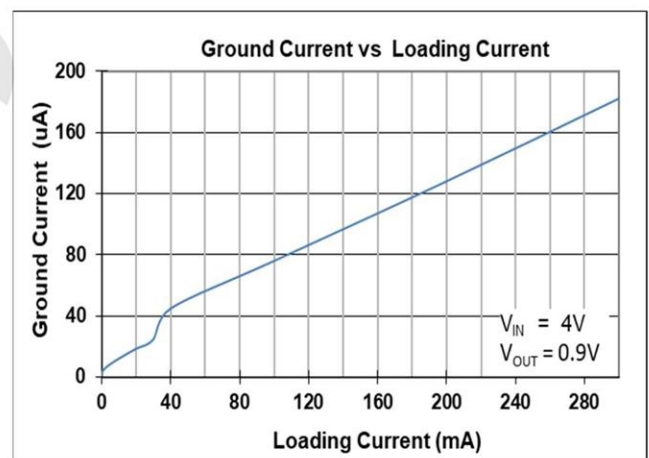
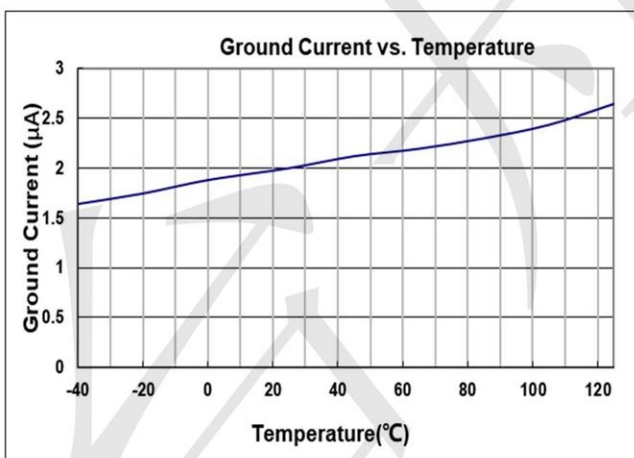
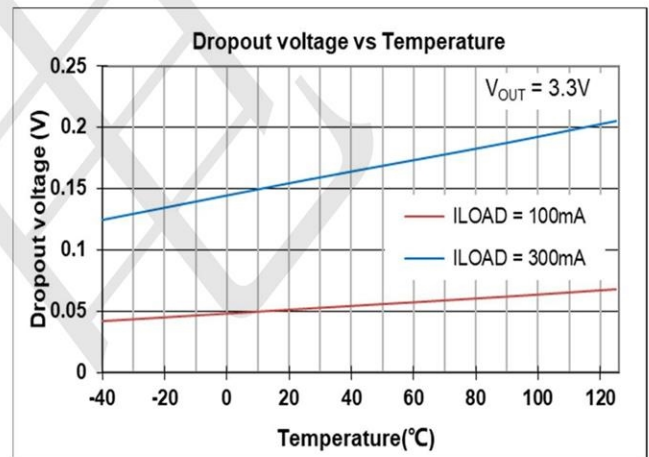
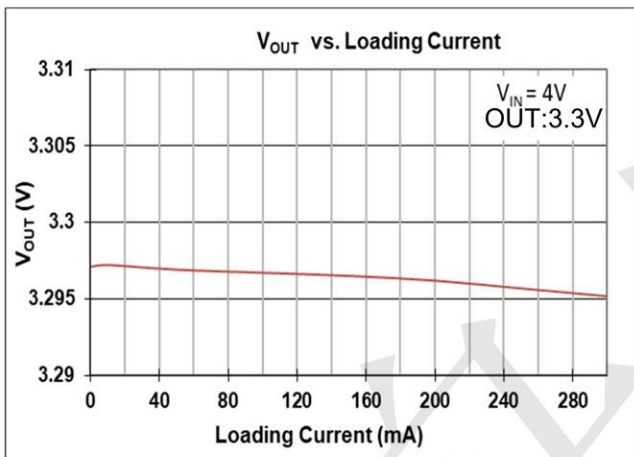
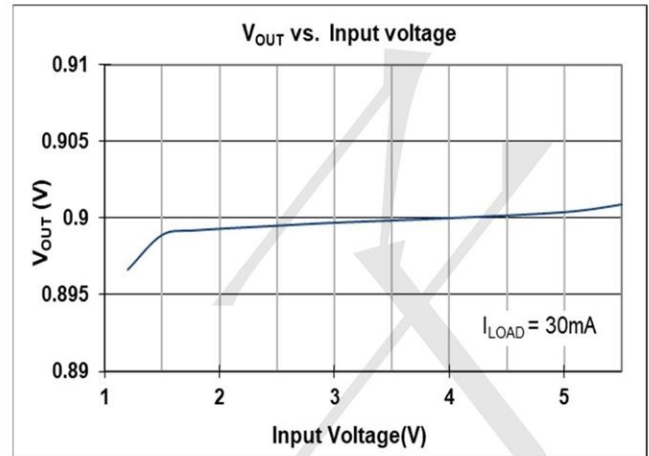
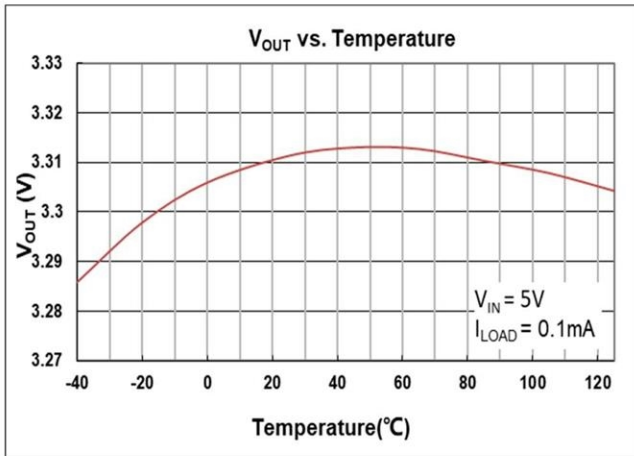
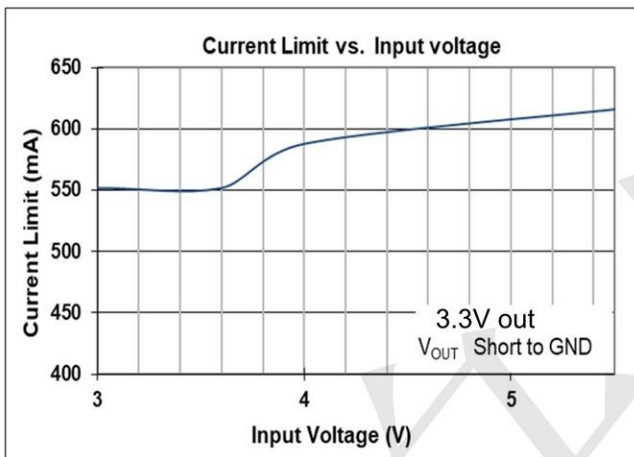
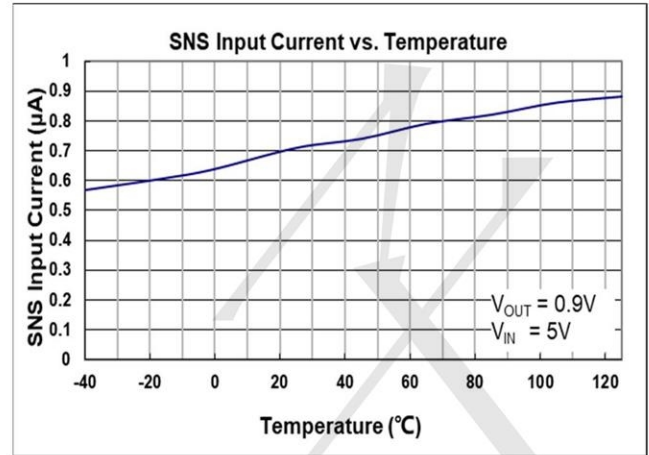
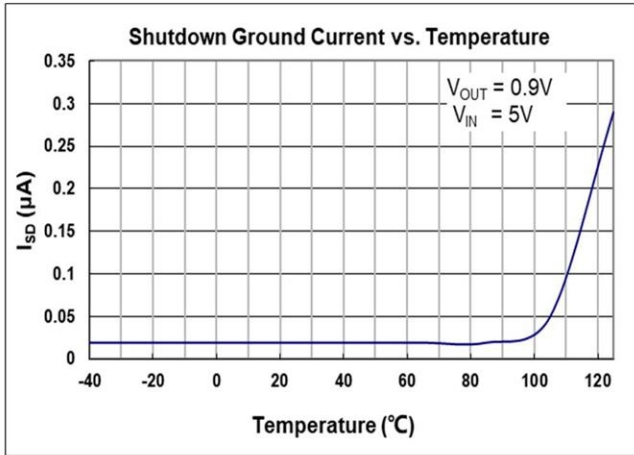
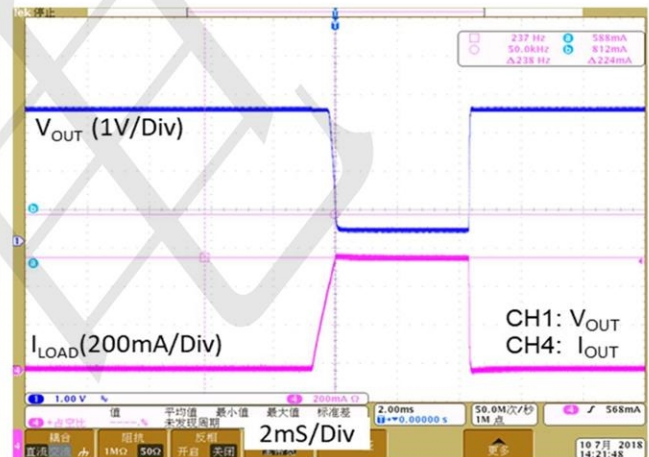

Figure 3: Application circuit of Fixed V<sub>OUT</sub> LDO with enable and sense functions





**Current Limit Response**



**Load Transient Response I**

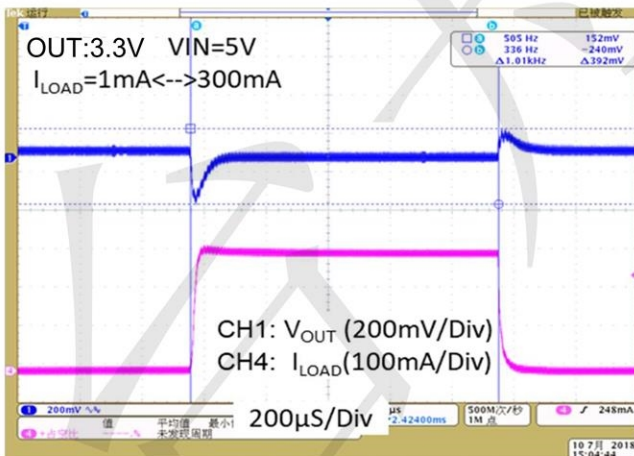

**Load Transient Response II**

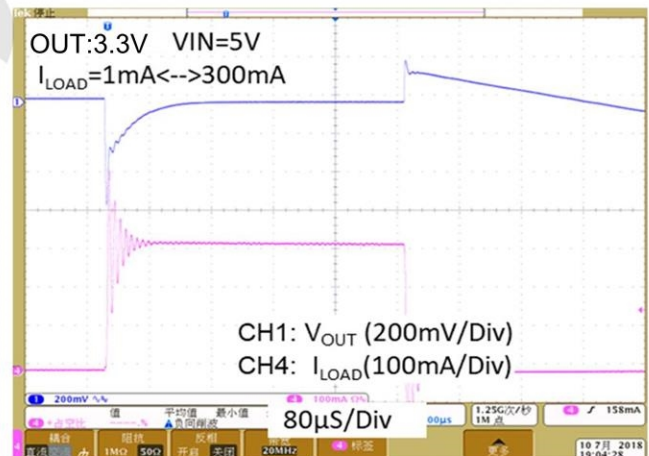

Line Transient Response

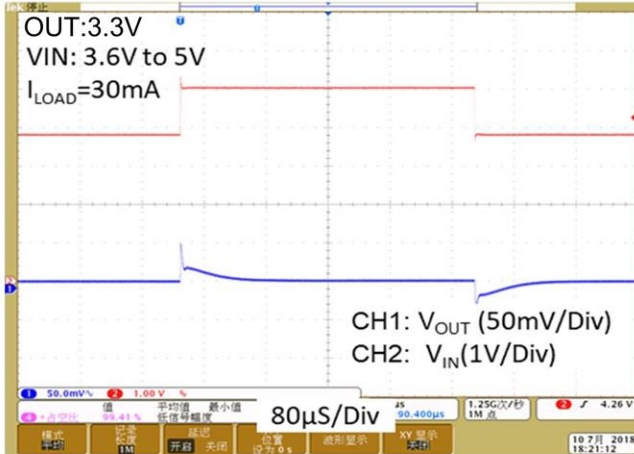

$V_{OUT}$  Turn On/Off by EN

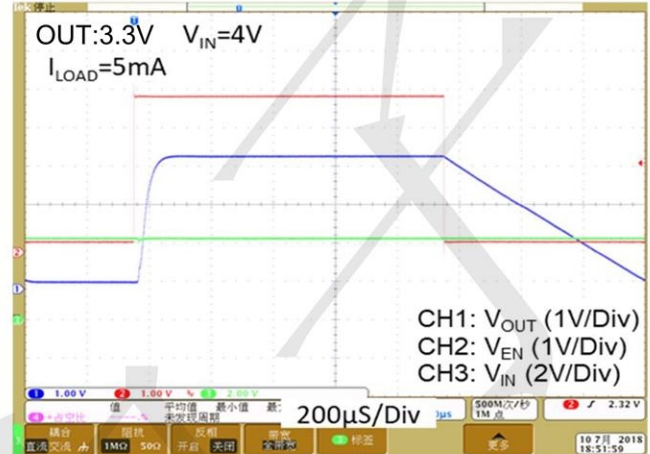





**Package informantion**

**DFN2X2-6L Outline Dimensions**

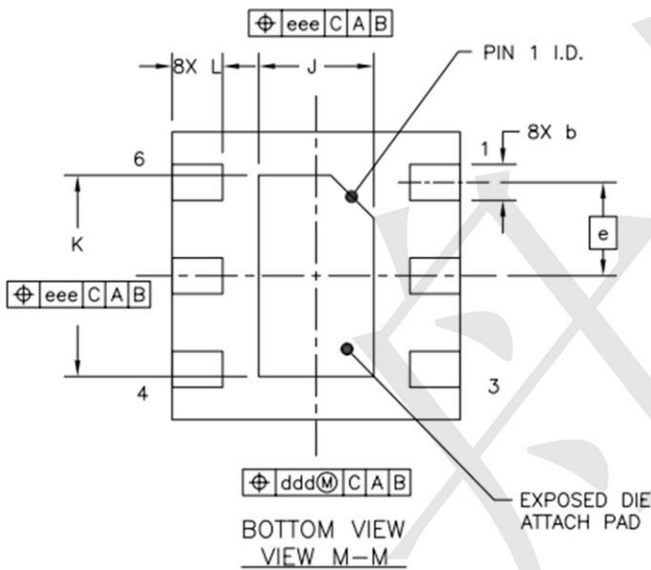
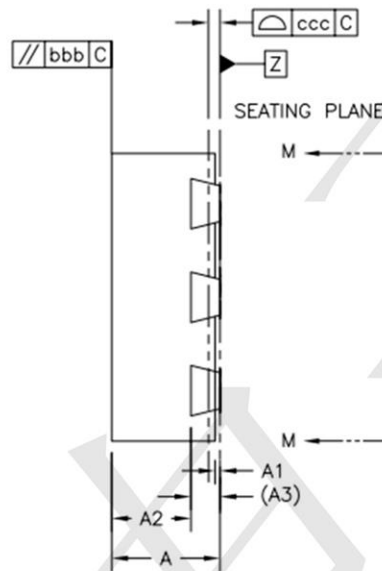
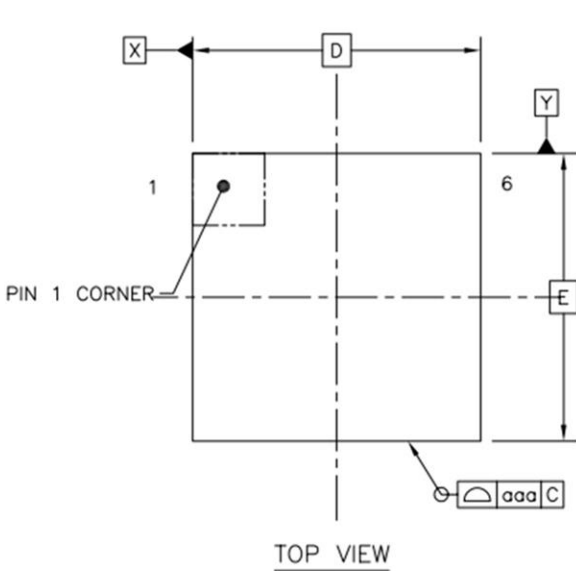

DESCRIPTION	SYMBOL	MILLIMETER			
		MIN	NOM	MAX	
TOTAL THICKNESS	A	0.7	0.75	0.8	
STAND OFF	A1	0	0.035	0.05	
MOLD THICKNESS	A2	---	0.55	0.575	
L/F THICKNESS	A3	0.203 REF			
LEAD WIDTH	b	0.20	0.25	0.30	
BODY SIZE	X	D 2 BSC			
	Y	E 2 BSC			
LEAD PITCH	e	0.65 BSC			
EP SIZE	X	J	0.75	0.8	0.85
	Y	K	1.35	1.4	1.45
LEAD LENGTH	L	0.30	0.35	0.40	
PACKAGE EDGE TOLERANCE	aaa	0.05			
MOLD FLATNESS	bbb	0.1			
COPLANARITY	ccc	0.08			
LEAD OFFSET	ddd	0.1			
EXPOSED PAD OFFSET	eee	0.1			

**NOTES**

1.0 COPLANARITY APPLIES TO LEADS, CORNER LEADS AND DIE ATTACH PAD.



**Package informantion**

**4-pin DFN-4L Outline Dimensions**

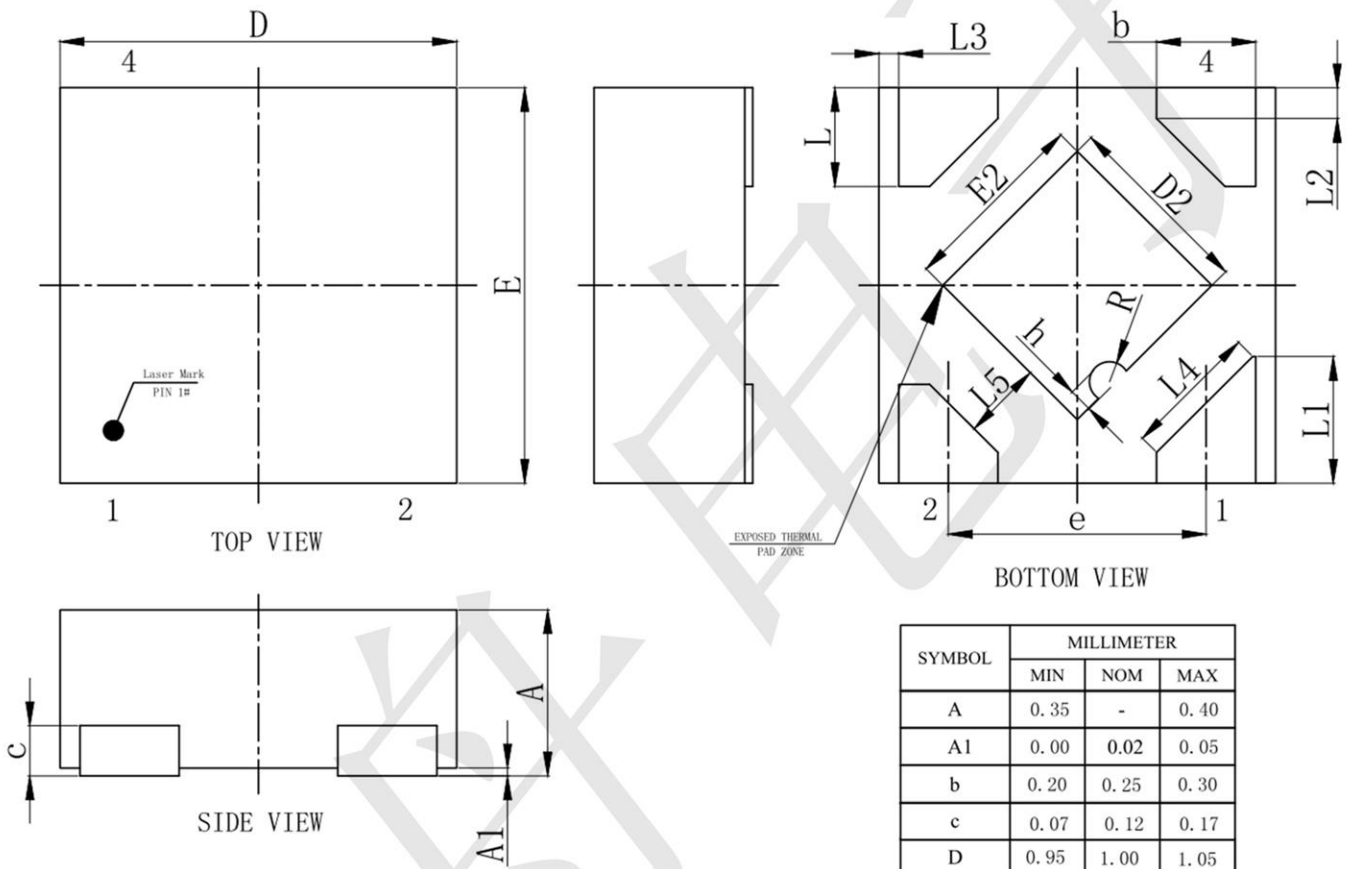

SYMBOL	MILLIMETER		
	MIN	NOM	MAX
A	0.35	-	0.40
A1	0.00	0.02	0.05
b	0.20	0.25	0.30
c	0.07	0.12	0.17
D	0.95	1.00	1.05
D2	0.38	0.48	0.58
e	0.65BSC		
E	0.95	1.00	1.05
E2	0.38	0.48	0.58
L	0.20	0.25	0.30
L1	0.27	0.32	0.37
L2	0.077REF		
L3	0.05REF		
L4	0.34REF		
L5	0.20REF		
R	0.05REF		
h	0.06REF		



**Package informantion**

**3-pin SOT23-3 Outline Dimensions**

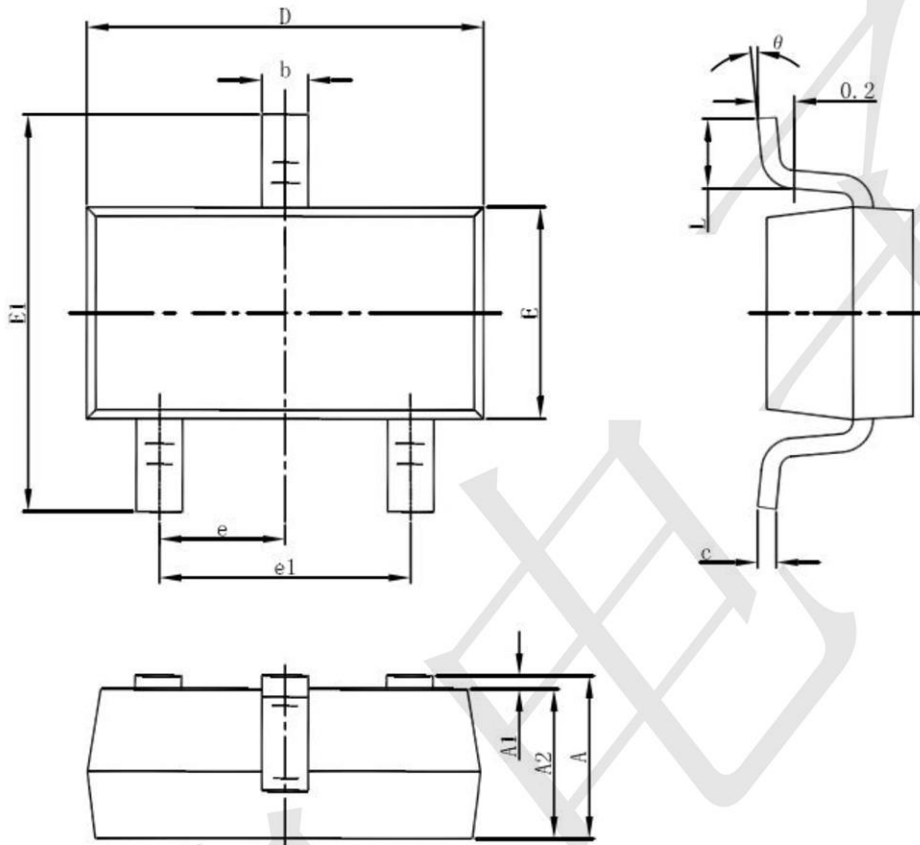

Symbol	Dimensions In Millimeters		Dimensions In Inches	
	Min	Max	Min	Max
A	1.050	1.250	0.041	0.049
A1	0.000	0.100	0.000	0.004
A2	1.050	1.150	0.041	0.045
b	0.300	0.500	0.012	0.020
c	0.100	0.200	0.004	0.008
D	2.820	3.020	0.111	0.119
E	1.500	1.700	0.059	0.067
E1	2.650	2.950	0.104	0.116
e	0.950(BSC)		0.037(BSC)	
e1	1.800	2.000	0.071	0.079
L	0.300	0.600	0.012	0.024
theta	0°	8°	0°	8°



**Package informantion**

[www.sot23.com.tw](http://www.sot23.com.tw)

**3-pin SOT23-5 Outline Dimensions**

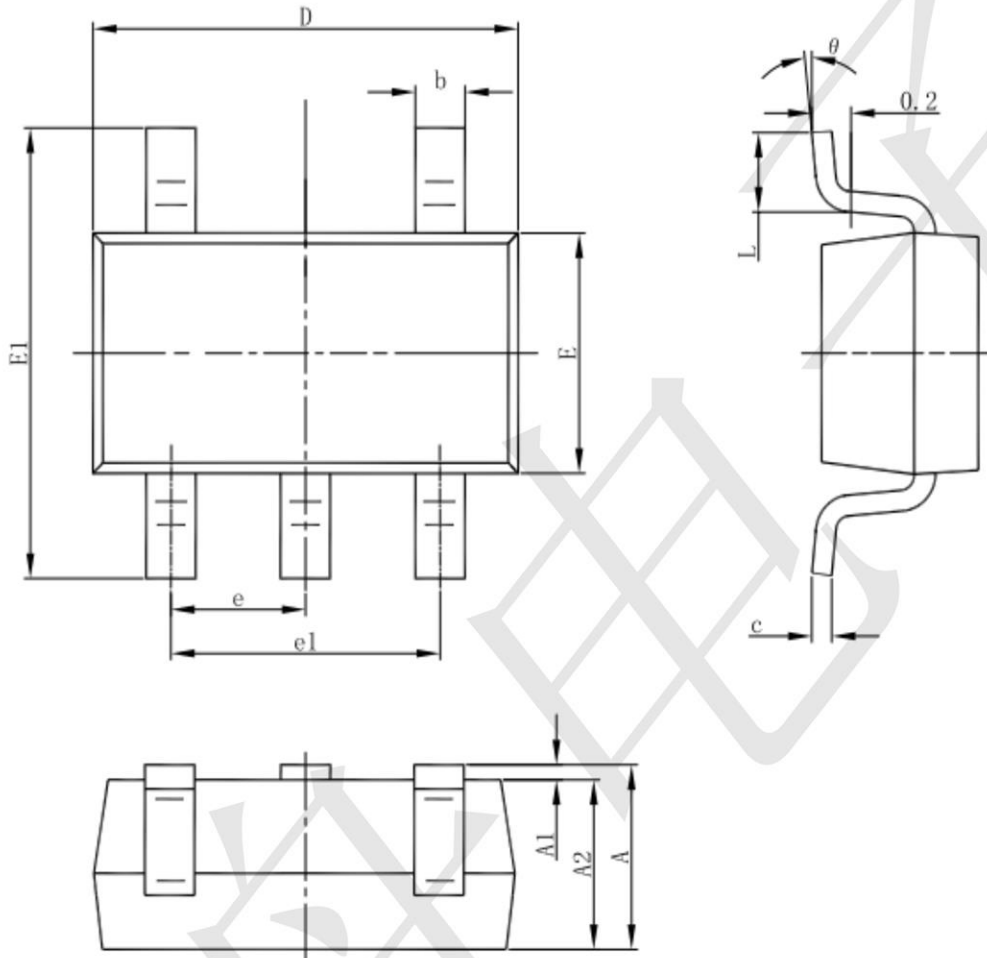

Symbol	Dimensions In Millimeters		Dimensions In Inches	
	Min	Max	Min	Max
A	1.050	1.250	0.041	0.049
A1	0.000	0.100	0.000	0.004
A2	1.050	1.150	0.041	0.045
b	0.300	0.500	0.012	0.020
c	0.100	0.200	0.004	0.008
D	2.820	3.020	0.111	0.119
E	1.500	1.700	0.059	0.067
E1	2.650	2.950	0.104	0.116
e	0.950(BSC)		0.037(BSC)	
e1	1.800	2.000	0.071	0.079
L	0.300	0.600	0.012	0.024
theta	0°	8°	0°	8°

## X-ON Electronics

Largest Supplier of Electrical and Electronic Components

*Click to view similar products for [Linear Voltage Regulators](#) category:*

*Click to view products by [TECH PUBLIC](#) manufacturer:*

Other Similar products are found below :

[LV56831P-E](#) [LV5684PVD-XH](#) [MCDTSA6-2R](#) [L7815ACV-DG](#) [PQ3DZ53U](#) [LV56801P-E](#) [TLE42794G](#) [L78L05CZ/1SX](#) [L78LR05DL-MA-E](#) [636416C](#) [714954EB](#) [BA033LBSG2-TR](#) [LV5680P-E](#) [L78M15CV-DG](#) [L79M05T-E](#) [TLS202A1MBVHTSA1](#) [L78LR05D-MA-E](#) [NCV317MBTG](#) [NTE7227](#) [LV5680NPVC-XH](#) [LT1054CN8](#) [MP2018GZD-5-Z](#) [MP2018GZD-33-Z](#) [MIC5281-3.3YMM](#) [MC78L06BP-AP](#) [TA48LS05F\(TE85L,F\)](#) [TA78L12F\(TE12L,F\)](#) [TC47BR5003ECT](#) [TCR2LN12,LF\(S](#) [TCR2LN28,LF\(S](#) [TCR2LN30,LF\(S](#) [TCR3DF295,LM\(CT](#) [TCR3DF40,LM\(CT](#) [BA178M20CP-E2](#) [L78M12ABDT](#) [LM7812SX/NOPB](#) [LR645N3-G-P003](#) [LR645N3-G-P013](#) [ZXTR2005P5-13](#) [SCD7812BTG](#) [TCR3DF335,LM\(CT](#) [ZXTR2012K-13](#) [TLE42994E V33](#) [ZXTR2008K-13](#) [ZXTR2005K-13](#) [L88R05DL-E](#) [ADP3300ARTZ-2.7RL7](#) [LM120K-15/883](#) [IFX54441LDVXUMA1](#) [LM317D2T-TR](#)