

## General Description

The TPV358 is a single supply, low power CMOS dual operational amplifier; these amplifiers offer bandwidth of 1MHz, rail-to-rail inputs and outputs, and single-supply operation from 2.2V to 5.5V. The embedded anti-RF filter can significantly increase the RF immunity without extra components. Typical low quiescent supply current of 80μA in dual operational amplifiers within one chip and very low input bias current of 10pA make the devices an ideal choice for low offset, low power consumption and high impedance applications such as smoke detectors, photodiode amplifiers, and other sensors.

The TPV358 is available in SOP-8L and MSOP-8L packages. The extended temperature range of -40 °C to +125 °C over all supply voltages offers additional design flexibility.

## Features

- Single-Supply Operation from +2.2V ~ +5.5V
- Rail-to-Rail Input / Output
- Gain-Bandwidth Product: 1MHz (Typ.)
- Low Input Bias Current: 10pA (Typ.)
- Low Offset Voltage: 5mV (Max.)
- Quiescent Current: 40μA per Amplifier (Typ.)
- Operating Temperature: -40°C ~ +125°C
- Available in SOP-8L and MSOP-8L Packages

## Applications

- Portable Equipment
- Mobile Communications
- Smoke Detector
- Medical Instrumentation
- Battery-Powered Instruments
- Sensor Interface
- Handheld Test Equipment

## Ordering Information

Part Number	Package	QTY Per Reel	Reel Size
TPV358S8	SOP-8L	4000	12"
TPV358M8	MSOP-8L	3000	12"

## Pin Assignments

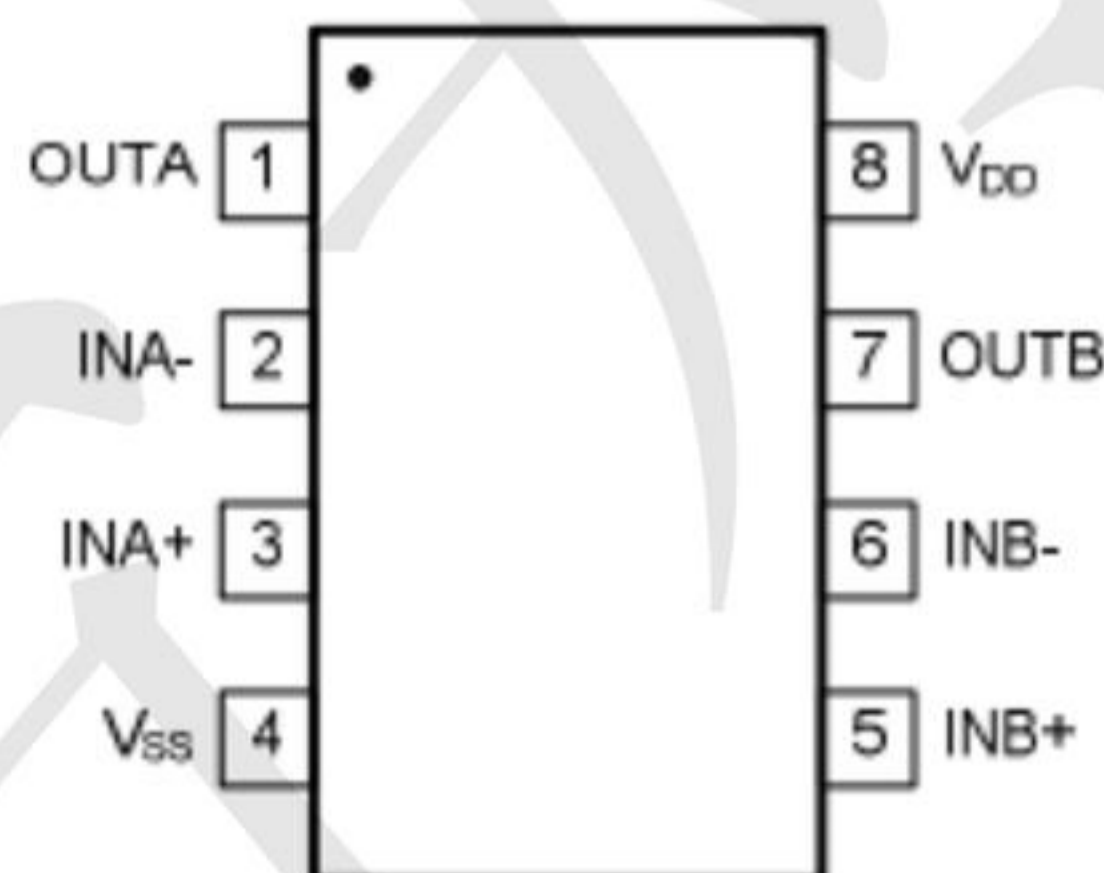

## Marking:

TPV358S8(SOP8)

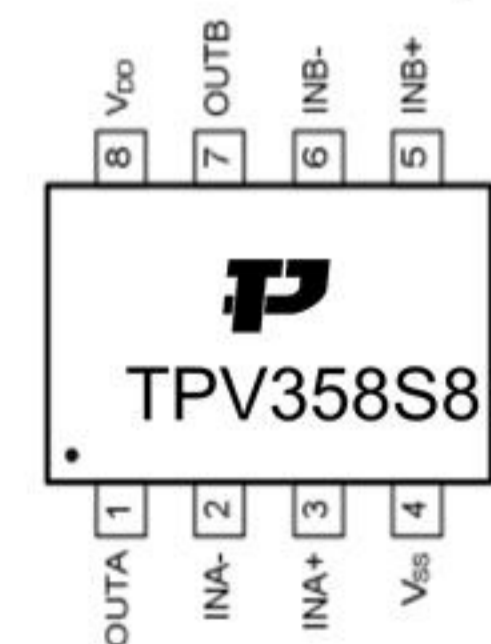

TPV358M8(MSOP-8L)

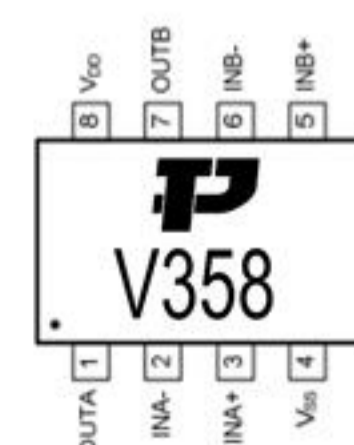

**Figure 1. Pin Assignment Diagram (SOP-8L and MSOP-8L Package)**

## Ordering Information

**TPV358S8**

**Package Type**  
S8 : SOP8  
M8:MSOP8L

TP= TECH PUBLIC

## Electrical Characteristics

### Absolute Maximum Ratings

Condition	Min	Max
Power Supply Voltage (VDD to Vss)	-0.5V	+7V
Analog Input Voltage (IN+ or IN-)	Vss-0.5V	VDD+0.5V
PDB Input Voltage	Vss-0.5V	+7V
Operating Temperature Range	-40°C	+125°C
Junction Temperature	+150°C	
Storage Temperature Range	-65°C	+150°C
Lead Temperature (soldering, 10sec)	+300°C	
Package Thermal Resistance (TA=+25°C)		
SOP-8L, $\theta_{JA}$	130°C	
MSOP-8L, $\theta_{JA}$	210°C	

**Note:** Stress greater than those listed under Absolute Maximum Ratings may cause permanent damage to the device. This is a stress rating only and functional operation of the device at these or any other conditions outside those indicated in the operational sections of this specification are not implied. Exposure to absolute maximum rating conditions for extended periods may affect reliability.

### Electrical Characteristics

( $V_{DD} = +5V$ ,  $V_{SS} = 0V$ ,  $V_{CM} = 0V$ ,  $V_{OUT} = V_{DD}/2$ ,  $R_L = 100K$  tied to  $V_{DD}/2$ ,  $SHDNB = V_{DD}$ ,  $T_A = -40^\circ C$  to  $+125^\circ C$ , unless otherwise noted. Typical values are at  $T_A = +25^\circ C$ .) (Notes 1)

Parameter	Symbol	Conditions	Min.	Typ.	Max.	Units
Supply-Voltage Range	$V_{DD}$	Guaranteed by the PSRR test	2.2	-	5.5	V
Quiescent Supply Current (per Amplifier)	$I_Q$	$V_{DD} = 5V$	30	40	60	$\mu A$
Input Offset Voltage	$V_{OS}$		-	0.5	$\pm 5$	mV
Input Offset Voltage Tempco	$\Delta V_{OS}/\Delta T$		-	2	-	$\mu V/^\circ C$
Input Bias Current	$I_B$	(Note 2)	-	10	-	pA
Input Offset Current	$I_{OS}$	(Note 2)	-	10	-	pA
Input Common-Mode Voltage Range	$V_{CM}$		-0.1	-	$V_{DD} + 0.1$	V
Common-Mode Rejection Ratio	CMRR	$V_{DD} = 5.5V$ , $V_{SS} = 0.1V$ , $V_{CM} = V_{DD} + 0.1V$	55	65	-	dB
		$V_{SS} \leq V_{CM} \leq 5V$	60	80	-	dB
Power-Supply Rejection Ratio	PSRR	$V_{DD} = +2.5V$ to $+5.5V$	75	94	-	dB
Open-Loop Voltage Gain	$A_V$	$V_{DD} = 5V$ , $R_L = 100k\Omega$ , $0.05V \leq V_O \leq 4.95V$	100	110	-	dB
		$V_{DD} = 5V$ , $R_L = 5k\Omega$ , $0.05V \leq V_O \leq 4.95V$	70	80	-	dB
Output Voltage Swing	$V_{OUT}$	$ V_{IN+} - V_{IN-}  \leq 10mV$ , $V_{DD} - V_{OH}$	-	6	-	mV
		$R_L = 100k\Omega$ to $V_{DD}/2$ , $V_{OL} - V_{SS}$	-	6	-	mV
		$ V_{IN+} - V_{IN-}  \leq 10mV$ , $V_{DD} - V_{OH}$	-	60	-	mV
		$R_L = 5k\Omega$ to $V_{DD}/2$ , $V_{OL} - V_{SS}$	-	60	-	mV
Output Short-Circuit Current	$I_{SC}$	Sinking or Sourcing	-	$\pm 20$	-	mA
Gain Bandwidth Product	GBW	$A_V = +1V/V$	-	1	-	MHz
Slew Rate	SR	$A_V = +1V/V$	-	0.6	-	V/ $\mu s$
Settling Time	$t_s$	To 0.1%, $V_{OUT} = 2V$ step $A_V = +1V/V$	-	5	-	$\mu s$
Over Load Recovery Time		$V_{IN} \times Gain = V_S$	-	2	-	$\mu s$
Input Voltage Noise Density	$e_n$	$f = 10kHz$	-	20	-	$nV/\sqrt{Hz}$

**Note 1:** All devices are 100% production tested at  $T_A = +25^\circ C$ ; all specifications over the automotive temperature range is guaranteed by design, not production tested.

**Note 2:** Parameter is guaranteed by design.

## Application Information

### Size

TPV358 series op amps are unity-gain stable and suitable for a wide range of general-purpose applications. The small footprints of the TPV358 series packages save space on printed circuit boards and enable the design of smaller electronic products.

### Power Supply Bypassing and Board Layout

TPV358 series operates from a single 2.2V to 5.5V supply or dual  $\pm 1.1V$  to  $\pm 2.75V$  supplies. For best performance, a  $0.1\mu F$  ceramic capacitor should be placed close to the VDD pin in single supply operation. For dual supply operation, both VDD and VSS supplies should be bypassed to ground with separate  $0.1\mu F$  ceramic capacitors.

### Low Supply Current

The low supply current (typical  $80\mu A$ ) of TPV358 series will help to maximize battery life. They are ideal for battery powered Systems

### Operating Voltage

TPV358 series operate under wide input supply voltage (2.2V to 5.5V). In addition, all temperature specifications apply from  $-40^{\circ}C$  to  $+125^{\circ}C$ . Most behavior remains unchanged throughout the full operating voltage range. These guarantees ensure operation throughout the single Li-Ion battery lifetime.

### Rail-to-Rail Input

The input common-mode range of TPV358 series extends 100mV beyond the supply rails ( $V_{SS}-0.1V$  to  $V_{DD}+0.1V$ ). This is achieved by using complementary input stage. For normal operation, inputs should be limited to this range.

### Rail-to-Rail Output

Rail-to-Rail output swing provides maximum possible dynamic range at the output. This is particularly important when operating in low supply voltages. The output voltage of TPV358 series can typically swing to less than 10mV from supply rail in light resistive loads ( $>100k\Omega$ ), and 60mV of supply rail in moderate resistive loads (10k $\Omega$ ).

### Capacitive Load Tolerance

The TPV358 series can directly drive 250pF capacitive load in unity-gain without oscillation. Increasing the gain enhances the amplifier's ability to drive greater capacitive loads. In unity-gain configurations, the capacitive load drive can be improved by inserting an isolation resistor  $R_{ISO}$  in series with the capacitive load, as shown in Figure 2.

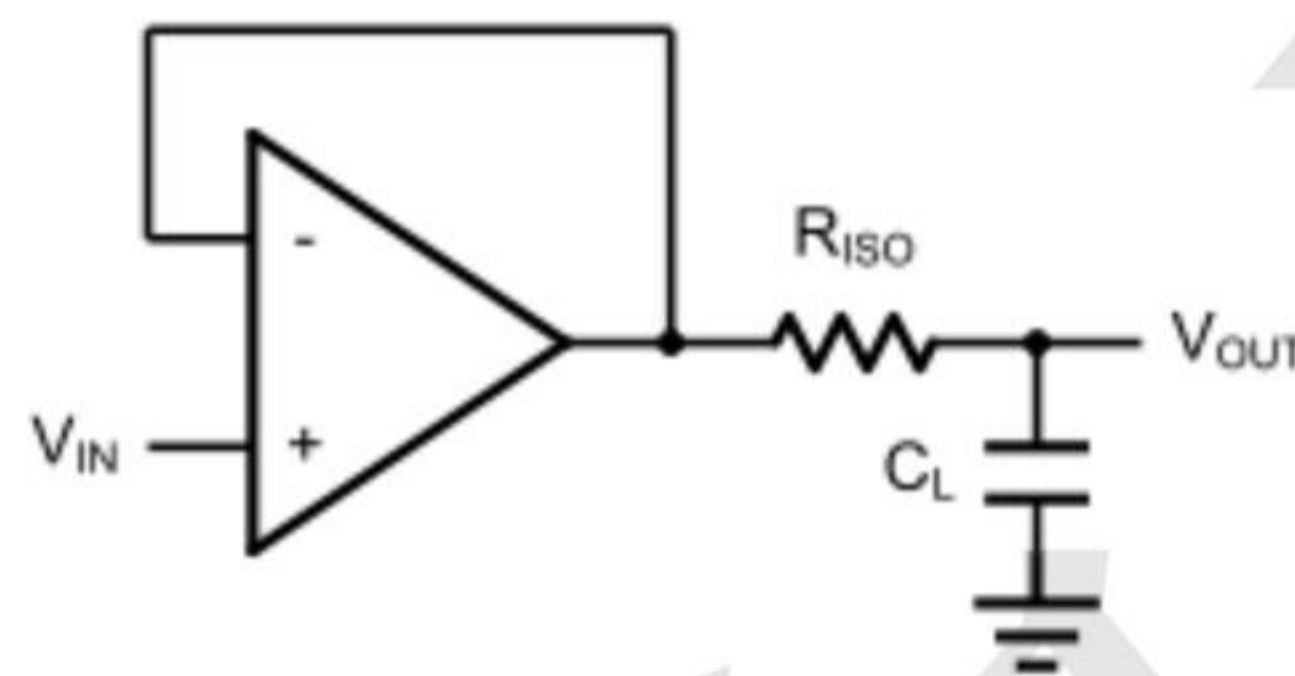

**Figure 2. Indirectly Driving a Capacitive Load Using Isolation Resistor**

The bigger the  $R_{ISO}$  resistor value, the more stable  $V_{OUT}$  will be. However, if there is a resistive load  $R_L$  in parallel with the capacitive load, a voltage divider (proportional to  $R_{ISO}/R_L$ ) is formed, this will result in a gain error.

The circuit in Figure 3 is an improvement to the one in Figure 2.  $R_F$  provides the DC accuracy by feed-forward the  $V_{IN}$  to  $R_L$ .  $C_F$  and  $R_{ISO}$  serve to counteract the loss of phase margin by feeding the high frequency component of the output signal back to the amplifier's inverting input, thereby preserving the phase margin in the overall feedback loop. Capacitive drive can be increased by increasing the value of  $C_F$ . This in turn will slow down the pulse response.

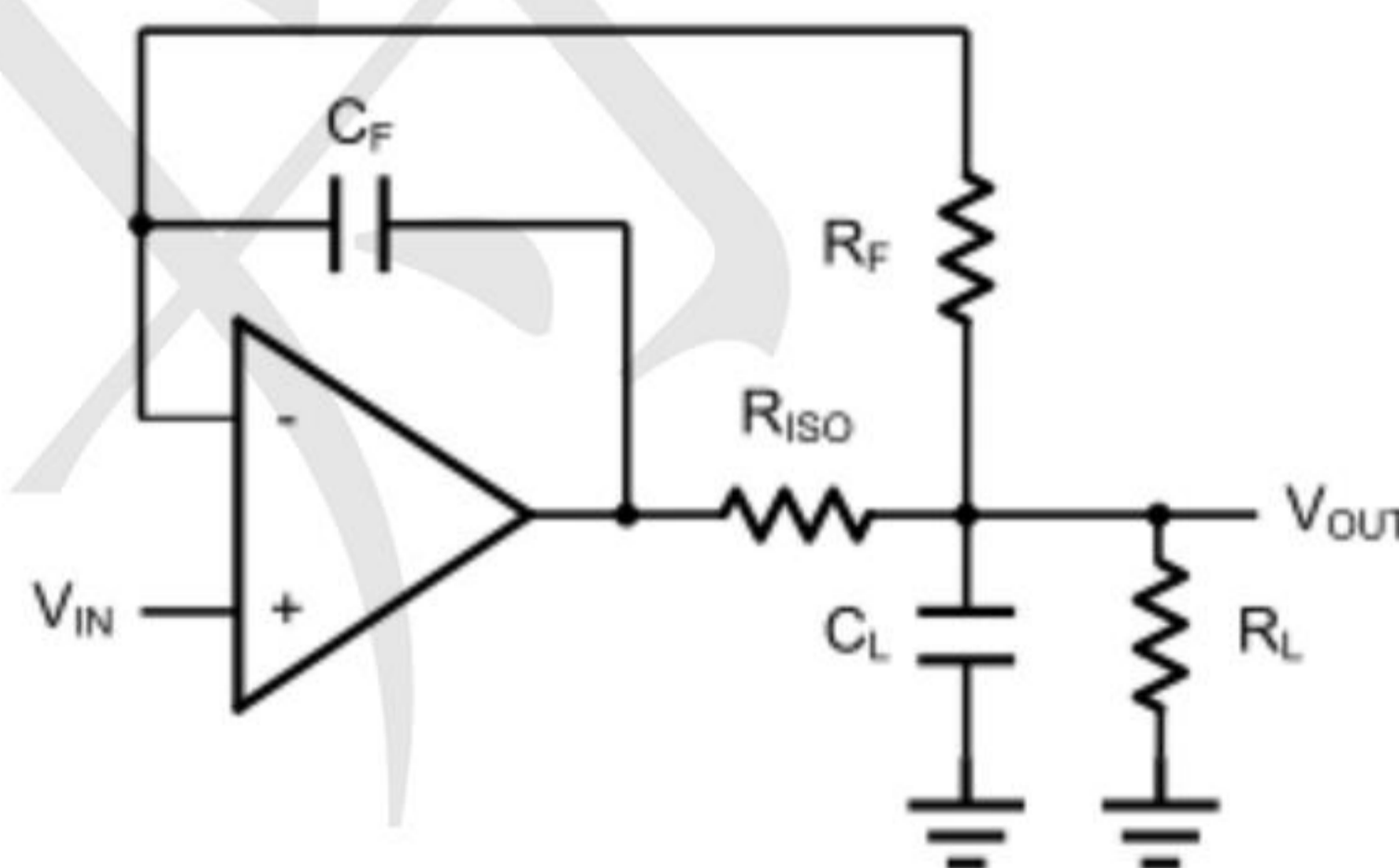

**Figure 3. Indirectly Driving a Capacitive Load with DC Accuracy**

### Differential amplifier

The differential amplifier allows the subtraction of two input voltages or cancellation of a signal common the two inputs. It is useful as a computational amplifier in making a differential to single-end conversion or in rejecting a common mode signal. Figure 4. shown the differential amplifier using

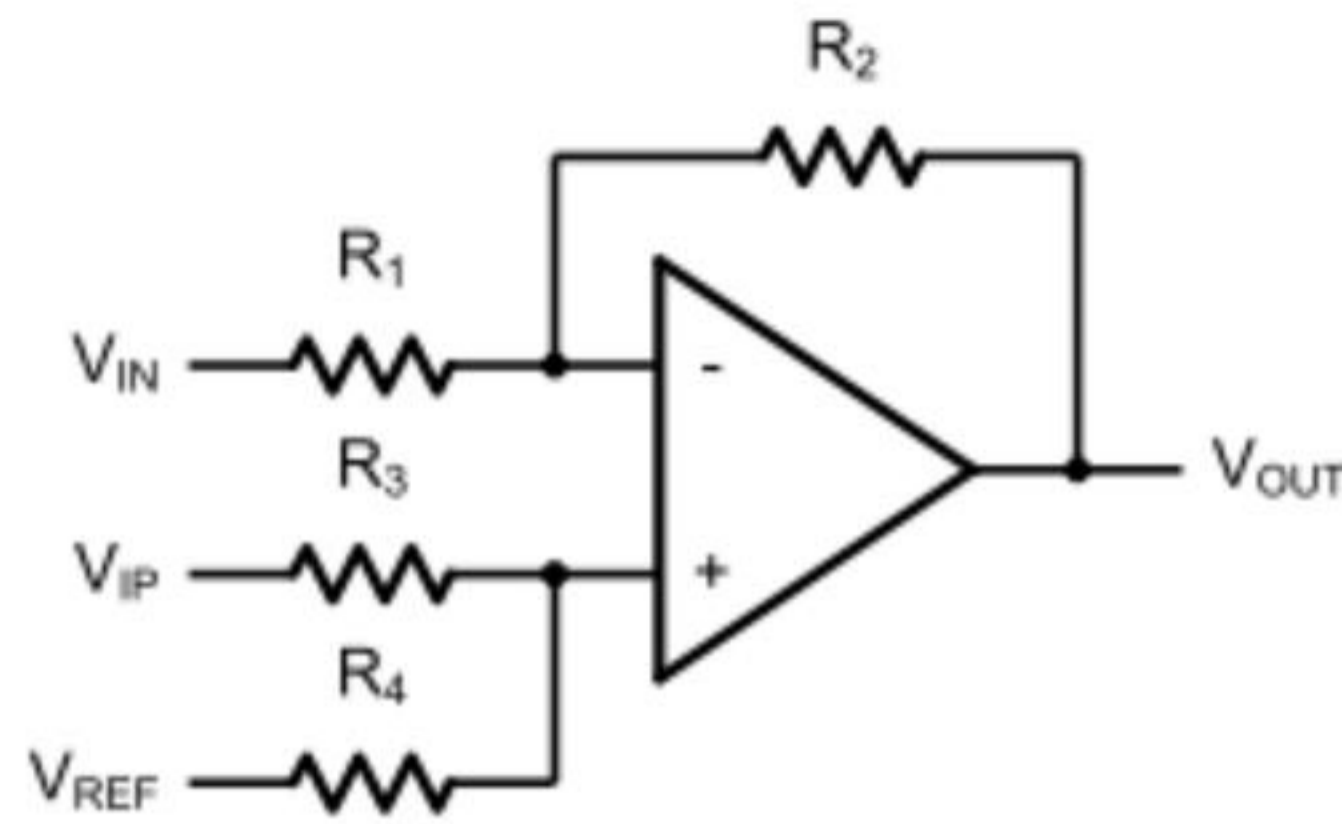

**Figure 4. Differential Amplifier**

$$V_{OUT} = \left(\frac{R_1+R_2}{R_3+R_4}\right) \frac{R_4}{R_1} V_{IN} - \frac{R_2}{R_1} V_{IP} + \left(\frac{R_1+R_2}{R_3+R_4}\right) \frac{R_3}{R_1} V_{REF}$$

If the resistor ratios are equal (i.e.  $R_1=R_3$  and  $R_2=R_4$ ), then

$$V_{OUT} = \frac{R_2}{R_1} (V_{IP} - V_{IN}) + V_{REF}$$

### Instrumentation Amplifier

The input impedance of the previous differential amplifier is set by the resistors  $R_1$ ,  $R_2$ ,  $R_3$ , and  $R_4$ . To maintain the high input impedance, one can use a voltage follower in front of each input as shown in the following two instrumentation amplifiers.

### Three-Op-Amp Instrumentation Amplifier

The dual TPV358 can be used to build a three-op-amp instrumentation amplifier as shown in Figure 5.

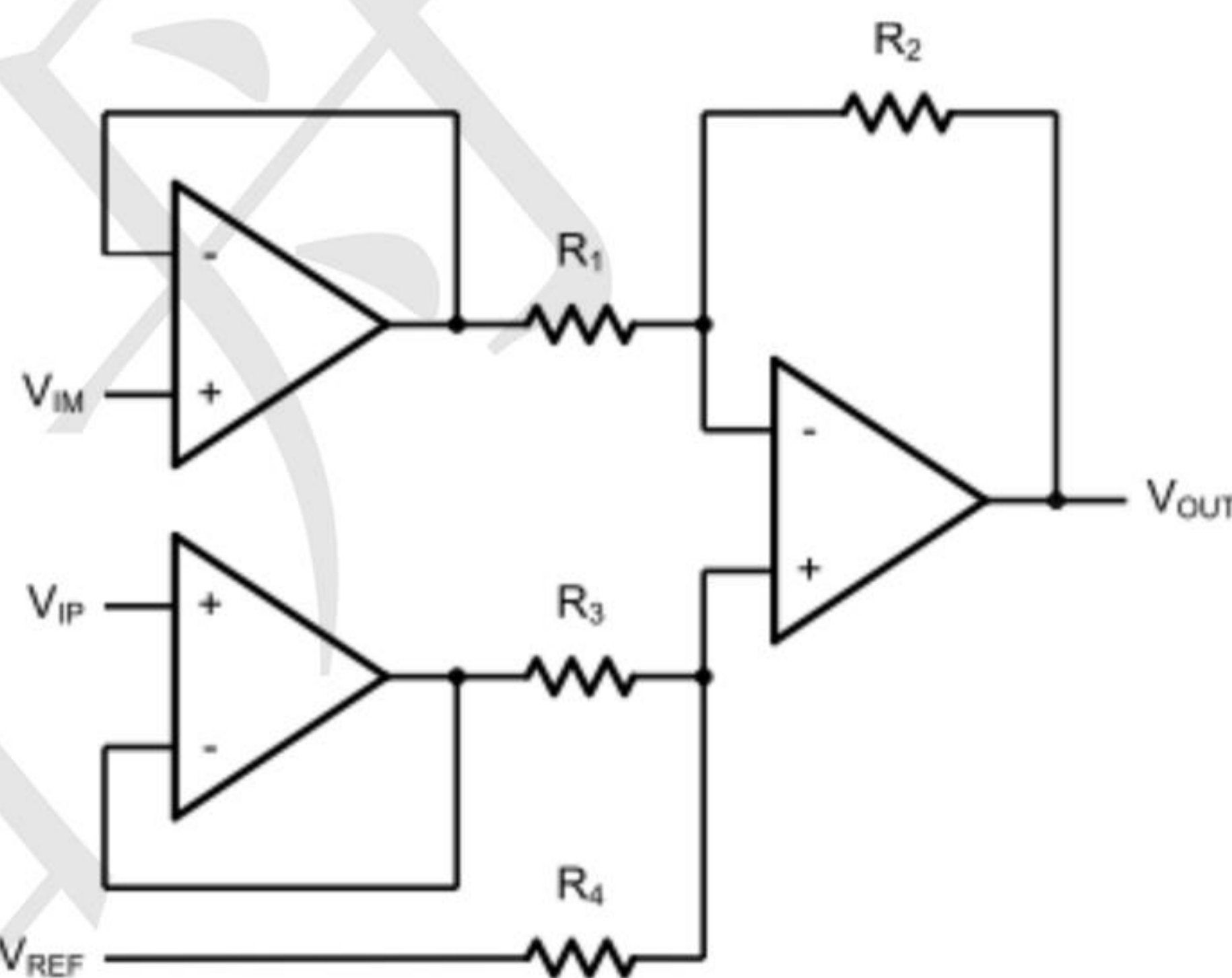

**Figure 5. Three-Op-Amp Instrumentation Amplifier**

The amplifier in Figure 5 is a high input impedance differential amplifier with gain of  $R_2/R_1$ . The two differential voltage followers assure the high input impedance of the amplifier.

$$V_o = \left(1 + \frac{R_4}{R_3}\right)(V_{IP} - V_{IN})$$

### Two-Op-Amp Instrumentation Amplifier

TPV358 can also be used to make a high input impedance two-op-amp instrumentation amplifier as shown in Figure 6.

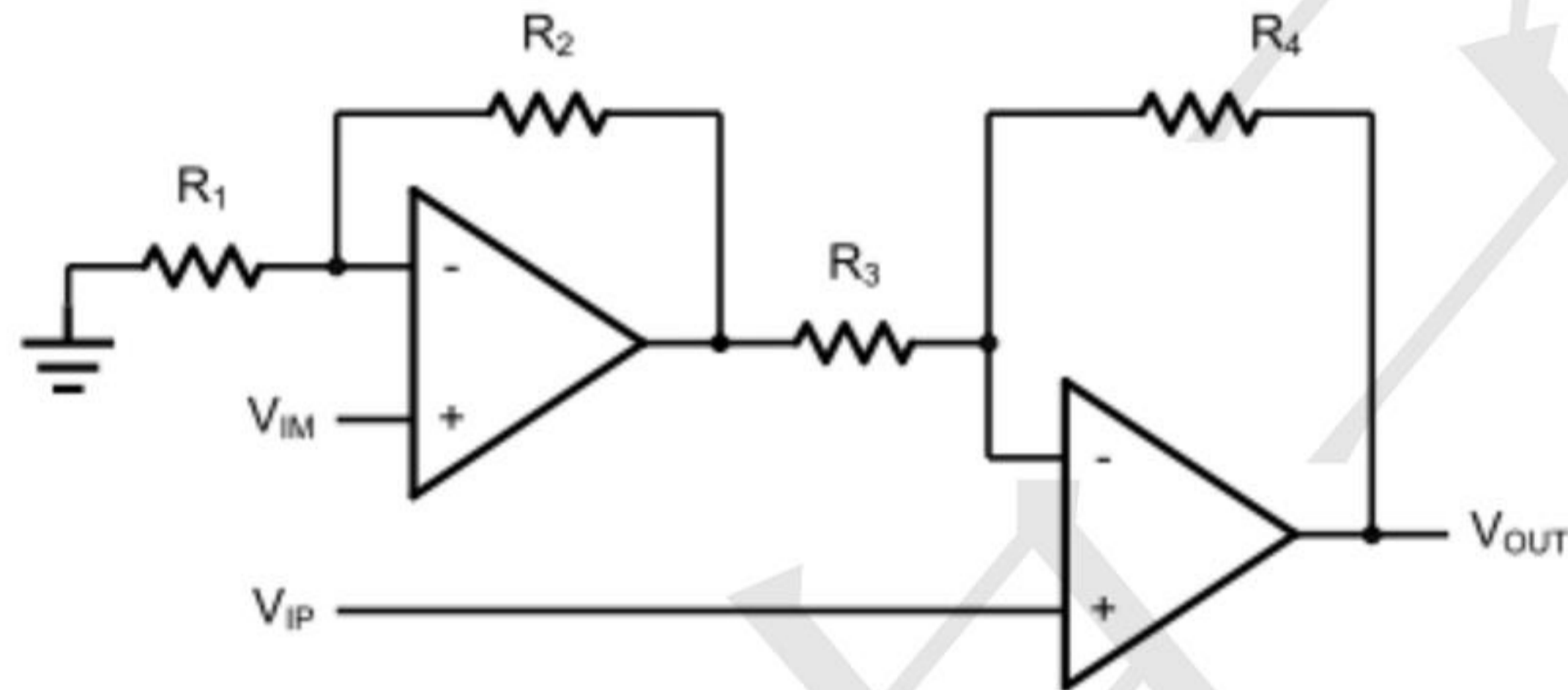
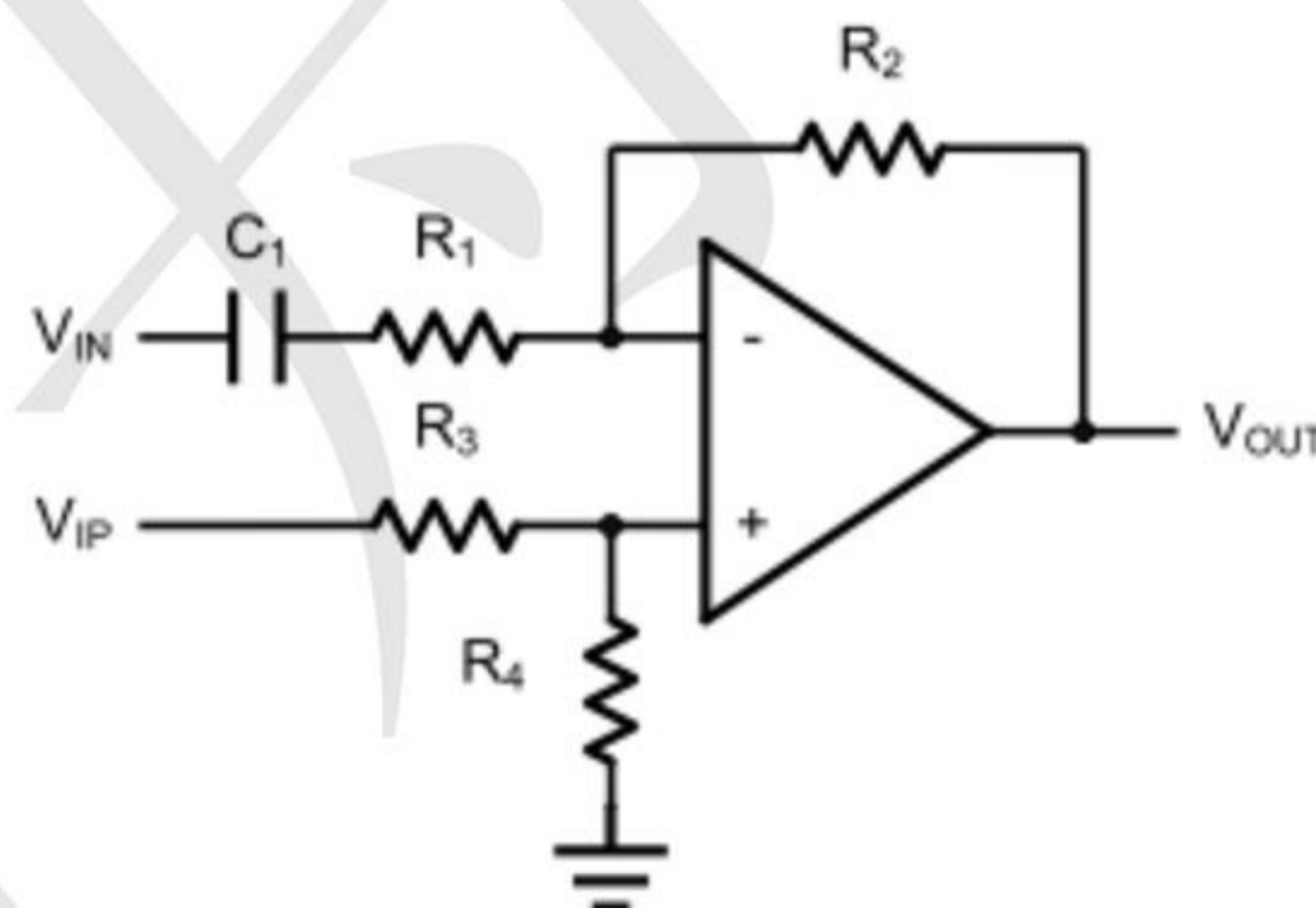

**Figure 6. Two-Op-Amp Instrumentation Amplifier**

Where  $R_1=R_3$  and  $R_2=R_4$ . If all resistors are equal, then  $V_o=2(V_{IP}-V_{IN})$

### Single-Supply Inverting Amplifier

The inverting amplifier is shown in Figure 6. The capacitor  $C_1$  is used to block the DC signal going into the AC signal source  $V_{IN}$ . The value of  $R_1$  and  $C_1$  set the cut-off frequency to  $f_c=1/(2\pi R_1 C_1)$ . The DC gain is defined by  $V_{OUT}=-\left(R_2/R_1\right)V_{IN}$



**Figure 7. Single Supply Inverting Amplifier**

### Low Pass Active Filter

The low pass active filter is shown in Figure 8. The DC gain is defined by  $-R_2/R_1$ . The filter has a -20dB/decade roll-off after its corner frequency  $f_c=1/(2\pi R_3 C_1)$ .

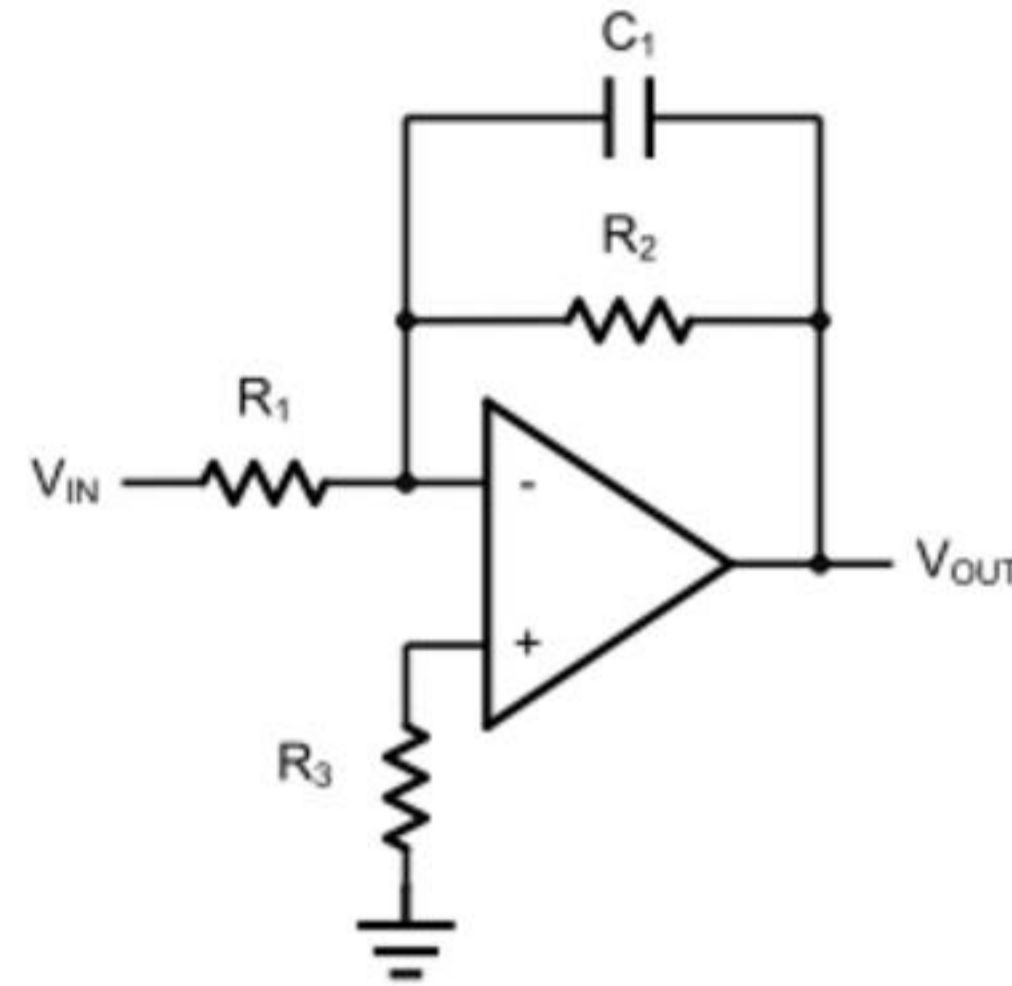

**Figure 8. Low Pass Active Filter**

**Sallen-Key 2nd Order Active Low-Pass Filter**

TPV358 can be used to form a 2nd order Sallen-Key active low-pass filter as shown in Figure 9. The transfer function from VIN to VOUT is given by

$$\frac{V_{OUT}}{V_{IN}}(S) = \frac{\frac{1}{C_1 C_2 R_1 R_2} A_{LP}}{S^2 + S \left( \frac{1}{C_1 R_1} + \frac{1}{C_1 R_2} + \frac{1}{C_2 R_2} - \frac{A_{LP}}{C_2 R_2} \right) + \frac{1}{C_1 C_2 R_1 R_2}}$$

Where the DC gain is defined by  $A_{LP} = 1 + R_3/R_4$ , and the corner frequency is given by

$$\omega_C = \sqrt{\frac{1}{C_1 C_2 R_1 R_2}}$$

The pole quality factor is given by

$$\frac{\omega_C}{Q} = \frac{1}{C_1 R_1} + \frac{1}{C_1 R_2} + \frac{1}{C_2 R_2} - \frac{A_{LP}}{C_2 R_2}$$

Let  $R_1 = R_2 = R$  and  $C_1 = C_2 = C$ , the corner frequency and the pole quality factor can be simplified as below

$$\omega_C = \frac{1}{CR}$$

And  $Q = 2 - R_3/R_4$

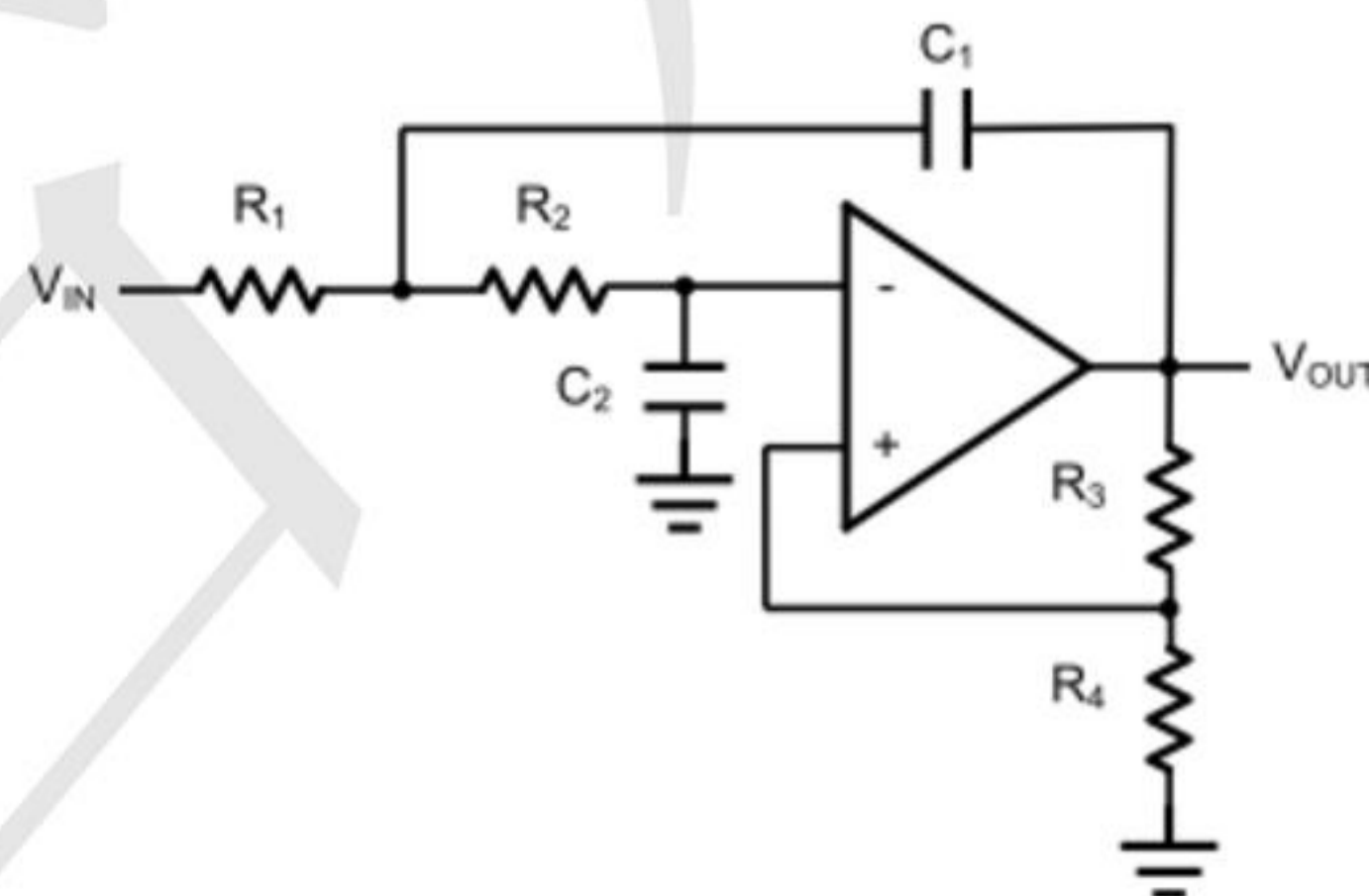
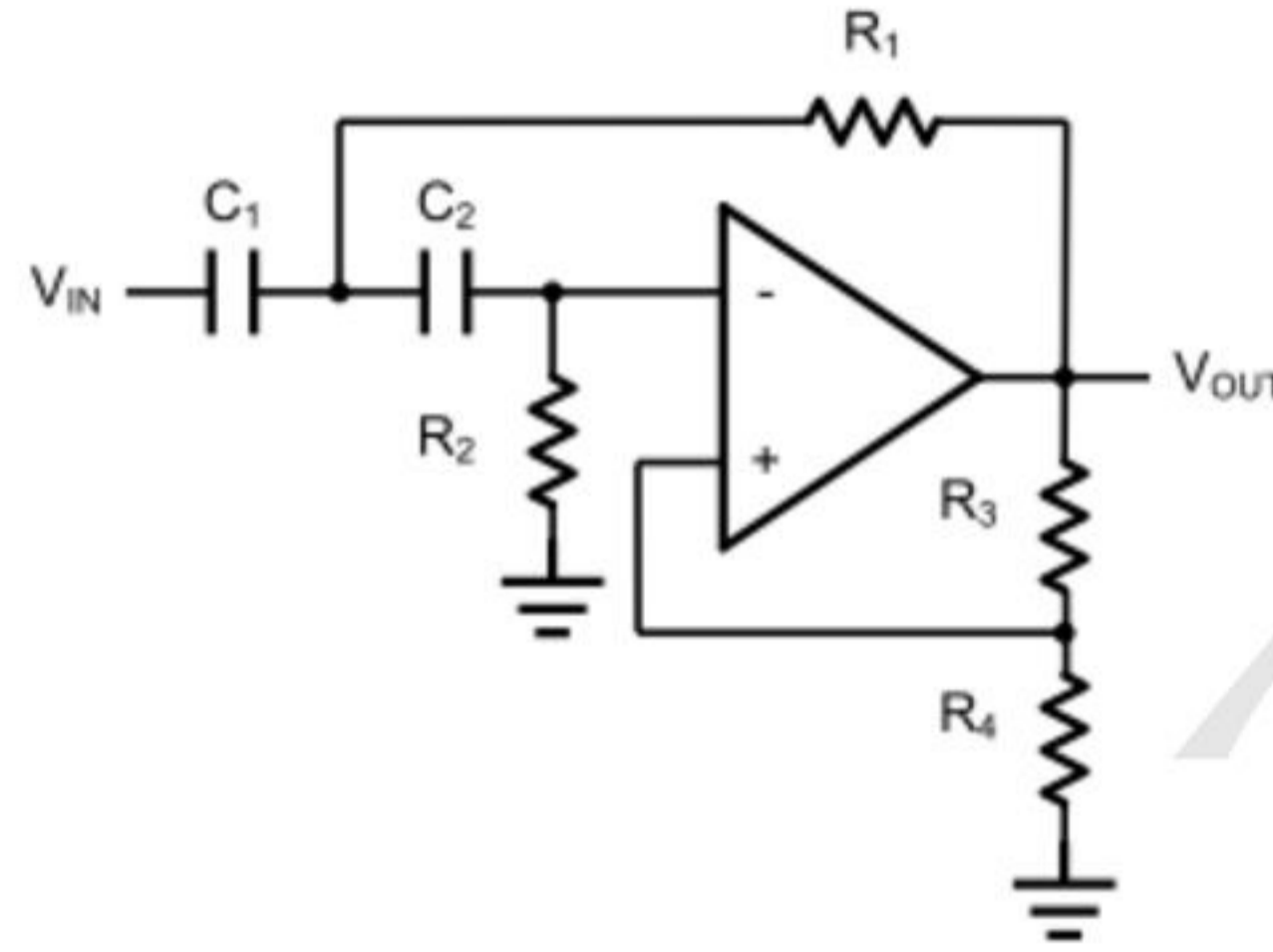

**Figure 9. Sallen-Key 2nd Order Active Low-Pass Filter**



**Sallen-Key 2nd Order high-Pass Active Filter**

The 2nd order Sallen-key high-pass filter can be built by simply interchanging those frequency selective components R1, R2, C1, and C2 as shown in Figure 10.



**Figure 10. Sallen-Key 2nd Order Active High-Pass Filter**

$$\frac{V_{OUT}}{V_{IN}}(S) = \frac{S^2 A_{HP}}{S^2 + S\left(\frac{1}{C_1 R_1} + \frac{1}{C_2 R_2} + \frac{1 - A_{HP}}{C_1 R_1}\right) + \frac{1}{C_1 C_2 R_1 R_2}}$$

Where  $A_{HP} = 1 + R_3/R_4$

**Typical characteristics**

At  $T_A=+25^{\circ}\text{C}$ ,  $R_L=100\text{ k}\Omega$  connected to  $V_S/2$  and  $V_{OUT}=V_S/2$ , unless otherwise noted.

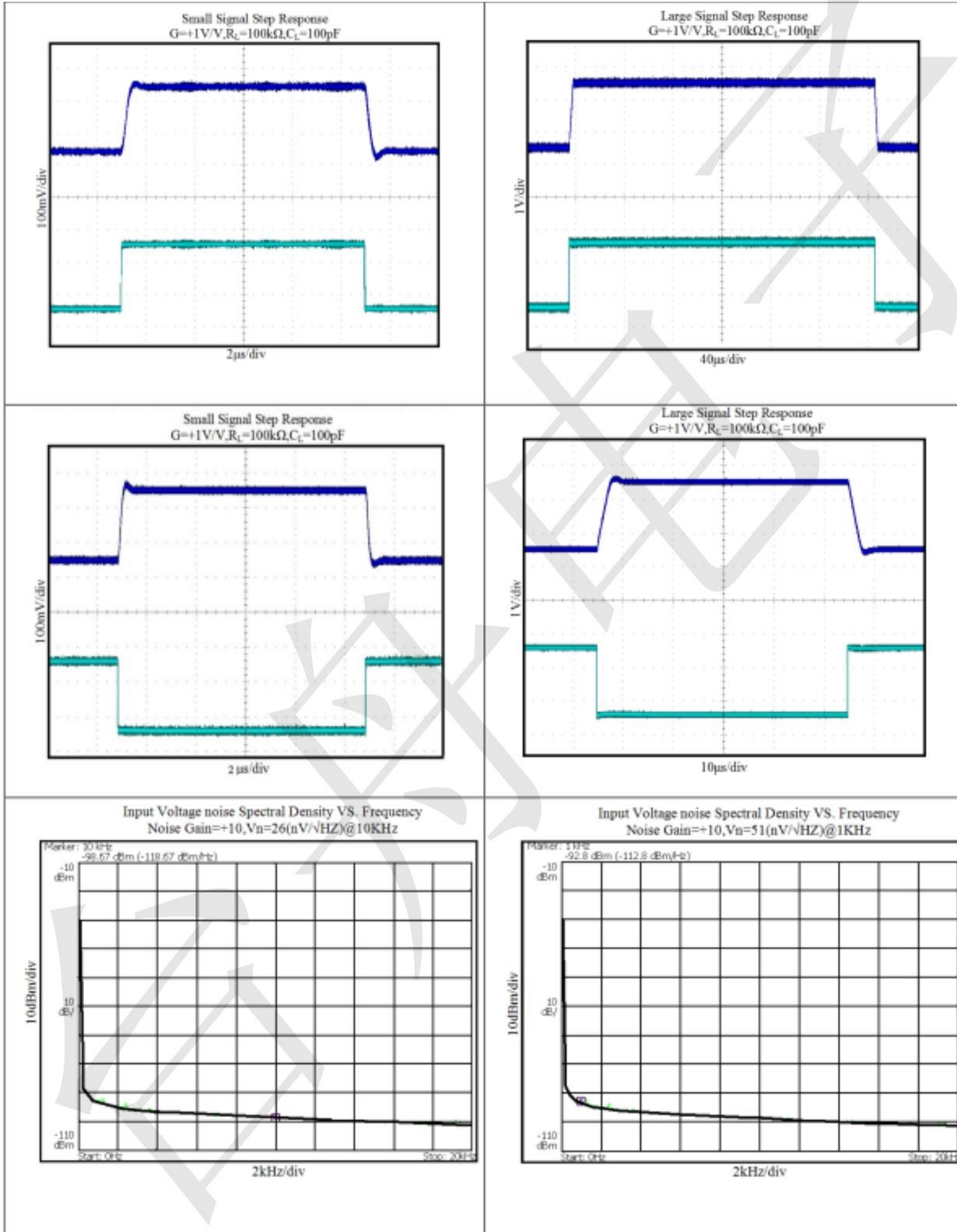

At  $T_A=+25^\circ\text{C}$ ,  $R_L=100\text{ k}\Omega$  connected to  $V_S/2$  and  $V_{OUT}=V_S/2$ , unless otherwise noted.

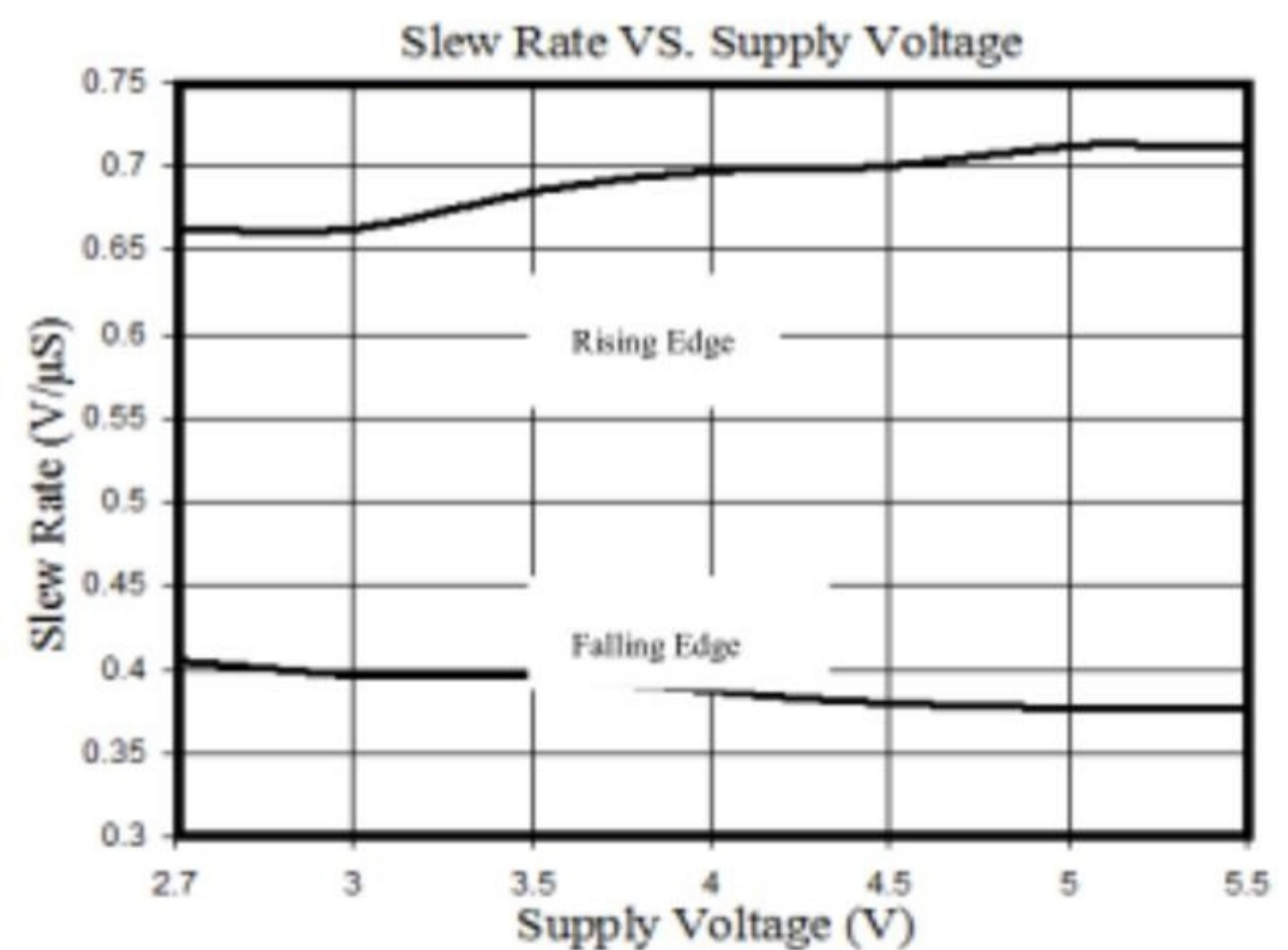
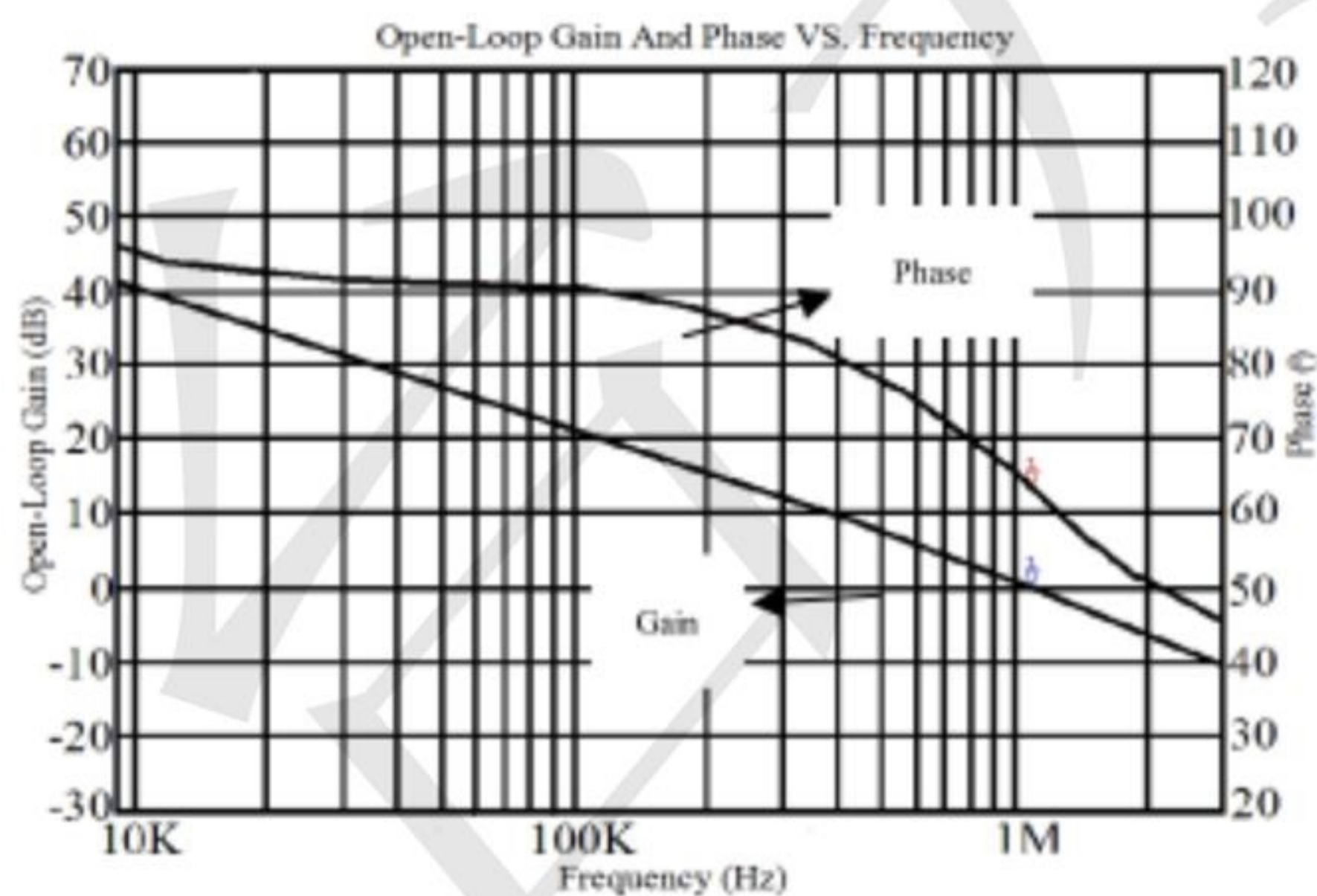
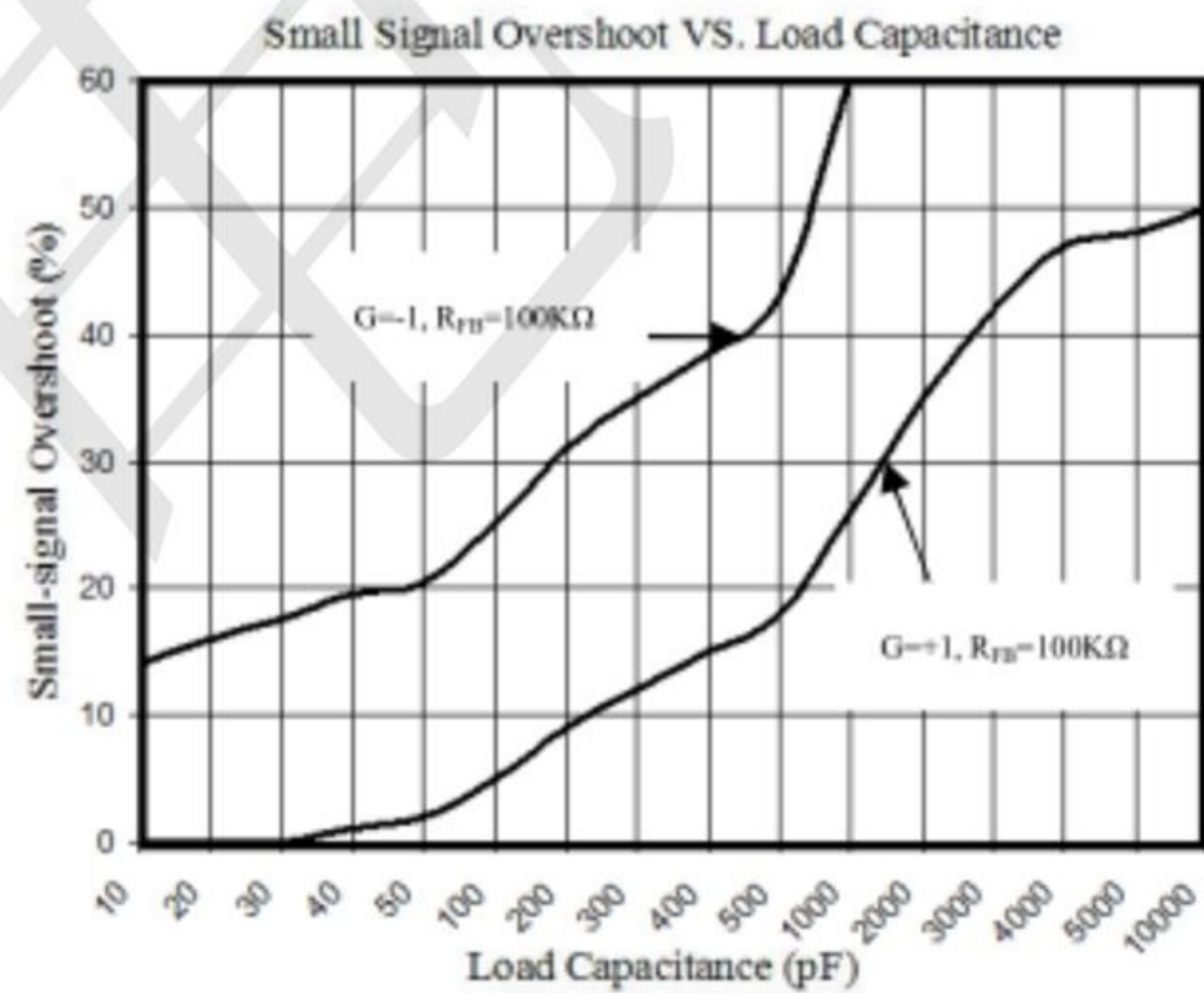
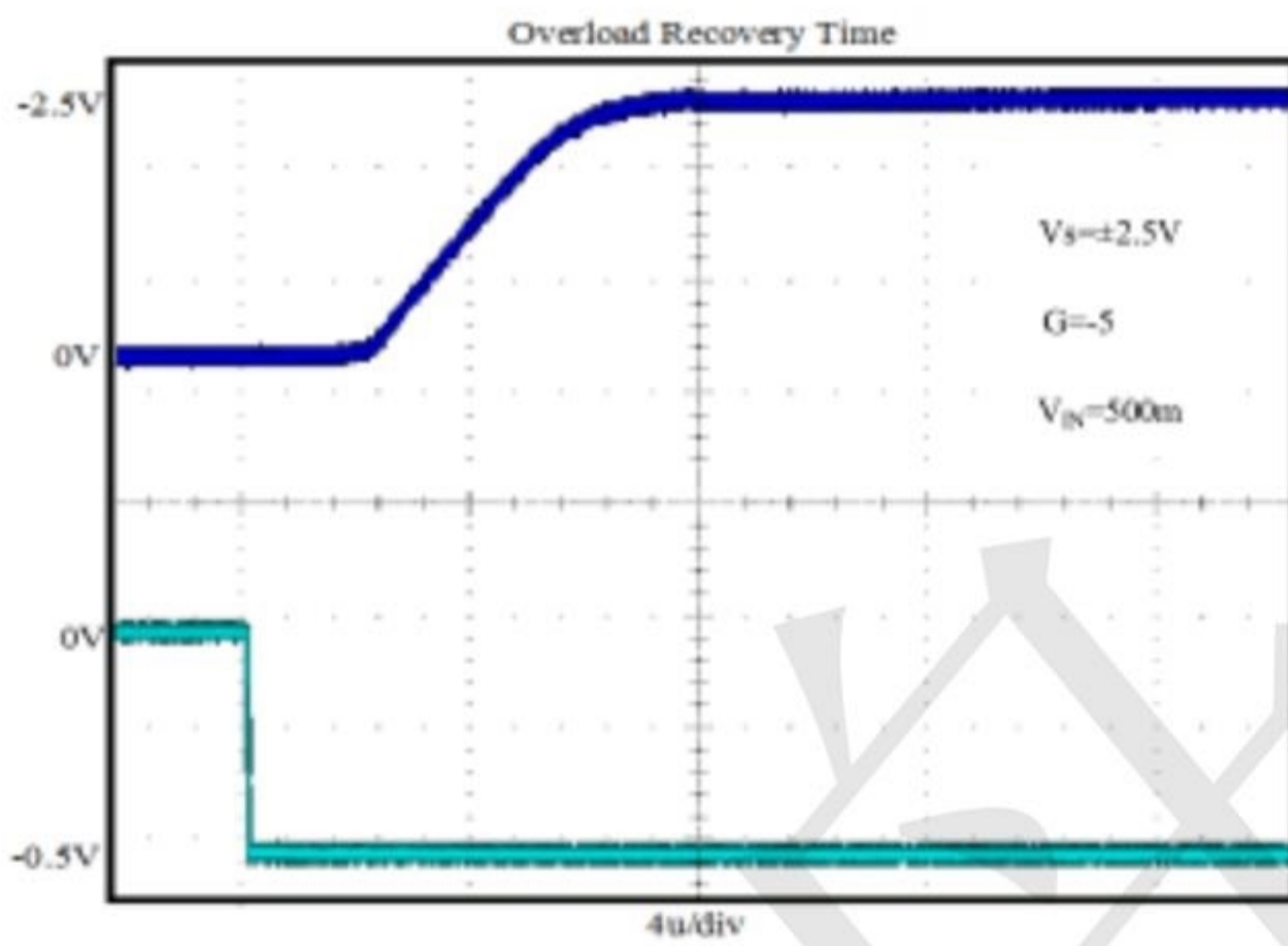
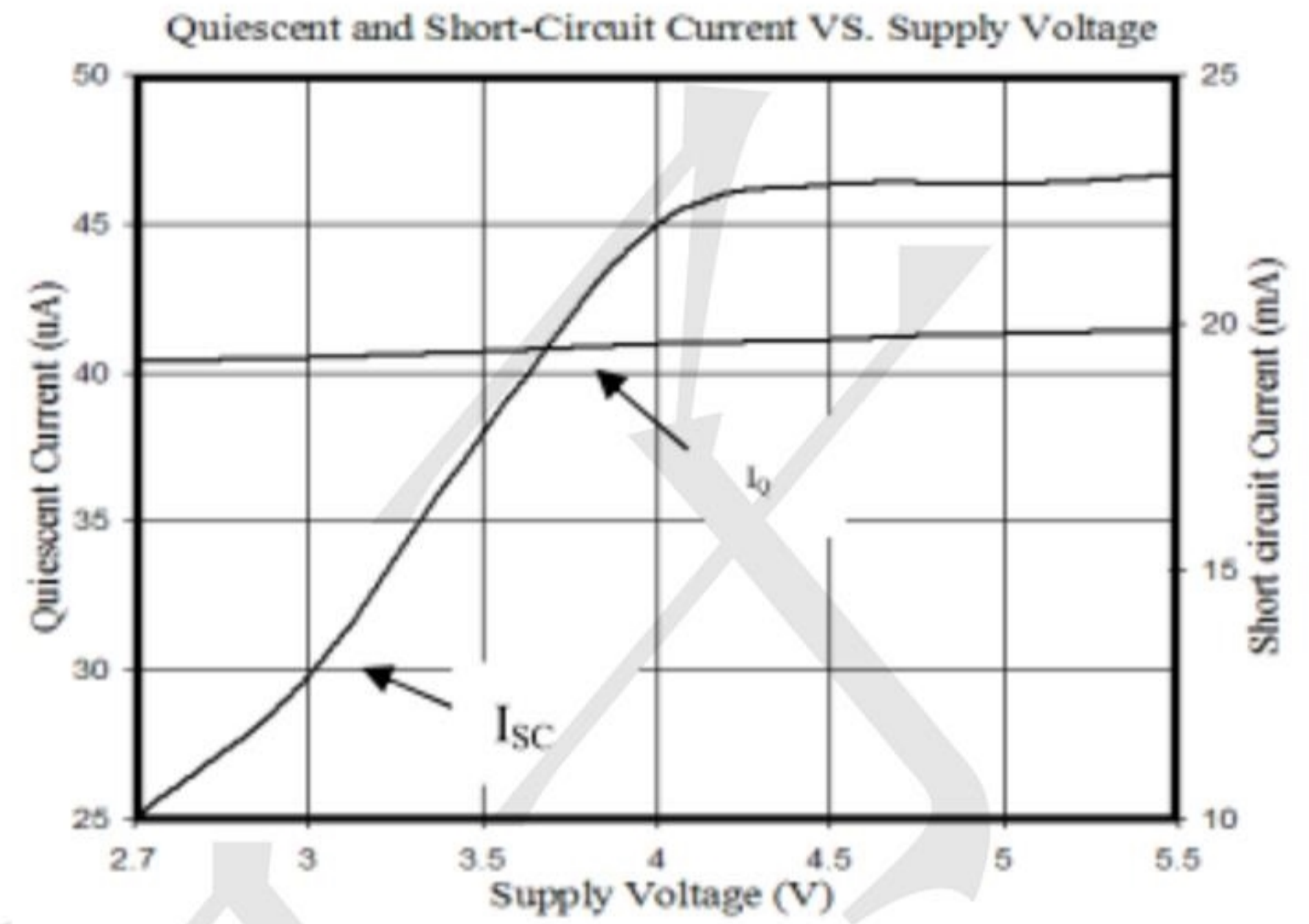
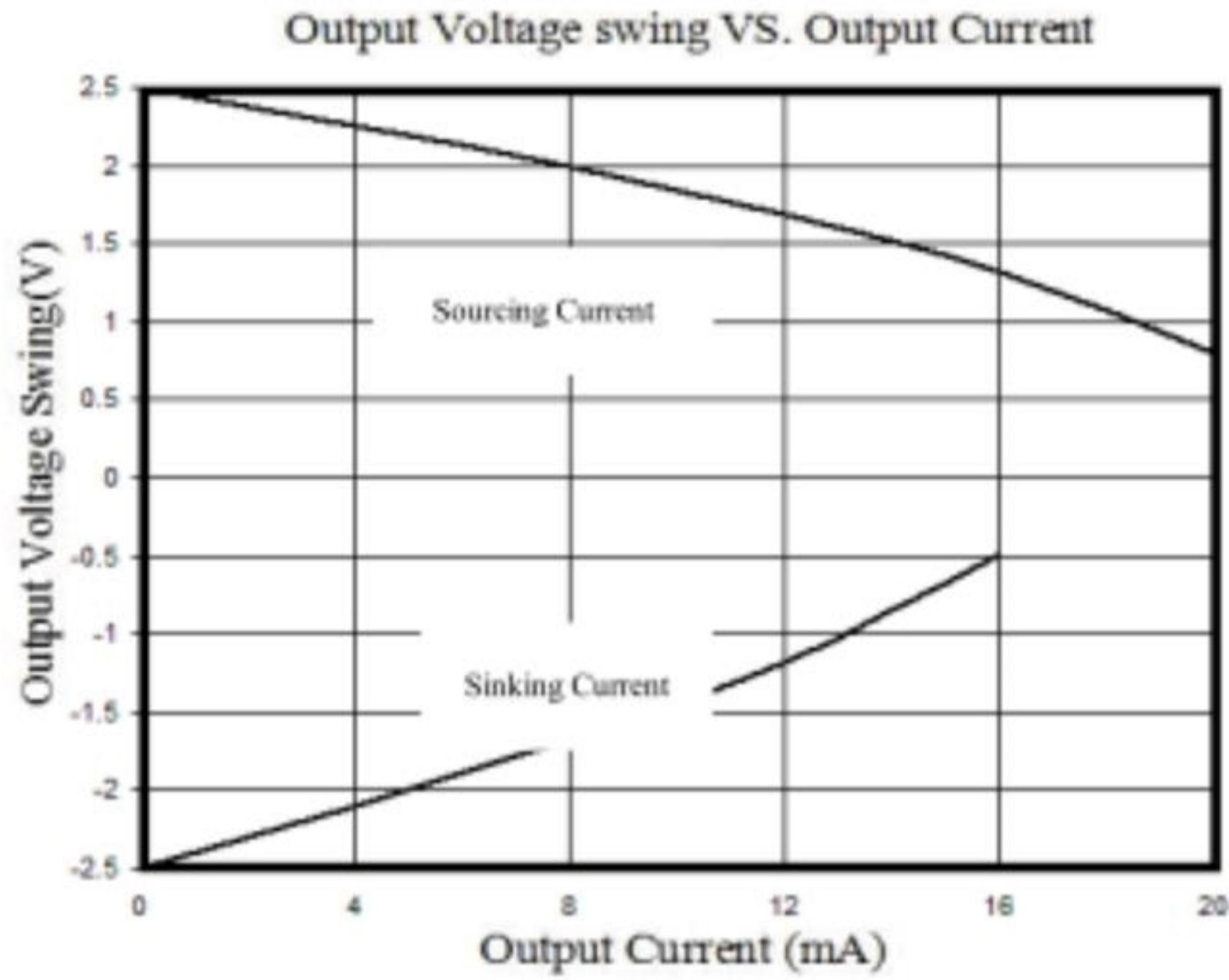

**Package Information**  
SOP-8L

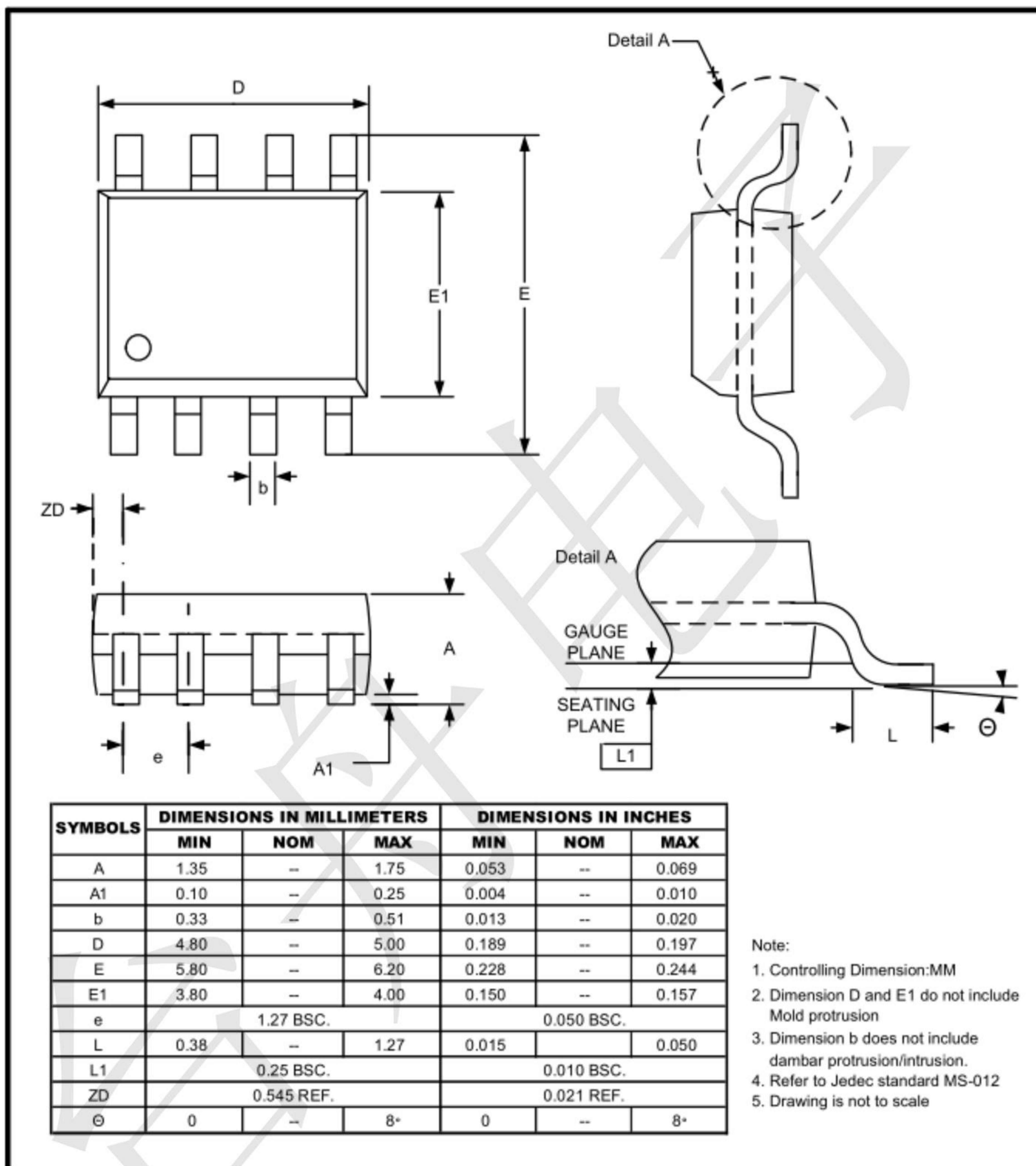

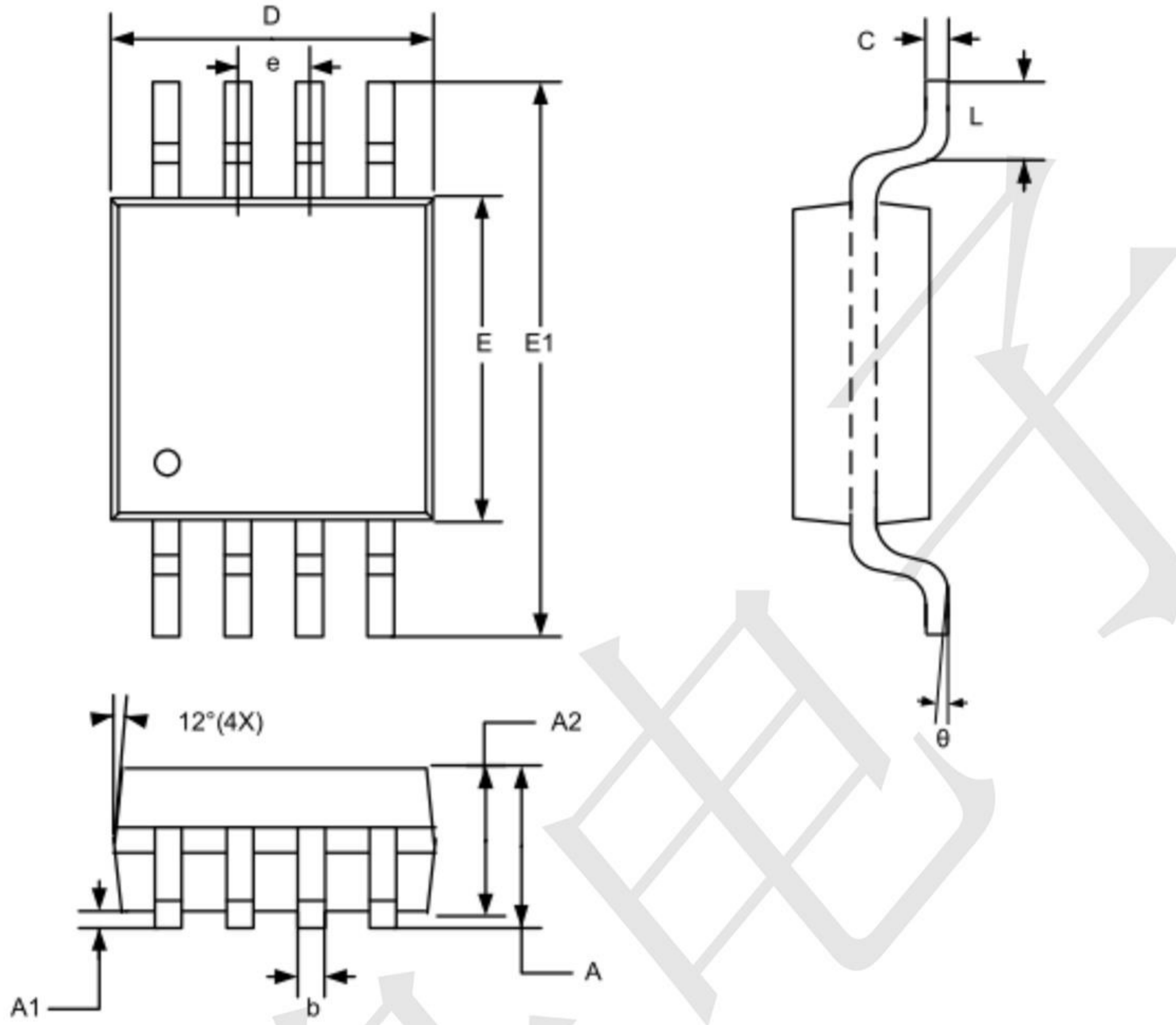

SYMBOLS	DIMENSIONS IN MILLIMETERS			DIMENSIONS IN INCHES		
	MIN	NOM	MAX	MIN	NOM	MAX
A	--	--	1.10	--	--	0.043
A1	0.05	--	0.15	0.002	--	0.006
A2	0.75	0.85	0.95	0.030	0.033	0.037
b	0.25	--	0.40	0.010	--	0.016
C	0.13	--	0.23	0.005	--	0.009
D	2.90	3.00	3.10	0.114	0.118	0.122
E	2.90	3.00	3.10	0.114	0.118	0.122
E1	4.90 BSC			0.193 BSC		
e	0.65 BSC			0.026 BSC		
L	--	--	0.55	--	--	0.022
θ	0	--	7°	0	--	7°

- Note:  
 1. Controlling Dimension:MM  
 2. Dimension D and E1 do not include Mold protrusion  
 3. Refer to Jedec standard MO187  
 4. Drawing is not to scale

## X-ON Electronics

Largest Supplier of Electrical and Electronic Components

*Click to view similar products for [Operational Amplifiers - Op Amps](#) category:*

*Click to view products by [TECH PUBLIC](#) manufacturer:*

Other Similar products are found below :

[430227FB](#) [AZV831KTR-G1](#) [UPC451G2-A](#) [UPC824G2-A](#) [LT1678IS8](#) [042225DB](#) [058184EB](#) [UPC822G2-A](#) [UPC258G2-A](#)  
[NCS5651MNTXG](#) [NCV33202DMR2G](#) [NJM324E](#) [NTE925](#) [5962-9080901MCA\\*](#) [AP4310AUMTR-AG1](#) [HA1630D02MMEL-E](#)  
[HA1630S01LPEL-E](#) [SCY33178DR2G](#) [NJU77806F3-TE1](#) [NCV5652MUTWG](#) [NCV20034DR2G](#) [LM2902EDR2G](#) [NTE778S](#) [NTE871](#)  
[NTE924](#) [NTE937](#) [MCP6V16UT-E/OT](#) [MCP6V17T-E/MS](#) [MCP6V19T-E/ST](#) [SCY6358ADR2G](#) [LTC2065IUD#PBF](#) [NCS20282FCTTAG](#)  
[LM4565FVT-GE2](#) [EL5420CRZ-T7A](#) [TSV791IYLT](#) [TSV772IQ2T](#) [TLV2772QPWR](#) [NJM2100M-TE1](#) [NJM4556AM-TE1](#) [MCP6487-E/SN](#)  
[MCP6487-E/MS](#) [AS324MTR-E1](#) [AS358MMTR-G1](#) [MCP6232T-EMNY](#) [MCP662-E/MF](#) [TLC081AIP](#) [TLC082AIP](#) [TLE2074ACDW](#)  
[TLV07IDR](#) [TLV2170IDGKT](#)