

Features

- Low on-resistance
- ESD protected gate up to 2kV HBM
- High-speed switching
- Drive circuits can be simple
- Parallel use is easy

Shipping Quantity

- 3000pcs / Tape & Reel

Typical Applications

- N-channel enhancement mode effect transistor
- Switching application

Mechanical Data

- Case: SOT-323
- Molding Compound, UL Flammability Classification Rating 94V-0
- Terminals: Matte Tin Plated Leads, Solderable Per MIL-STD-202, Method 208

SOT-323

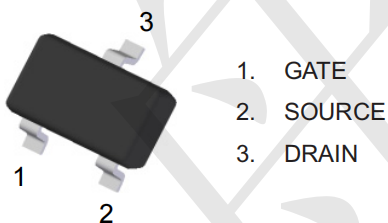

Circuit Diagram

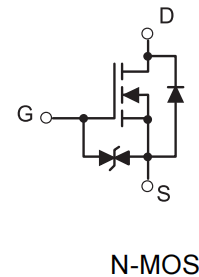

Marking: 72K c

Absolute Maximum Ratings (Tamb=25°C unless otherwise specified)

Parameter	Symbol	Value	Units
Drain-Source Voltage	V_{DSS}	60	V
Gate -Source Voltage	V_{GSS}	±20	V
Continuous Drain Current	I_D	300	mA
Pulsed Drain Current ($t_p = 10\mu s$)	I_{DM}	2000	mA
Single Pulse Avalanche Energy ²	E_{AS}	0.11	mJ
Power Dissipation	SOT-323	P_D	0.25 W

**Thermal Characteristics**

Parameter	Symbol	Limits	Unit
Thermal Resistance Junction to Ambient Air	$R_{\theta JA}$	500	°C/W
Thermal Resistance Junction to Lead	$R_{\theta JL}$	313	
Thermal Resistance Junction to Case	$R_{\theta JC}$	261	
Operating Junction Temperature Range	T_J	-55 to +150	°C
Storage Temperature Range	T_{STG}	-55 to +150	°C

Electrical Characteristics ($T_A=25^\circ\text{C}$ unless otherwise specified)

Symbol	Parameter	Test conditions	MIN	TYP	MAX	UNIT
OFF Characteristics						
V_{DSS}	Drain-Source Breakdown Voltage	$V_{GS} = 0V, I_D = 250\mu A$	60	-	-	V
I_{DSS}	Drain to Source Leakage Current	$V_{DS} = 60V, V_{GS} = 0V$	-	-	1	μA
I_{GSS}	Gate-body Leakage	$V_{GS} = \pm 20V, V_{DS} = 0V$	-	-	± 10	μA
ON Characteristics						
$R_{DS(ON)}$	Drain-Source On-resistance *1	$V_{GS} = 5V, I_D = 0.05A$	-	1.5	3	Ω
		$V_{GS} = 4.5V, I_D = 0.5A$	-	1.8	4	
		$V_{GS} = 10V, I_D = 0.5A$	-	1.45	2.5	
$V_{GS(TH)}$	Gate Threshold Voltage	$V_{DS} = V_{GS}, I_D = 250\mu A$	1	1.5	2.5	V
R_G	Gate Resistance	$V_{GS} = 0V, f = 1.0MHz$	-	39	-	Ω
Dynamic Characteristics						
C_{ISS}	Input Capacitance	$V_{GS} = 0V$	-	47.2	-	pF
C_{OSS}	Output Capacitance	$V_{DS} = 20V$	-	7.3	-	
C_{RSS}	Reverse Transfer Capacitance	$f = 1.0MHz$	-	4.7	-	
Switching Characteristics						
$t_{d(on)}$	Turn-on Delay Time *3	$V_{DD} = 30V, I_D = 0.2A$ $V_{GS} = 10V, R_G = 25\Omega$ $R_L = 150\Omega$	-	6	-	nS
t_r	Turn-on Rise Time *3		-	5	-	
$t_{d(off)}$	Turn-Off Delay Time *3		-	25	-	
t_f	Turn-Off Fall Time *3		-	15	-	
Q_G	Total Gate-Charge	$V_{DS} = 10V$	-	0.44	-	nC
Q_{GS}	Gate to Source Charge	$V_{GS} = 4.5V$	-	0.14	-	nC
Q_{GD}	Gate to Drain (Miller) Charge	$I_D = 0.2A$	-	0.2	-	nC
Source-Drain Diode Characteristics						
V_{SD}	Diode Forward Voltage *1	$I_S = 0.3A, V_{GS} = 0V$	-	0.85	1.2	V
I_S	Diode Continuous Forward Current	$T_C = 25^\circ\text{C}$	-	-	0.3	A



Typical Performance Characteristics ($T_A=25^\circ\text{C}$ unless otherwise Specified)

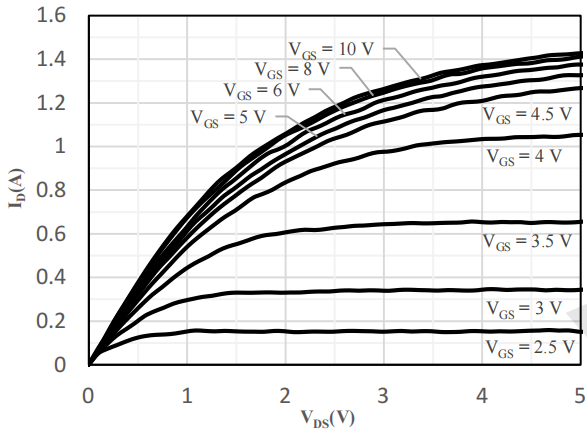

Fig 1 Typical Output Characteristics

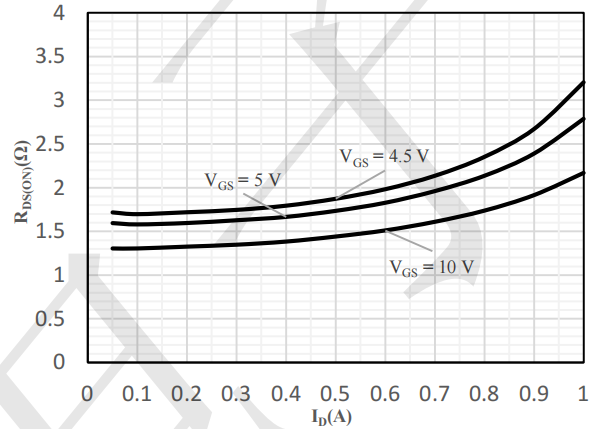

Fig 2 On-Resistance vs. Drain Current and Gate Voltage

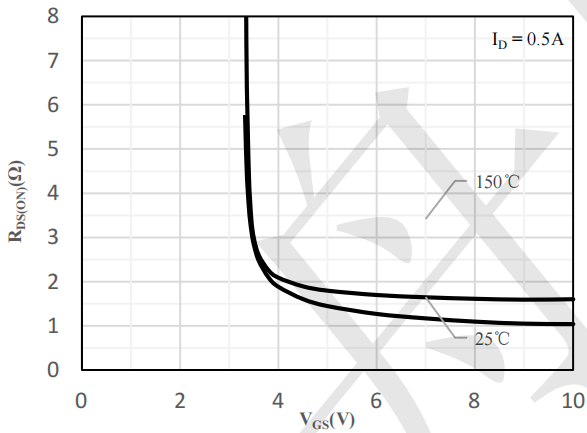

Fig 3 On-Resistance vs. Gate-Source Voltage

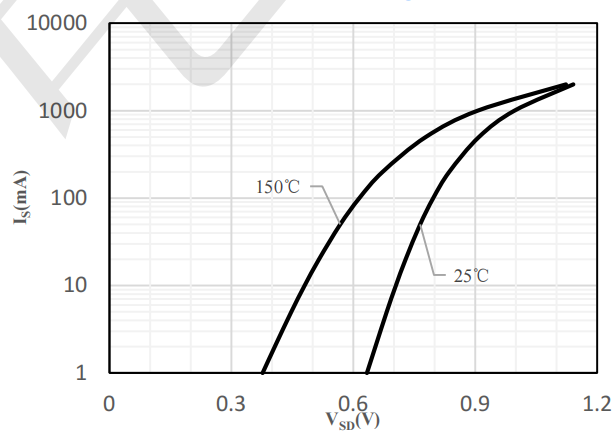

Fig 4 Body-Diode Characteristics

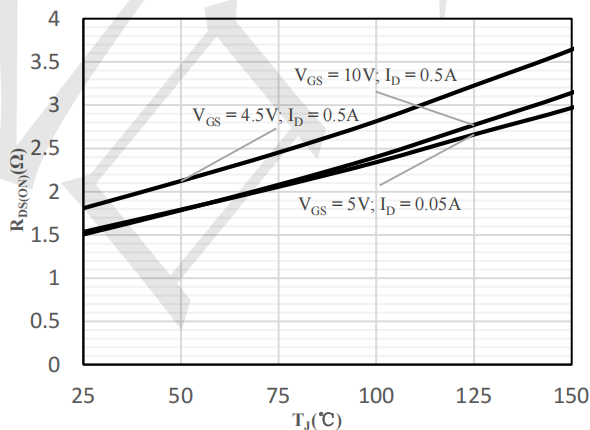

Fig 5 On-Resistance vs. Junction Temperature

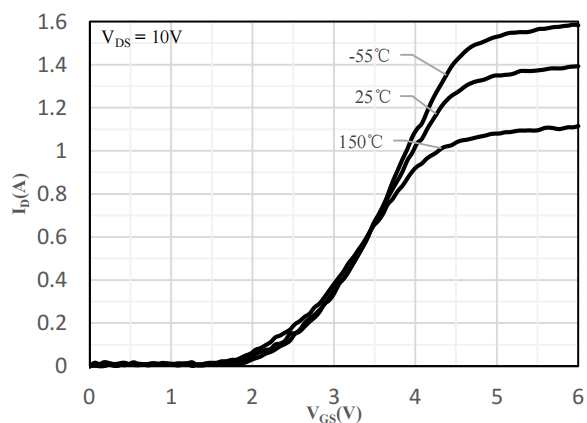

Fig 6 Transfer Characteristics



Typical Performance Characteristics ($T_A=25^\circ\text{C}$ unless otherwise Specified)

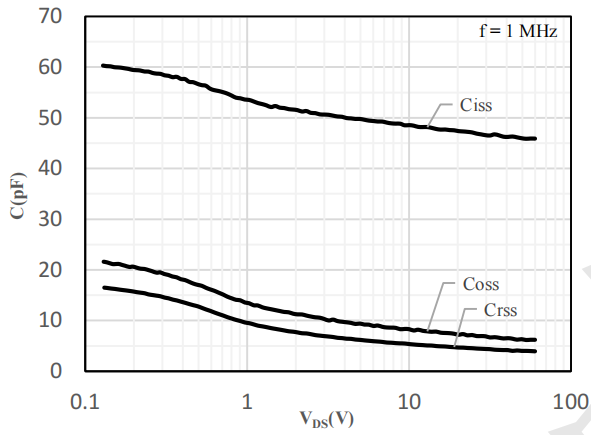

Fig 7 Capacitance Characteristics

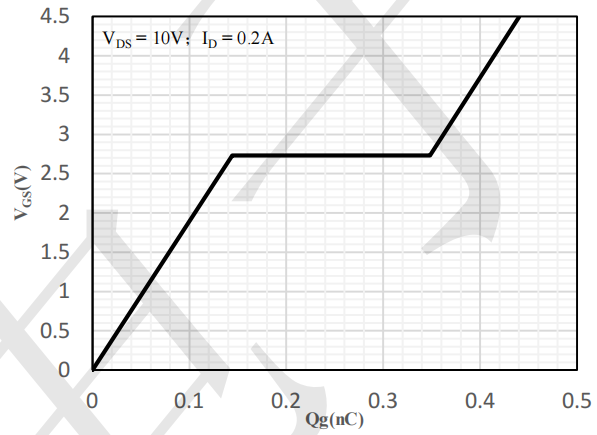

Fig 8 Gate-Charge Characteristics

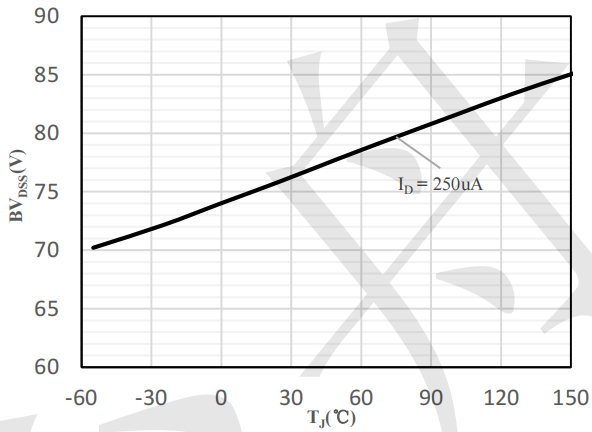

Fig 9 Breakdown Voltage vs. Junction Temperature

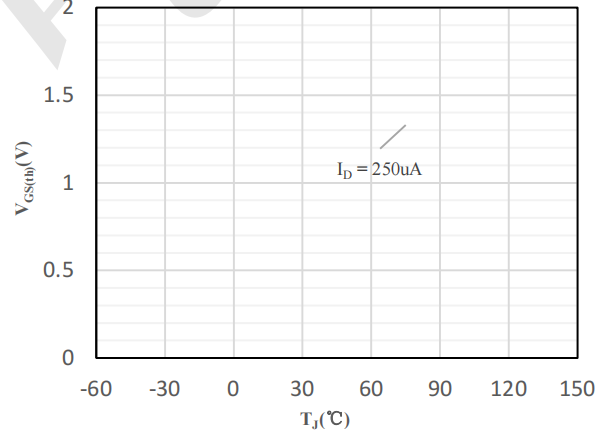
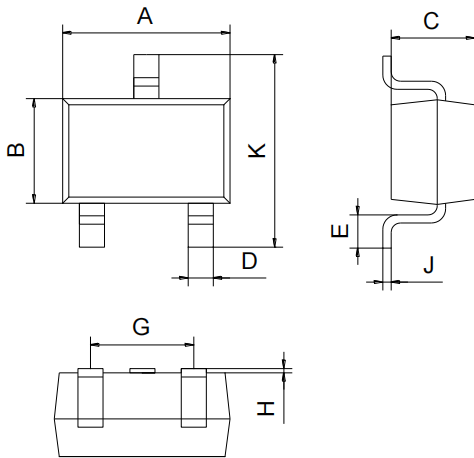

Fig 10 $V_{GS(th)}$ vs. Junction Temperature



Outline Drawing - SOT323(unit: mm)



SOT-323		
Dimension	Min.	Max.
A	2.00	2.20
B	1.15	1.35
C	0.90	1.10
D	0.15	0.35
E	0.25	0.40
G	1.20	1.40
H	0.02	0.10
J	0.05	0.15
K	2.20	2.40

Mounting Pad Layout-SOT323(unit: mm)

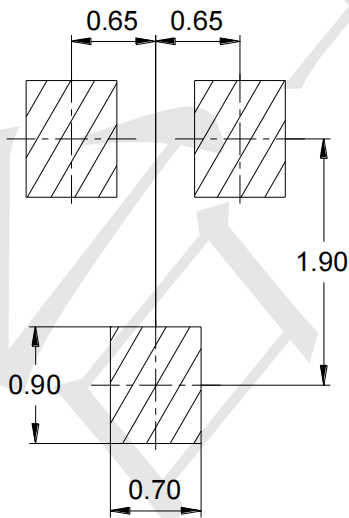

X-ON Electronics

Largest Supplier of Electrical and Electronic Components

Click to view similar products for [MOSFET](#) category:

Click to view products by [TECH PUBLIC](#) manufacturer:

Other Similar products are found below :

[IRFD120](#) [JANTX2N5237](#) [BUK455-60A/B](#) [MIC4420CM-TR](#) [VN1206L](#) [NDP4060](#) [SI4482DY](#) [IPS70R2K0CEAKMA1](#) [SQD23N06-31L-GE3](#)
[TK16J60W,S1VQ\(O](#) [2SK2614\(TE16L1,Q\)](#) [DMN1017UCP3-7](#) [DMN1053UCP4-7](#) [SQJ469EP-T1-GE3](#) [NTE2384](#) [DMC2700UDMQ-7](#)
[DMN2080UCB4-7](#) [DMN61D9UWQ-13](#) [US6M2GTR](#) [DMN31D5UDJ-7](#) [DMP22D4UFO-7B](#) [DMN1006UCA6-7](#) [DMN16M9UCA6-7](#)
[STF5N65M6](#) [IRF40H233XTMA1](#) [STU5N65M6](#) [DMN6022SSD-13](#) [DMN13M9UCA6-7](#) [DMTH10H4M6SPS-13](#) [DMN2990UFB-7B](#)
[IPB80P04P405ATMA2](#) [2N7002W-G](#) [MCAC30N06Y-TP](#) [MCQ7328-TP](#) [NTMC083NP10M5L](#) [NVMFS2D3P04M8LT1G](#) [BXP7N65D](#)
[BXP4N65F](#) [AOL1454G](#) [WMJ80N60C4](#) [BXP2N20L](#) [BXP2N65D](#) [BXT1150N10J](#) [BXT1700P06M](#) [TSM60NB380CP](#) [ROG](#) [RQ7L055BGTCR](#)
[DMNH15H110SK3-13](#) [SLF10N65ABV2](#) [BSO203SP](#) [BSO211P](#)