

Features

- 100 μ A Current at no Load
- $\pm 2\%$ Output Accuracy
- 700mA Output Current
- Current Limit Protection

Applications

- Industrial Controls
- Home Automation
- Modules (Wireless, Camera, etc.)
- Portable, Battery Powered Equipment

PIN CONFIGURATION

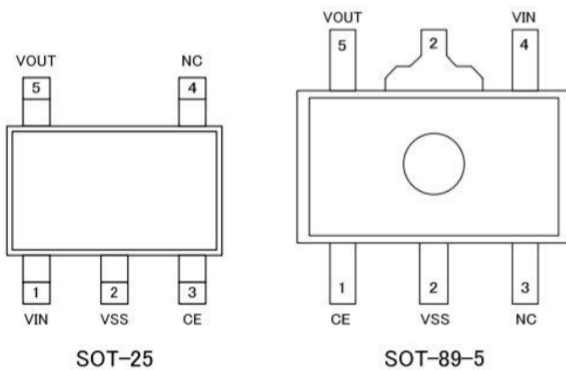

Pin Number		Pin Name	Pin Function
SOT23-5	SOT89-5		
1	4	VIN	Input of Supply Voltage
2	2	GND (VSS)	Ground
3	1	EN (CE)	Enable Control Input
4	3	NC	No Internal Connection
5	5	VOUT	Output of the Regulator

Ordering Information

XC6227C301MR

PACKAGE TYPE
MR: SOT23-5
PR: SOT89-5

OUTPUT VOLTAGE

12: 1.2V
15: 1.5V
18: 1.8V
25: 2.5V
30: 3.0V
33: 3.3V
50: 5.0V

MARKING DIAGRAMS

XC6227C121MR Marking: 3EC07

XC6227C181MR Marking: 3EL07

XC6227C301MR Marking: 3H307

Absolute Maximum Ratings

over operating free-air temperature range (unless otherwise noted)

		MIN	MAX	UNIT
V _{IN}	Continuous input voltage range	-0.3	6.5	V
V _{OUT}	Output voltage range	-0.3	6.5	
EN	EN pin voltage range	-0.3	6.5	
I _{OUT}	Output pin current	Internally limited		mA
Temperature	Operating junction, T _J	-40	150	°C
	Storage, T _{stg}	-55	150	

ESD Ratings

			VALUE	UNIT
V (ESD)	Electrostatic discharge	Human body model (HBM)	±2000	V
		Machine Model (MM)	±200	

BLOCK DIAGRAM

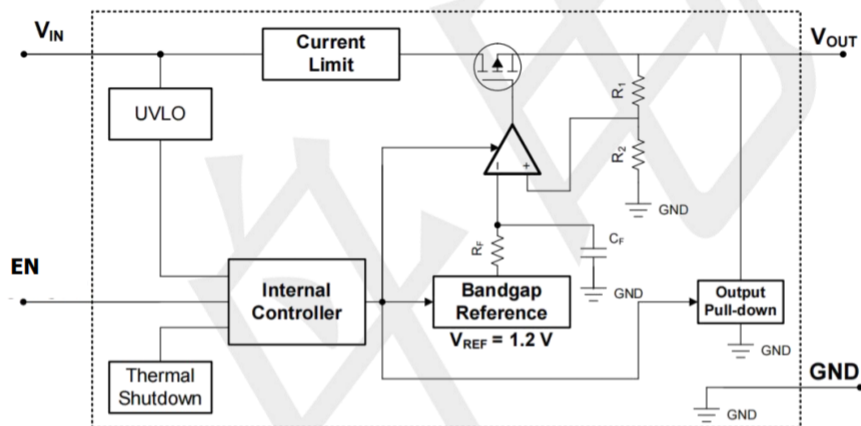

Typical Application Circuit

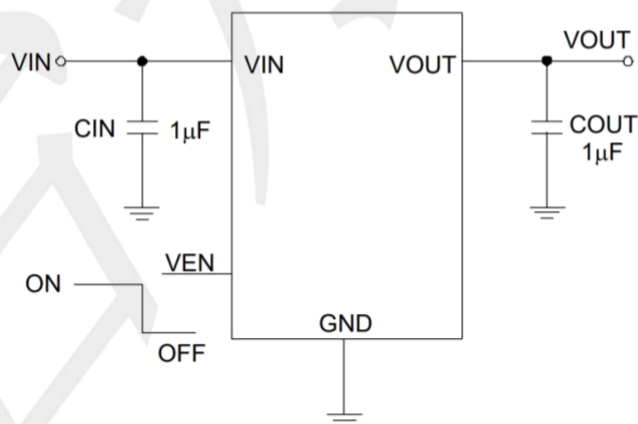

Electrical Characteristics

(VIN=15V, VEN=5V, TA=25°C, unless otherwise specified)

PARAMETER	SYMBOL	TEST Conditions	MIN	TYP	MAX	UNIT
Supply Voltage	VIN		1.7	--	6	V
Output current	IOUT		0	--	700	mA
DC Output Voltage Accuracy		IOUT = 0.1mA	-2	--	2	%
Dropout Voltage (VIN-VOUT)	IOUT = 100mA	VOUT = 1.5V	--	400	--	mV
		VOUT = 1.8V	--	300	--	
		VOUT = 2.8V	--	200	--	
		VOUT = 3.0V	--	180	--	
		VOUT = 3.3V	--	160	--	
		VOUT = 4.5V	--	130	--	
		VOUT = 5.0V	--	120	--	
Maximum output current	Ioutmax	VIN= VOUT+1V	--	700	--	mA
Ground Current (IOUT = 0mA)	Iq	VOUT = 3.3V	100	--	--	uA
Shutdown Ground Current	ISD	VEN = 0V,	--	0.01	0.5	
VOUT Shutdown Leakage Current	I _{LEAK}	VOUT = 0V	--	0.01	0.5	
Enable Threshold Voltage	V _{IH}	EN Rising	1.2	--	--	V
	V _{IL}	EN Falling	--	--	0.5	
EN Input Current	IEN	VEN = 5V	--	10	100	nA
Line Regulation	ΔLINE	IOUT = 1mA, 2 ≤ VIN ≤ 6V	--	0.3	--	%
Load Regulation	ΔLOAD	10mA ≤ IOUT ≤ 100mA	--	0.3	--	
Output Current Limit	I _{LIM}	VOUT=0.9× VOUT(NOM)	700	750		mA
Power Supply Rejection Ratio	PSRR	VOUT = 3.3V, IOUT = 30mA, VIN = 6V, f = 1kHz	--	65	--	dB
Thermal Shutdown Temperature	TSD	IOUT = 10mA	--	160	--	°C
Thermal Shutdown Hysteresis	ΔTSD		--	15	--	
Package Thermal Resistance θJA (Note 1)	SOT23-5	Thermal Resistance	--	210	--	°C/W
	SOT89-5	Junction-to-Ambient	--	100	--	
Total Power Dissipation Tc=25°C	SOT23-5	P _{DTOT}	--	0.6	--	W
	SOT89-5		--	1.25	--	

Note: 1. Test condition: For SOT23-5, the device is mounted on FR-4 substrate PC board, with minimum recommended pad layout. SOT89-5 devices are mounted on 1"x1" FR-4 substrate PC board, with minimum recommended pad layout

Typical Operating Characteristics (25 °C, unless otherwise noted)

Unless otherwise specified: $T_A = 25^\circ\text{C}$, $V_{IN} = V_O(\text{NOM}) + 1\text{V}$, $C_{OUT} = 1\ \mu\text{F}$, $C_{IN} = 1\ \mu\text{F}$ all voltage options, EN pin tied to V_{IN} .

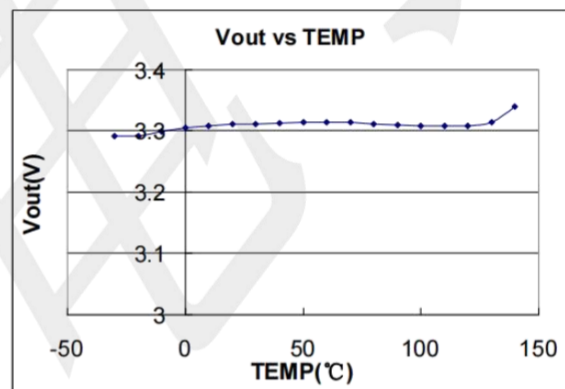
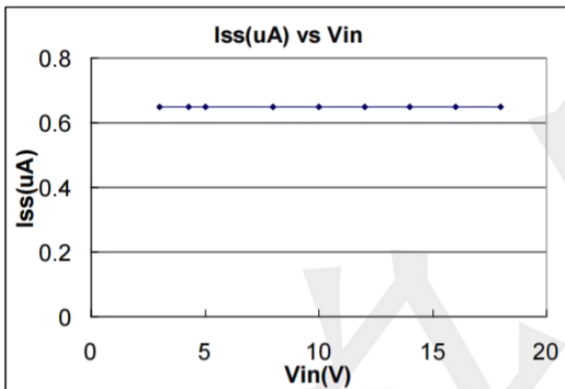
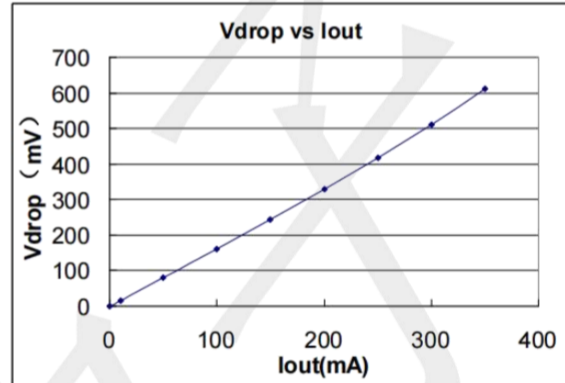
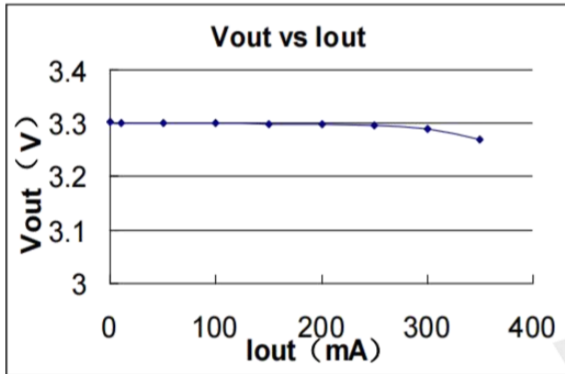

$I_{OUT} = 1\text{mA} \leftrightarrow 10\text{mA}$, $t_R = t_F = 5\mu\text{s}$, without C_{OUT}

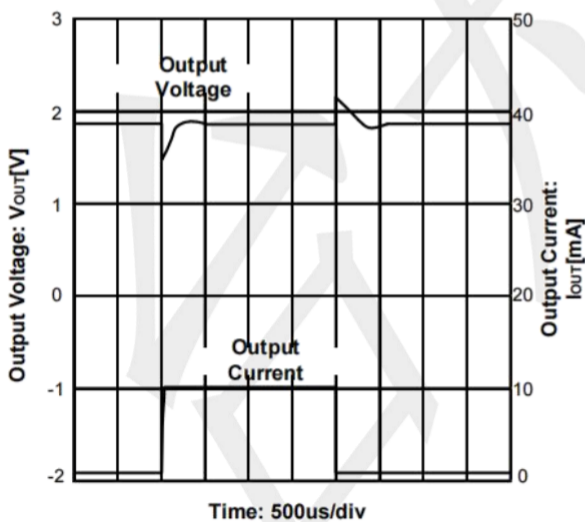

$I_{OUT} = 1\text{mA} \leftrightarrow 10\text{mA}$, $t_R = t_F = 5\mu\text{s}$

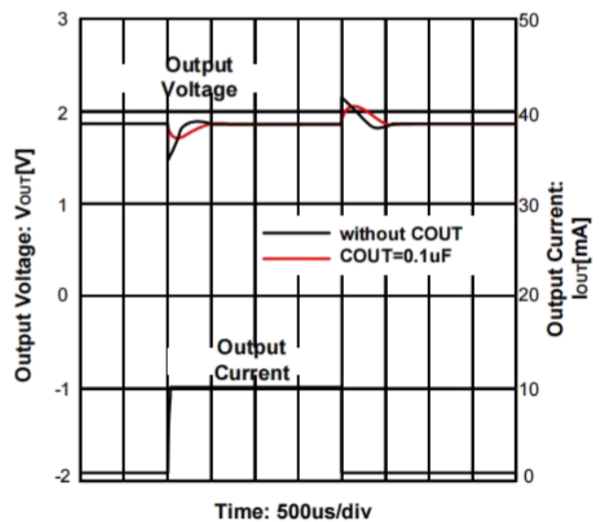

Package information

SOT23-5

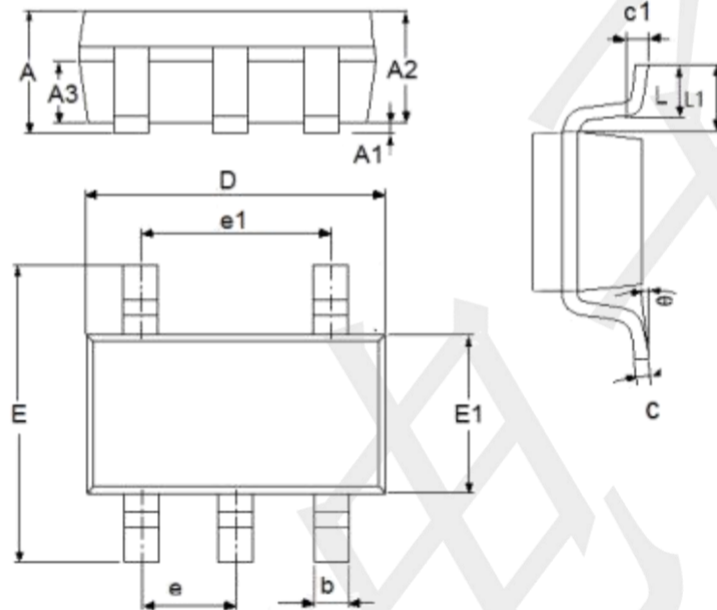

参数	尺寸 (mm)		尺寸 (Inch)	
	最小值	最大值	最小值	最大值
A	1.05	1.45	0.0413	0.0571
A1	0	0.15	0.0000	0.0059
A2	0.9	1.3	0.0354	0.0512
A3	0.6	0.7	0.0236	0.0276
b	0.25	0.5	0.0098	0.0197
c	0.1	0.23	0.0039	0.0091
D	2.82	3.05	0.1110	0.1201
e1	1.9(TYP)		0.0748(TYP)	
E	2.6	3.05	0.1024	0.1201
E1	1.5	1.75	0.0512	0.0689
e	0.95(TYP)		0.0374(TYP)	
L	0.25	0.6	0.0098	0.0236
L1	0.59(TYP)		0.0232(TYP)	
θ	0	8°	0.0000	8°
c1	0.2(TYP)		0.0079(TYP)	

Package information

SOT89-3

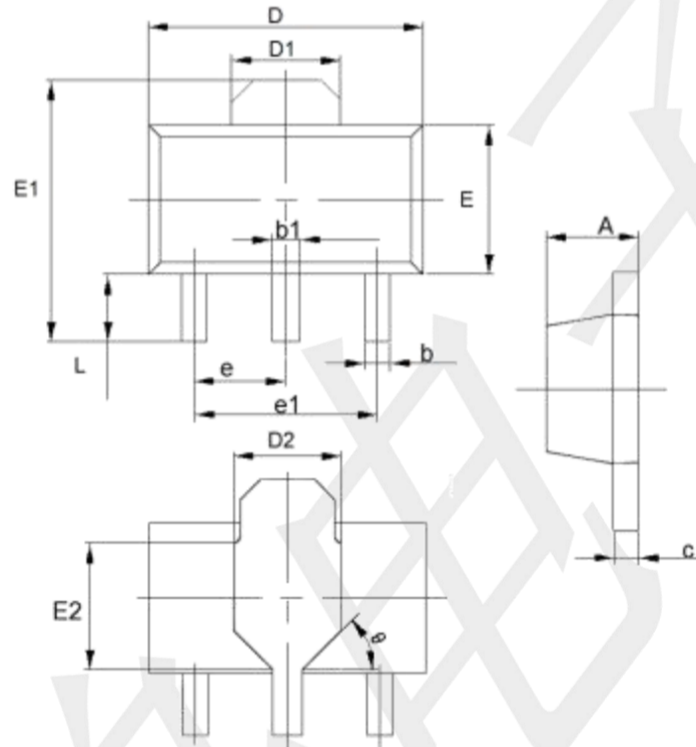

参数	尺寸 (mm)		尺寸 (Inch)	
	最小值	最大值	最小值	最大值
A	1.4	1.6	0.0551	0.0630
b	0.32	0.52	0.0126	0.0205
b1	0.4	0.58	0.0157	0.0228
c	0.35	0.45	0.0138	0.0177
D	4.4	4.6	0.1732	0.1811
D1	1.55(TYP)		0.061(TYP)	
D2	1.75(TYP)		0.0689(TYP)	
e1	3.0(TYP)		0.1181(TYP)	
E	2.3	2.6	0.0906	0.1023
E1	3.94	4.4	0.1551	0.1732
E2	1.9(TYP)		0.0748(TYP)	
e	1.5(TYP)		0.0591(TYP)	
L	0.8	1.2	0.0315	0.0472
θ	45°		45°	

X-ON Electronics

Largest Supplier of Electrical and Electronic Components

Click to view similar products for [LDO Voltage Regulators](#) category:

Click to view products by [TECH PUBLIC](#) manufacturer:

Other Similar products are found below :

[AP7363-SP-13](#) [NCV8664CST33T3G](#) [L79M05TL-E](#) [AP7362-HA-7](#) [PT7M8202B12TA5EX](#) [TCR3DF185,LM\(CT](#) [TLF4949EJ](#)
[NCP4687DH15T1G](#) [NCV8703MX30TCG](#) [LP2951CN](#) [NCV4269CPD50R2G](#) [AP7315-25W5-7](#) [NCV47411PAAJR2G](#) [AP2111H-1.2TRG1](#)
[ZLDO1117QK50TC](#) [AZ1117ID-ADJTRG1](#) [NCV4263-2CPD50R2G](#) [NCP114BMX075TCG](#) [MC33269T-3.5G](#) [TLE4471GXT](#) [AP7315-33SA-](#)
[7](#) [NCV4266-2CST33T3G](#) [NCP715SQ15T2G](#) [NCV8623MN-50R2G](#) [NCV563SQ18T1G](#) [NCV8664CDT33RKG](#) [NCV4299CD250R2G](#)
[NCV8702MX25TCG](#) [TLE7270-2E](#) [NCV562SQ25T1G](#) [AP2213D-3.3TRG1](#) [AP2202K-2.6TRE1](#) [NCV8170BMX300TCG](#)
[NCV8152MX300180TCG](#) [NCP700CMT45TBG](#) [AP7315-33W5-7](#) [NCP154MX180300TAG](#) [AP2210K-3.0TRE1](#) [AP2113AMTR-G1](#)
[NJW4104U2-33A-TE1](#) [MP2013AGG-5-P](#) [NCV8775CDT50RKG](#) [NJM2878F3-45-TE1](#) [S-19214B00A-V5T2U7](#) [S-19214B50A-V5T2U7](#) [S-](#)
[19213B50A-V5T2U7](#) [S-19214BC0A-E8T1U7*1](#) [S-19213B00A-V5T2U7](#) [S-19213B33A-V5T2U7](#) [S-19213BC0A-V5T2U7](#)