



DC-EC SERIES

General purpose DC LVDT

SPECIFICATIONS

- **High level $\pm 10\text{VDC}$ output**
- **Stroke ranges from ± 0.05 to $\pm 10\text{in}$**
- **0.25% linearity**
- **Reverse polarity protection**
- **Double magnetic shielding**
- **Stainless steel housing**
- **Imperial or metric threaded core**

Features

- Bi-polar DC operation
- Shock and vibration tolerant
- Captive core option (available on select models)
- AISI 400 Series stainless steel housing
- CE compliant
- Calibration certificate supplied with each unit

Applications

- Materials testing
- Z-axis position feedback for punch-presses
- Microscope X-Y stage position control
- Medical imaging
- Automotive suspension testing
- Flight simulators

The **DC-EC Series** DC operated LVDTs combine a computer-designed AC LVDT with custom integral signal conditioning to achieve premium performance. Operating on a nominal $\pm 15\text{VDC}$ supply, the DC-EC Series delivers an extremely linear, low noise, yet high frequency response $\pm 10\text{VDC}$ output.

Innovative design and manufacturing techniques further enhance the DC-EC performance and cost efficiency. The micro-miniature components employed were meticulously selected for maximum stability and thermal performance. Vacuum encapsulation of all elements affords excellent shock and vibration tolerance, while double magnetic shielding provides the utmost protection from stray fields.

Like in most of our LVDTs, the DC-EC windings are vacuum impregnated with a specially formulated, high temperature, flexible resin, and the coil assembly is potted inside its housing with a two-component epoxy. This provides excellent protection against hostile environments such as high humidity, vibration and shock.

Available in a variety of stroke ranges from ± 0.05 to ± 10 inches, the DC-EC Series can be configured with a number of standard options including metric threaded core, guided core and small diameter/low mass core.

Captive core option: The DC-EC features an optional captive core design (available for most models) that greatly simplifies installation. The core rod and bearing assembly includes a Bronze bearing on the front end for self-alignment, while a PTFE sleeve allows low-friction travel through the stainless steel boreliner (spool tube). The core rod and the bearing assembly are both field serviceable.

DC-EC SERIES

General purpose DC LVDT

Performance Specifications

ELECTRICAL SPECIFICATIONS									
Parameter	DC-EC 050	DC-EC 125	DC-EC 250	DC-EC 500	DC-EC 1000	DC-EC 2000	DC-EC 3000	DC-EC 5000	DC-EC 10000
Stroke range	±0.050 [±1.27]	±0.125 [±3.17]	±0.25 [±6.35]	±0.5 [±12.7]	±1 [±25.4]	±2 [±50.8]	±3 [±76.2]	±5 [±127]	±10 [±254]
Sensitivity, VDC/inch	200	80	40	20	10	5	3.3	2.0	1.0
Sensitivity, VDC/mm	7.9	3.15	1.6	0.79	0.39	0.20	0.13	0.079	0.039
Frequency response Hertz @-3dB	500	500	500	200	200	200	200	200	200
Input voltage	±15VDC								
Input current	±25mA								
Output at stroke ends	±10VDC (Positive and increasing when the core is displaced from null position towards the cable)								
Non-linearity	±0.25% of FR, maximum								
Output ripple	25mVRMS, maximum								
Stability	0.125% of FSO								
Output impedance	1 Ohm								

ENVIRONMENTAL SPECIFICATIONS & MATERIALS	
Operating temperature	+32°F to +160°F [0°C to 70°C]
Survival temperature	-65°F to +200°F [-55°C to 95°C]
Shock survival	250 g (11ms half-sine)
Vibration tolerance	10 g up to 2kHz
Housing material	AISI 400 Series stainless steel
Electrical connection	Cable with 4 conductors, 28AWG stranded copper, braided shield and polyurethane jacket, 39 inches [1 meter] long. Shield is connected to case.
IEC 60529 rating	IP61

Notes:

All values are nominal unless otherwise noted

Dimensions are in inch [mm] unless otherwise noted

FR: Full Range is the stroke range, end to end; FR=2xS for ±S stroke range

FSO (Full Scale Output): Largest absolute value of the outputs measured at the ends of the range

Wiring Information

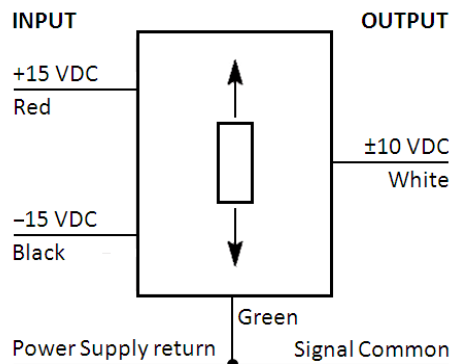

DC-EC SERIES

General purpose DC LVDT

Mechanical Specifications – Non-Captive Core (Standard)

Parameter	DC-EC 050	DC-EC 125	DC-EC 250	DC-EC 500	DC-EC 1000	DC-EC 2000	DC-EC 3000	DC-EC 5000	DC-EC 10000
Main body length "A"	2.10 [53.3]	2.93 [74.4]	3.80 [96.5]	5.49 [139.4]	7.75 [196.9]	11.12 [282.4]	16.32 [414.5]	20.15 [511.8]	35.38 [898.7]
Core length "B"	0.75 [19.1]	1.25 [31.8]	2.00 [50.8]	3.00 [76.2]	3.80 [96.5]	5.30 [134.6]	6.20 [157.5]	6.20 [157.5]	12.00 [304.8]
Core center at null "P"	0.50 [12.7]	0.93 [23.6]	1.35 [34.3]	2.20 [55.9]	3.18 [80.8]	4.88 [124.0]	7.55 [191.8]	9.53 [242.1]	16.58 [421.1]
Body weight oz [gram]	2.19 [62]	2.44 [69]	2.58 [73]	2.93 [83]	4.24 [120]	5.47 [155]	9.39 [266]	11.47 [325]	15.71 [445]
Core weight oz [gram]	0.07 [2]	0.11 [3]	0.18 [5]	0.28 [8]	0.35 [10]	0.46 [13]	0.49 [14]	0.60 [17]	0.85 [24]

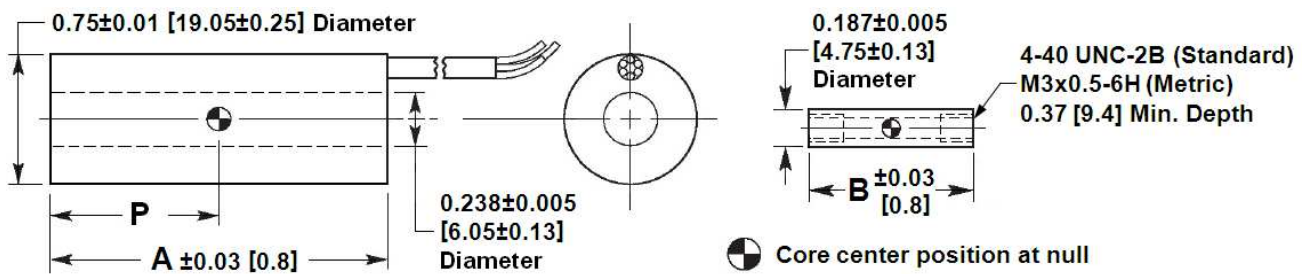

Dimensions are in inch [mm]

Mechanical Specifications – Captive Core Option

Parameter	DC-EC 050	DC-EC 125	DC-EC 250	DC-EC 500	DC-EC 1000	DC-EC 2000	DC-EC 3000
Main body length "A"	2.48 [63.0]	3.31 [84.1]	4.18 [106.7]	5.87 [149.1]	8.13 [206.5]	11.50 [292.1]	16.70 [424.2]
Core rod position at null "R"	3.78 [96.0]	4.36 [110.7]	4.85 [123.2]	6.04 [153.4]	7.90 [200.7]	10.52 [267.2]	15.27 [387.9]
Center of core position at null "P"	0.84 [21.3]	1.27 [32.3]	1.69 [42.9]	2.54 [64.5]	3.52 [89.4]	4.88 [124.0]	7.89 [200.4]
Weight oz [gram]	2.97 [84]	3.32 [94]	3.53 [100]	4.02 [114]	5.61 [159]	7.2 [204]	11.68 [331]

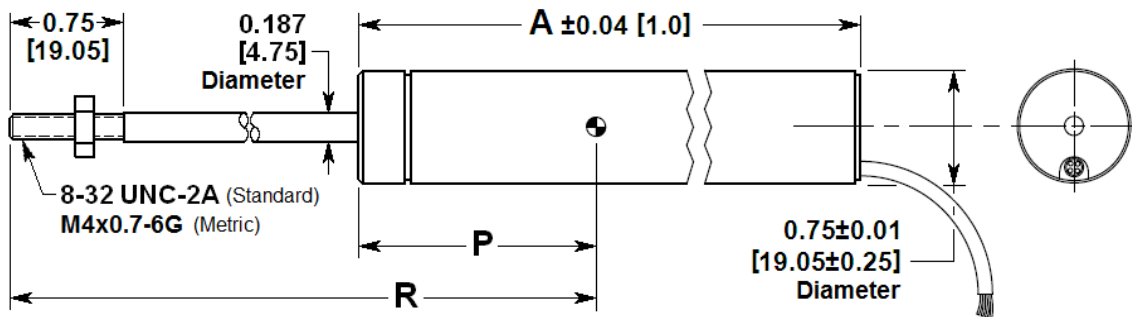

Dimensions are in inch [mm]

DC-EC SERIES

General purpose DC LVDT

Ordering Information

Description	Model	Part Number
±0.050 inch LVDT	DC-EC 050	02560981-000
±0.125 inch LVDT	DC-EC 125	02560982-000
±0.25 inch LVDT	DC-EC 250	02560983-000
±0.5 inch LVDT	DC-EC 500	02560984-000
±1 inch LVDT	DC-EC 1000	02560985-000

Description	Model	Part Number
±2 inch LVDT	DC-EC 2000	02560986-000
±3 inch LVDT	DC-EC 3000	02560987-000
±5 inch LVDT	DC-EC 5000	02560988-000
±10 inch LVDT	DC-EC 10000	02560989-000

OPTIONS		
Metric threaded core (M3 x 0.5-6H)	ALL DC-EC	XXXXXXXX-006
Guided core	ALL DC-EC	XXXXXXXX-010
Small-diameter/low-mass core (<i>consult factory for mass & dimensions</i>)	ALL DC-EC	XXXXXXXX-020
Captive core	DC-EC 050 thru 3000 only	XXXXXXXX-200

Note: Add multiple option dash numbers together to determine proper ordering suffix

Example: DC-EC 1000, ±1 inch, with metric threaded and guided core, P/N 02560985-016

ACCESSORIES		
Dual rail DC power supply (±15VDC)	Model PSD 40-15	02291339-000
Core connecting rod, 6 inches long, 4-40 threads		05282946-006
Core connecting rod, 12 inches long, 4-40 threads		05282946-012
Core connecting rod, 24 inches long, 4-40 threads		05282946-024
Core connecting rod, 36 inches long, 4-40 threads		05282946-036
Core connecting rod, 6 inches long, M3x0.5 metric threads		05282977-006
Core connecting rod, 12 inches long, M3x0.5 metric threads		05282977-012
Mounting block		04560950-000

NORTH AMERICA

Measurement Specialties, Inc.,
a TE Connectivity company
Tel: 800-522-6752
Email: customercare.frm1@te.com

EUROPE

Measurement Specialties (Europe), Ltd.,
a TE Connectivity Company
Tel: 800-440-5100
Email: customercare.bevx@te.com

ASIA

Measurement Specialties (China) Ltd.,
a TE Connectivity company
Tel: 0400-820-6015
Email: customercare.shzn@te.com

te.com

TE Connectivity, TE, TE Connectivity (logo) and Every Connection Counts are trademarks. All other logos, products and/or company names referred to herein might be trademarks of their respective owners

The information given herein, including drawings, illustrations and schematics which are intended for illustration purposes only, is believed to be reliable. However, TE Connectivity makes no warranties as to its accuracy or completeness and disclaims any liability in connection with its use. TE Connectivity's obligations shall only be as set forth in TE Connectivity's Standard Terms and Conditions of Sale for this product and in no case will TE Connectivity be liable for any incidental, indirect or consequential damages arising out of the sale, resale, use or misuse of the product. Users of TE Connectivity products should make their own evaluation to determine the suitability of each such product for the specific application.

© 2019 TE Connectivity Corporation. All Rights Reserved.

Version # 11/2020



X-ON Electronics

Largest Supplier of Electrical and Electronic Components

Click to view similar products for [Linear Displacement Sensors](#) category:

Click to view products by [TE Connectivity](#) manufacturer:

Other Similar products are found below :

[9810405](#) [9810421](#) [Z4D-F04A](#) [05282945-012](#) [67010001-000](#) [ZG-RPD11](#) [9810907](#) [9810908](#) [04-0760-0006](#) [LCPL Wiper-01](#) [04-0882-0237](#)
[02560412-006](#) [04-0847-0023](#) [02560618-000](#) [RP12250L223BWB](#) [RP12300L223BWB](#) [02560390-000](#) [02350512-000](#) [02560394-000](#)
[HMC1512-TR](#) [E3FC-RN21](#) [E3FC-DP23](#) [E3FC-DP13 2M](#) [LCPL400-10K](#) [060-3613-02](#) [F38000100](#) [F38000105](#) [F38000205](#) [F38000206](#)
[SPS-L035-LATS](#) [SPS-L075-HALS](#) [SPS-L225-HALS](#) [SPS-L225-HDLS](#) [02560407-000](#) [02560409-000](#) [02560405-000](#) [02560408-000](#)
[02560406-000](#) [02560542-000](#) [02560541-000](#) [02560545-000](#) [02560992-000](#) [05282946-006](#) [02560395-000](#) [02560389-000](#) [02560391-000](#)
[05282947-012](#) [02560398-000](#) [04560950-000](#) [62101011-000](#)