

REVISIONS				
P	LTN	DESCRIPTION	DATE	APVD
V		REDRAWN/REVISED PER ECO 17-001755	19MAY2017	RS JO
W		REVISED PER ECO-20-000174	19FEB2020	SM JO

- 1 0.76µm GOLD IN LOCALIZED PLATE AREA, 3.81µm TIN-LEAD ON SOLDER TAILS ALL OVER 1.27µm NICKEL.
- 2 USE 1.18±.025 DRILLED HOLE (#56 DRILL) WITH .025 MIN COPPER.
- 3 CIRCUIT IDENTIFICATION FEATURE OMITTED ON 10 POSITION HEADER ASSEMBLIES.
- 4 DIMENSION APPLIES AT BASE OF SHROUD.
- 5 NOTE DELETED.
- 6 NOTE DELETED.
- 7 PADS ON THE OPPOSITE SIDE OF THE BOARD TO BE Ø1.65 MINIMUM.
- 8 REFER TO NO. OF POSN. IN CHART FOR NUMBER OF SURFACES THAT ARE TO BE COPLALAR.
- 9 0.76µm GOLD IN LOCALIZED PLATE AREA, 3.81µm TIN ON SOLDER TAILS, ALL OVER 1.27µm NICKEL.
- 10 NO CIRCUIT IDENTIFICATION FEATURE ON 10,12,20,24 AND 30 POSITION PARTS.
- 11 FINISH: 0.0254µm MIN. GOLD GOLD PLATED AREA, 3.81-6.35µm MATTE TIN LEAD ON TIN PLATE AREA, UNDER PLATING SHOULD BE 1.27-2.54µm NICKEL ON ENTIRE CONTACT, GOLD AND TIN PLATING MAY NOT OVERLAP.
- 12 FINISH: 0.0254µm MIN GOLD ON GOLD PLATED AREA, 3.81-6.35µm MATTE TIN ON TIN PLATE AREA, UNDERPLATING TO BE 1.27-2.54µm NICKEL ON ENTIRE CONTACT, GOLD AND TIN PLATING MAY NOT OVERLAP.
- 13 NOTE DELETED.
- 14 NOTE DELETED.
- 15 MATERIAL : HOUSING : LCP  
COLOR : BLACK  
CONTACT : COPPER ALLOY.

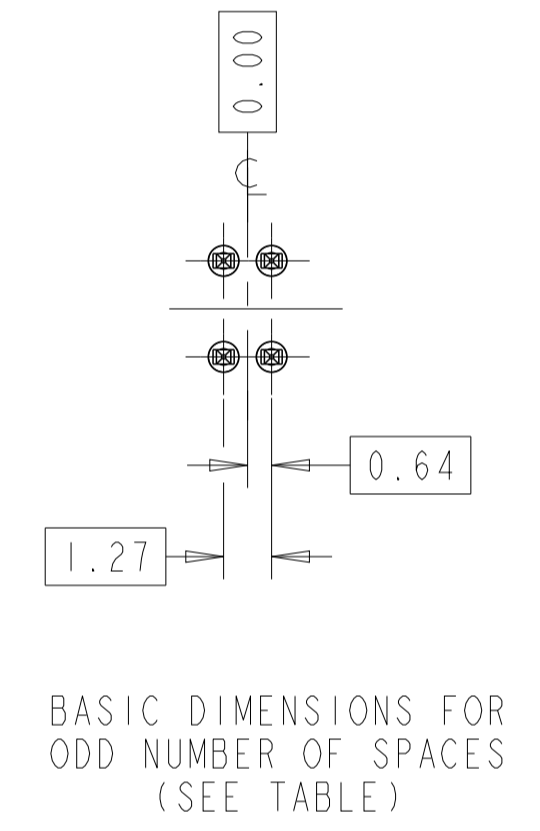

DETAIL S

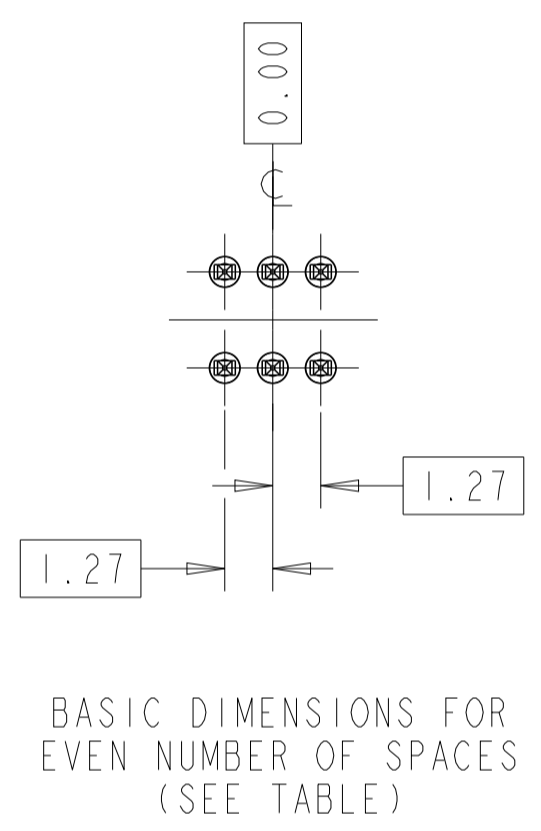
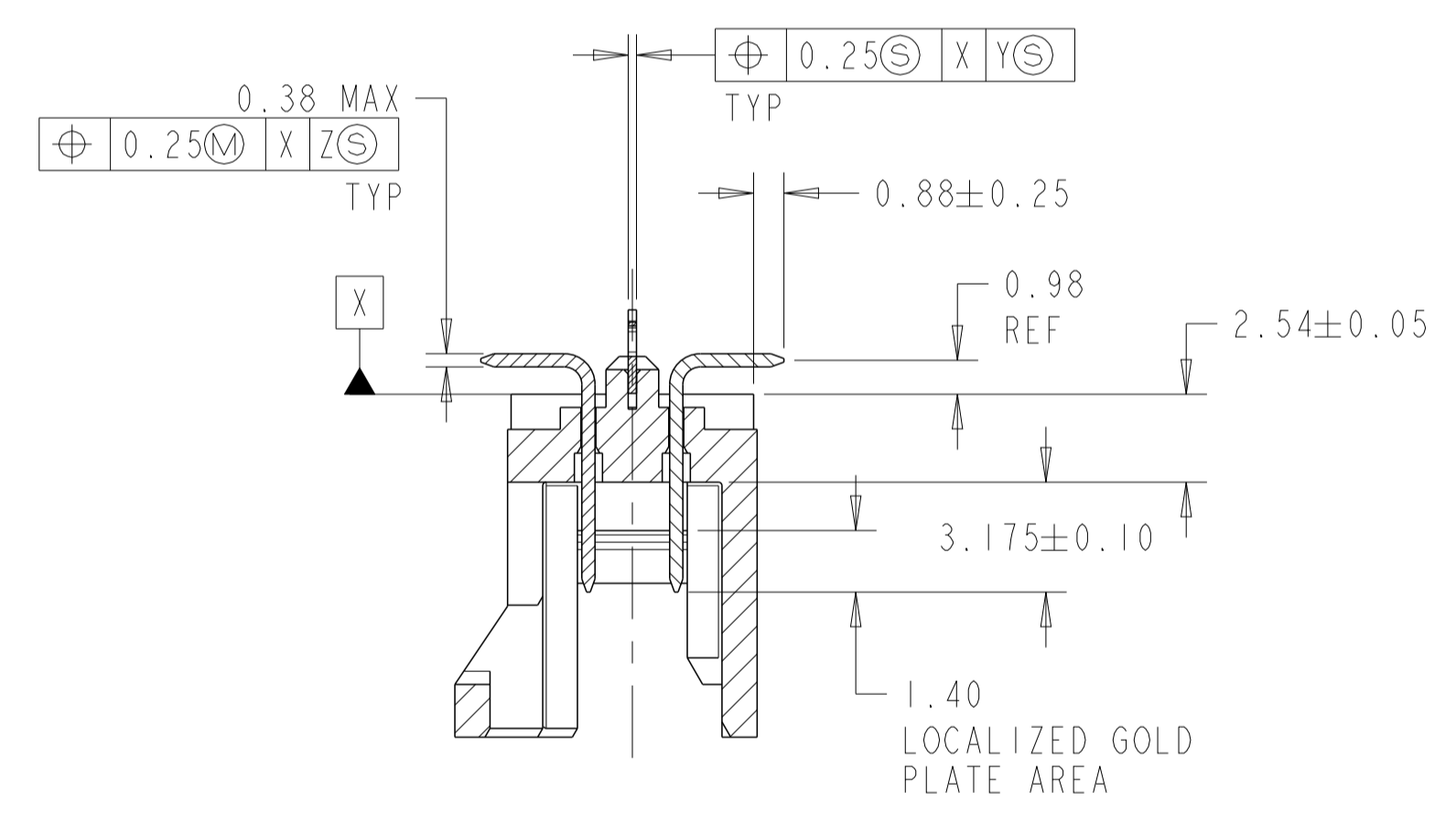
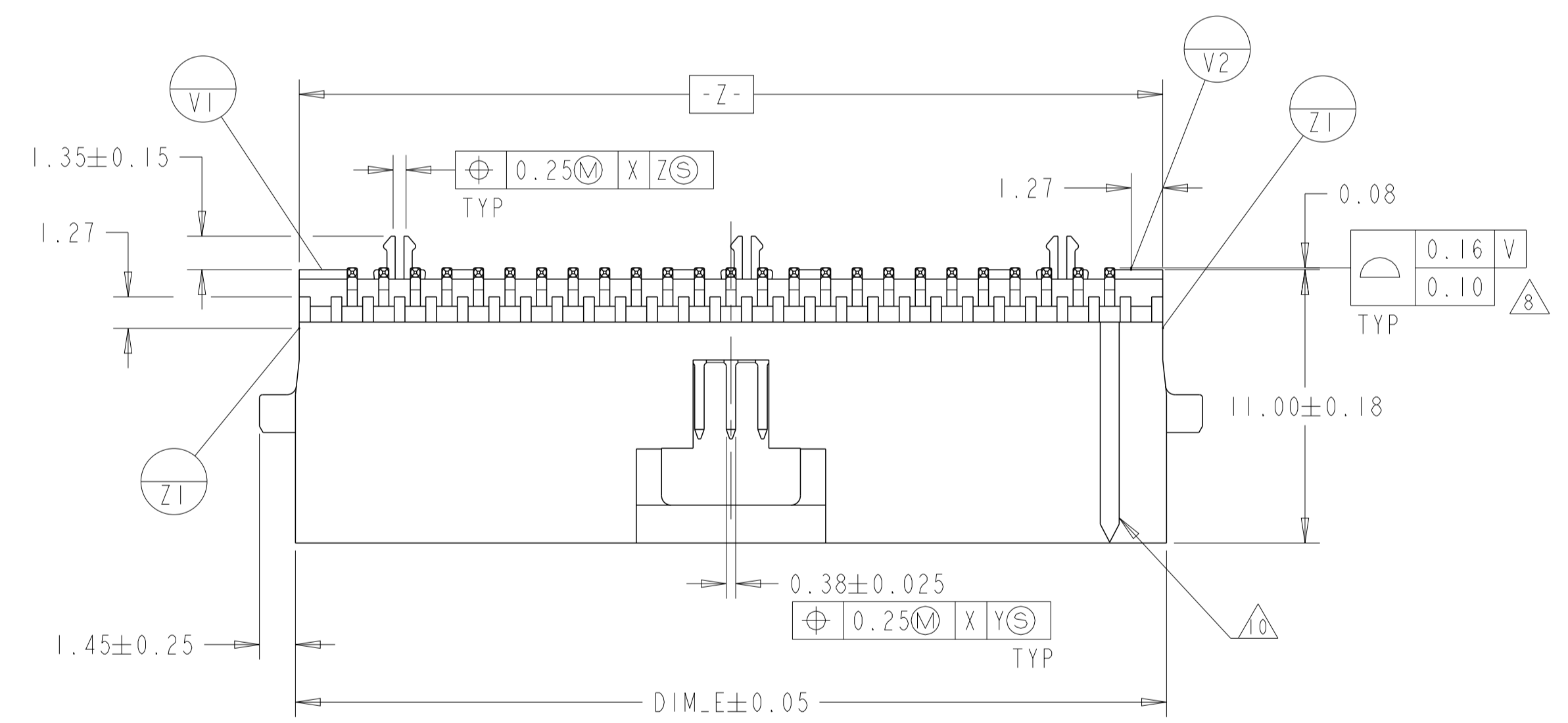
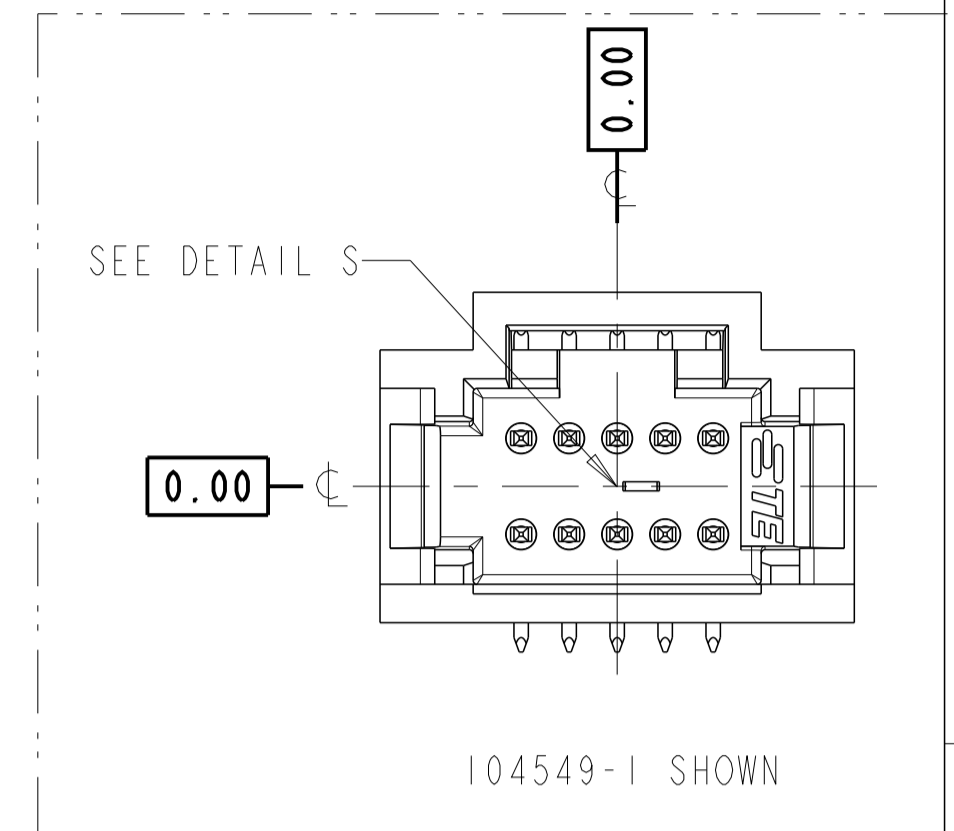
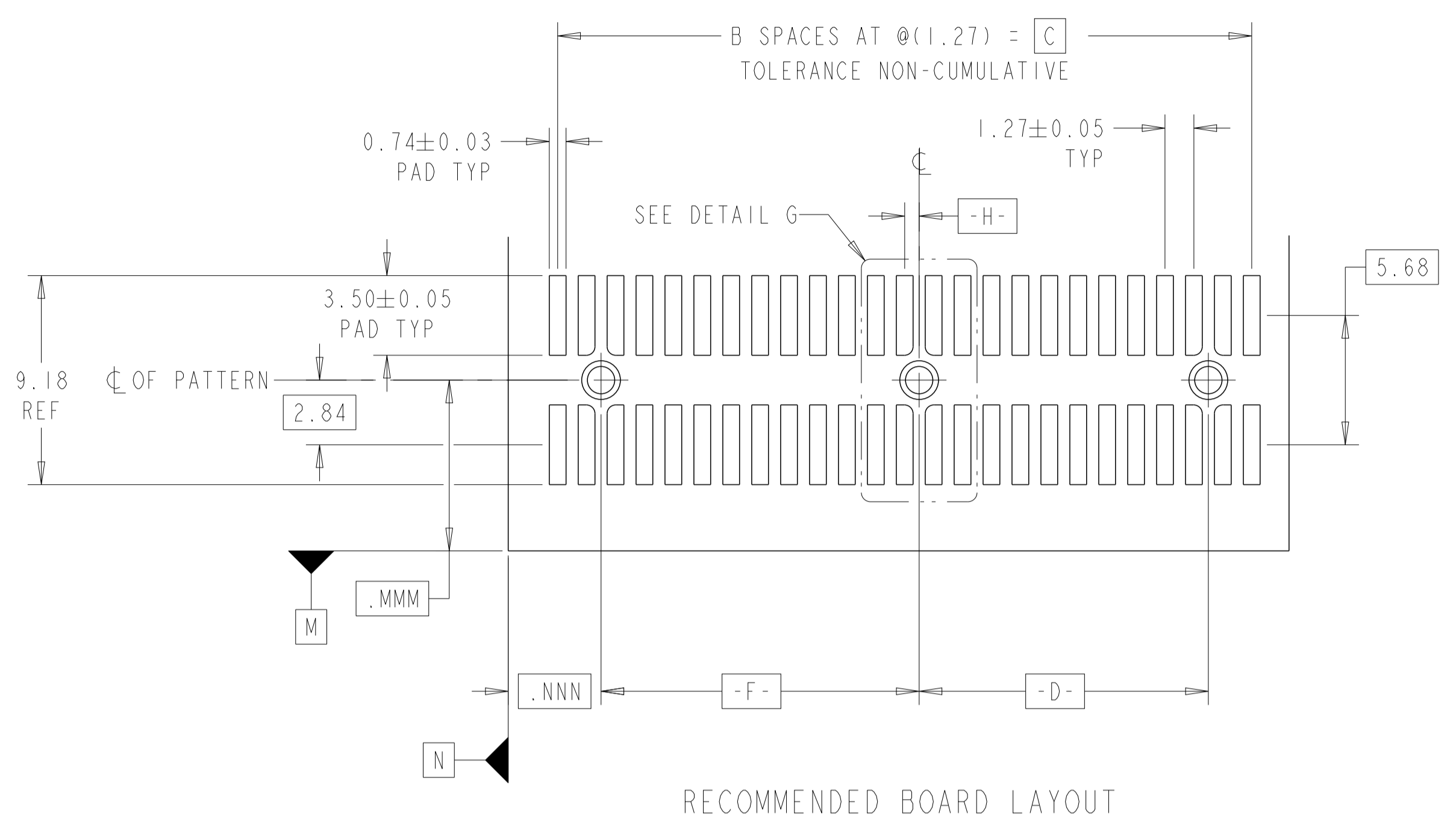
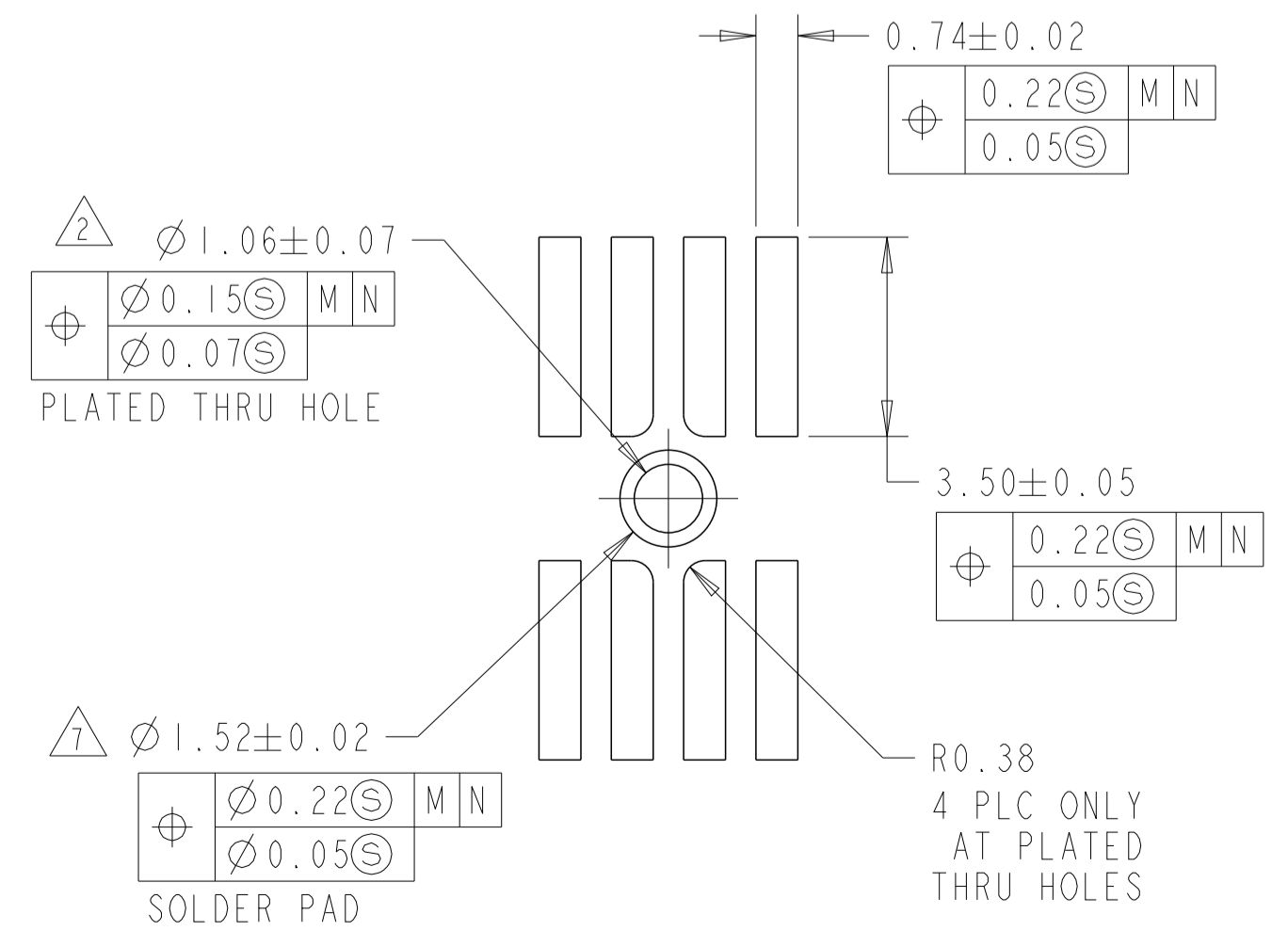
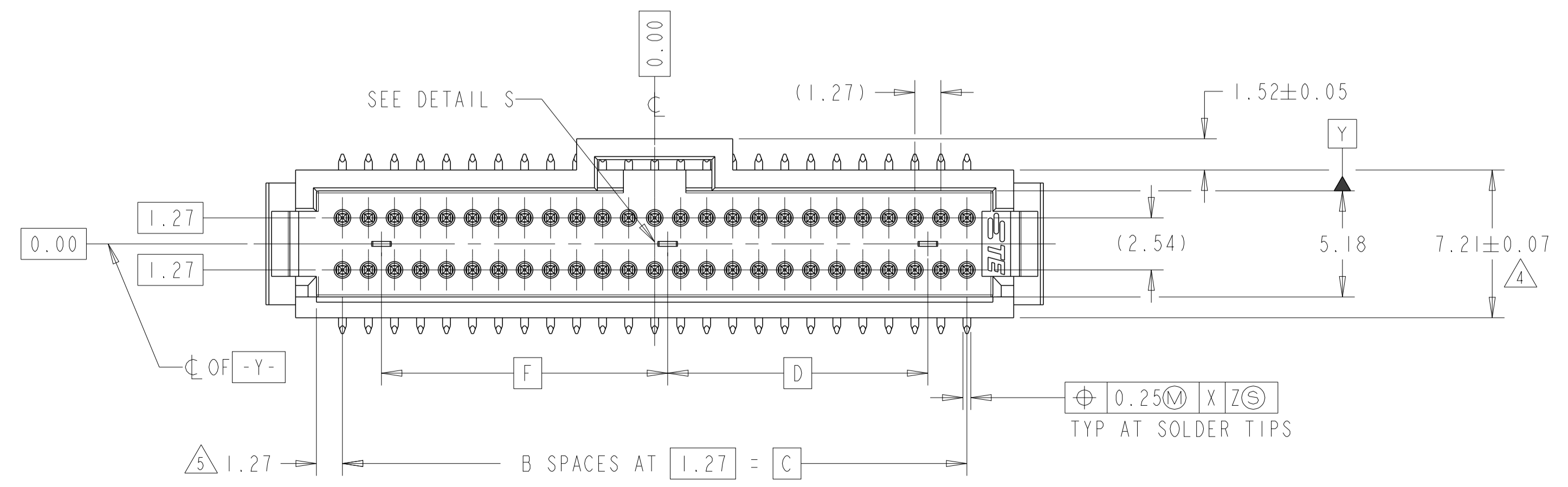

DETAIL G SCALE 8:1

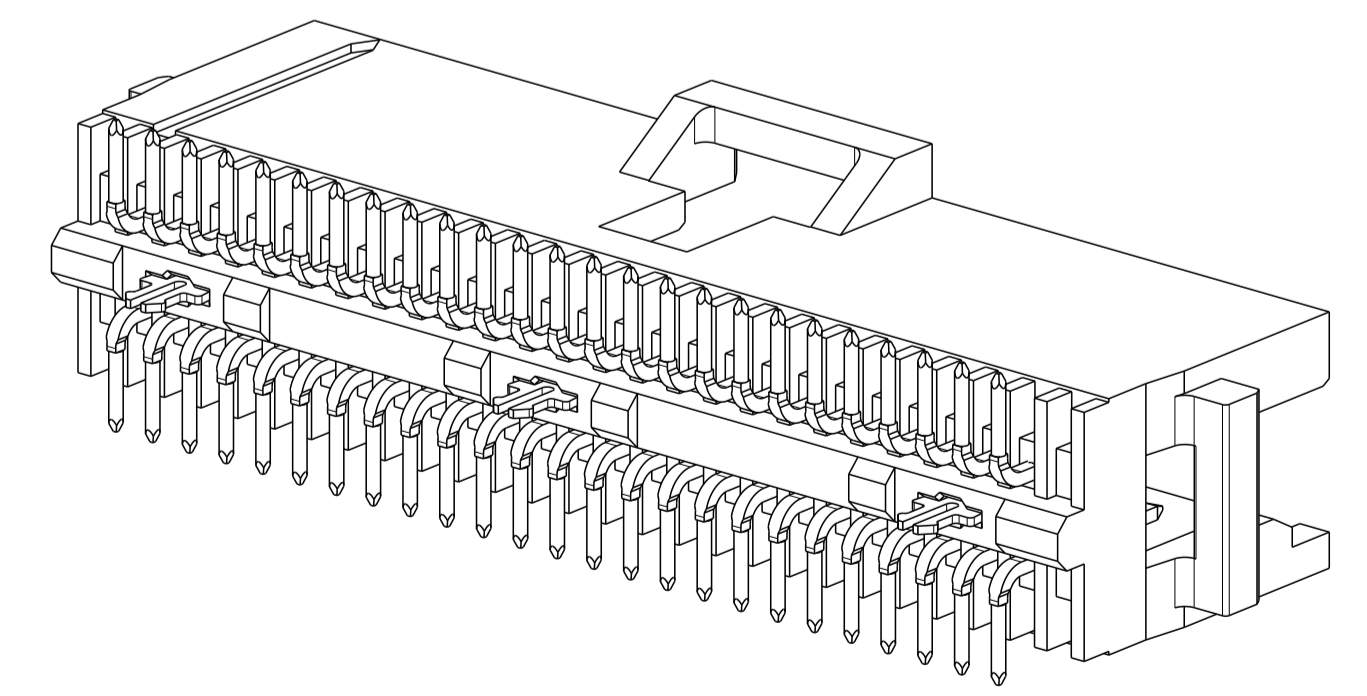

THIS DRAWING IS A CONTROLLED DOCUMENT.		OWN: RAVI.S 19MAY2017	TE Connectivity
DIMENSIONS: mm		CHK: J. OLSON 19MAY2017	
TOLERANCES UNLESS OTHERWISE SPECIFIED:		APVD: J. OLSON 19MAY2017	NAME: HEADER ASSY, VERTICAL, SHROUDED DUAL ROW, W/LATCHES AND HOLD DOWNS
0 PLC ±0.3	1 PLC ±0.3	PRODUCT SPEC	SIZE: A1
2 PLC ±0.13	3 PLC ±0.13	APPLICATION SPEC	CAGE CODE: C=104549
4 PLC ±0.13	ANGLES ±0.13	WEIGHT	RESTRICTED TO
MATERIAL: SEE TABLE		CUSTOMER DRAWING	SCALE: 5:1 SHEET 1 OF 2 REV W

THIS DRAWING IS UNPUBLISHED. RELEASED FOR PUBLICATION. ALL RIGHTS RESERVED.

REVISIONS				
P	LTN	DESCRIPTION	DATE	APPD
-	-	SEE SHEET 1	-	-

FINISH	DIM_G	DIM_H	DIM_F	DIM_D	DIM_C	NO OF SPACES	DIM_E	NO OF POSN	PART NUMBER	FINISH	DIM_G	DIM_H	DIM_F	DIM_D	DIM_C	NO OF SPACES	DIM_E	NO OF POSN	PART NUMBER
12	-	-	-	0.00	6.35	5	10.92	12	8-104549-1	11	-	-	-	0.00	6.35	5	10.92	12	3-104549-1
	-	0.00	29.21	29.21	62.23	49	66.80	100	8-104549-0		-	0.00	29.21	29.21	62.23	49	66.80	100	3-104549-0
	-	0.00	22.86	22.86	49.53	39	54.10	80	7-104549-9		-	0.00	22.86	22.86	49.53	39	54.10	80	2-104549-9
	-	0.00	16.51	16.51	36.83	29	41.40	60	7-104549-8		-	0.00	16.51	16.51	36.83	29	41.40	60	2-104549-8
	-	0.64	13.34	13.34	30.48	24	35.05	50	7-104549-7		-	0.64	13.34	13.34	30.48	24	35.05	50	2-104549-7
	-	-	10.16	10.16	24.13	19	28.70	40	7-104549-6		-	-	10.16	10.16	24.13	19	28.70	40	2-104549-6
	-	-	6.99	6.99	17.78	14	22.35	30	7-104549-5		-	-	6.99	6.99	17.78	14	22.35	30	2-104549-5
	-	-	5.72	5.72	15.24	12	19.81	26	7-104549-4		-	-	5.72	5.72	15.24	12	19.81	26	2-104549-4
	-	-	5.08	5.08	13.97	11	18.54	24	7-104549-3		-	-	5.08	5.08	13.97	11	18.54	24	2-104549-3
	-	-	3.81	3.81	11.43	9	16.00	20	7-104549-2		-	-	3.81	3.81	11.43	9	16.00	20	2-104549-2
12.55	-	-	0.64	5.08	4	-	10	7-104549-1	12.55	-	-	0.64	5.08	4	-	10	2-104549-1		
9	-	-	-	0.00	6.35	5	10.92	12	6-104549-1	1	-	-	-	0.00	6.35	5	10.92	12	1-104549-1
	-	0.00	29.21	29.21	62.23	49	66.80	100	6-104549-0		-	0.00	29.21	29.21	62.23	49	66.80	100	1-104549-0
	-	0.00	22.86	22.86	49.53	39	54.10	80	5-104549-9		-	0.00	22.86	22.86	49.53	39	54.10	80	104549-9
	-	0.00	16.51	16.51	36.83	29	41.40	60	5-104549-8		-	0.00	16.51	16.51	36.83	29	41.40	60	104549-8
	-	0.64	13.34	13.34	30.48	24	35.05	50	5-104549-7		-	0.64	13.34	13.34	30.48	24	35.05	50	104549-7
	-	-	10.16	10.16	24.13	19	28.70	40	5-104549-6		-	-	10.16	10.16	24.13	19	28.70	40	104549-6
	-	-	6.99	6.99	17.78	14	22.35	30	5-104549-5		-	-	6.99	6.99	17.78	14	22.35	30	104549-5
	-	-	5.72	5.72	15.24	12	19.81	26	5-104549-4		-	-	5.72	5.72	15.24	12	19.81	26	104549-4
	-	-	5.08	5.08	13.97	11	18.54	24	5-104549-3		-	-	5.08	5.08	13.97	11	18.54	24	104549-3
	-	-	3.81	3.81	11.43	9	16.00	20	5-104549-2		-	-	3.81	3.81	11.43	9	16.00	20	104549-2
12.55	-	-	0.64	5.08	4	-	10	5-104549-1	12.55	-	-	0.64	5.08	4	-	10	104549-1		

THIS DRAWING IS A CONTROLLED DOCUMENT.

DIMENSIONS:	TOLERANCES UNLESS OTHERWISE SPECIFIED:	OWN	19MAY2017
mm	0 PLC ±0.3	CHK	19MAY2017
	1 PLC ±0.3	APPD	19MAY2017
	2 PLC ±0.13	NAME	
	3 PLC ±0.13	RAVI, S	
	4 PLC ±0.13	J. OLSON	
	ANGLES ±0.1°	PRODUCT SPEC	
	FINISH SEE TABLE	APPLICATION SPEC	
MATERIAL		SIZE	CAGE CODE
		A1	-
		DRAWING NO	RESTRICTED TO
		C=104549	W
		WEIGHT	SCALE
			4:1
		CUSTOMER DRAWING	SHEET 2 OF 2

TE Connectivity  
 HEADER ASSY, VERTICAL, SHROUDED DUAL ROW, W/LATCHES AND HOLD DOWNS

## X-ON Electronics

Largest Supplier of Electrical and Electronic Components

*Click to view similar products for [Board to Board & Mezzanine Connectors](#) category:*

*Click to view products by [TE Connectivity](#) manufacturer:*

Other Similar products are found below :

[589158040000018](#) [MDF7C-18P-2.54DSA\(55\)](#) [FCN-230C068-11](#) [FCN-268F012-G/BD](#) [FCN-268F036-G/BD](#) [FCN-268M012-G/0D](#) [FCN-268M024-G/1D](#) [FCN-723J004/1](#) [MIS-048-01-F-D-DP-K](#) [832-10-034-10-001000](#) [FX4C-80S-1.27DSA](#) [FCN-214Q030-G/0](#) [FCN-234P048-G/0](#) [FCN-235D050-G/C](#) [210-93-314-41-105000](#) [2-22603-0](#) [MDF7-40DP-2.54DSA\(55\)](#) [AXG720047](#) [5031084030](#) [MIT-114-03-F-D-K](#) [55323-1519](#) [DF33-2P-3.3DSA\(24\)](#) [YFT-20-05-H-03-SB-K](#) [503308-3040](#) [026-6203-PDB](#) [027-6203-PDB](#) [069159702701000](#) [10123981-102LF](#) [101A10019X](#) [55650-0588-C](#) [68682-310LF](#) [68684-306](#) [75140-7012](#) [87471-650](#) [194261-1](#) [FCN-268F024-G0D](#) [10124054-515LF](#) [68685-603](#) [8-1616154-3](#) [MIS-019-01-F-D](#) [FCN-268M024-G/3D](#) [20021832-06016C1LF](#) [KX15-20KLDL-E1000E](#) [MDF7-16DP-2.54DSA\(55\)](#) [AXE810124](#) [FCN-214J100-G/0](#) [FCN-230C068-E/S](#) [AXE812124](#) [AXE816124](#) [AXE720127](#)