

## Production Torque Wrenches

ORIGINAL INSTRUCTIONS

### PROPER USE GUIDELINES

Cumulative Trauma Disorders can result from the prolonged use of manually powered hand tools. Hand tools are intended for occasional use and low volume applications. A wide selection of powered application equipment for extended-use, production operations is available.

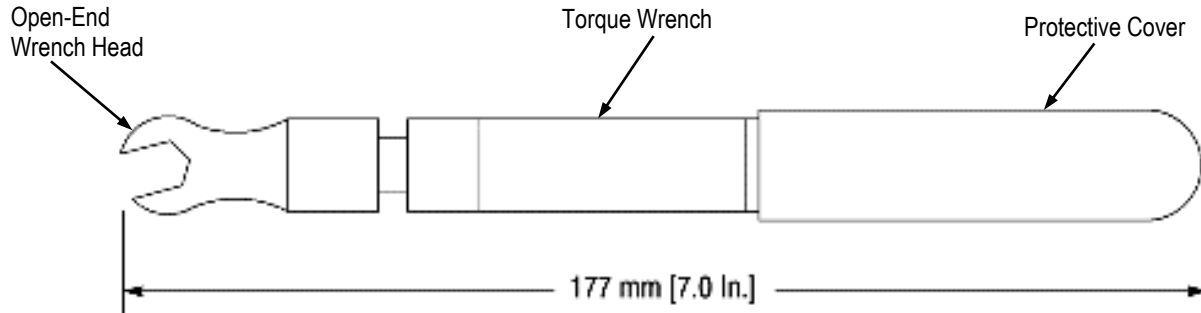

TE CONNECTIVITY PART NUMBER	PREVIOUS PART NUMBER	WRENCH DESCRIPTION	WRENCH SIZE		PRESET TORQUE
			mm	[inches]	
1055276-1	2098-0351-54	Production Torque Wrench	6.4	1/4	14 in.-lbs ±2 lb
1055419-1	2098-5065-54	For SMA (OSM) Type Connectors	7.9	5/16	8 in.-lbs +1.5/- .5 lb
1055480-1	2098-5304-54	For OSSM Type Connectors	6.4	1/4	5 in.-lbs ±.5 lb
1055512-1	2098-5619-54	For SMA (OSM) Hermetic Type Connectors	7.1	9/32	30 in.-lbs ±2 lb
1055546-1	2098-5830-54	Production Torque Wrench Kit	6.4 and 8.0	1/4 and 5/16	8 in.-lbs +1.5/- .5 lb
1055790-1	2598-5026-54	For SC/N Type Connectors (Hex Nut Design)	20.6	13/16	14 in.-lbs ±2 lb
1055791-1	2598-5027-54	For TNC Type Connectors (Hex Nut Design)	15.9	5/8	14 in.-lbs ±2 lb
1055826-1	2598-5160-54	Production Torque Wrench	4.0	5/32	8 in.-lbs +1.5/- .5 lb
1055868-1	2598-5298-54	For TNC Type Connectors (Hex Nut Design)	14.3	9/16	14 in.-lbs±2 lb
1061789-1	7098-5031-54	For 7mm Type Connectors	19.1	3/4	14 in.-lbs ±2 lb
1490262-1	2598-5383-50	Production Torque Wrench	7.9	5/16	15 in.-lbs ±2 lb

Figure 1

## 1. INTRODUCTION

These production torque wrenches are used to properly install or disassemble the connectors listed in Figure 1.

Figure 1 also contains the TE part numbers for the wrenches, the previous part numbers for the wrenches, wrench size, and the preset torque for each wrench.

**i NOTE**  
 Dimensions on this sheet are in metric units [with U.S. customary units in brackets], unless otherwise noted.

Reason for revision is provided in Section 5, REVISION SUMMARY.

## 2. DESCRIPTION

Each production torque wrench contains a protective cover, a torque wrench, and an interchangeable head.

Refer to Figure 2 for the appropriate replacement wrench head part numbers.

The wrenches are designed to be used in the *clockwise* or *counterclockwise* direction.

### 3. OPERATION OF THE WRENCHES



**NOTE**

*If a wrench has not been used recently, move the wrench head back and forth several times, listening for audible "clicks." Clicking the wrench head back and forth spreads lubricant throughout the internal mechanism to improve wrench performance.*

TE CONNECTIVITY PART NUMBER	WRENCH SIZE	
	mm	[inches]
1406504-1	6.4	[1/4]
1406504-2	8.0	[5/16]
1406504-3	9.6	[3/8]
1406504-4	12.8	[1/2]
1406504-5	19.6	[3/4]
1406504-6	11.2	[7/16]
1406504-7	7.1	[9/32]
1406504-8	10.4	[13/32]
1406504-9	17.6	[11/16]
1-1406504-0	14.6	[9/16]
1-1406504-1	8.8	[11/32]
1-1406504-2	16.0	[5/8]
1-1406504-3	20.8	[13/16]
1-1406504-4	4.0	[5/32]
1-1406504-5	6.1	[15/64]

Figure 2

Using the appropriate sized head (Figure 1), turn the wrench clockwise (or counterclockwise) until there is an audible "click." This "click" indicates that the proper torque has been achieved.



**CAUTION**

*Do NOT over-tighten the connector with the torque wrench. Over-tightening the wrench could result in inaccurate torque settings.*



**CAUTION**

*Do not use or re-terminate damaged connectors.*

### 4. REPLACEMENT

Remove the wrench head by pulling it off the production torque wrench. Then replace the head with the appropriate head listed in Figure 2.

Order replacement parts through your TE Representative, or call 1-800-526-5142, or send a facsimile of your purchase order to 717-986-7605, or write to:

CUSTOMER SERVICE (038-035)  
 TYCO ELECTRONICS CORPORATION  
 PO BOX 3608  
 HARRISBURG PA 17105-3608

### 5. REVISION SUMMARY

- Updated document to corporate requirements
- Added tolerances to table in Figure 1

## X-ON Electronics

Largest Supplier of Electrical and Electronic Components

*Click to view similar products for [Spanners](#) category:*

*Click to view products by [TE Connectivity](#) manufacturer:*

Other Similar products are found below :

[74005](#) [74008](#) [1406504-3](#) [1406504-4](#) [1406504-5](#) [1406504-7](#) [1725859-2](#) [9965](#) [999-16625-001](#) [G70515-18](#) [1055265-1](#) [1055267-1](#) [1-1406504-0](#) [1055787-1](#) [DCH.91.251.PA](#) [TG70-18](#) [TG70](#) [G62748-11](#) [DPH.99.005.2K](#) [DCP.91.045.TN](#) [1055512-1](#) [1055276-1](#) [R282303020](#) [TA-0456](#) [DCA.91.149.0TN](#) [TA-0436](#) [TA-0398](#) [TOL-222901](#) [74\\_Z-0-0-193](#) [294GB-5069-17-N](#) [74\\_Z-0-0-2](#) [523200-4](#) [294GB-5070-25-A](#) [74\\_Z-0-0-79](#) [294GB-5070-17-A](#) [74\\_Z-0-0-321](#) [TOL-171801](#) [PR23350](#) [1490262-2](#) [9968](#) [AC24VS](#) [80117](#) [DCN.91.149.0TK](#) [BT-A-6010CAGE](#) [R282340000](#) [BT-BS-609WT](#) [BT-A-6000B](#) [R282303000](#) [BT-BS-610R](#) [BT-BS-610RT](#)