

DO NOT SCALE  
DIMENSIONS IN mm

METRIC

THIRD ANGLE  
PROJECTION

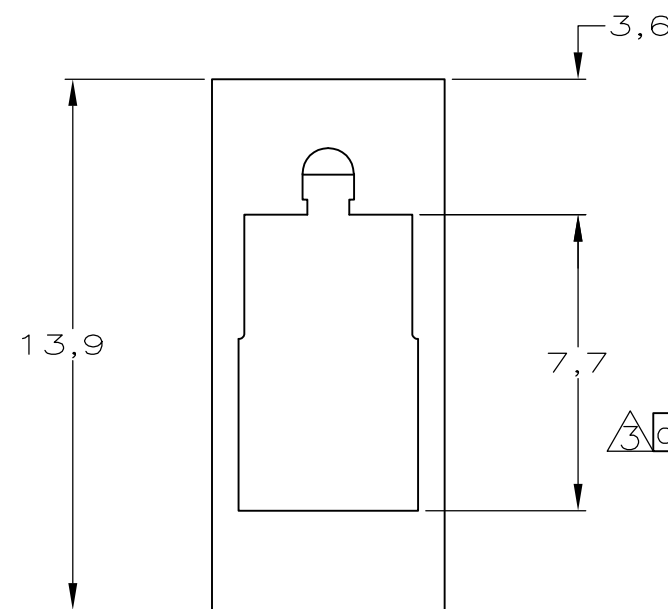
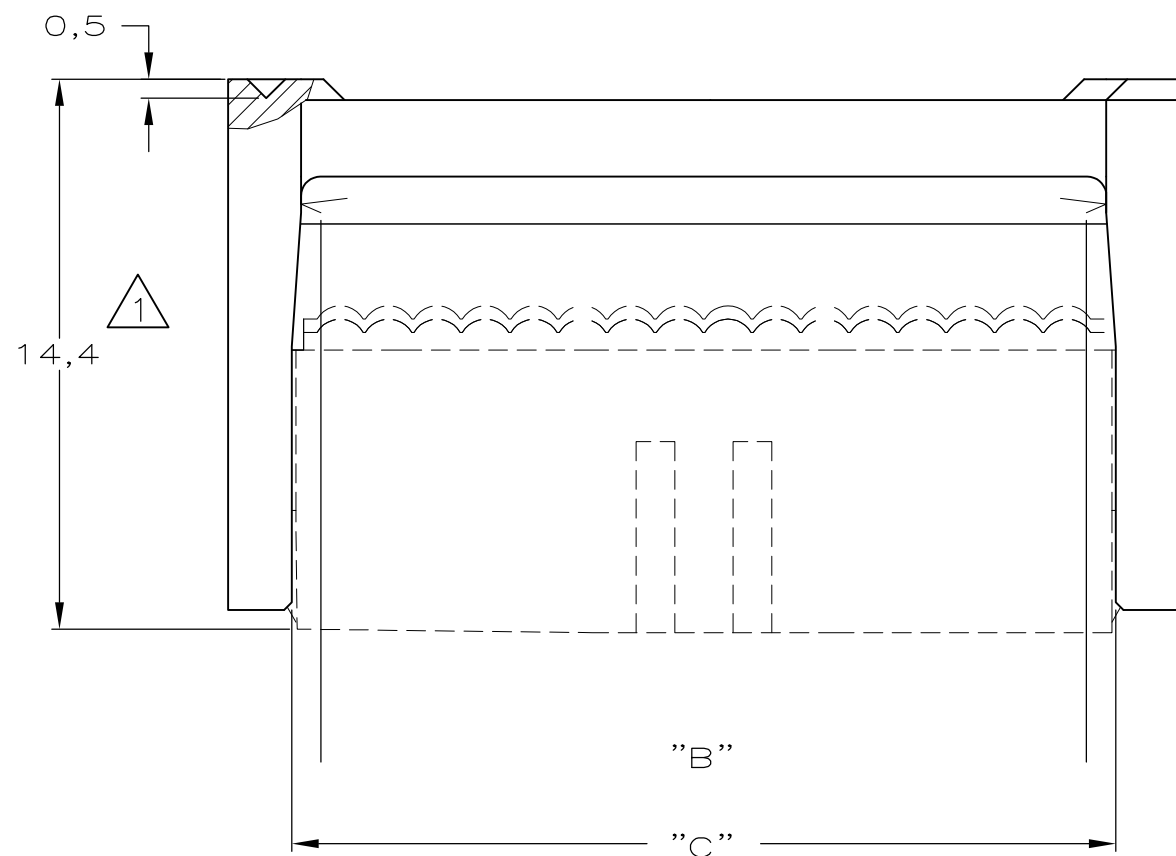
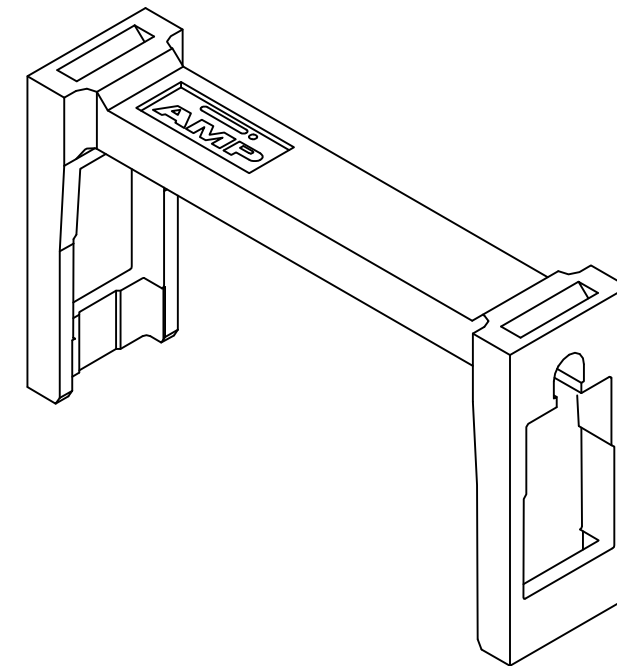
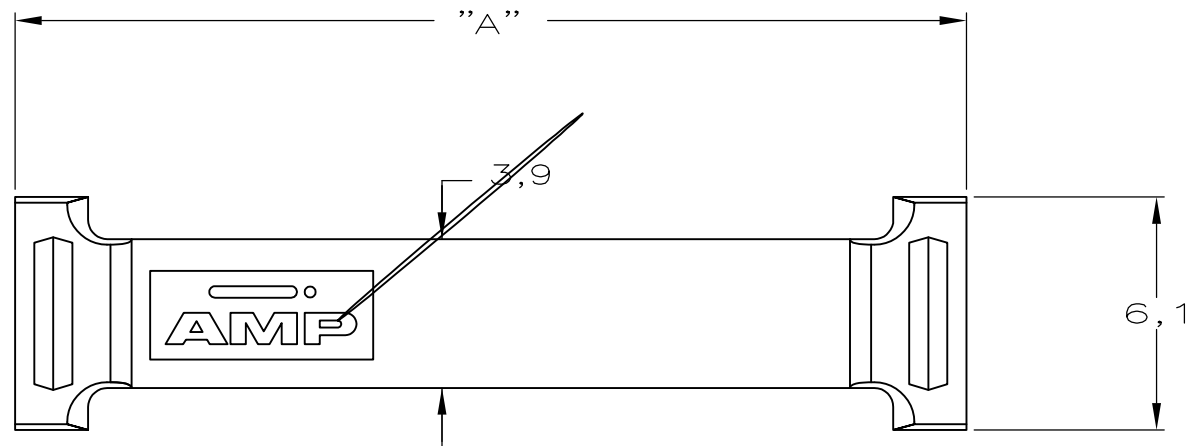
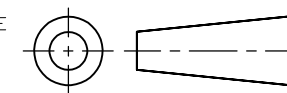

| NR. OF CABLE POS. | NR. OF DUAL POS. | A     | B     | C     | PARTNUMBER |
|-------------------|------------------|-------|-------|-------|------------|
| 64                | 32               | 85,88 | 82,07 | 82,64 | 6-100103-4 |
| 60                | 30               | 80,80 | 76,99 | 77,56 | 6-100103-0 |
| 50                | 25               | 68,10 | 64,29 | 64,86 | 5-100103-0 |
| 44                | 22               | 60,48 | 56,67 | 57,24 | 4-100103-4 |
| 40                | 20               | 55,40 | 51,59 | 52,16 | 4-100103-0 |
| 34                | 17               | 47,78 | 43,97 | 44,54 | 3-100103-4 |
| 30                | 15               | 42,70 | 38,89 | 39,46 | 3-100103-0 |
| 26                | 13               | 37,62 | 33,81 | 34,38 | 2-100103-6 |
| 20                | 10               | 30,00 | 26,19 | 26,76 | 2-100103-0 |
| 16                | 8                | 24,92 | 21,11 | 21,68 | 1-100103-6 |
| 14                | 7                | 22,38 | 18,57 | 19,14 | 1-100103-4 |
| 10                | 5                | 17,30 | 13,49 | 14,06 | 1-100103-0 |

NOTES:

- 1 ASSEMBLED WITH AMP-LATCH MIL-TYPE RECEPT. CONN. (SYMMETRIC COVER)
- 2 250 PIECES PACKED IN A PLASTIC BAG.
- 3 OBSOLETE PARTS: OBSOLETE CIS STREAMLINING PER D.RENAUD/D.SINISI

|               |                   |
|---------------|-------------------|
| GREY RAL 7032 | GLASSFILLED NYLON |
| COLOR         | MATERIAL          |

|                             |                     |                  |                |      |  |          |
|-----------------------------|---------------------|------------------|----------------|------|--|----------|
| CUSTOMER DRAWING            |                     |                  |                |      | FOR REFERENCE ONLY<br>WILL NOT BE UPDATED          |          |
| © COPYRIGHT 19 - BY         |                     |                  |                |      | ALL INTERNATIONAL RIGHTS RESERVED.                 |          |
| THIS DRAWING IS UNPUBLISHED |                     |                  |                |      | RELEASED FOR PUBLICATION _____, 19 _____           |          |
|                             |                     |                  |                |      | NAME   |          |
|                             |                     |                  |                |      | AMP-LATCH MIL-TYPE RECEPT.<br>CONN. STRAIN-RELIEF. |          |
| LTR.                        | REVISION RECORD     | DR.              | CHK.           | DATE | DWG.No.  | REV.LTR. |
| DR.: R.HOGEVEEN.            | CHK.: R.VERSTIJNEN. | APP.: L.V.SOEST. | DATE: 06-08-90 |      | 100103   | C2       |
| DATE: 06-08-90              | DATE: 08-08-90      | DATE: 23-08-90   | SHEET          |      | 1 OF 1   | A3       |

## X-ON Electronics

Largest Supplier of Electrical and Electronic Components

*Click to view similar products for [Headers & Wire Housings](#) category:*

*Click to view products by [TE Connectivity](#) manufacturer:*

Other Similar products are found below :

[892-18-020-10-001101](#) [58102-G61-06LF](#) [582553-1](#) [0009485154](#) [009176003701906](#) [0050291907](#) [LY20-4P-DT1-P1E-BR](#) [02.125.8002.8](#)  
[609-3404](#) [61062-3](#) [61082-181009](#) [622-3653LF](#) [63453-116](#) [636-1030](#) [636-1427](#) [636-3427](#) [636-4007](#) [641938-9](#) [641991-4](#) [644827-2](#) [65817-010LF](#) [65817-015LF](#) [65863-015LF](#) [66207-023LF](#) [67095-007LF](#) [67601157](#) [68645-018](#) [68648-049](#) [70.362.1628.0](#) [70-4210](#) [70-4226B](#) [70-4853B](#) [707-5020](#) [707-5028](#) [71.350.2428.0](#) [71918-208LF](#) [71961-016LF](#) [733-134](#) [733-162](#) [754199-000](#) [760-3052](#) [787-8014-00](#) [79531-3000](#)  
[FCN-360C032-B](#) [FCN-367T-T012/H](#) [FCN-723D010/2](#) [80.063.4001.1](#) [800-90-001-10-001000](#) [800-90-010-10-002000](#) [801-43-002-10-013000](#)