

LOC	DIST	REV	DATE	BY	CHK	APPV
A1	-	1	06AUG2010	DMK	TK	
		2	03JUN2011	KK	HMR	
		3	07JUN2020	SK	FL	
		4	22JUL2020	SK	FL	

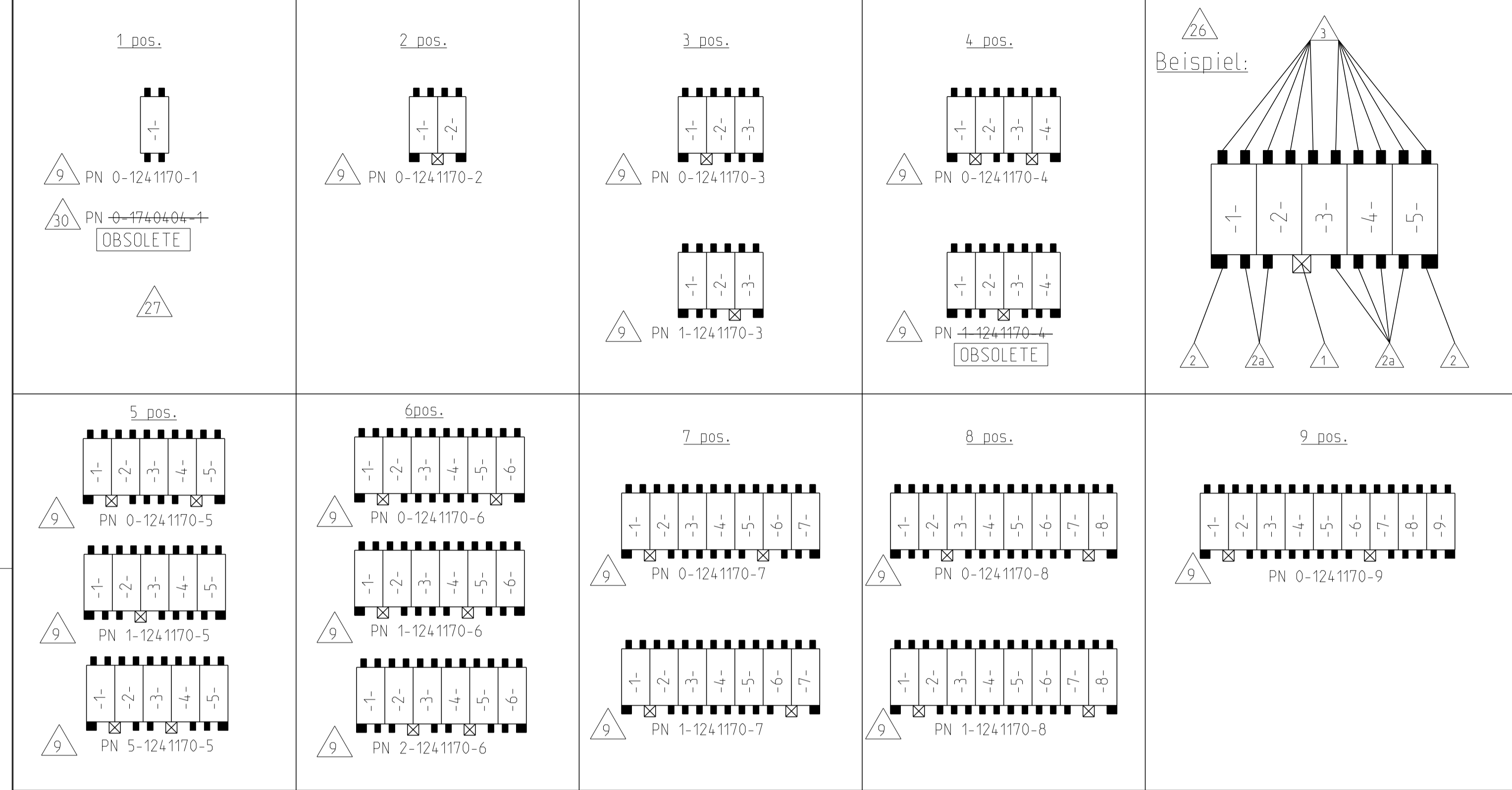

- 1 LOCKING DEVICE BETWEEN CAVITY-NO. Verrastung zwischen Kammer-Nr.
- 2 KEYING RIB ON FIRST AND LAST CAVITY Kodierrippen bei erster und letzter Kammer SEE 2
- 2a TYPICAL KEYING RIB Typische Kodierungsrippen SEE 2
- 3 POLARIZATION RIB (ALL) Polarisierungsrippen (alle) SEE 3
- 4 TE LOGO, MATERIAL DESCRIPTION (PA6.6) TE LOGO, Materialbezeichnung (PA6.6)
- 5 CONNECTOR WITH DOUBLE WIRE FOR WIRE RANGE: (ONLY Y) 0.5-0.5, 0.5-0.75. (SEE APPL. SPEC. NO. 114-18288) Connector mit Doppelanschlag fuer Litze: (nur Y) 0.5-0.5, 0.5-0.75. (siehe Appl. Spec. Nr. 114-18288)
- 6 CONNECTOR WITH SINGLE WIRE FOR WIRE RANGE: 0.35-1.5mm<sup>2</sup> (SEE APPL. SPEC. NO. 114-18288), 0.35-1.0mm<sup>2</sup> SEE 6 Connector mit Einzelanschlag fuer Litze: 0.35-1.5mm<sup>2</sup> (siehe Appl. Spec. Nr. 114-18288), 0.35-1.0mm<sup>2</sup> siehe 6
- 7 STRANDED WIRE BENT TO 90° (ONLY FOR SINGLE WIRE POSSIBLE) Litze 90° gebogen (nur bei Einzelanschlag moeglich)
- 8 TE NO. (HOUSING PN), PRE- AND SUFFIX ONLY TE Nr. (Gehauese PN), nur Vor- und Nachstrichzahl
- 9 CAVITY LOADED WITH CONTACT FOR DGB 0.35-1.0mm<sup>2</sup> (CuZn30 POSTTINNED) Kammer bestueckt mit Kontakt fuer DGB 0.35-1.0mm<sup>2</sup> (CuZn30 posttinnend)
- 10 PACKAGING SEE SPEC. 107-18008 Verpackung siehe Verpackungsanweisung 107-18008
- 11 CONTACT POSITION IN CAVITY Kontaktlage in Kammer
- 12 ASS'Y PN, ONLY PRE- AND SUFFIX. ATTENTION: IDENTIFICATION OF THE COMPLETE ASS'Y PN ONLY POSSIBLE WITH PRE-, SUFFIX, MATERIAL AND CHART. THE COMPLETE ASS'Y PN IS VISIBLE ON PACKAGING Ass'y PN, nur Vor- und Nachstrichzahl. Achtung: Identifizierung der kompletten Ass'y PN nur mit Vor-, Nachstrichzahl, Material und Tabelle moeglich. Die komplette Ass'y PN ist auf der Verpackung ersichtlich.
- 13 NOTE 2, 2a, 3 IN PROCESS CUT OFF INDIVIDUAL Im Prozess beliebig abschneidbar
- 14 SLOT ACCEPT TAB 6.3x0.8, 4.8x0.8 AT DIN e.g. 46244 Kontaktbereich geeignet fuer Tab 6.3x0.8, 4.8x0.8 nach DIN z.B. 46244
- 15 WIRE SUPPORT Drahtunterstuetzung
- 16 REEL CLIPS CAN BE CUT OFF Reelverrastung kann abgeschnitten werden
- 17 MATING STOP Tiefenanschlag
- 18 HSG. CAVITY NO.1 Gehauese Kammer Nr.1
- 19 TE RAST 5 TABHEADER e.g. PN 521382-X TE RAST 5 Tab waene z.B. PN 521382-X
- 20 SPECIAL LOCKING DEVICE ONLY 2POS. HOUSING Besondere Haekengemetrie nur bei 2pol. Gehauese
- 21 MAX. 4 STRANDED WIRE 1.0mm<sup>2</sup> IF USING CONTACT Max. 4 Litzen 1.0mm<sup>2</sup> bei Bestueckung mit Kontakt
- 22 VIEW WITH CLOSED COVER Ansicht mit geschlossenem Deckel gezeichnet
- 23 EXPANSION OF DIMENSION "Y" AFTER TERMINATION BY USING 4 POS. CONNECTORS WITH 1.0mm<sup>2</sup> STRANDED WIRE AND 8 POS. CONNECTORS WITH 0.75mm<sup>2</sup> STRANDED WIRE SEE APPL. SPEC. Aufweitung Mass "Y" nach dem Anschlag bei 4pol. Connectoren mit 1.0mm<sup>2</sup> Litze und bei 8pol. Connectoren mit 0.75mm<sup>2</sup> Litze siehe Appl. Spec.
- 24 FOR DOUBLE WIRE SEE APPL. SPEC. Bei Doppelanschlag siehe Appl. Spec.
- 25 AREA FOR COLOUR MARKING POSSIBLE Platz fuer farbige Markierung moeglich
- 26 KEYING, VIEW AT DIRECTION "Z" Kodierschema: Ansicht in Richtung "Z"
- 27 LOCKING DEVICE INSIDE OF THE HOUSING (ONLY 1POS. HOUSING) Verrastung innerhalb des Gehaueses (nur bei 1pol. Gehauesen)
- 28 EXTENSION OF WALL, EXCLUDING 1POS. HOUSING ATTENTION: CHANGES TO BE IMPLEMENTED ON ALL TOOLS (10A and 16A) Verl. Aengering der Zwischenwand, betrifft nicht 1pol. Variante Achtung: Aenderung in allen Werkzeugen, direkt und indirekt (10A and 16A)
- 29 EXTERNAL WALLS FOR SNAPPING COVER TO BE REMOVED ON 2POS.- 9POS. HOUSINGS Aussere Waende an 2pol. - 9pol. Varianten, um Deckel einzurasten, koennen entfallen
- 30 CAVITY LOADED WITH CONTACT FOR DGB 0.35-1.0mm<sup>2</sup> (CuNiSi POSTSILVERED) Kammer bestueckt mit Kontakt fuer DGB 0.35-1.0mm<sup>2</sup> (CuNiSi postsilvered)
- 31 ATTENTION! NOTE 2, 2a, 3 ARE CURRENTLY BEING CHANGED IN THE TOOLS Achtung! Note 2, 2a, 3 werden zur Zeit im Werkzeug geaendert
- 32 CONNECTION WITH TABHEADER SEE PN C97-52824-1000 Verbindung mit Tab Waene siehe PN C97-52824-1000
- 33 ELASTIC DEFORMATION OUTWARDS IS ACCEPTABLE IN THE MARKED AREA (EXCLUDING 1 POS. CONNECTOR). VERARBEITBARKEIT UND MODULARITAET IST GRANTET. Elastische Verformung nach auen ist im markierten Bereich zulassig (ausser 1 pol. Connector). Verarbeitbarkeit bzw. Anreihbarkeit ist nicht gefaehrdet.
- 34 CONCERNS ONLY 2POS. VERSIONS (1 CHAMFER AT MIDDLE WALL ADDED) Betrifft nur 2 pol. Variante (Fase an mittlerer Rippe hinzu)
- 35 ALTERNATE GEOMETRY IN HOUSING CAVITY IS PERMITTED FOR ALL VERSIONS UNTIL FURTHER NOTICE. SEE SHEET 2 OF 3

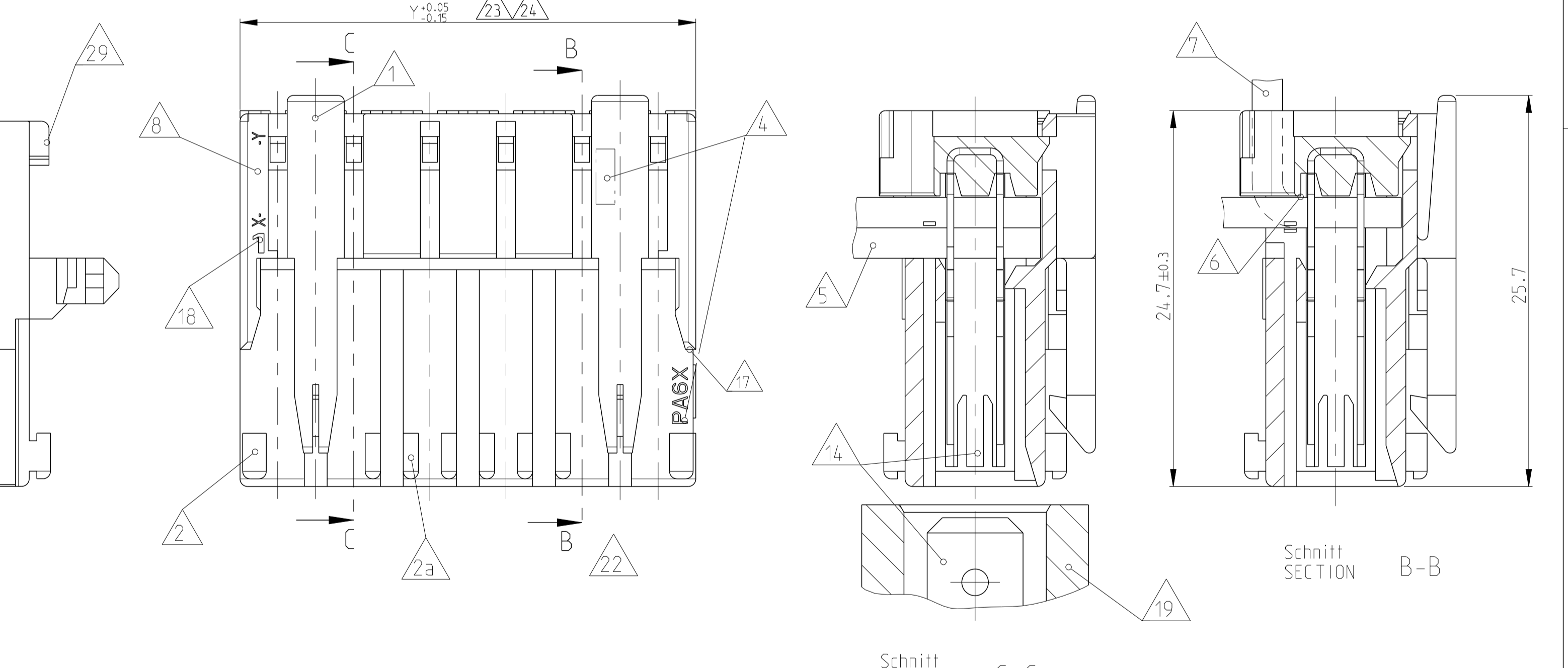
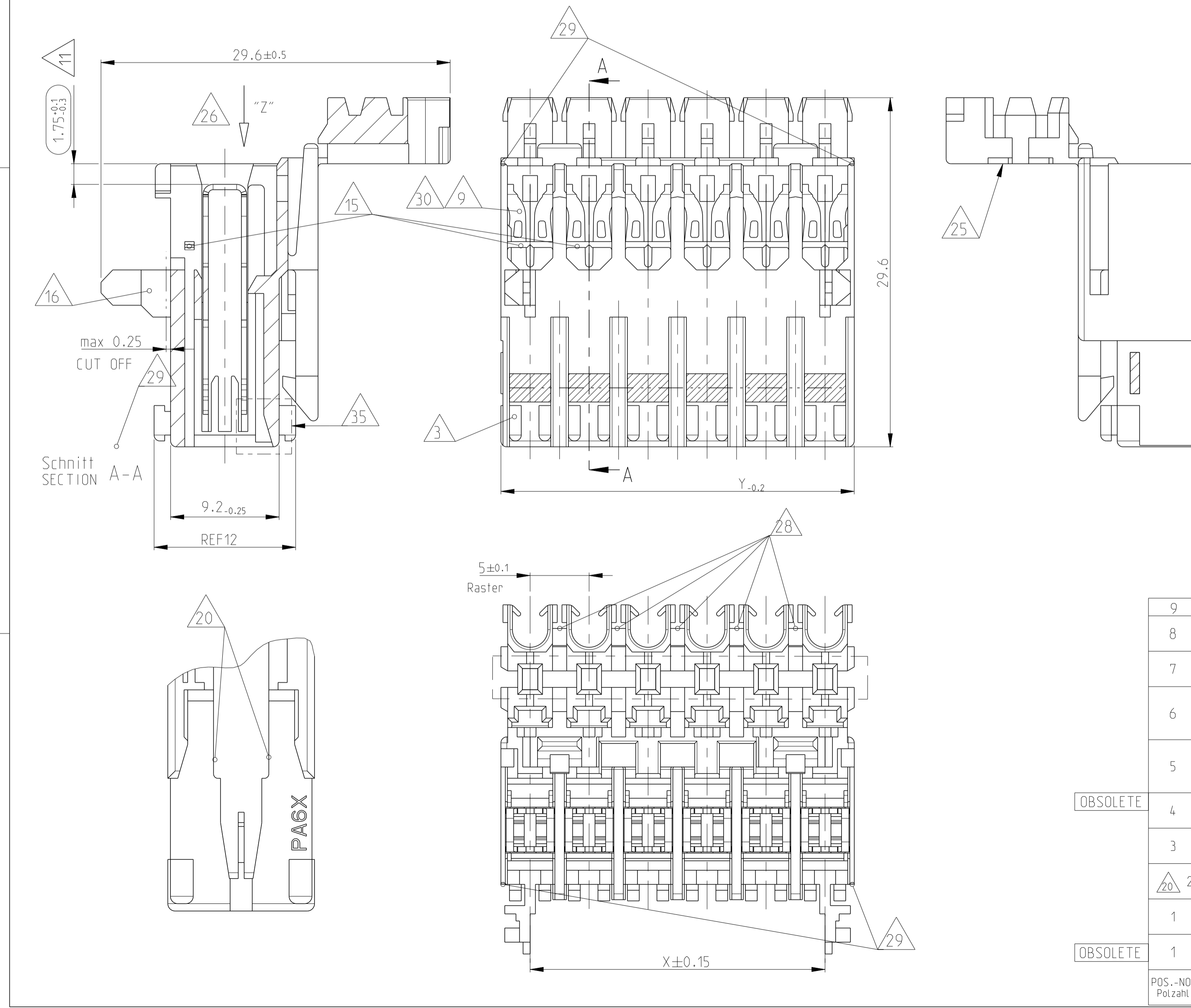

POS.-NO. Polzahl	COLOR Farbe	HOUSING-NO. Gehauese-Nr.	Rev.	ASSY NO. Assy Nr.	Rev.	DIM "X" Mass "X"	DIM "Y" Mass "Y"
9	Natur	0-969519-9	-	0-1241170-9	J	40	44.95
8	Natur	1-969519-8	-	1-1241170-8	J	35	39.95
7	Natur	1-969519-7	-	1-1241170-7	J	30	34.95
6	Natur	2-969519-6	-	2-1241170-6	J	25	29.95
5	Natur	1-969519-5	-	1-1241170-5	J	20	24.95
4	Natur	0-969519-4	-	0-1241170-4	J	15	19.95
3	Natur	1-969519-3	-	1-1241170-3	J	10	14.95
2	Natur	0-969519-2	-	0-1241170-2	K	5	9.95
1	Natur	0-969519-1	-	0-1241170-1	J	-	4.95
1	Natur	0-969519-1	-	0-1740404-1	J	-	4.95

THIS DRAWING IS A CONTROLLED DOCUMENT. DIESES ZEICHNUNGSDOKUMENT IST EIN KONTROLLIERTES DOKUMENT. ANSCHAUEN SIE SICH STRENG AN DIE VERFAHREN FÜR DEN UMGANG MIT KONTROLLIERTEN DOKUMENTEN. THIS DRAWING IS UNPUBLISHED. VERSTÄRKTE UNVERÖFFENTLICHTE ZEICHNUNG. RELEASED FOR PUBLICATION FREI FÜR VERÖFFENTLICHUNG. ALL RIGHTS RESERVED. ALLE RECHTE VORBEHALTEN. MATED WITH POSITION 19.

OWNER: G. Feldmeier, Z2SE999  
 CHECKED: G. Bartsch, Z2SE999  
 PRODUCT SPEC: 108-18652  
 APPLICATION SPEC: 114-18288

MATERIAL: PA 6.6  
 FINISH/SURFACE: -

SCALE: 4:1  
 SHEET: 1 OF 3  
 REV: K6

TE Connectivity  
 1-9pos. AMP multifitting Mark II ASSEMBLY PITCH 5mm TAB VERSION

Customer Drawing / KUNDENZEICHNUNG

ALTERNATE GEOMETRY IN HOUSING CAVITY 35

LOC	DIST	REV	DATE	BY	APPV
A1	-	1	-	-	-

  

REVISIONS		DATE	BY	APPV
NO.	DESCRIPTION			
1	SEE SHEET 1	-	-	-

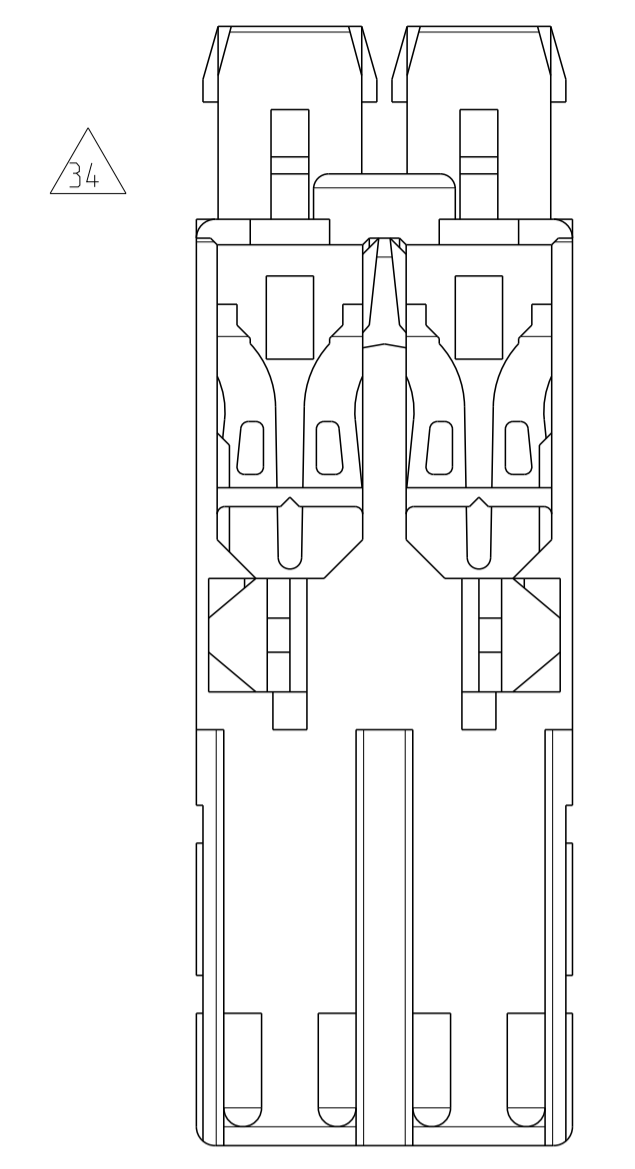
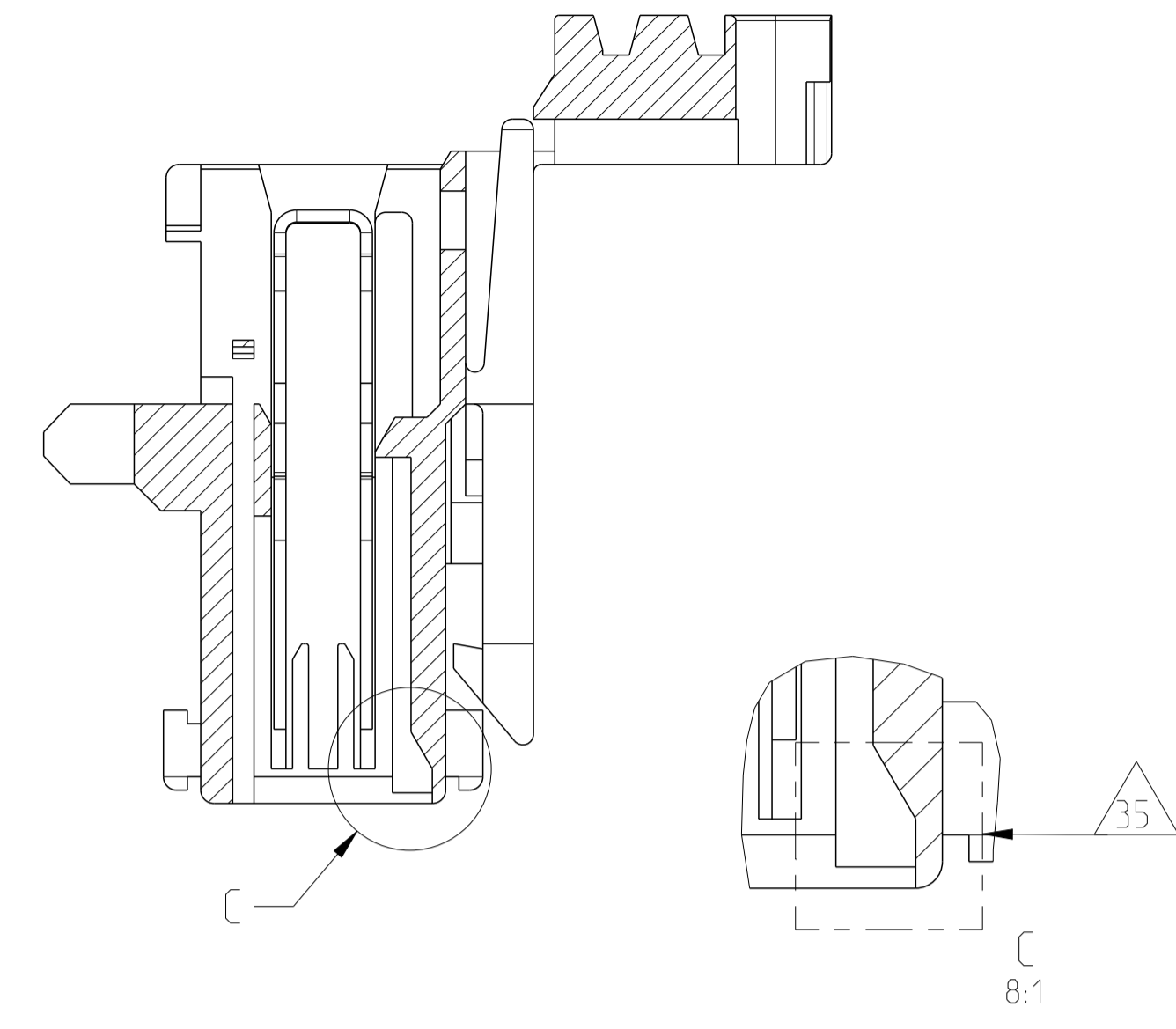
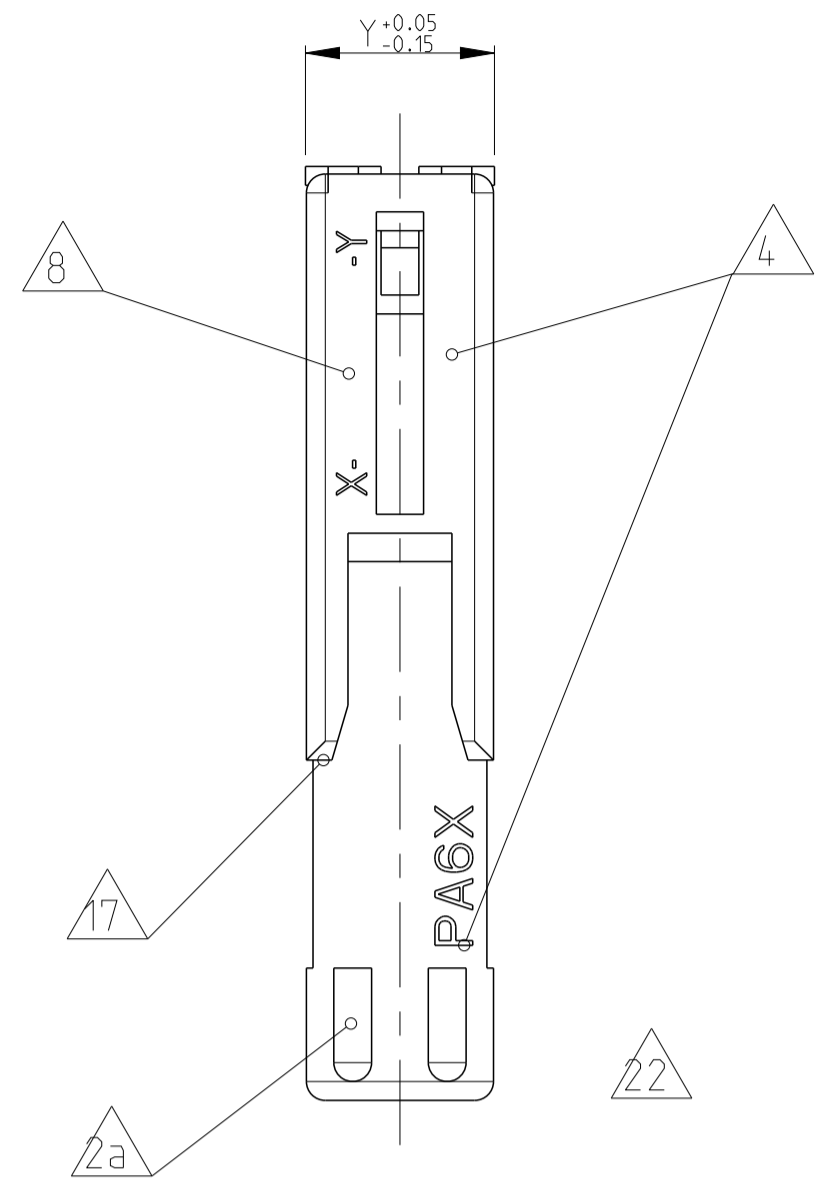
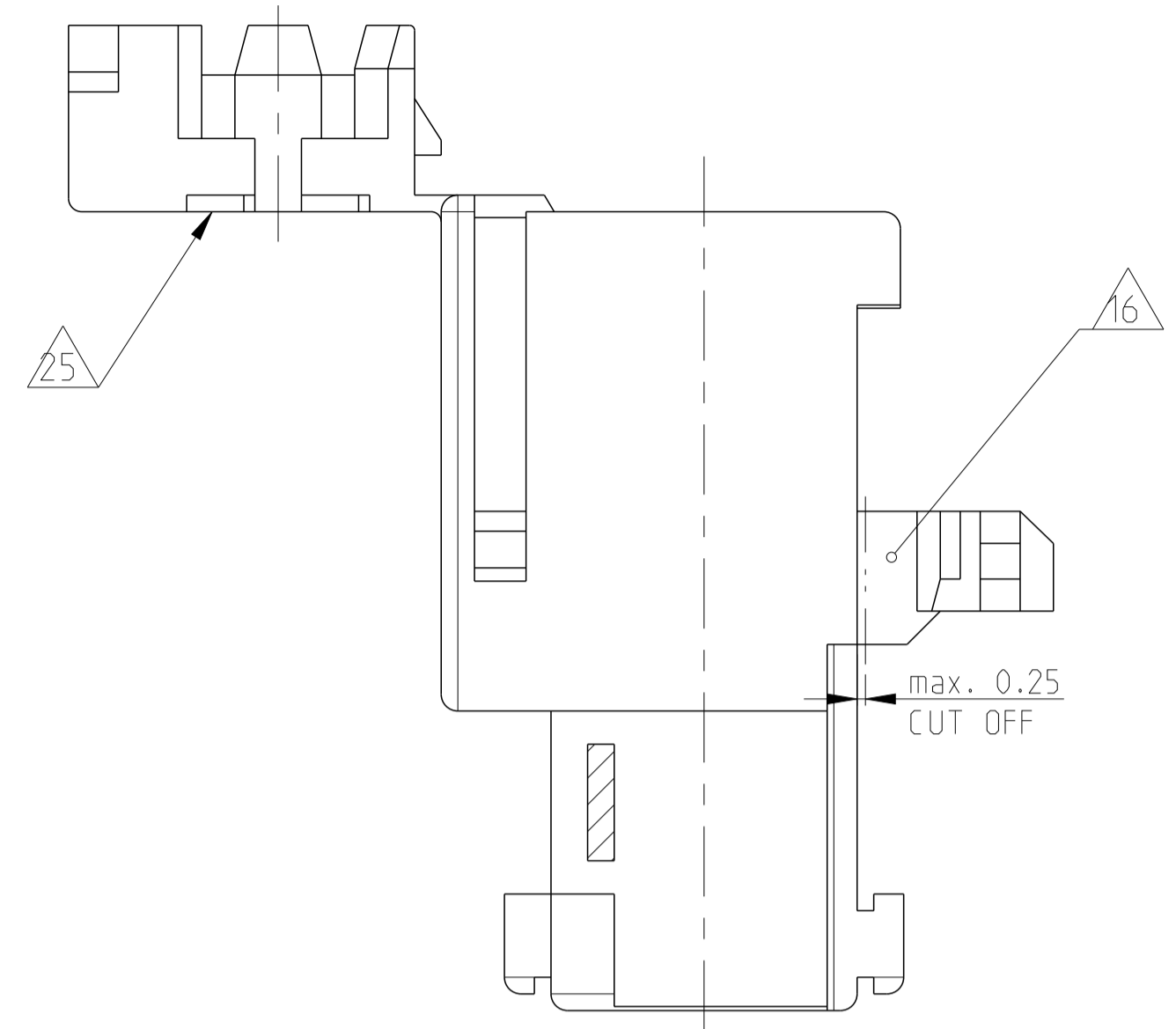
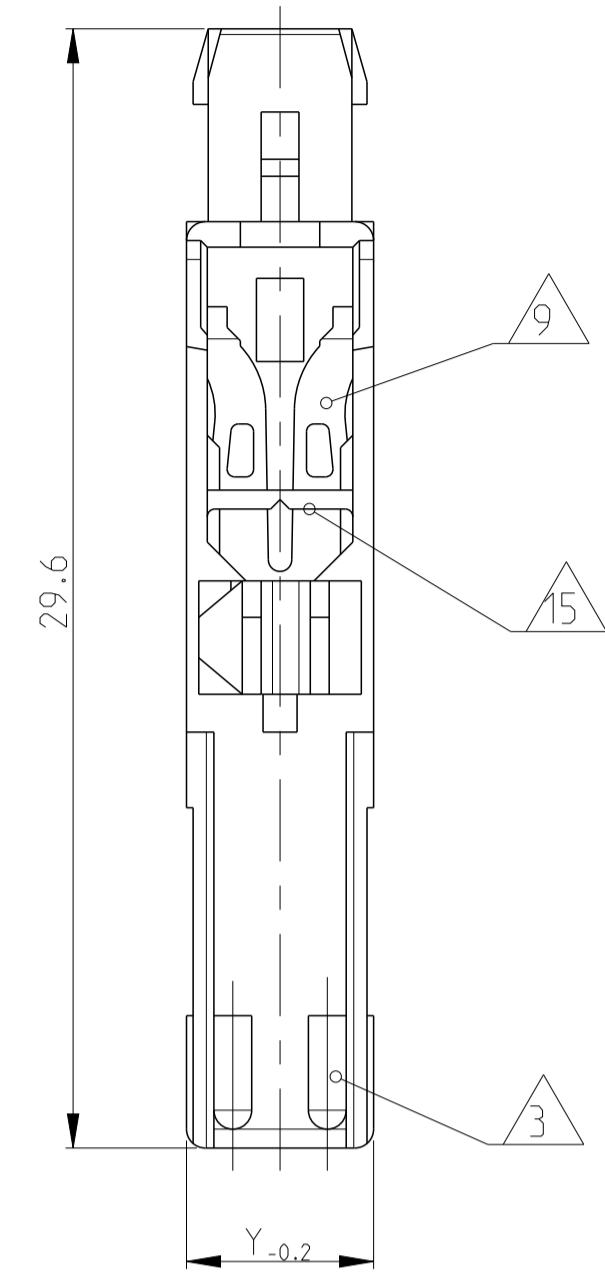

SECTION A-A  
Schnitt

Without Contact  
Ohne Kontakt

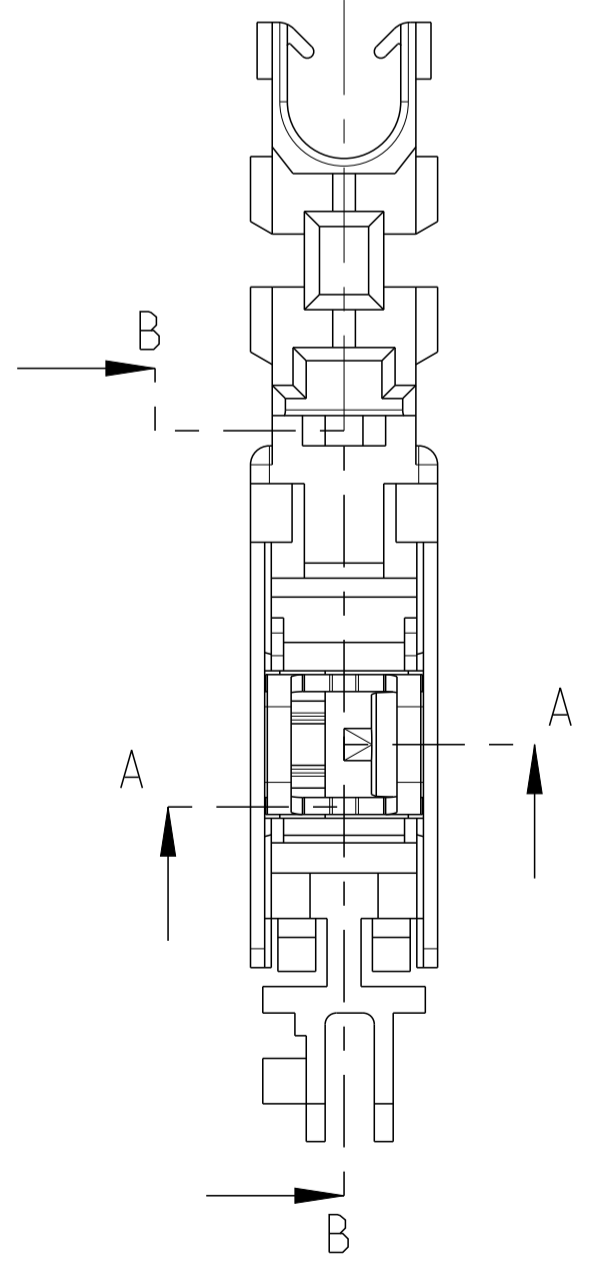

SECTION B-B  
Schnitt

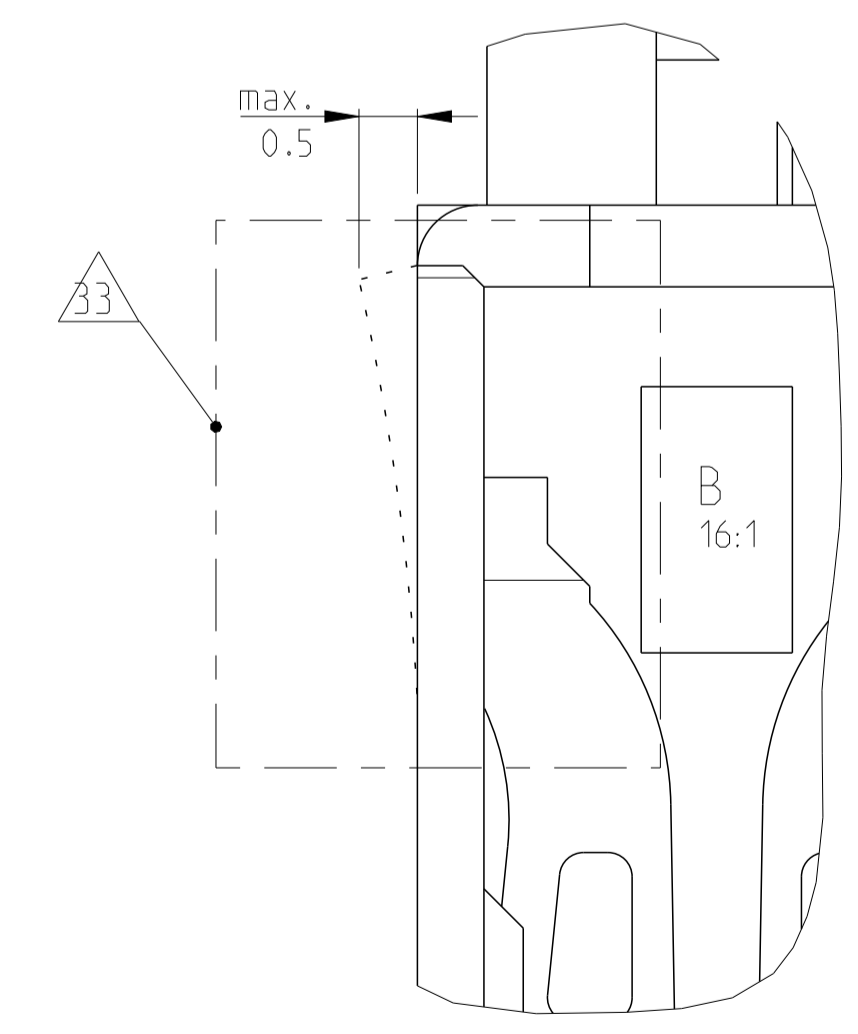
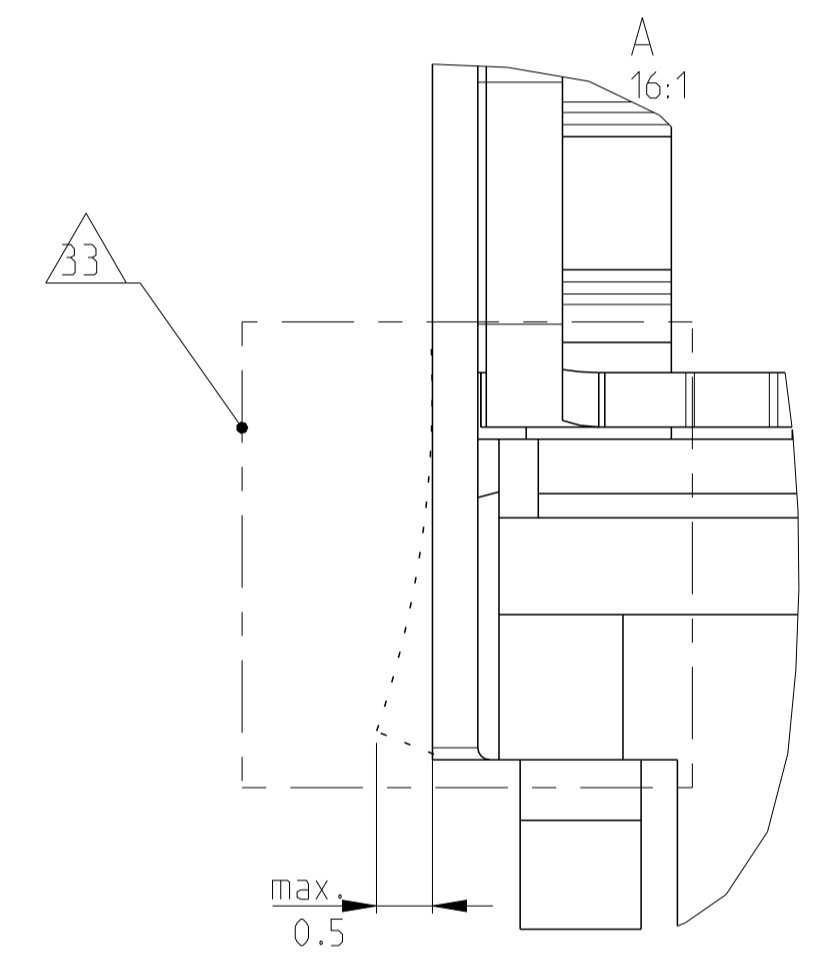
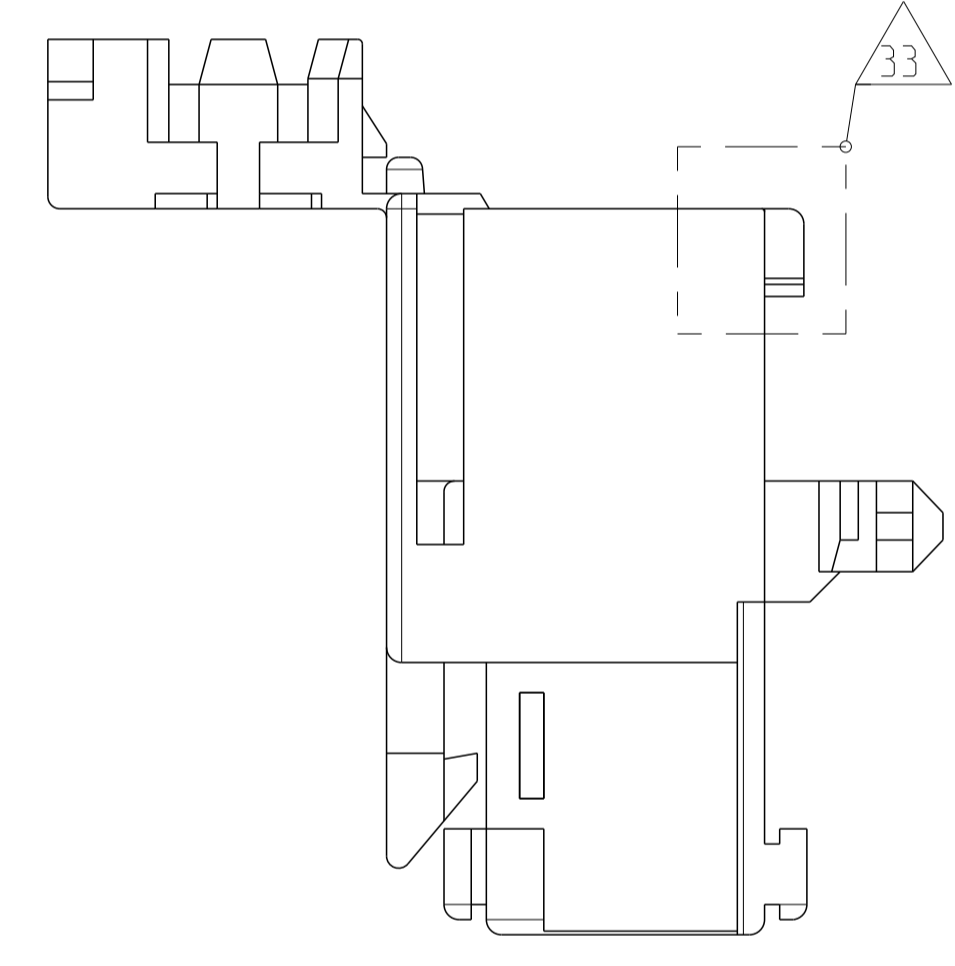
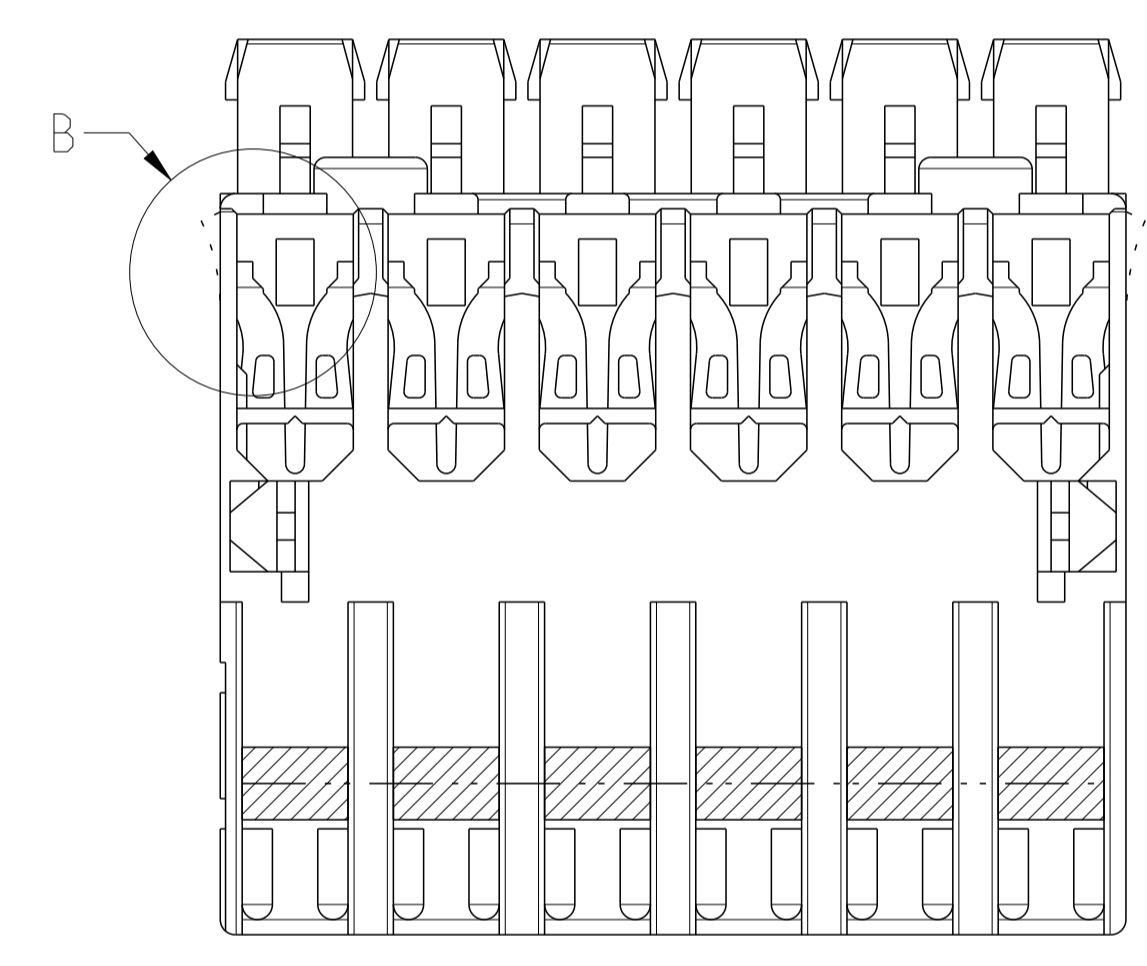
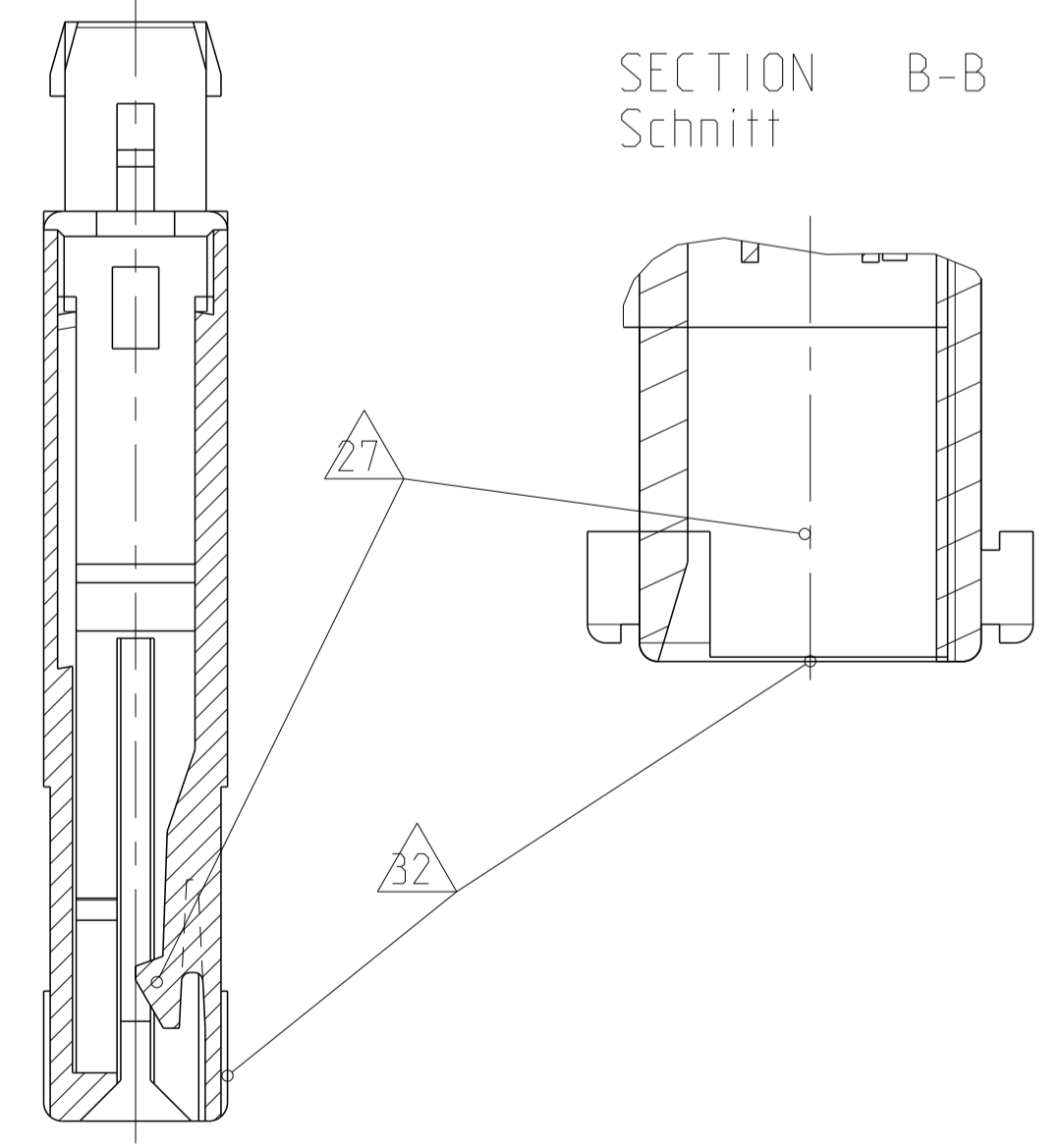

NOTES & TABLES, SEE SHEET 1  
 Notizen & Tabellen, siehe Blatt 1

THIS DRAWING IS A CONTROLLED DOCUMENT. <small>DEUTSCH: DIESE ZEICHNUNG WIRD ALS KONTROLLIERTE DOKUMENT FÜR DIE HERSTELLUNG VON PRODUKTEN VERWENDET. ANDERERWEISE NUR FÜR INFORMATIONEN ZUR VERFÜGBARKEIT DER ZEICHNUNG. DIE ANWENDUNG DIESER ZEICHNUNG FÜR ANWANDUNGSZWECKE WIRD NICHT EMPFOHLEN.</small>		DWN: M. Ottenloch CHK: G. Bartosch APVD: G. Feldmeier	Z2SEP99 Z2SEP99 Z2SEP99	NAME: 1-9pos. AMP multifitting Mark II ASSEMBLY PITCH 5mm TAB VERSION	DATE: 11/14/2008 SCALE: 4:1 SHEET: 2 OF 3 REV: K6
DIMENSIONS: mm TOLERANCES: UNLESS OTHERWISE SPECIFIED: ALL DIMENSIONS	0 PLC ±0.2 1 PLC ± 2 PLC ± 3 PLC ± 4 PLC ± ANGLES/WIRES: ±2° FINISH/SURFACE:	MATERIAL: PA 6.6	WEIGHT: - CUSTOMER DRAWING	DRAWING NO: 00779 DRAWING NO: 1241170	RESTRICTED TO: NUR FÜR

THIS DRAWING IS UNPUBLISHED. RELEASED FOR PUBLICATION  
 © COPYRIGHT ALL RIGHTS RESERVED.

LOC		DIST		REVISIONS			
P	LTN	DESCRIPTION	DATE	DWN	APVD		

1 pos.

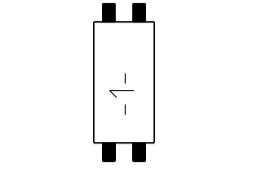

PN 0-2375181-1

2 pos.

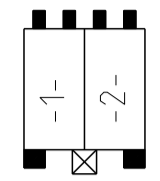

PN 0-2375181-2

3 pos.

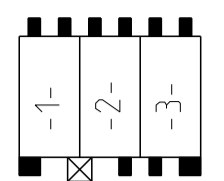

PN 0-2375181-3

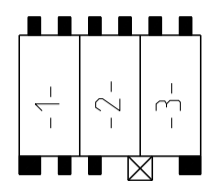

PN 1-2375181-3

△26  
 Beispiel:

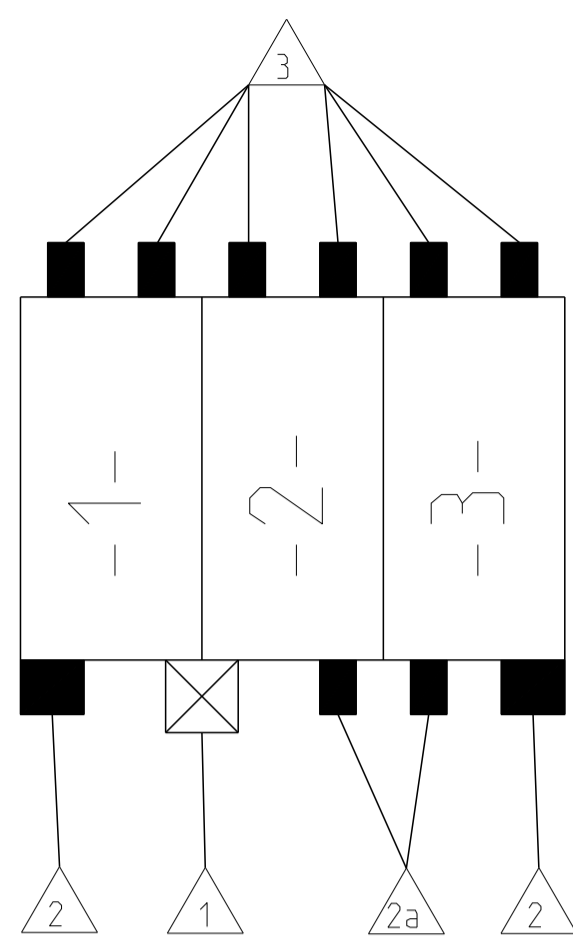

VO + GWT VERSION WITH SILVER PLATING

3	Natur	1-2369968-3	-	1-2375181-3	-	10	14.95		
3	Natur	2369968-3	-	2375181-3	-	10	14.95		
△20 2	Natur	2369968-2	-	2375181-2	-	5	9.95		
1	Natur	2369968-1	-	2375181-1	-	-	4.95		
POS.-NO. Polzahl	COLOR Farbe	HOUSING-NO. Gehäuse-Nr.	△8	Rev.	ASSY NO. Assy Nr.	△40 △12	Rev.	DIM "X" Mass "X"	DIM "Y" Mass "Y"

NOTES & TABLES. SEE SHEET 1  
 Notizen & Tabellen, siehe Blatt 1

THIS DRAWING IS A CONTROLLED DOCUMENT.		DWN				
DIMENSIONS:		CHK				
	TOLERANCES UNLESS OTHERWISE SPECIFIED:	APVD	NAME			
	0 PLC ±	PRODUCT SPEC				
	1 PLC ±	APPLICATION SPEC				
	2 PLC ±					
MATERIAL	FINISH	WEIGHT	SIZE	CAGE CODE	DRAWING NO	RESTRICTED TO
			A 1			
			SCALE	SHEET	OF	REV

## X-ON Electronics

Largest Supplier of Electrical and Electronic Components

*Click to view similar products for [Headers & Wire Housings](#) category:*

*Click to view products by [TE Connectivity](#) manufacturer:*

Other Similar products are found below :

[892-18-020-10-001101](#) [58102-G61-06LF](#) [582553-1](#) [0009485154](#) [009176003701906](#) [0050291907](#) [LY20-4P-DT1-P1E-BR](#) [02.125.8002.8](#)  
[609-3404](#) [61062-3](#) [61082-181009](#) [622-3653LF](#) [63453-116](#) [636-1030](#) [636-1427](#) [636-3427](#) [636-4007](#) [641938-9](#) [641991-4](#) [644827-2](#) [65817-](#)  
[010LF](#) [65817-015LF](#) [65863-015LF](#) [66207-023LF](#) [67095-007LF](#) [67601157](#) [68645-018](#) [68648-049](#) [70.362.1628.0](#) [70-4210](#) [70-4226B](#) [70-](#)  
[4853B](#) [707-5020](#) [707-5028](#) [71.350.2428.0](#) [71918-208LF](#) [71961-016LF](#) [733-134](#) [733-162](#) [754199-000](#) [760-3052](#) [787-8014-00](#) [79531-3000](#)  
[FCN-360C032-B](#) [FCN-367T-T012/H](#) [FCN-723D010/2](#) [80.063.4001.1](#) [800-90-001-10-001000](#) [800-90-010-10-002000](#) [801-43-002-10-013000](#)