

- 20 POSITION CONNECTOR ASSEMBLY SHOWN.
- MOLDED PARTS: THERMOPLASTIC, UL94V-0 RATED, COLOR BLACK. CONTACTS: PHOSPHOR BRONZE.
- CONTACTS: 0.00038[.00015] MIN GOLD ON MATING AREA, GOLD FLASH ON TERMINATION END, ALL OVER 0.00127[.00050] MIN NICKEL ON ENTIRE CONTACT.
- POLARIZER FEATURE DOES NOT EXIST ON POSITION #1 END FOR 14 POSITION ASSEMBLIES AND SMALLER.
- POLARIZER FEATURE DOES NOT EXIST ON THIS END FOR 6 POSITION ASSEMBLIES.
- FOR TERMINATION OF 26 OR 28 AWG STRANDED OR SOLID PVC INSULATED FLAT RIBBON CABLE. SEE TE CONNECTIVITY DRAWINGS 57034 (26 AWG) OR 57040 (28 AWG) FOR DETAILS.
- STRAIN RELIEF PACKAGED SEPARATELY AND SHIPPED WITH ASSEMBLY.

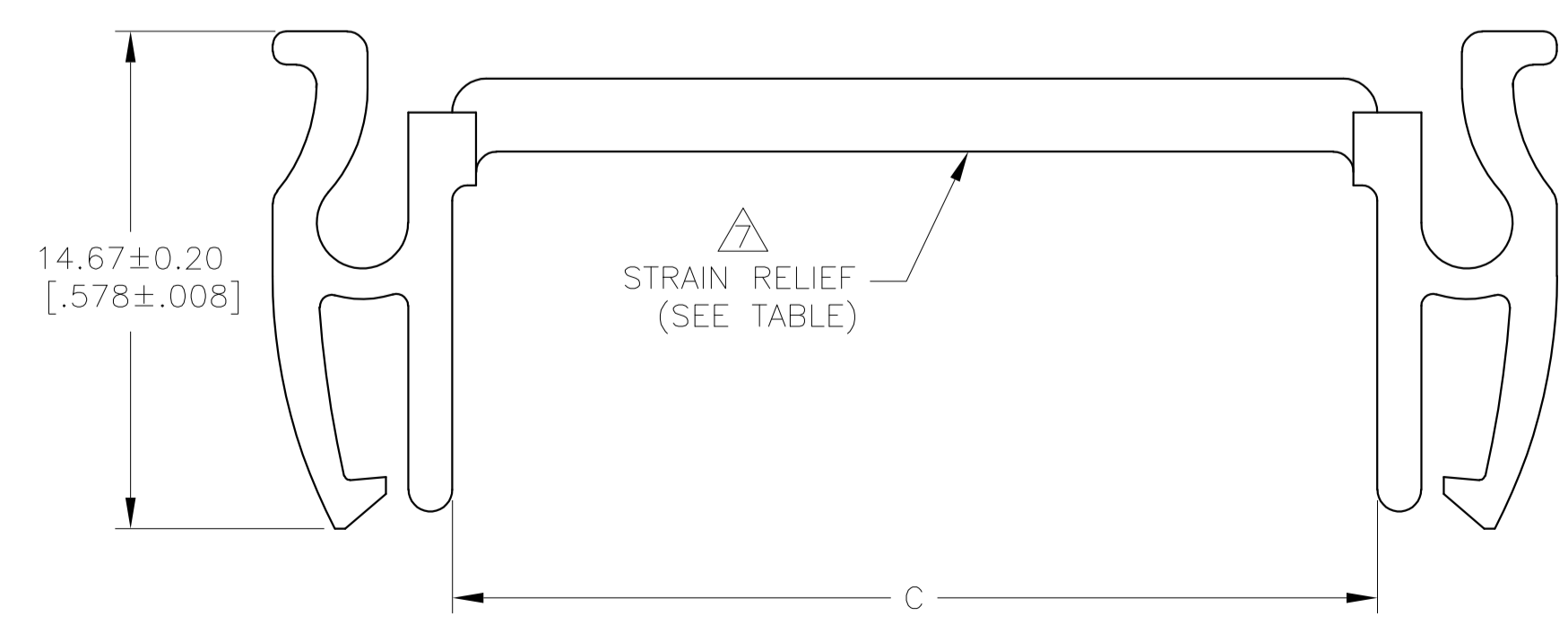
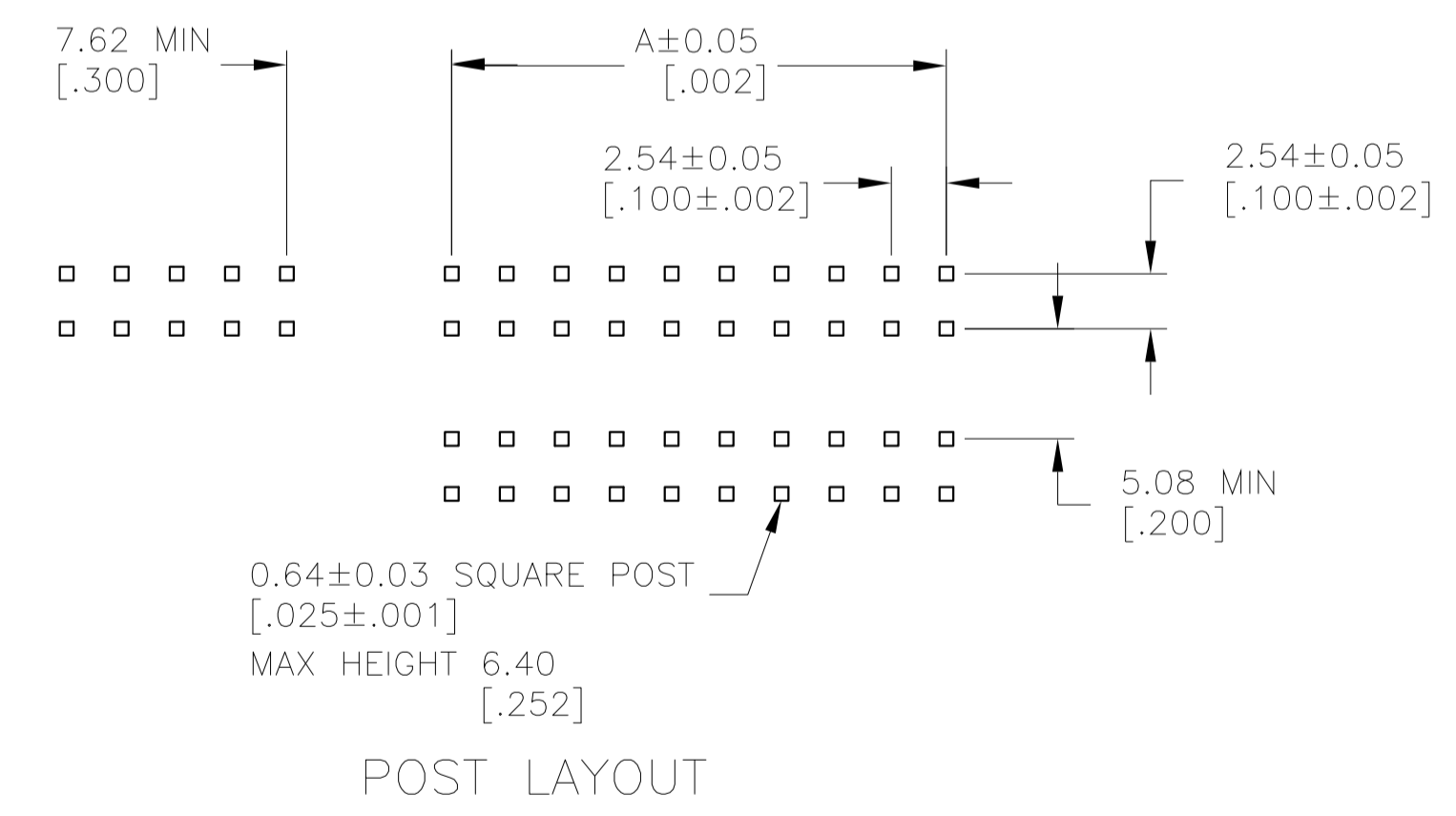
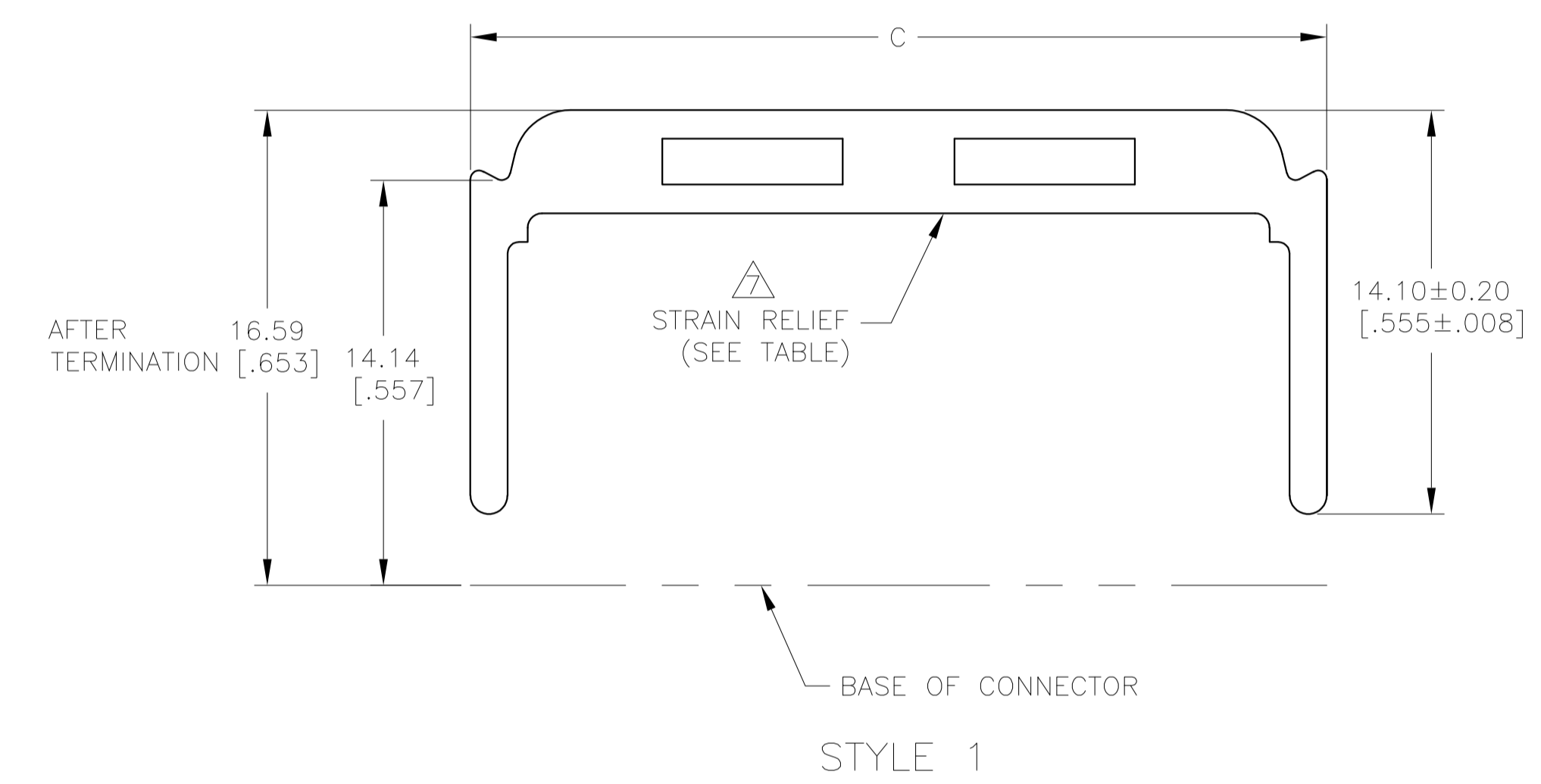
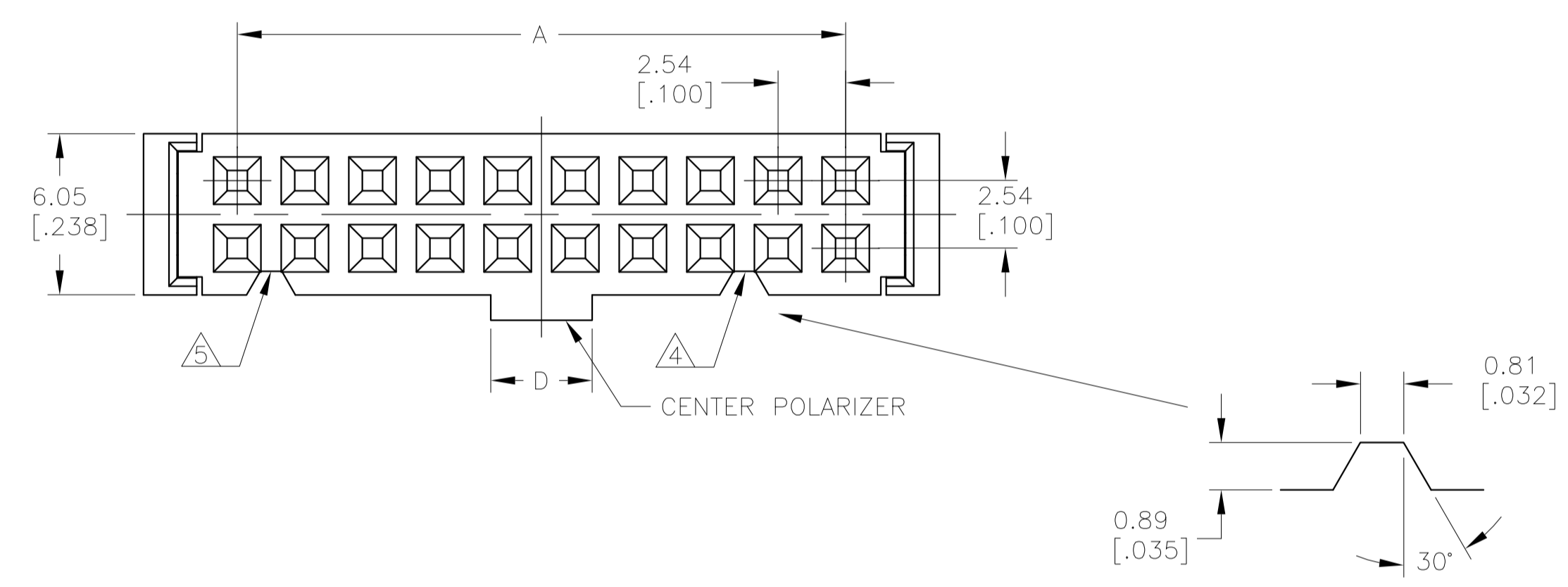
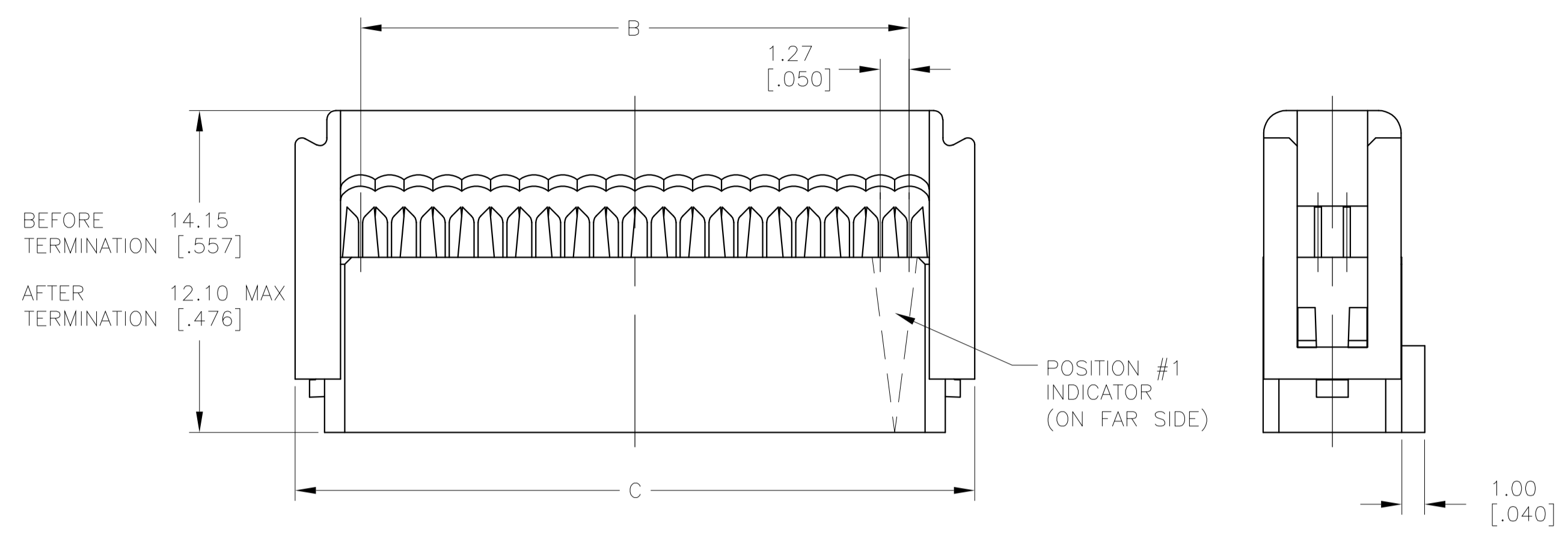

	STYLE	D	C	B	A	NUMBER OF POSITIONS	T&B PART NUMBER (REFERENCE)	PART NUMBER
OBSOLETE	STYLE 2	3.80[.150]	22.22[.875]	19.05[.750]	17.78[.700]	16	636-1641LSLF	2-1658528-7
	STYLE 2	3.80[.150]	19.68[.775]	16.51[.650]	15.24[.600]	14	636-1441LSLF	2-1658528-6
	STYLE 2	3.20[.126]	14.60[.575]	11.43[.450]	10.16[.400]	10	636-1041LSLF	2-1658528-5
	STYLE 2	1.90[.075]	9.52[.375]	6.35[.250]	5.08[.200]	6	636-0641LSLF	2-1658528-4
	STYLE 1	3.80[.150]	85.78[3.377]	80.01[3.150]	78.74[3.100]	64	636-6441LF	2-1658528-3
	NONE	3.80[.150]	85.78[3.377]	80.01[3.150]	78.74[3.100]	64	636-6430LF	2-1658528-2
OBSOLETE	STYLE 1	3.80[.150]	80.70[3.177]	74.93[2.950]	73.66[2.900]	60	636-6041LF	1658528-9
OBSOLETE	NONE	3.80[.150]	80.70[3.177]	74.93[2.950]	73.66[2.900]	60	636-6030LF	2-1658528-1
	STYLE 1	3.80[.150]	68.00[2.677]	62.23[2.450]	60.95[2.400]	50	636-5041LF	1658528-8
	NONE	3.80[.150]	68.00[2.677]	62.23[2.450]	60.95[2.400]	50	636-5030LF	2-1658528-0
	STYLE 1	3.80[.150]	55.30[2.177]	49.53[1.950]	48.26[1.900]	40	636-4041LF	1-1658528-9
	NONE	3.80[.150]	55.30[2.177]	49.53[1.950]	48.26[1.900]	40	636-4030LF	1658528-7
	STYLE 1	3.80[.150]	47.68[1.877]	41.91[1.650]	40.64[1.600]	34	636-3441LF	1658528-6
	NONE	3.80[.150]	47.68[1.877]	41.91[1.650]	40.64[1.600]	34	636-3430LF	1-1658528-8
	STYLE 1	3.80[.150]	37.52[1.477]	31.75[1.250]	30.48[1.200]	26	636-2641LF	1658528-5
	NONE	3.80[.150]	37.52[1.477]	31.75[1.250]	30.48[1.200]	26	636-2630LF	1-1658528-7
	NONE	3.80[.150]	34.98[1.377]	29.21[1.150]	27.94[1.100]	24	636-2430LF	1-1658528-6
	STYLE 1	3.80[.150]	29.90[1.177]	24.13[.950]	22.86[.900]	20	636-2041LF	1658528-4
	NONE	3.80[.150]	29.90[1.177]	24.13[.950]	22.86[.900]	20	636-2030LF	1-1658528-5
OBSOLETE	STYLE 1	3.80[.150]	24.82[.977]	19.05[.750]	17.78[.700]	16	636-1641LF	1658528-3
	NONE	3.80[.150]	24.82[.977]	19.05[.750]	17.78[.700]	16	636-1630LF	1-1658528-3
OBSOLETE	STYLE 1	3.80[.150]	22.28[.877]	16.51[.650]	15.24[.600]	14	636-1441LF	1-1658528-4
	NONE	3.80[.150]	22.28[.877]	16.51[.650]	15.24[.600]	14	636-1430LF	1-1658528-2
	STYLE 1	3.20[.126]	17.20[.677]	11.43[.450]	10.16[.400]	10	636-1041LF	1658528-2
	NONE	3.20[.126]	17.20[.677]	11.43[.450]	10.16[.400]	10	636-1030LF	1-1658528-1
OBSOLETE	STYLE 1	1.90[.075]	12.12[.477]	6.35[.250]	5.08[.200]	6	636-0641LF	1658528-1
	NONE	1.90[.075]	12.12[.477]	6.35[.250]	5.08[.200]	6	636-0630LF	1-1658528-0
STRAIN RELIEF TYPE		D	C	B	A	NUMBER OF POSITIONS	T&B PART NUMBER (REFERENCE)	PART NUMBER

ELECTRICAL PROPERTIES	
CURRENT RATING	1 AMP
INSULATION RESISTANCE	>1 x 10 <sup>9</sup> OHMS @ 500 VDC
DWV	>500 VRMS AT SEA LEVEL
ENVIRONMENTAL PROPERTIES	
TEMPERATURE RATING	-55°C TO 125°C

THIS DRAWING IS A CONTROLLED DOCUMENT.

DIMENSIONS: INCHES	TOLERANCES UNLESS OTHERWISE SPECIFIED:	DIN J GERACE 17SEP04	APVD M WALMSLEY 17SEP04
0 PLC ± -	1 PLC ± -	2 PLC ± -	3 PLC ± 0.1X(.005)
4 PLC ± -	ANGLES ± -		

MATERIAL: FINISH:

STE TE Connectivity

CONNECTOR ASSEMBLY, FEMALE SOCKET TRANSITION, 636 SERIES

SIZE: A1 CASE CODE: 00779 DRAWING NO: 1658528

CUSTOMER DRAWING SCALE: 5:1 SHEET 1 OF 1 REV: F1

## X-ON Electronics

Largest Supplier of Electrical and Electronic Components

*Click to view similar products for [Headers & Wire Housings](#) category:*

*Click to view products by [TE Connectivity](#) manufacturer:*

Other Similar products are found below :

[892-18-020-10-001101](#) [58102-G61-06LF](#) [582553-1](#) [0009485154](#) [009176003701906](#) [0050291907](#) [LY20-4P-DT1-P1E-BR](#) [02.125.8002.8](#)  
[609-3404](#) [61062-3](#) [61082-181009](#) [622-3653LF](#) [63453-116](#) [636-1030](#) [636-1427](#) [636-3427](#) [636-4007](#) [641938-9](#) [641991-4](#) [644827-2](#) [65817-](#)  
[010LF](#) [65817-015LF](#) [65863-015LF](#) [66207-023LF](#) [67095-007LF](#) [67601157](#) [68645-018](#) [68648-049](#) [70.362.1628.0](#) [70-4210](#) [70-4226B](#) [70-](#)  
[4853B](#) [707-5020](#) [707-5028](#) [71.350.2428.0](#) [71918-208LF](#) [71961-016LF](#) [733-134](#) [733-162](#) [754199-000](#) [760-3052](#) [79531-3000](#) [FCN-](#)  
[360C032-B](#) [FCN-367T-T012/H](#) [FCN-723D010/2](#) [80.063.4001.1](#) [800-90-010-10-002000](#) [801-43-002-10-013000](#) [801-43-006-10-002000](#)  
[801-93-011-10-001000](#)