

LOC		DIST		REVISIONS			
P	LTR	DESCRIPTION		DATE	DWN	APVD	
DW	J	REVISED PER ECO-19-018195		20OCT2020	D.S	H.L	

- NOTE:
- MATERIAL:  
 HOUSING: PA9T, UL94 V-0, COLOR: (SEE TABLE).  
 CONTACTS: BRASS.  
 CAP: LCP UL94 V-0, COLOR :BLACK.
  - FINISH:  
 CONTACTS: 3.05um [120u"] MIN. MATTE-TIN.  
 1.27um [50u"] MIN. NICKEL UNDERPLATED ALL OVER.
  - WAVE SOLDER CAPABLE TO 265°C PER TEST SPEC.  
 109-202, CONDITION B.
  - NO TE LOGO AND DATE CODE ON THE PRODUCT WITH 4 POS.
  - THE KEY IDENTIFIED WAS SHOWN ON PAGE 5.

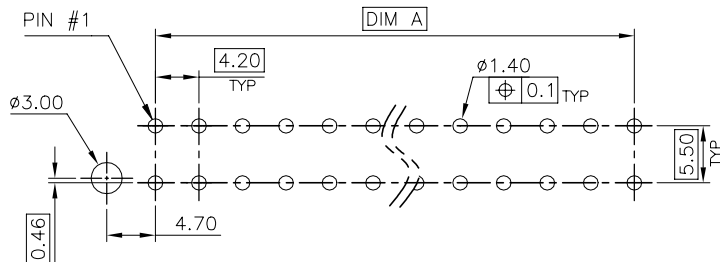
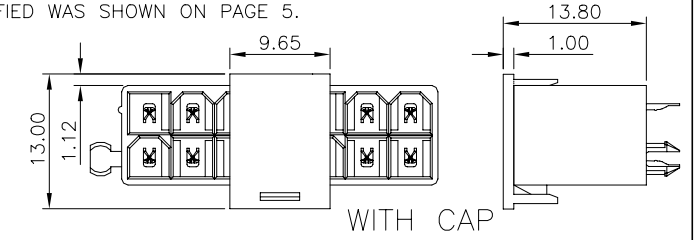
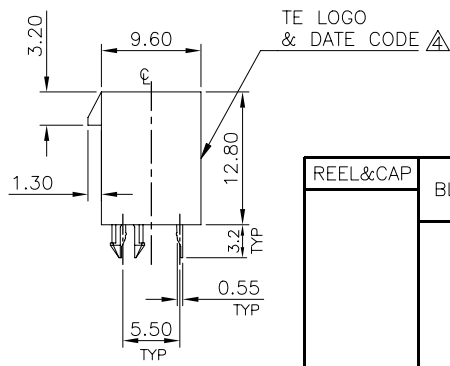
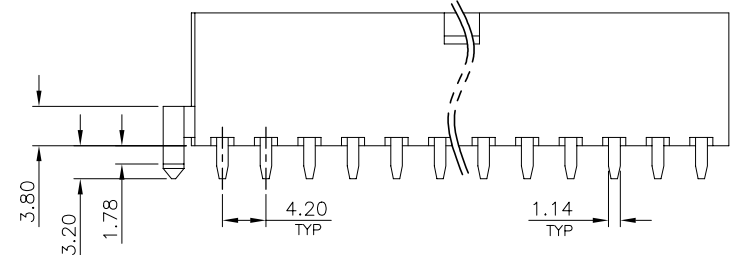
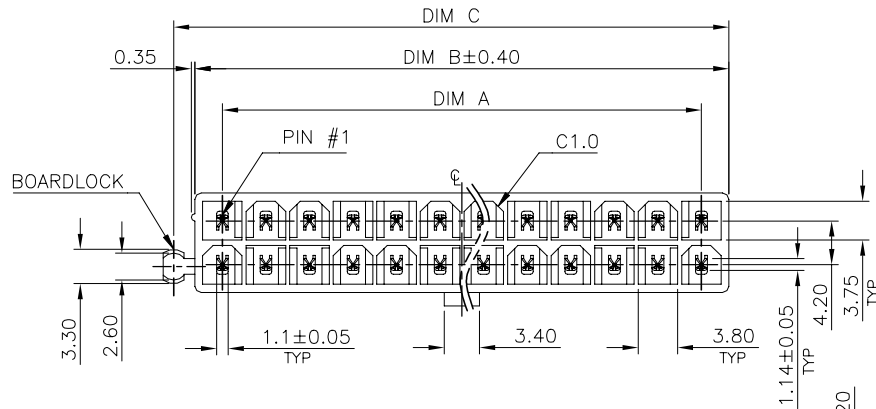

RECOMMENDED PCB LAYOUT  
 TOLERANCE: ±0.05 T=1.6mm

ONE BOARDLOCK  
 (LEFT)

SUPERSEDED TO 1-1775099-3  
 SUPERSEDED TO 1-1775099-2  
 OBSOLETE

REEL&CAP	BLACK PA9T	3.11	25.2	30.5	32.55	14	6-1775099-9
TRAY	IVORY PA9T	1.52	8.4	13.7	15.75	6	6-1775099-6
		5.40	46.2	51.5	53.55	24	1-1775099-3
		1.13	4.2	9.5	11.55	4	1-1775099-2
		4.30	37.8	43.1	45.15	20	1-1775099-1
		3.90	33.6	38.9	40.95	18	1-1775099-0
		3.11	25.2	30.5	32.55	14	1775099-9
		2.71	21.0	26.3	28.35	12	1775099-8
		2.31	16.8	22.1	24.15	10	1775099-7
		1.52	8.4	13.7	15.75	6	1775099-6
		1.92	12.6	17.9	19.95	8	1775099-5
PACKAGE	IVORY PA9T	5.40	46.2	51.5	53.55	24	1775099-4
		1.13	4.2	9.5	11.55	4	1775099-3
PACKAGE	TRANSPARENCY PA9T	5.40	46.2	51.5	53.55	24	1775099-2
		1.13	4.2	9.5	11.55	4	1775099-1
PACKAGE	HSG COLOR & MATERIAL	WEIGHT	DIM A	DIM B	DIM C	POS.	PART NUMBER

THIS DRAWING IS A CONTROLLED DOCUMENT.

DWN B. HSING	15JUL2009	TE Connectivity ATX POWER CONNECTOR 4.2mm PITCH, VERTICAL, DIP TYPE
CHK S. CHIEN	15JUL2009	
APVD W. KODAMA	15JUL2009	
NAME		
PRODUCT SPEC	108-57560	SIZE A3 CAGE CODE 00779 C=1775099 RESTRICTED TO
APPLICATION SPEC	SEE TABLE	
MATERIAL	SEE NOTE	SCALE
FINISH	SEE NOTE	SHEET 1 OF 7
CUSTOMER DRAWING		REV J

LOC		DIST		REVISIONS			
P	LTR	DESCRIPTION		DATE	DWN	APVD	
DW				SEE SHEET 1.			

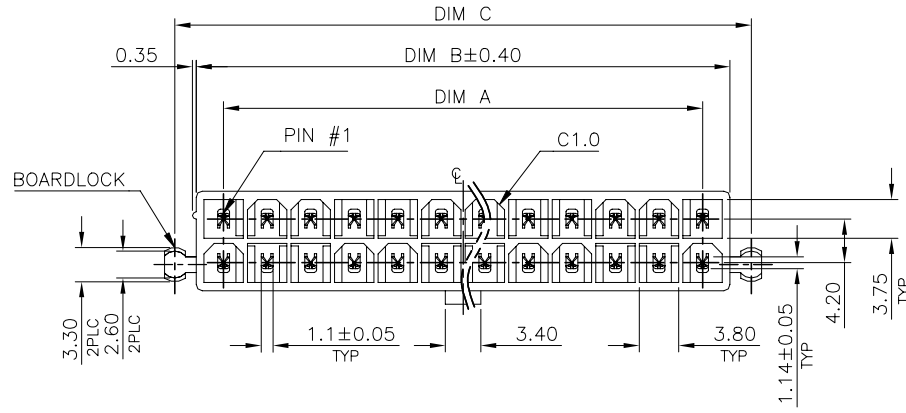

- NOTE:
- MATERIAL:  
HOUSING: PA9T, UL94 V-0, COLOR: (SEE TABLE).  
CONTACTS: BRASS.
  - FINISH:  
CONTACTS: 3.05um [120u"] MIN. MATTE-TIN.  
1.27um [50u"] MIN. NICKEL UNDERPLATED ALL OVER.
  - WAVE SOLDER CAPABLE TO 265°C PER TEST SPEC.  
109-202, CONDITION B.
  - NO TE LOGO AND DATE CODE ON THE PRODUCT WITH 4 POS.
  - THE KEY IDENTIFIED WAS SHOWN ON PAGE 5.
  - PACKING WITH TRAY.

TWO BOARDLOCK

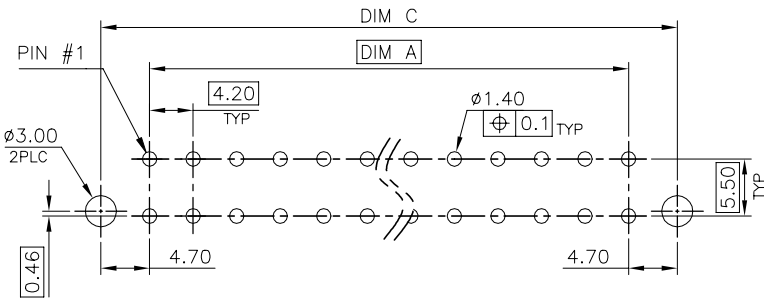
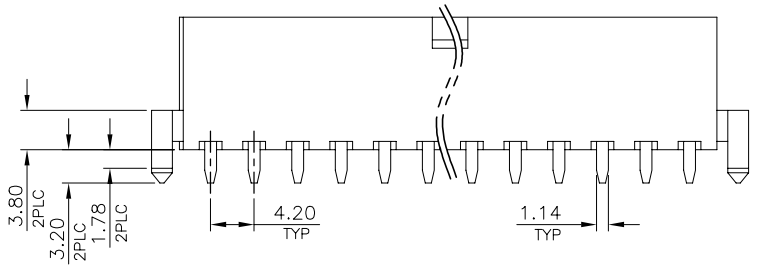
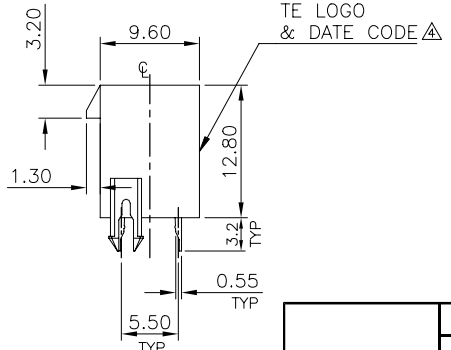

RECOMMENDED PCB LAYOUT  
 TOLERANCE: ±0.05 T=1.6mm

IVORY PA9T	3.54	29.4	34.7	38.8	16	2-1775099-9
	5.43	46.2	51.5	55.6	24	2-1775099-8
	4.33	37.8	43.1	47.2	20	2-1775099-7
	3.93	33.6	38.9	43.0	18	2-1775099-6
	3.14	25.2	30.5	34.6	14	2-1775099-5
	2.74	21.0	26.3	30.4	12	2-1775099-4
	2.34	16.8	22.1	26.2	10	2-1775099-3
	1.95	12.6	17.9	22.0	8	2-1775099-2
	1.55	8.4	13.7	17.8	6	2-1775099-1
1.16	4.2	9.5	13.6	4	2-1775099-0	
HSG COLOR & MATERIAL	WEIGHT	DIM A	DIM B	DIM C	POS.	PART NUMBER

THIS DRAWING IS A CONTROLLED DOCUMENT.

DIMENSIONS: mm	TOLERANCES UNLESS OTHERWISE SPECIFIED:	DWN	TE Connectivity NAME ATX POWER CONNECTOR 4.2mm PITCH, VERTICAL, DIP TYPE			
	0 PLC ± -	CHK				
	1 PLC ± 0.3	APVD				
	2 PLC ± 0.2	PRODUCT SPEC				
MATERIAL	FINISH	APPLICATION SPEC	SIZE	CAGE CODE	DRAWING NO	RESTRICTED TO
		WEIGHT	A3	00779	C=1775099	
CUSTOMER DRAWING			SCALE	SHEET	2 OF 7	REV J

THIS DRAWING IS UNPUBLISHED.

RELEASED FOR PUBLICATION

© COPYRIGHT 2010

BY TYCO ELECTRONICS CORPORATION.

ALL RIGHTS RESERVED.

LOC DW DIST

REVISIONS

P	LTR	DESCRIPTION	DATE	DWN	APVD
		SEE SHEET 1.			

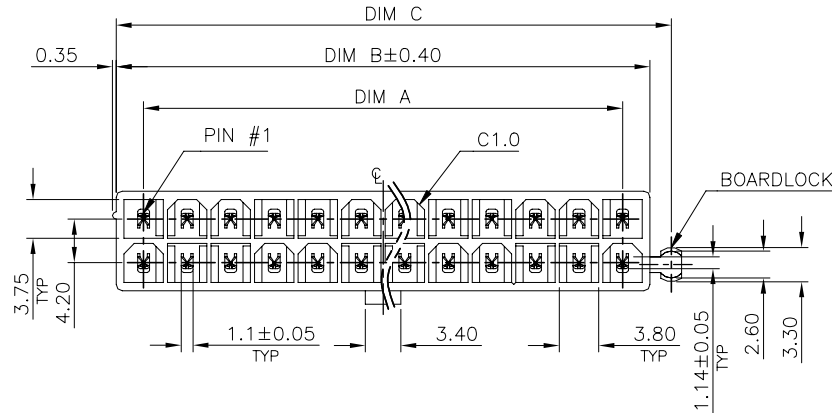

- NOTE:
- MATERIAL:  
HOUSING: PA9T, UL94 V-0, COLOR: (SEE TABLE).  
CONTACTS: BRASS.
  - FINISH:  
CONTACTS: 3.05um [120u"] MIN. MATTE-TIN.  
1.27um [50u"] MIN. NICKEL UNDERPLATED ALL OVER.
  - WAVE SOLDER CAPABLE TO 265°C PER TEST SPEC.  
109-202, CONDITION B.
- ⚠ NO TE LOGO AND DATE CODE ON THE PRODUCT WITH 4 POS.  
5. THE KEY IDENTIFIED WAS SHOWN ON PAGE 5.  
6. PACKING WITH TRAY.

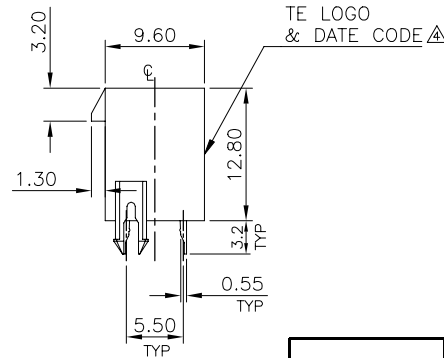
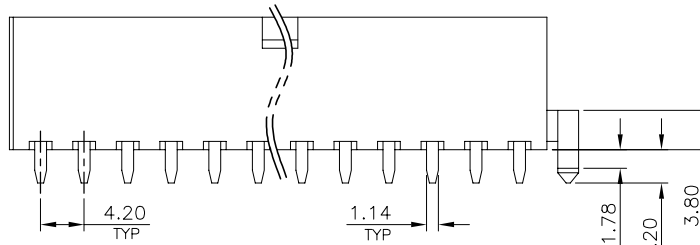

ONE BOARDLOCK (RIGHT)

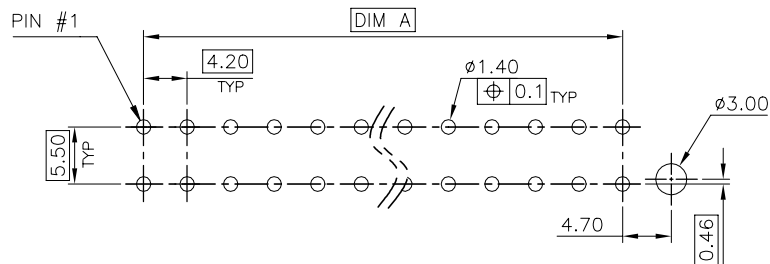

RECOMMENDED PCB LAYOUT  
TOLERANCE: ±0.05 T=1.6mm

IVORY PA9T	5.40	46.2	51.5	53.55	24	3-1775099-8
	4.30	37.8	43.1	45.15	20	3-1775099-7
	3.90	33.6	38.9	40.95	18	3-1775099-6
	3.11	25.2	30.5	32.55	14	3-1775099-5
	2.71	21.0	26.3	28.35	12	3-1775099-4
	2.31	16.8	22.1	24.15	10	3-1775099-3
	1.92	12.6	17.9	19.95	8	3-1775099-2
	1.52	8.4	13.7	15.75	6	3-1775099-1
1.13	4.2	9.5	11.55	4	3-1775099-0	
HSG COLOR & MATERIAL	WEIGHT	DIM A	DIM B	DIM C	POS.	PART NUMBER

THIS DRAWING IS A CONTROLLED DOCUMENT.

DIMENSIONS:  
mm



TOLERANCES UNLESS OTHERWISE SPECIFIED:

0 PLC	± -
1 PLC	± 0.3
2 PLC	± 0.2
3 PLC	± 0.15
4 PLC	± -
ANGLES	± 3°

MATERIAL

FINISH

DWN  
CHK  
APVD  
PRODUCT SPEC  
APPLICATION SPEC  
WEIGHT  
CUSTOMER DRAWING

**STE** TE Connectivity

NAME  
ATX POWER CONNECTOR  
4.2mm PITCH, VERTICAL, DIP TYPE

SIZE	CAGE CODE	DRAWING NO	RESTRICTED TO
A3	00779	C=1775099	

SCALE SHEET 3 OF 7 REV J

THIS DRAWING IS UNPUBLISHED. RELEASED FOR PUBLICATION  
 © COPYRIGHT 2010 BY TYCO ELECTRONICS CORPORATION. ALL RIGHTS RESERVED.

LOC		DIST		REVISIONS			
P	LTR	DESCRIPTION		DATE	DWN	APVD	
DW				SEE SHEET 1.			

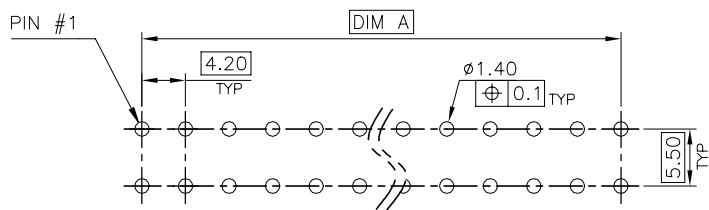
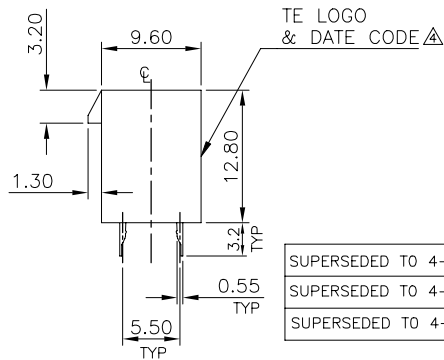
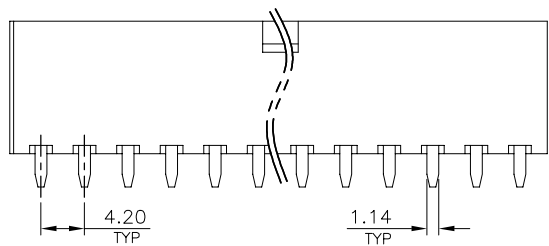
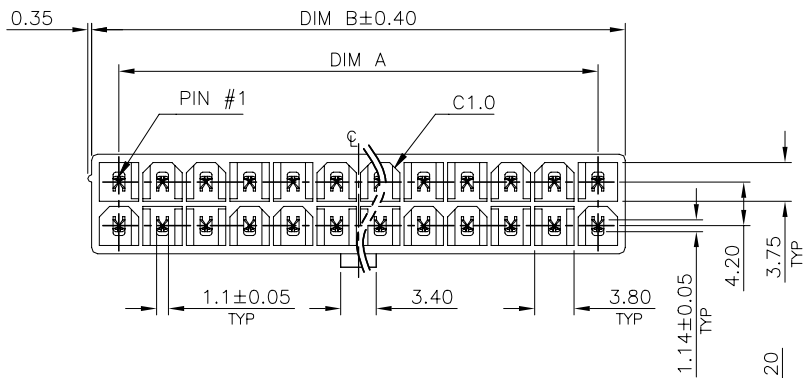

RECOMMENDED PCB LAYOUT  
 TOLERANCE: ±0.05 T=1.6mm

- NOTE:
- MATERIAL:  
 HOUSING: PA9T, UL94 V-0, COLOR: (SEE TABLE).  
 CONTACTS: BRASS.
  - FINISH:  
 CONTACTS: 3.05um [120u"] MIN. MATTE-TIN.  
 1.27um [50u"] MIN. NICKEL UNDERPLATED ALL OVER.
  - WAVE SOLDER CAPABLE TO 265°C PER TEST SPEC.  
 109-202, CONDITION B.
- ⚠ NO TE LOGO AND DATE CODE ON THE PRODUCT WITH 4 POS.  
 5. THE KEY IDENTIFIED WAS SHOWN ON PAGE 5.  
 6. PACKING WITH TRAY.

NO BOARDLOCK

SUPERSEDED TO 4-1775099-3	IVORY PA9T	2.28	16.8	22.1	10	5-1775099-3
SUPERSEDED TO 4-1775099-2		1.89	12.6	17.9	8	5-1775099-2
SUPERSEDED TO 4-1775099-1		1.49	8.4	13.7	6	5-1775099-1
IVORY PA9T	5.37	46.2	51.5	24	4-1775099-8	
	4.27	37.8	43.1	20	4-1775099-7	
	3.87	33.6	38.9	18	4-1775099-6	
	3.08	25.2	30.5	14	4-1775099-5	
	2.68	21.0	26.3	12	4-1775099-4	
	2.28	16.8	22.1	10	4-1775099-3	
	1.89	12.6	17.9	8	4-1775099-2	
	1.49	8.4	13.7	6	4-1775099-1	
	1.10	4.2	9.5	4	4-1775099-0	
	HSG COLOR & MATERIAL	WEIGHT	DIM A	DIM B	POS.	PART NUMBER

THIS DRAWING IS A CONTROLLED DOCUMENT.

DIMENSIONS: mm

TOLERANCES UNLESS OTHERWISE SPECIFIED:

0 PLC	± -
1 PLC	± 0.3
2 PLC	± 0.2
3 PLC	± 0.15
4 PLC	± -
ANGLES	± 3'

MATERIAL: \_\_\_\_\_ FINISH: \_\_\_\_\_

STE TE Connectivity

ATX POWER CONNECTOR  
 4.2mm PITCH, VERTICAL, DIP TYPE

SIZE: A3 CAGE CODE: 00779 DRAWING NO: C=1775099 RESTRICTED TO: \_\_\_\_\_

WEIGHT: SEE TABLE

CUSTOMER DRAWING SCALE: \_\_\_\_\_ SHEET: 4 OF 7 REV: J

THIS DRAWING IS UNPUBLISHED. RELEASED FOR PUBLICATION  
 © COPYRIGHT 2010 BY TYCO ELECTRONICS CORPORATION. ALL RIGHTS RESERVED.

LOC		DIST		REVISIONS			
P	LTR	DESCRIPTION		DATE	DWN	APVD	
DW				SEE SHEET 1.			

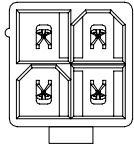

4 POS

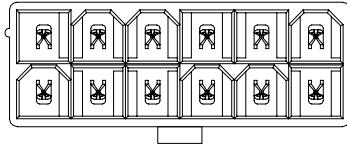

12 POS

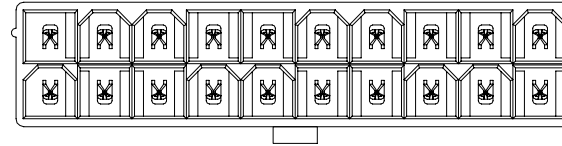

20 POS

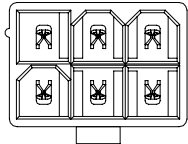

6 POS

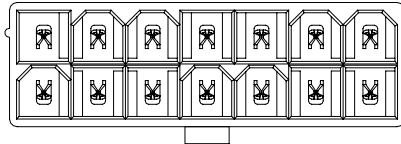

14 POS

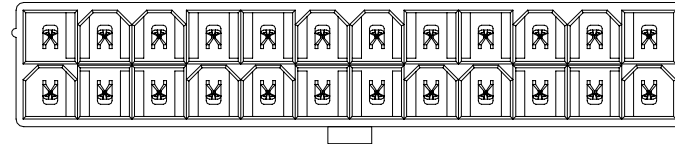

24 POS

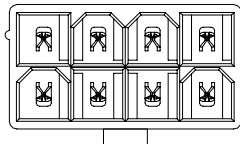

8 POS

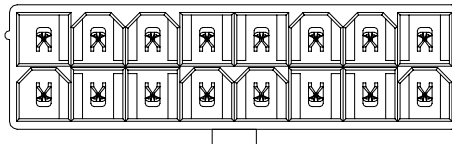

16 POS

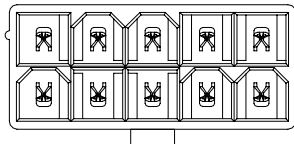

10 POS

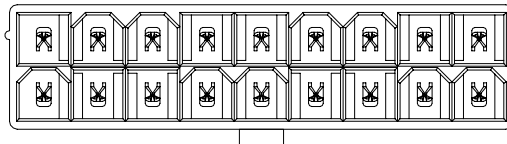

18 POS

KEY POSITION IDENTIFIED  
(TOP VIEW)

THIS DRAWING IS A CONTROLLED DOCUMENT.		DWN _____		TE Connectivity	
DIMENSIONS: mm		CHK _____			
		APVD _____		NAME _____	
TOLERANCES UNLESS OTHERWISE SPECIFIED: 0 PLC ± - 1 PLC ± 0.3 2 PLC ± 0.2 3 PLC ± 0.15 4 PLC ± - ANGLES ± 3°		PRODUCT SPEC _____		ATX POWER CONNECTOR 4.2mm PITCH, VERTICAL, DIP TYPE	
MATERIAL _____		APPLICATION SPEC _____		SIZE A3	RESTRICTED TO _____
FINISH _____		WEIGHT _____		CAGE CODE 00779	DRAWING NO C=1775099
		CUSTOMER DRAWING		SCALE _____	SHEET 5 OF 7
				REV J	

THIS DRAWING IS UNPUBLISHED. RELEASED FOR PUBLICATION  
 © COPYRIGHT 2010 BY TYCO ELECTRONICS CORPORATION. ALL RIGHTS RESERVED.

LOC		DIST		REVISIONS			
P	LTR	DESCRIPTION		DATE	DWN	APVD	
		SEE SHEET 1.					

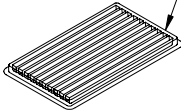
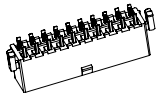
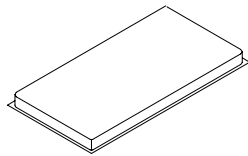

QUANTITY SEE TABLE

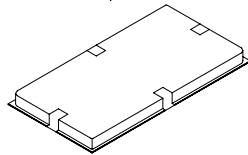

10 TRAY

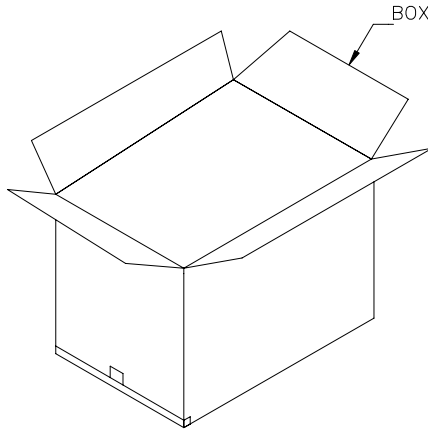
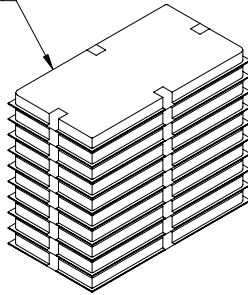

BOX

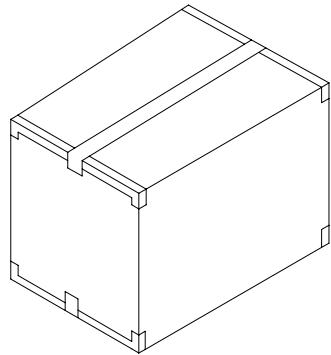

NOTES:

- 1. TRAY : PVC, SIZE: 330mm(L)X 265mm(W)X 22mm(H).
- 2. BOX : CORRUGATED, SIZE: 350mm(L)X 279mm(W)X 195mm(H).
- 3. QUANTITY: SEE TABLE.

GROSS WEIGHT	NET WEIGHT	PCS /TRAY	TRAYS /BOX	PCS /BOX	POS.	NO. OF BOARDLOCK
5.94	4.34	80	10	800	24	2
5.93	4.33	100	10	1000	20	
5.53	3.93	100	10	1000	18	
5.85	4.25	120	10	1200	16	
6.00	4.40	140	10	1400	14	
5.98	4.38	160	10	1600	12	
5.81	4.21	180	10	1800	10	
5.89	4.29	220	10	2200	8	
5.94	4.34	280	10	2800	6	
5.78	4.18	360	10	3600	4	
5.92	4.32	80	10	800	24	1
5.90	4.30	100	10	1000	20	
6.28	4.68	120	10	1200	18	
5.95	4.35	140	10	1400	14	
5.94	4.34	160	10	1600	12	
6.22	4.62	200	10	2000	10	
6.21	4.61	240	10	2400	8	
6.16	4.56	300	10	3000	6	
6.35	4.75	420	10	4200	4	
5.90	4.30	80	10	800	24	
5.87	4.27	100	10	1000	20	
6.24	4.64	120	10	1200	18	
5.91	4.31	140	10	1400	14	
6.42	4.82	180	10	1800	12	
6.16	4.56	200	10	2000	10	
6.51	4.91	260	10	2600	8	
6.67	5.07	340	10	3400	6	
6.88	5.28	480	10	4800	4	

THIS DRAWING IS A CONTROLLED DOCUMENT.

DIMENSIONS: mm		TOLERANCES UNLESS OTHERWISE SPECIFIED:	
	0 PLC ± -	1 PLC ± 0.3	2 PLC ± 0.2
	3 PLC ± 0.15	4 PLC ± -	ANGLES ± 3'
MATERIAL	FINISH		

DWN	-
CHK	-
APVD	-
PRODUCT SPEC	-
APPLICATION SPEC	-
WEIGHT	-
CUSTOMER DRAWING	-

**STE** TE Connectivity

ATX POWER CONNECTOR  
4.2mm PITCH, VERTICAL, DIP TYPE

SIZE	CAGE CODE	DRAWING NO	RESTRICTED TO
A3	00779	C=1775099	

SCALE: - SHEET: 6 OF 7 REV: J

THIS DRAWING IS UNPUBLISHED. RELEASED FOR PUBLICATION  
 © COPYRIGHT 2010 BY TYCO ELECTRONICS CORPORATION. ALL RIGHTS RESERVED.

LOC	DIST	REVISIONS			
P	LTR	DESCRIPTION	DATE	DWN	APVD
DW		SEE SHEET 1.			

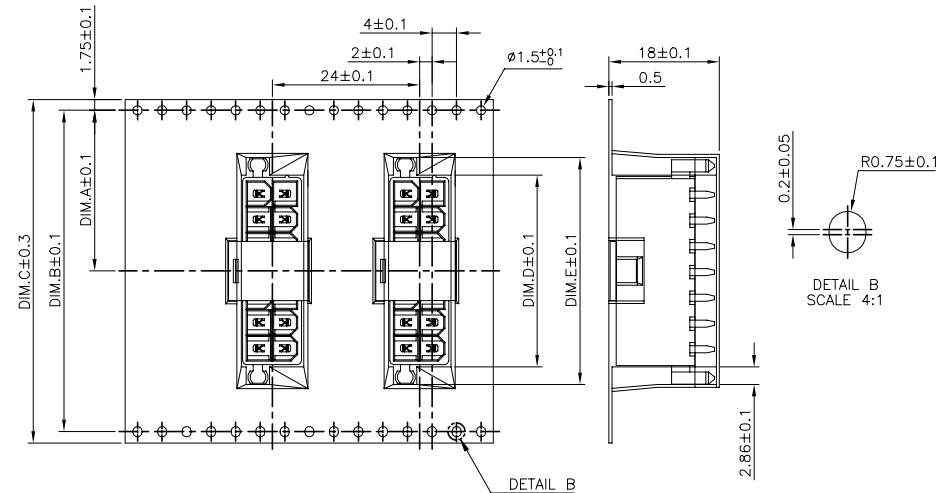
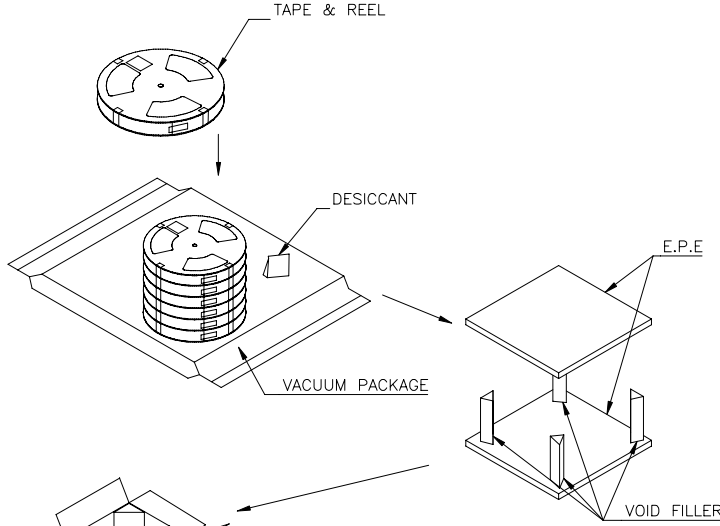
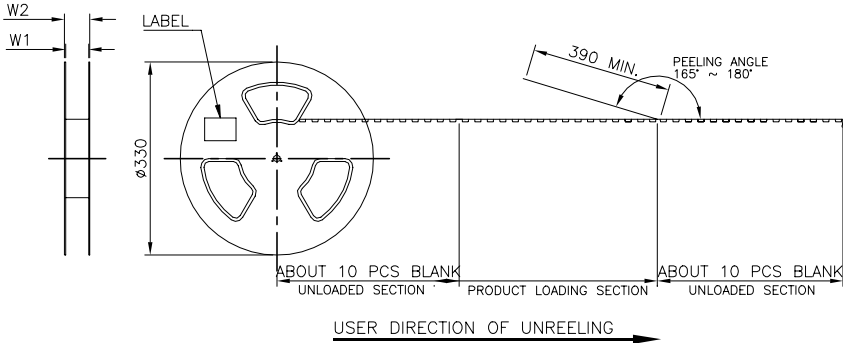

- NOTES:
- MATERIAL:  
 BOX: FIBREBOARD, CORRUGATED, DOUBLE WALL.  
 COVER TAPE: PET, TRANSPARENT COLOR.  
 CARRIER TAPE: POLYSTYRENES, BLACK COLOR.  
 REEL: POLYSTYRENES, BLUE COLOR.  
 BAG: POLYETHYLENE.
  - PEELING STRENGTH: 0.1 ~ 1.3 N (10 ~ 130 GRAMS)
  - PEELING SPEED: 300 mm/min.
  - EACH BAG SHALL BE INCLUDED DESICCANT.

60.4	56.4	37.0	31.28	56.0	52.4	26.2	5.7 KG	2.40 KG	140	5	700	14	6-1775099-9
W2	W1	DIM. E	DIM. D	DIM. C	DIM. B	DIM. A	GROSS WEIGHT	NET WEIGHT	PCS/ REEL	REEL/ BOX	PCS/ BOX	POS.	PART NUMBER

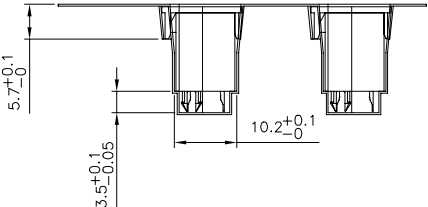

THIS DRAWING IS A CONTROLLED DOCUMENT.

DIMENSIONS: mm	TOLERANCES UNLESS OTHERWISE SPECIFIED: 0 PLC ± - 1 PLC ± 0.3 2 PLC ± 0.2 3 PLC ± 0.15 4 PLC ± - ANGLES ± 3'	DWN	CHK	APVD	NAME
MATERIAL	FINISH	PRODUCT SPEC	APPLICATION SPEC	WEIGHT	SIZE
		CUSTOMER DRAWING		A3 00779 C=1775099	
		SCALE		SHEET 7 OF 7	
				REV J	

**STE** TE Connectivity  
 ATX POWER CONNECTOR  
 4.2mm PITCH, VERTICAL, DIP TYPE

## X-ON Electronics

Largest Supplier of Electrical and Electronic Components

*Click to view similar products for [Power to the Board](#) category:*

*Click to view products by [TE Connectivity](#) manufacturer:*

Other Similar products are found below :

[6450171-4](#) [6450552-7](#) [6600323-8](#) [6643429-1](#) [6646040-2](#) [6651939-1](#) [6766604-1](#) [120959-1](#) [1393557-2](#) [1393532-2](#) [1393532-3](#) [1393532-4](#)  
[1393557-1](#) [1600812-5](#) [1-6450861-2](#) [1744132-7](#) [1761122-1](#) [1766250-1](#) [1892109-1](#) [2-6450860-5](#) [2-6450870-0](#) [1-6450161-4](#) [1-6450850-6](#) [1-](#)  
[6450869-6](#) [1645526-2](#) [1-6600130-0](#) [2005243-2](#) [377-0020-11130](#) [TE34-12-16P-F0](#) [51700-10201602AALF](#) [5-6450830-6](#) [5646956-4](#) [377-](#)  
[0080-11131A](#) [4-6450830-9](#) [4-6600333-3](#) [10125416-4050LF](#) [10130248-005LF](#) [6600320-3](#) [3-6450860-5](#) [1888123-2](#) [6450166-1](#) [6643978-1](#)  
[6766605-1](#) [701-15-02109](#) [N11444](#) [6651938-1](#) [6450810-7](#) [46437-1112](#) [1-1589677-8](#) [5646956-5](#)