

1. PART NUMBER 1-1924067-9 SHOWN ON DRAWING.
2. TPA AND CPA (WHEN APPLICABLE) ARE SHIPPED IN THEIR PRE-LATCHED POSITIONS. SEE INSTRUCTION SHEET 408-8968 FOR DIRECTIONS ON MOVING THE CPA AND TPA TO THE PRE-LATCHED POSITION, IF NECESSARY.
3. TERMINALS SOLD SEPARATELY. FOR USE WITH TE MCON 1.2mm CLEAN BODY CONTACT WITH WIRE SEAL. SEE TE MCON 1.2-CB (CLEAN BODY) TABLE FOR APPLICABLE PART NUMBERS.
4. APPLICABLE HEADER INTERFACE DRAWING 114-18679-3 IS AVAILABLE UPON REQUEST. A COPY OF THIS DRAWING CAN BE OBTAINED FROM THE TYCO ELECTRONICS PRODUCT MANAGER, VIA YOUR TE CONNECTIVITY SALES REPRESENTATIVE OR CUSTOMER SERVICE.
5. MINIMUM FEED THROUGH CONDITION WITH 1.0mm CLEARANCE ALL AROUND.
6. TRACEABILITY PRINTED IN THIS LOCATION AT ASSEMBLY.
7. NOTE LEFT BLANK INTENTIONALLY.
8. PART NUMBERS 1924067-7, -8, 1-7, 1-8 INNER HOUSING ARE ASSEMBLED 180°.
9. PROTOTYPE ASSEMBLIES USE GERMAN OUTER HOUSING P/N: 1718648-1, CPA P/N: 1670193-1 AND SEAL P/N: 1718650-1.
10. NOTE DELETED
11. TPA ENGAGE FORCE: PRESET TO FULL ≥ 2 N AND ≤ 60 N.
12. TPA DISENGAGE FORCE: DISENGAGE FROM FULL TO PRESET ≥ 2 N AND ≤ 60 N.
13. CPA ENGAGE FORCE: PRESET TO FULL WITHOUT CONNECTORS MATED ≥ 40 N.
14. CPA ENGAGE FORCE: PRESET TO FULL WITH CONNECTORS MATED < 30 N.
15. POLARIZATION FEATURE EFFECTIVENESS:
CONNECTOR MATED TURNED 180° NO MATING > 125 N.
WRONG KEYING NO MATING > 125 N.
16. VALIDATED UP TO USCAR TEMPERATURE CLASS III.
17. SEE INSTRUCTION SHEET 408-8928.
18. REFERENCE SHEET 2 FOR ISOMETRIC VIEWS.
19. TERMINAL 1670146-x REPLACES 1418847-x
20. ACTUAL BASE MATERIAL IS PA66 GF13%. THIS MATERIAL HAS A TOLERANCE OF $\pm 2\%$ BY FORMULATION. MARKING SHOWN ON DRAWING IS BASED ON MAX GLASS FILL (GF) % ALLOWED BY THE FORMULATION. NA MANUFACTURING REGION WILL IMPRINT THE MAX GLASS FILLED ALLOWANCE. THE CHINA MANUFACTURING REGION WILL IMPRINT THE NOMINAL GLASS FILLED ALLOWANCE.
21. DUE TO VARIATION IN MOLD DESIGN, SOME NON-FUNCTIONAL FEATURES OF THE ASSEMBLY MAY VARY FROM WHAT IS SHOWN ON THE DRAWING. FORM, FIT, FUNCTION ARE NOT IMPACTED.

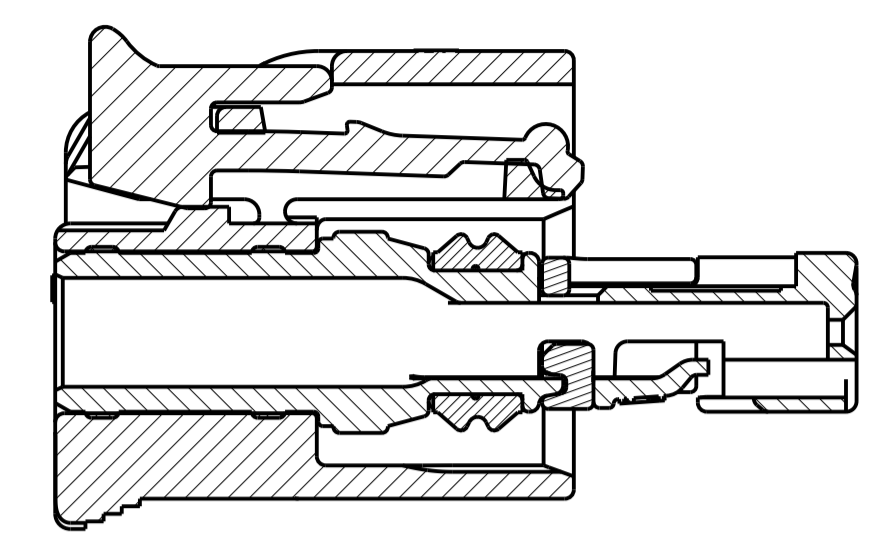

SECTION B-B
SHOWN WITH CPA (WHEN APPLICABLE)
IN IT'S LATCHED POSITION
FOR REFERENCE ONLY

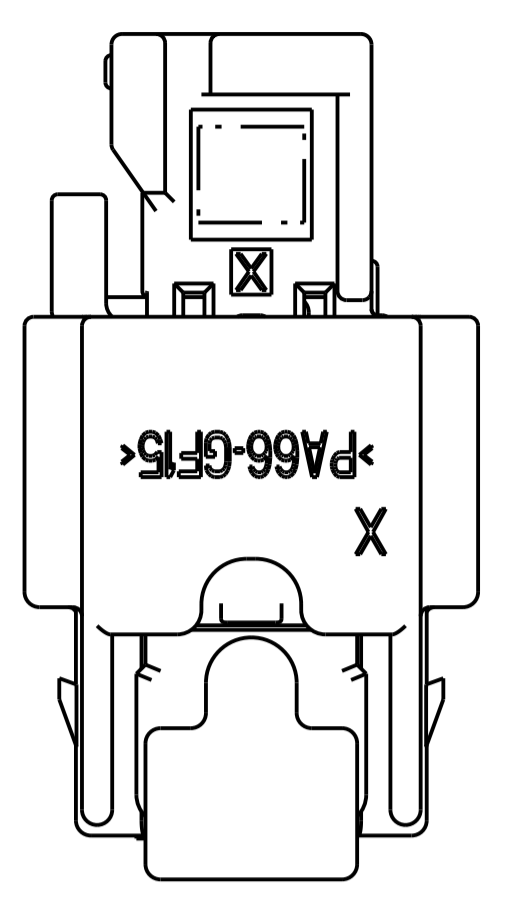
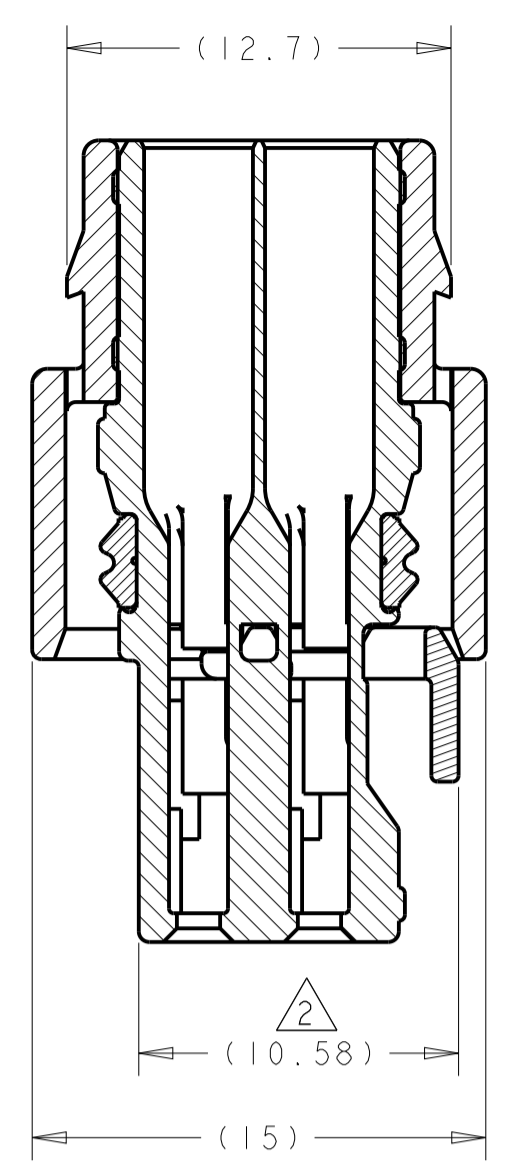

SECTION A-A

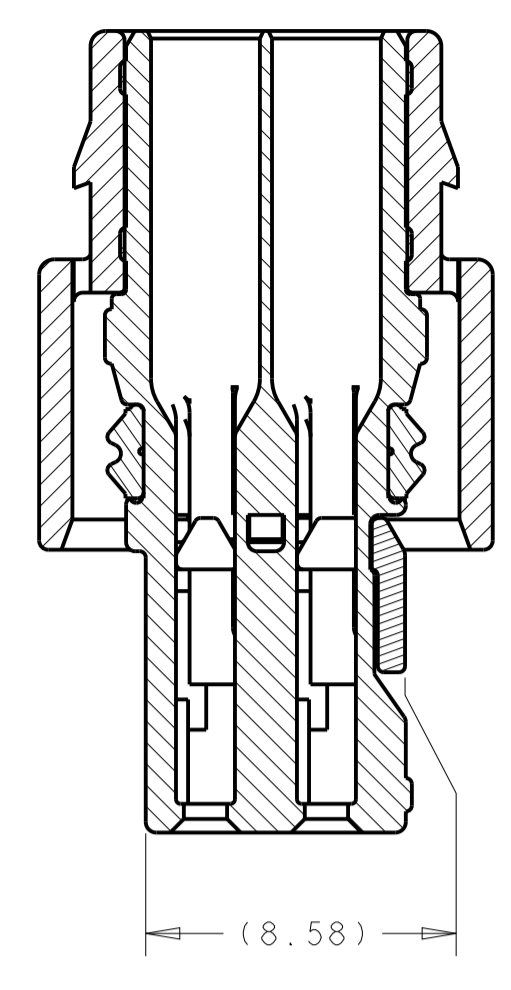

SECTION A-A
SHOWN WITH TPA
IN IT'S LATCHED POSITION
FOR REFERENCE ONLY

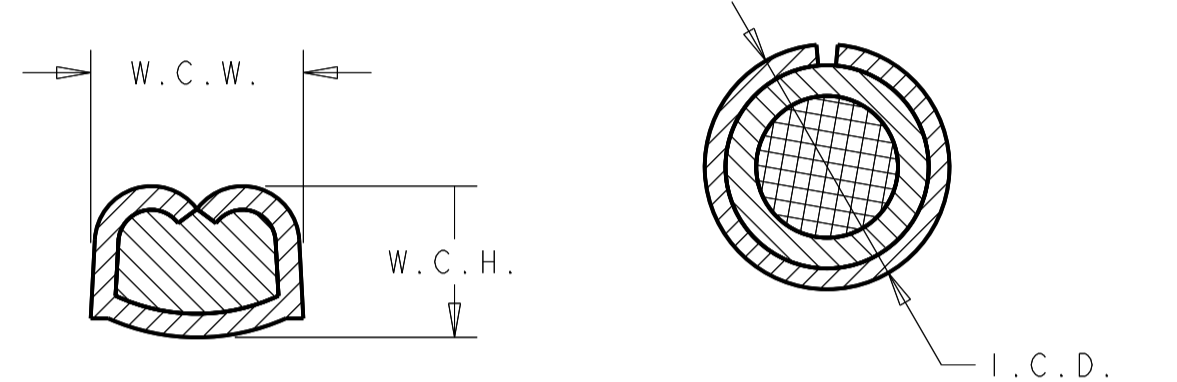
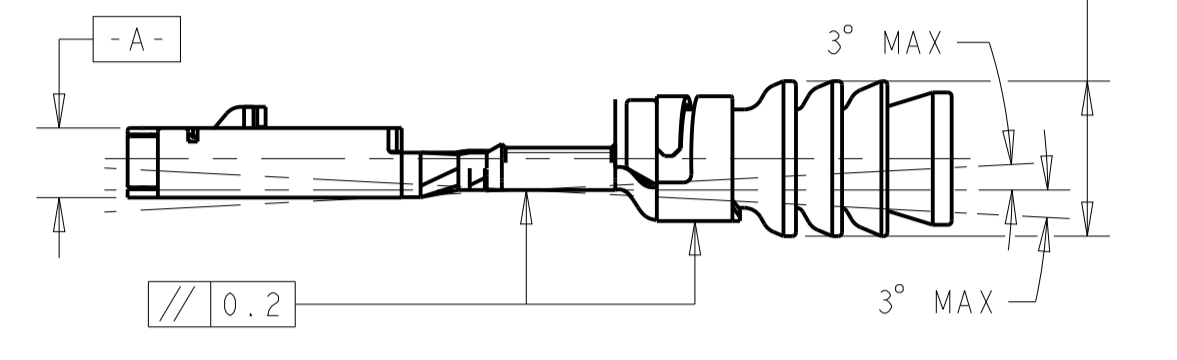
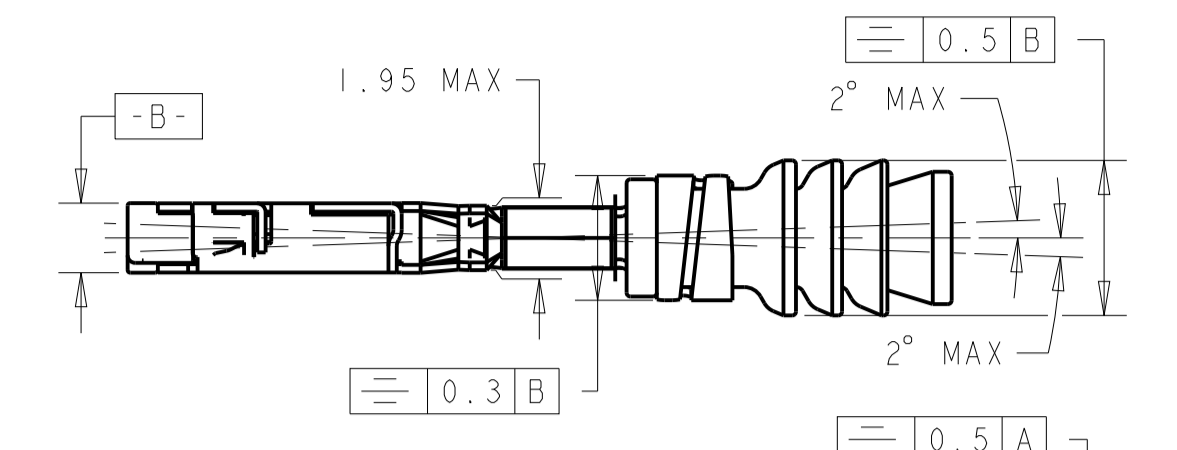

WIRE CRIMP
DIMENSIONS

INSULATION CRIMP
DIMENSIONS

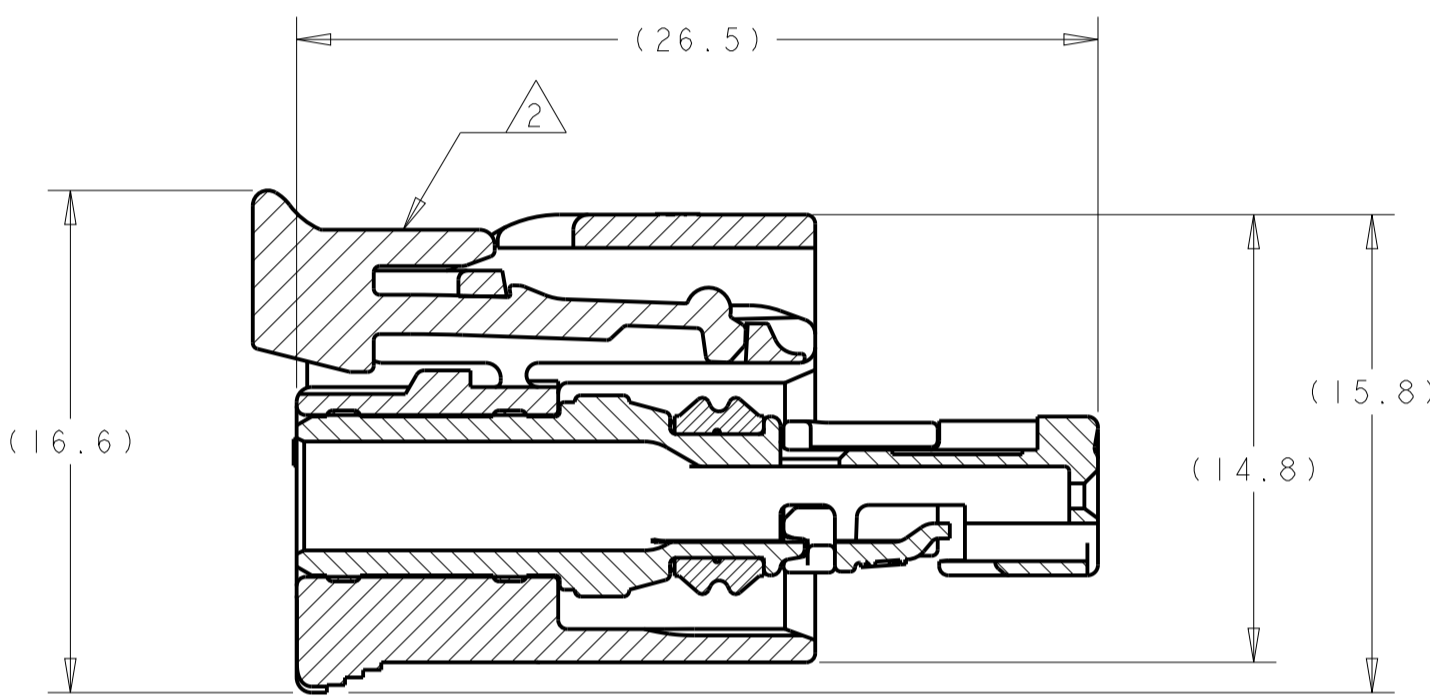

SECTION B-B

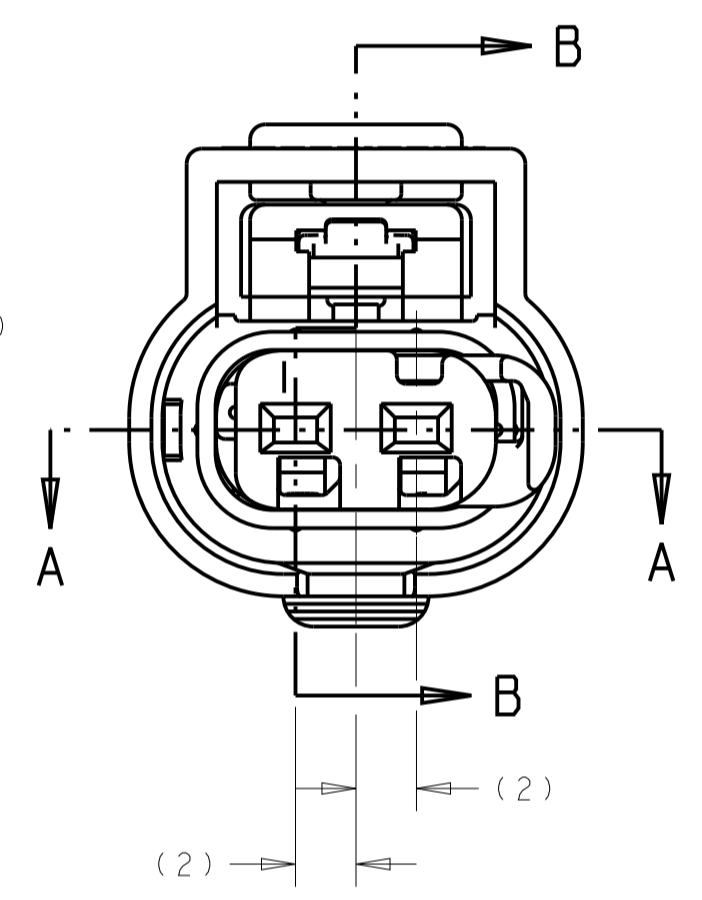

KEYING CONFIGURATIONS

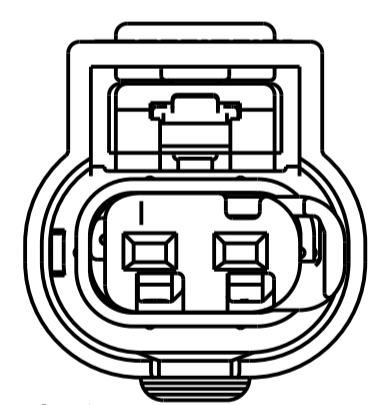

SCALE 3:1
KEYING OPTION A

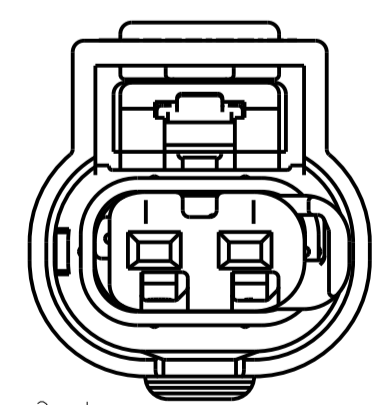

SCALE 3:1
KEYING OPTION B

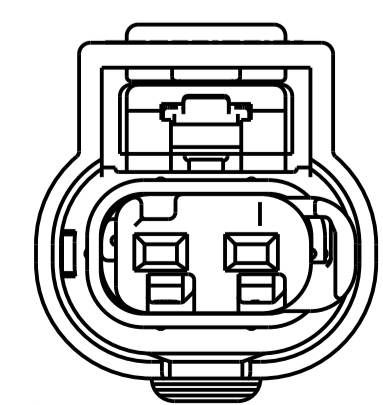

SCALE 3:1
KEYING OPTION C

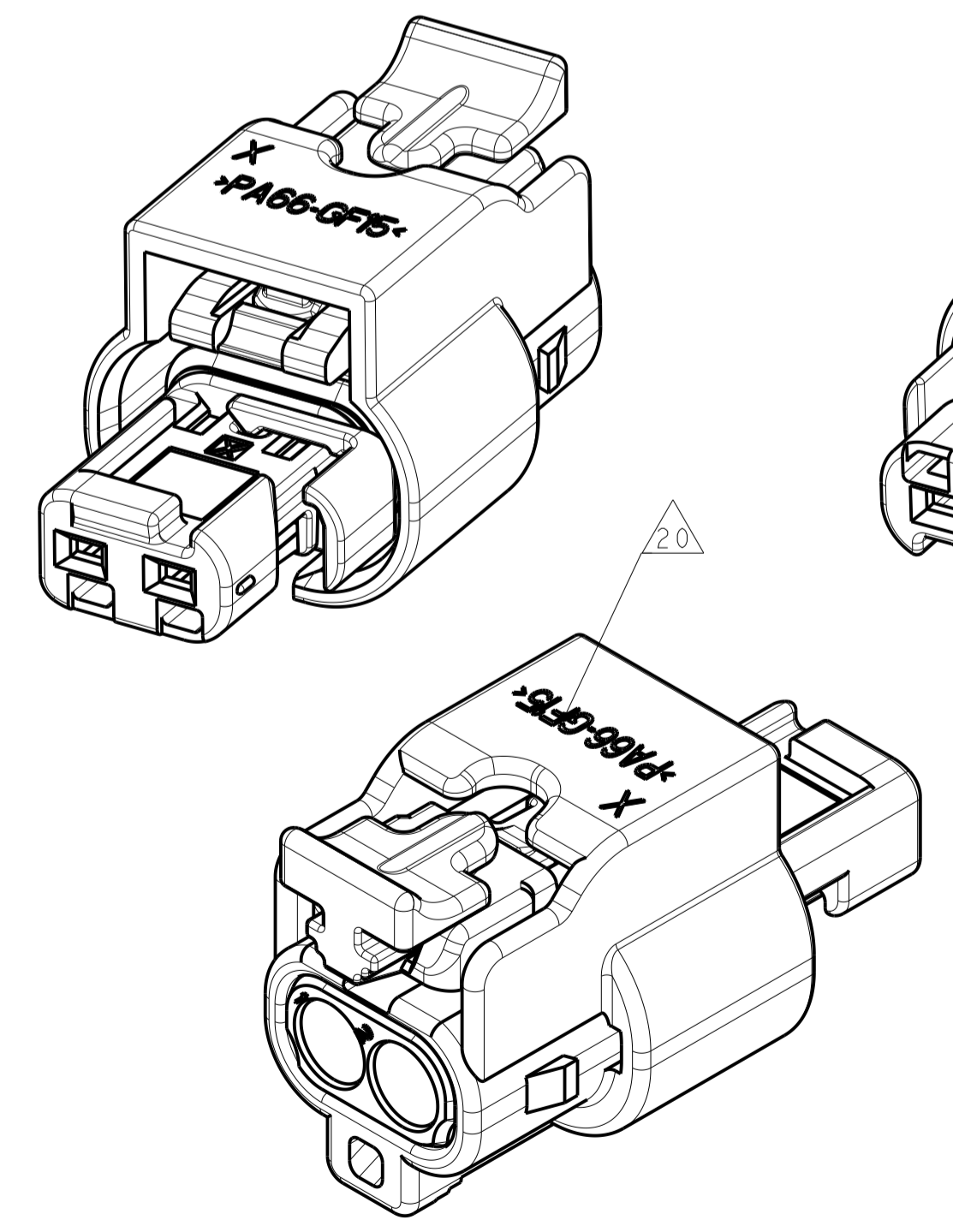

NORTH AMERICA MANUFACTURING REGION

ISOMETRIC VIEWS
1-1924067-9

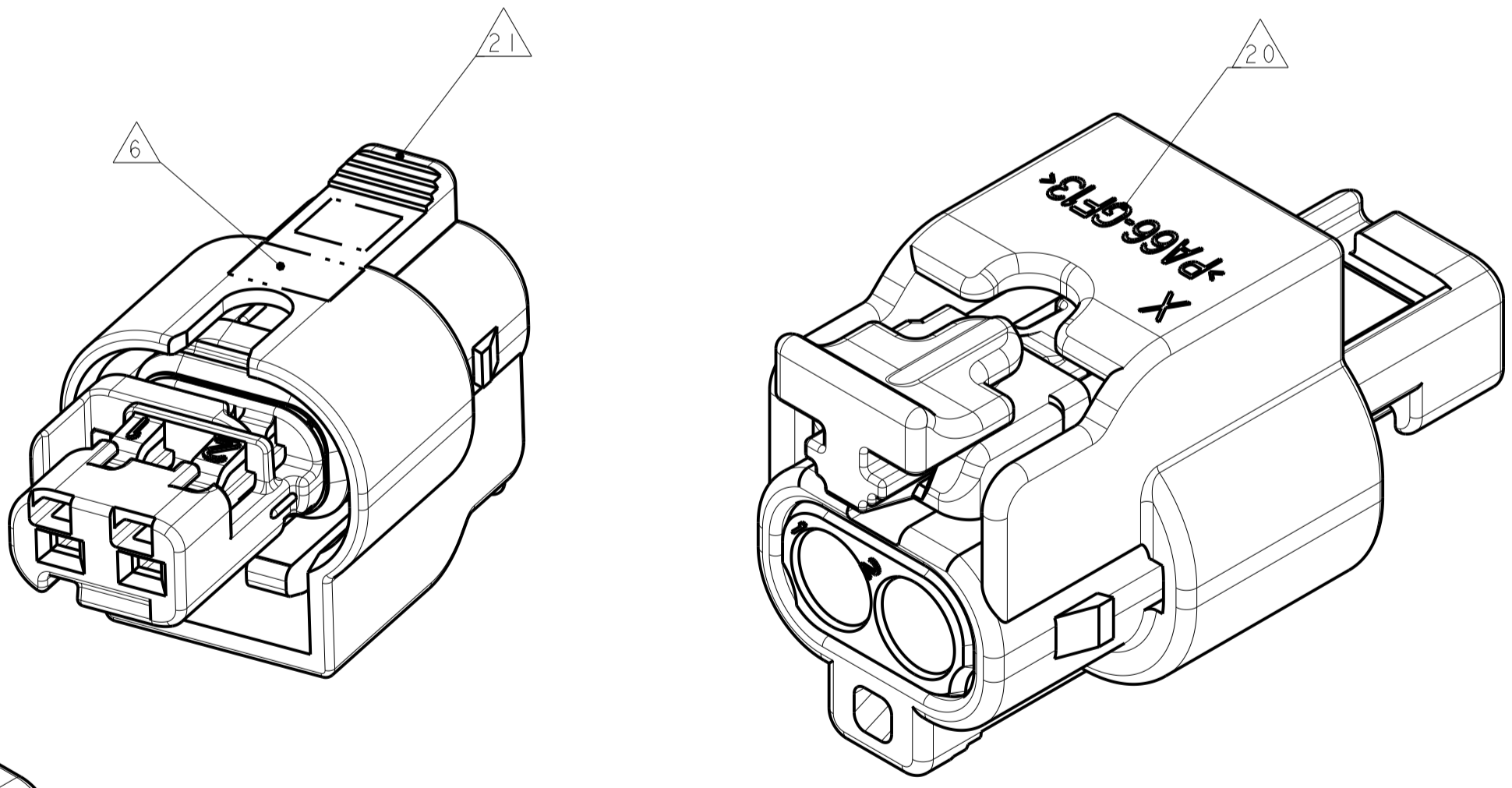

CHINA MANUFACTURING REGION
ISOMETRIC VIEWS
1-1924067-9

TE MCON 1.2-CB (CLEAN BODY)								
PART NUMBER	PLATING	WIRE STRIP LENGTH	AWG	INSL. RANGE	W.C.H.	W.C.W.	I.C.D.	WIRE SEAL PART NUMBER
1418844-3	SILVER			1.2 TO 1.4	0.86 ± 0.03	1.27 ± 0.05	3.15 ± 0.05	967067-2
1418844-2	GOLD	3.3 ± 0.3	22					
1418844-1	TIN							
1670146-3	SILVER			1.4 TO 1.9	0.84 ± 0.03	1.57 ± 0.05	3.25 ± 0.05	967067-1
1670146-2	GOLD	3.6 ± 0.3	20					
1670146-1	TIN							
1418850-3	SILVER			1.8 TO 2.4	1.11 ± 0.05	1.31 ± 0.05		
1418850-2	GOLD	3.6 ± 0.3	18		1.11 ± 0.05	1.78 ± 0.05	3.35 ± 0.05	964972-1
1418850-1	TIN				1.31 ± 0.05			

RELEASED	RED	2138907-1	BLUE	C	4-1924067-3
RELEASED	RED	2138907-1	NATURAL	B	4-1924067-2
RELEASED	RED	2138907-1	BLACK	A	4-1924067-1
RELEASED	VIOLET	1989913-2	BLUE	C	2-1924067-1
RELEASED	VIOLET	1989913-2	NATURAL	B	2-1924067-0
RELEASED	VIOLET	1989913-2	BLACK	A	1-1924067-9
RELEASED	RED	1488787-1	BLACK	A	1-1924067-8
RELEASED	-	-	BLACK	A	1-1924067-7
RELEASED	RED	1488787-1	BLUE	C	1-1924067-6
RELEASED	RED	1488787-1	NATURAL	B	1-1924067-5
RELEASED	RED	1488787-1	BLACK	A	1-1924067-4
RELEASED	-	-	BLUE	C	1-1924067-3
RELEASED	-	-	NATURAL	B	1-1924067-2
RELEASED	-	-	BLACK	A	1-1924067-1

STATUS	COLOR	PART NO	COLOR	KEY	PART NUMBER
9 OBSOLETE					1924067-8
9 OBSOLETE					1924067-7
9 OBSOLETE					1924067-6
9 OBSOLETE					1924067-5
9 OBSOLETE					1924067-4
9 OBSOLETE					1924067-3
9 OBSOLETE					1924067-2
9 OBSOLETE					1924067-1

THIS DRAWING IS A CONTROLLED DOCUMENT.

TE CONNECTIVITY

CONNECTOR ASSEMBLY, FEMALE, 2 POSITION SEALED, 1.2mm STANDARD LATCH VERSION

SCALE 4:1 SHEET 1 OF 2 REV B9

REVISIONS				
P.	LTN	DESCRIPTION	DATE	APVD
-	-	SEE SHEET 1	-	-

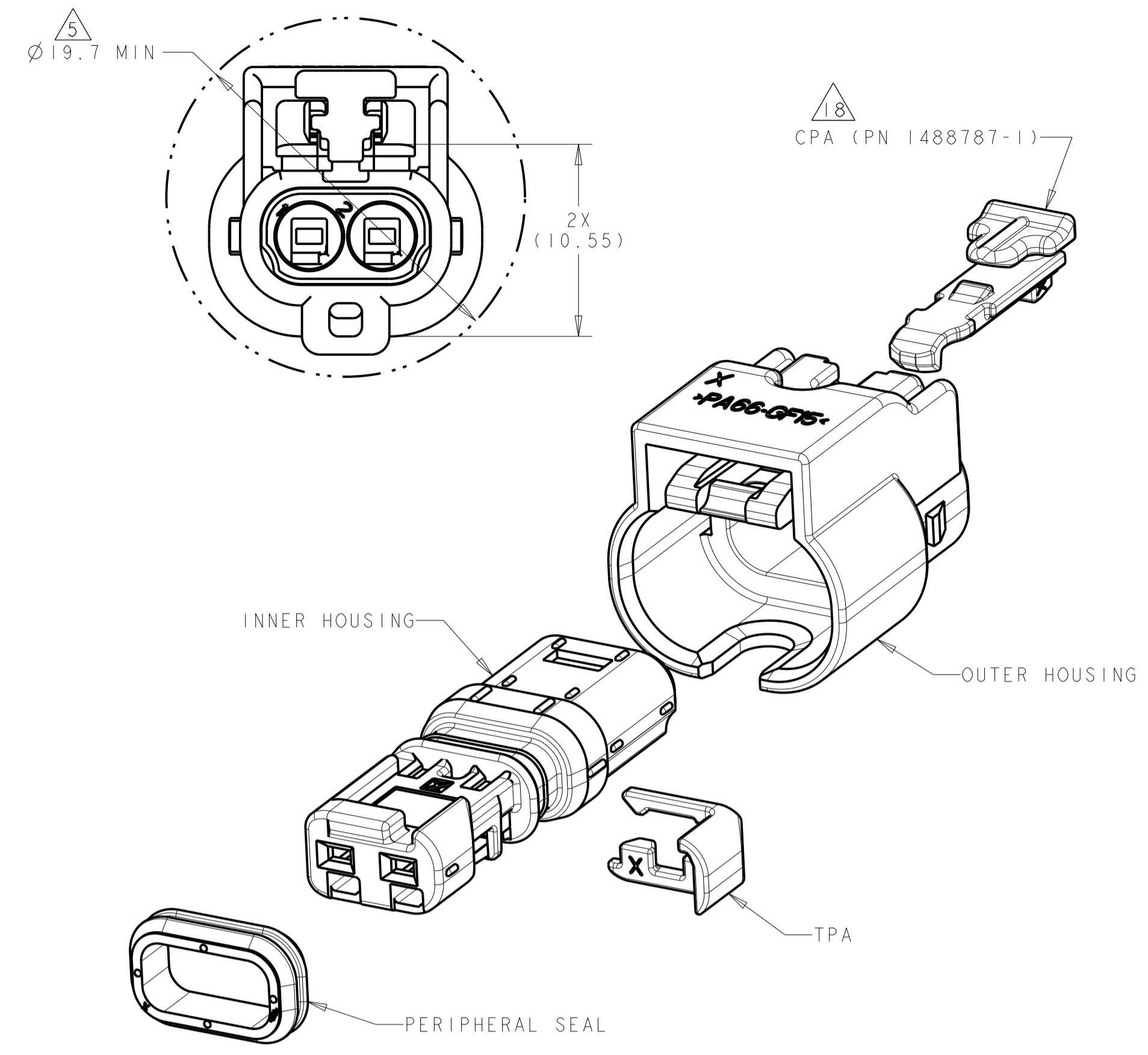

1-1924067-4
EXPLODED ISOMETRIC VIEW

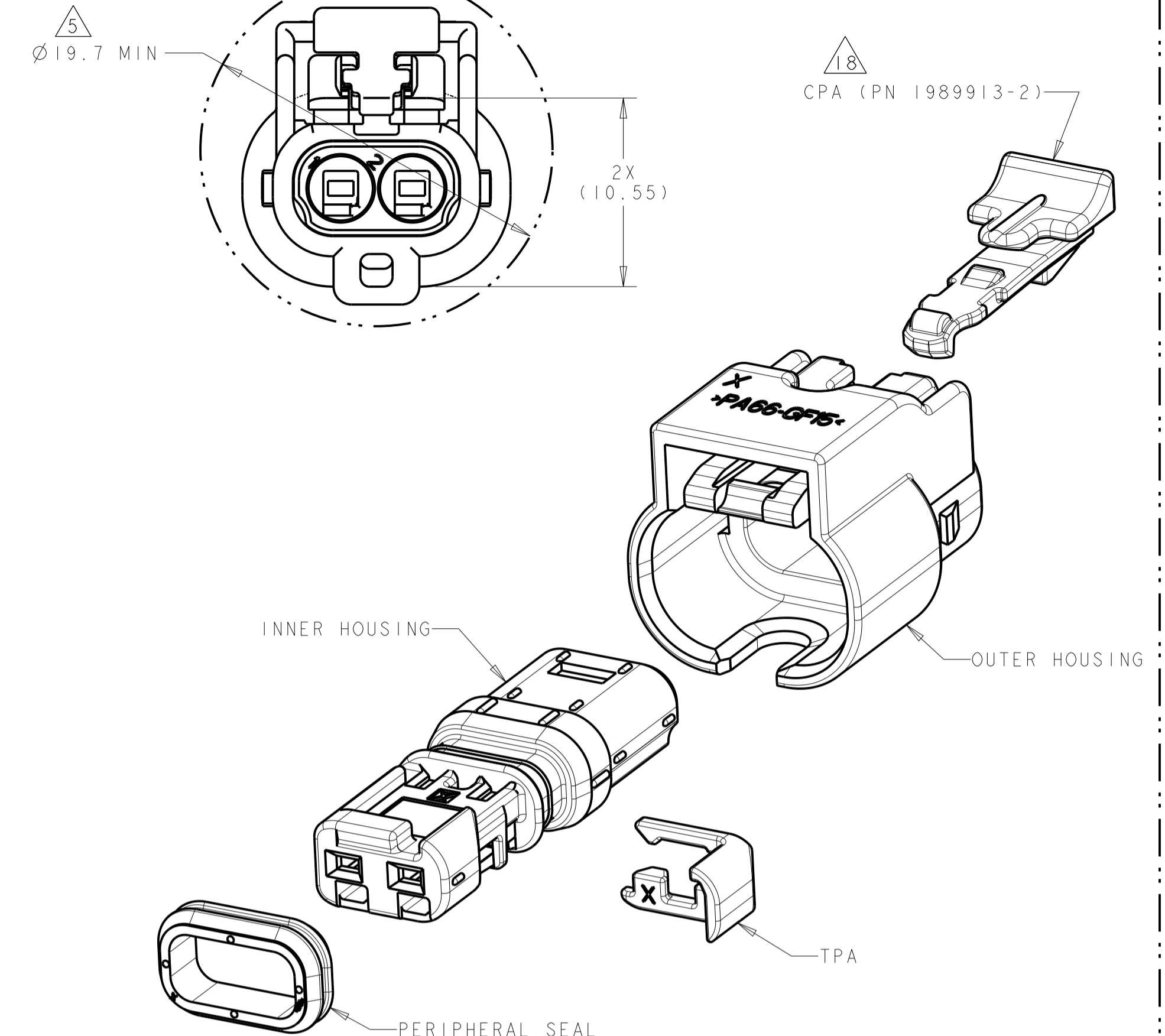

1-1924067-9
EXPLODED ISOMETRIC VIEW

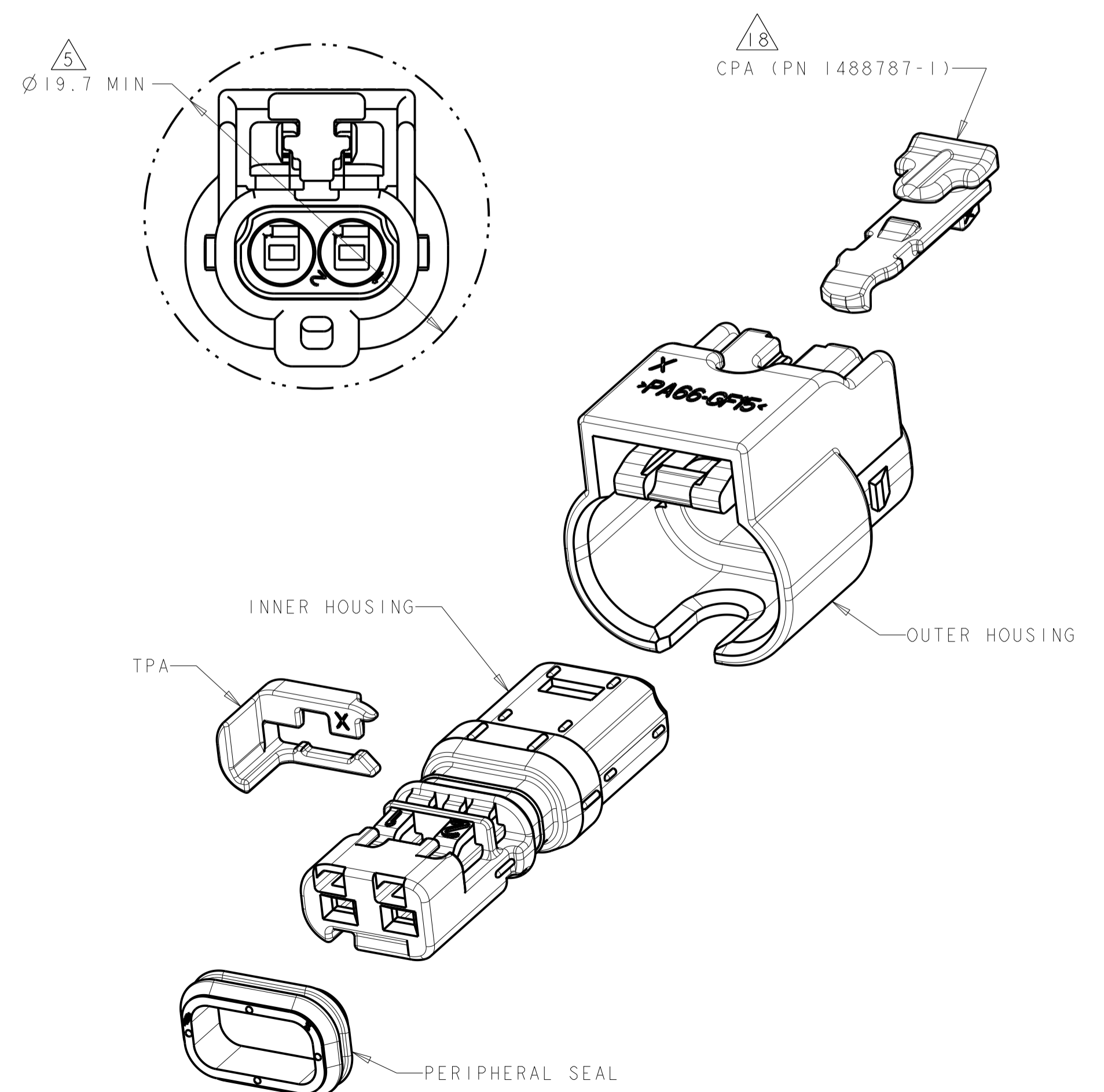

1-1924067-8
EXPLODED ISOMETRIC VIEW

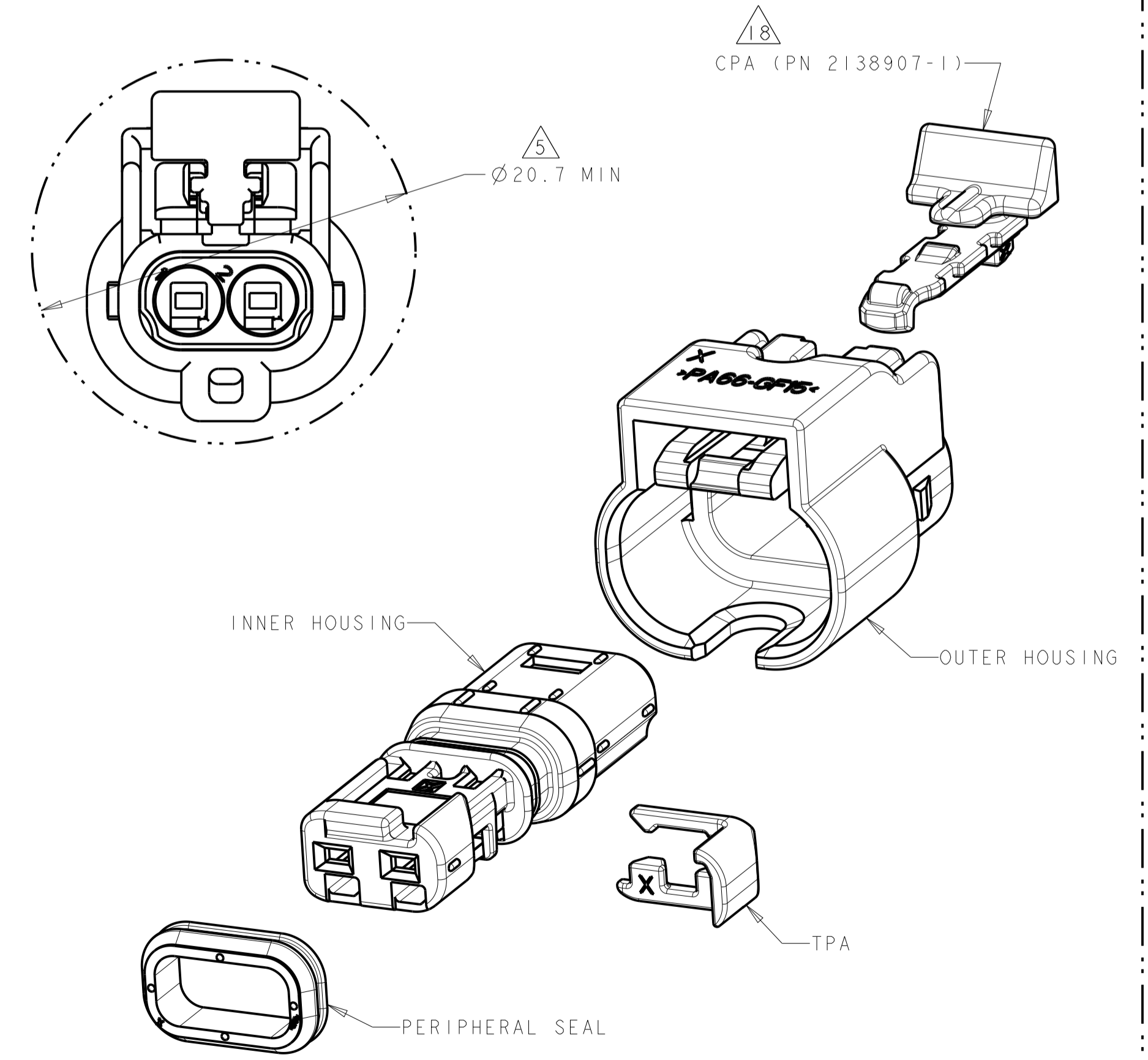

4-1924067-1
EXPLODED ISOMETRIC VIEW

THIS DRAWING IS A CONTROLLED DOCUMENT.		OWN: M. FORISKA 25SEP2006	TE TE Connectivity
DIMENSIONS: mm		CHK: G. MARTIN 25SEP2006	
TOLERANCES UNLESS OTHERWISE SPECIFIED:		APVD: G. MARTIN 25SEP2006	NAME: CONNECTOR ASSEMBLY, FEMALE, 2 POSITION SEALED, 1.2mm STANDARD LATCH VERSION
0 PLC	±	PRODUCT SPEC	
1 PLC	±0.3	APPLICATION SPEC	SIZE: CAGE CODE DRAWING NO
2 PLC	±0.10	RESTRICTED TO	A100779C=1924067
3 PLC	±	WEIGHT: 2.07g	SCALE: 4:1
4 PLC	±	CUSTOMER DRAWING	SHEET 2 OF 2
ANGLES	±1°		REV: B9
SEE TABLE			

X-ON Electronics

Largest Supplier of Electrical and Electronic Components

Click to view similar products for [Automotive Connectors](#) category:

Click to view products by [TE Connectivity](#) manufacturer:

Other Similar products are found below :

[003-018-000](#) [60403001](#) [60993906-B](#) [M902-2131](#) [M902-2161](#) [72.330.1035.1](#) [73.353.4028.0](#) [F119300-B](#) [F166900](#) [F258300-B](#) [F358300-B](#)
[F407400](#) [F444110](#) [F487000](#) [F509500B-B](#) [827153-1](#) [8N1515-32-24P](#) [9-1326729-8](#) [925474-1](#) [928905-1](#) [964562-4](#) [968782-1](#) [GT17SA-8DS-](#)
[HU](#) [98891-1012](#) [98947-1016](#) [12004147](#) [12004475-L](#) [12010290](#) [12010309-B](#) [12015454](#) [12020219-B](#) [12020308](#) [12041318-B](#) [12052225-L](#)
[12052466](#) [12059125](#) [12064869](#) [12004327-B](#) [12010503-B](#) [12015308](#) [12015384](#) [12015909](#) [1-21030-1](#) [12041254](#) [12041318](#) [12047946-B](#)
[12047957](#) [12047957-L](#) [12059473](#) [12066261](#)