

THIS DRAWING IS UNPUBLISHED. RELEASED FOR PUBLICATION
 © COPYRIGHT 19 BY AMP INCORPORATED. ALL INTERNATIONAL RIGHTS RESERVED.

LOC		DIST		P		F		ZONE		LTR		REVISIONS		
CH		11										DESCRIPTION	DATE	APPD
										D		ECN96022902 OBSOLETE (PENDING) 192447-3	05/MAR/96	
										D1		REVISED PER ECO-09-020935	09SEP09	AEG

- ① FINISH - SILVER PLATE, 200 MIN μ INCHES THICK, PER AMP SPEC 112-32-1.
- ② FINISH - NICKEL PLATE, 100 MIN μ INCHES THICK, PER AMP SPEC 112-246-1.
- ③ HARDWARE FURNISHED FOR:
 - 192447-7 2 NUTS, 2 WASHERS
 - 1-192447-1 2 NUTS, NO WASHERS
 - 1-192447-9 1 NUT, NO WASHERS
- ④ UNLESS OTHERWISE SPECIFIED, ϕ "F" EQUALS ϕ "C".
- ⑤ OBSOLETE PARTS: OBSOLETE CIS STREAMLINING PER D.RENAUD/D.SINISI

⑤	OBSOLETE	-	-	9.4[.37]	ϕ 6.1[.24]	1/2-20UNF-2A	31.7[1.25]	NO	A	1	-	2-192447-0						
		-	-	17.0[.67]	ϕ 8.2[.32]	9/16-18UNF-2A	34.2[1.35]	YES	A	1	-	1-192477-9						
		-	-	17.0[.67]	ϕ 8.2[.32]	9/16-18UNF-2A	34.2[1.35]	NO	A	1	09112	1-192447-8						
		-	-	9.4[.37]	ϕ 4.1[.16]	5/16-32UNEF-2A	19.6[.77]	NO	A	1	-	1-192447-7						
		-	41.8[1.64]	19.9[.78]	ϕ 35.0[1.38]	M50 X 1.5-6g	62.0[2.44]	NO	B	1	09133	1-192447-6						
		-	41.3[1.62]	20.7[.81]	ϕ 30.0[1.18]	M48 X 1.5-6g	62.0[2.44]	NO	B	1	09079	1-192447-5						
	OBSOLETE	-	43.1[1.69]	21.9[.86]	ϕ 25.0[.98]	1 5/8-16UN-2A	62.2[2.45]	NO	B	1	09165	1-192447-4						
		-	-	21.1[.83]	ϕ 20.1[.79]	1 1/4-18UNEF-2A	42.2[1.66]	NO	A	1	09173	1-192447-3						
		-	-	17.3[.68]	ϕ 12.0[.47]	3/4-16UNF-2A	34.0[1.34]	NO	A	1	10260	1-192447-2						
⑤	OBSOLETE	-	-	17.0[.67]	ϕ 8.2[.32]	9/16-18UNF-2A	34.2[1.35]	YES	A	1	-	1-192447-1						
		-	-	8.4[.33]	ϕ 2.3[.09]	5/16-32UNEF-2A	16.5[.65]	NO	A	1	09183	1-192447-0						
		-	-	9.4[.37]	ϕ 4.1[.16]	M8 X 0.75-6g	19.6[.77]	NO	A	1	09026	192447-9						
		-	-	9.4[.37]	ϕ 4.1[.16]	5/16-32UNEF-2A	19.6[.77]	NO	A	1	09111	192447-8						
		-	-	9.4[.37]	ϕ 4.1[.16]	5/16-32UNEF-2A	19.6[.77]	YES	A	2	10244	192447-7						
		-	-	14.5[.57]	ϕ 4.1[.16]	5/16-32UNEF-2A	28.4[1.12]	NO	A	1	10394	192447-6						
		ϕ 4.3[.17]	-	14.5[.57]	ϕ 4.1[.16]	5/16-32UNEF-2A	38.1[1.50]	NO	A	1	10611	192447-5						
		-	-	9.4[.37]	ϕ 6.1[.24]	1/2-28UNEF-2A	19.6[.77]	NO	A	1	10934	192447-4						
		-	-	9.4[.37]	ϕ 6.1[.24]	1/2-20UNF-2A	19.6[.77]	NO	A	2	10263	192447-3						
		-	-	9.4[.37]	ϕ 6.1[.24]	1/2-20UNF-2A	19.6[.77]	NO	A	1	09182	192447-2						
⑤	OBSOLETE	-	-	19.2[.76]	ϕ 16.1[.63]	15/16-20UNEF-2A	38.1[1.50]	NO	A	1	09066	192447-1						
		F	E	D	C	B	A	H'WARE INCL	FIGURE	FINISH (NOTE #)	WAS	PART NO.						

DO NOT SCALE PRINT. UNLESS SPECIFIED DIMENSIONS IN mm [INCHES] TOLERANCES ON : 1 PLC DEC \pm 0.5 [.02] 2 PLC DEC \pm 0.25 [.010] ANGLES \pm -	DR D. WILSON 04-02-92 CHK R.JAYNE 5-04-92 APPD A.GRIFFIN 5-04-92 APPD P.GLASER 5-06-92	AMP AMP Incorporated Harrisburg, PA 17105-3608	
MATERIAL BRASS	PRODUCT SPEC -	NAME THREADED SLEEVE SOCKET ASSY	
FINISH ① ②	APPLICATION SPEC -	SIZE C	CAGE CODE 00779
	WEIGHT -	SCALE NONE	DRAWING NO 192447
			SHEET 1 OF 2

LOC		DIST		ZONE		LTR		REVISIONS		DATE	APPD
CH	11	P	F					DESCRIPTION		05-12-93	
									SEE SHEET 1		

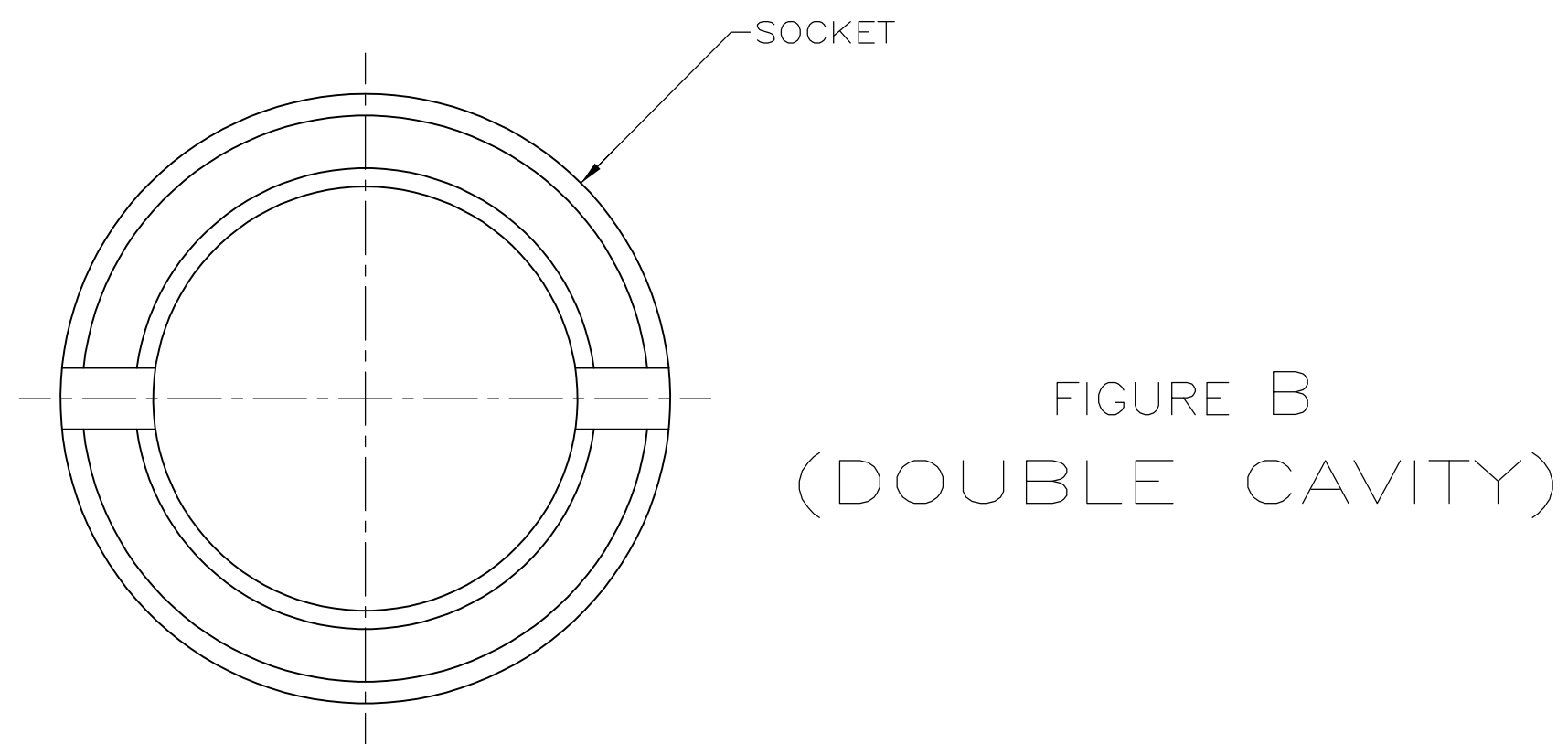
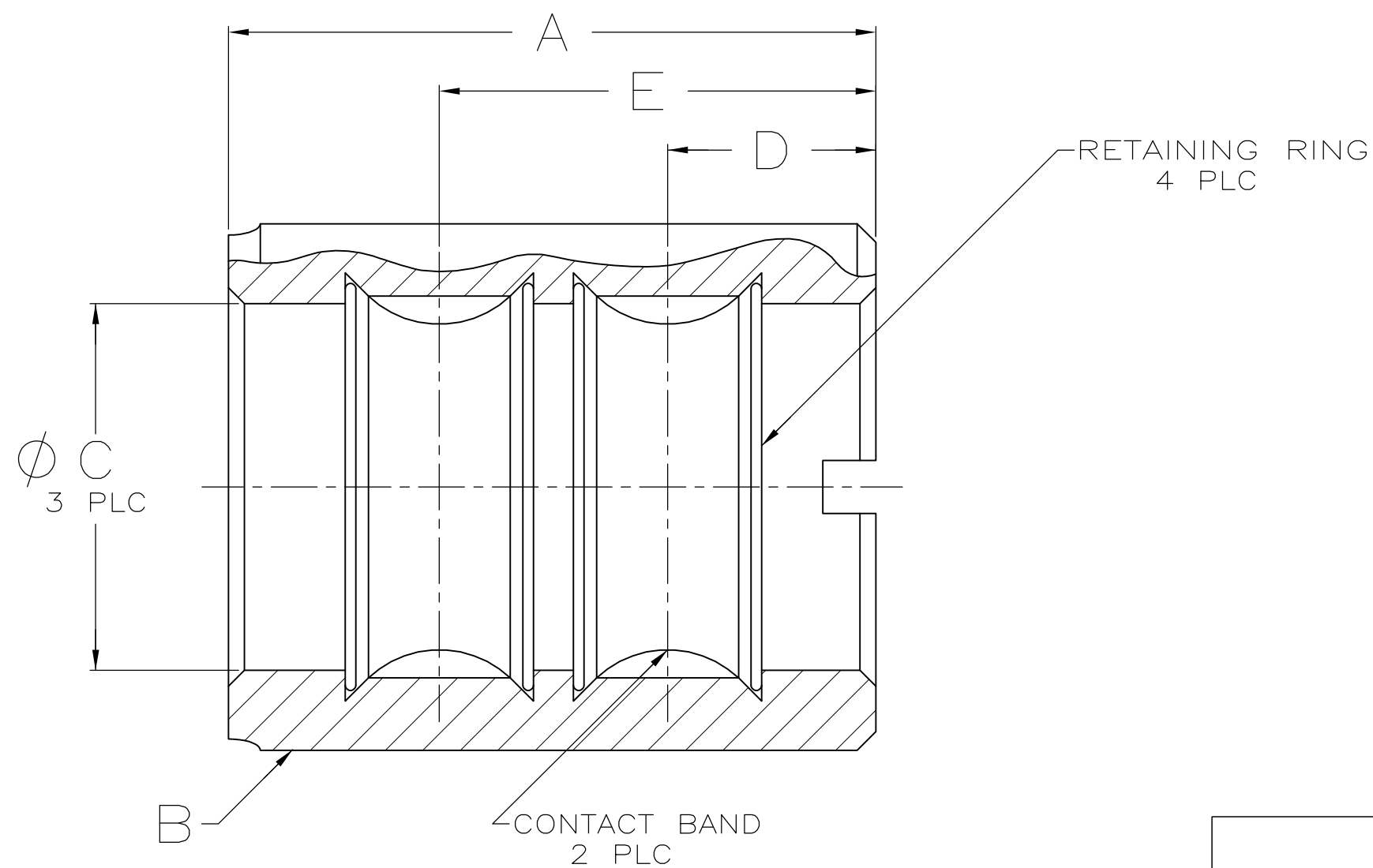
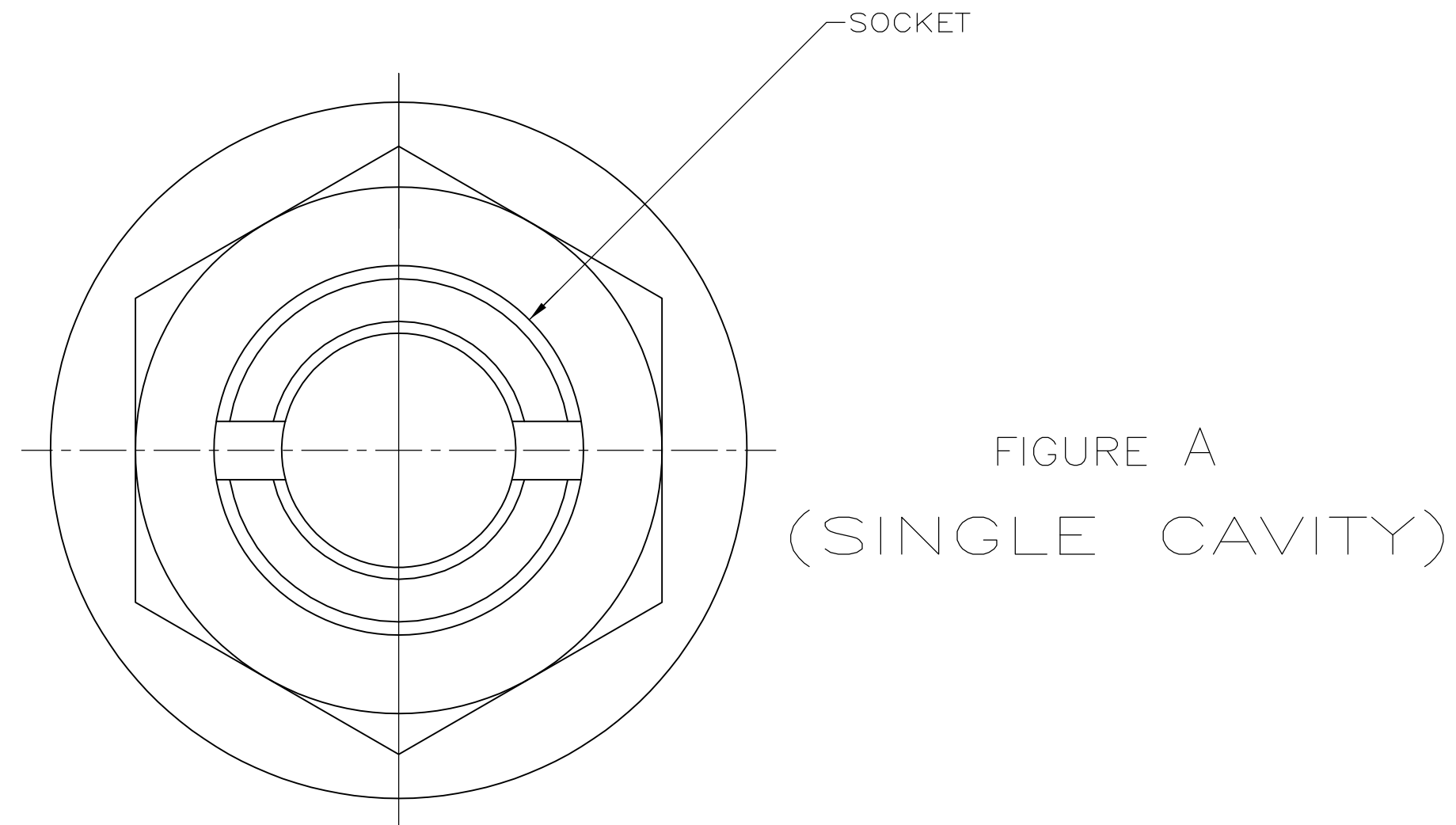
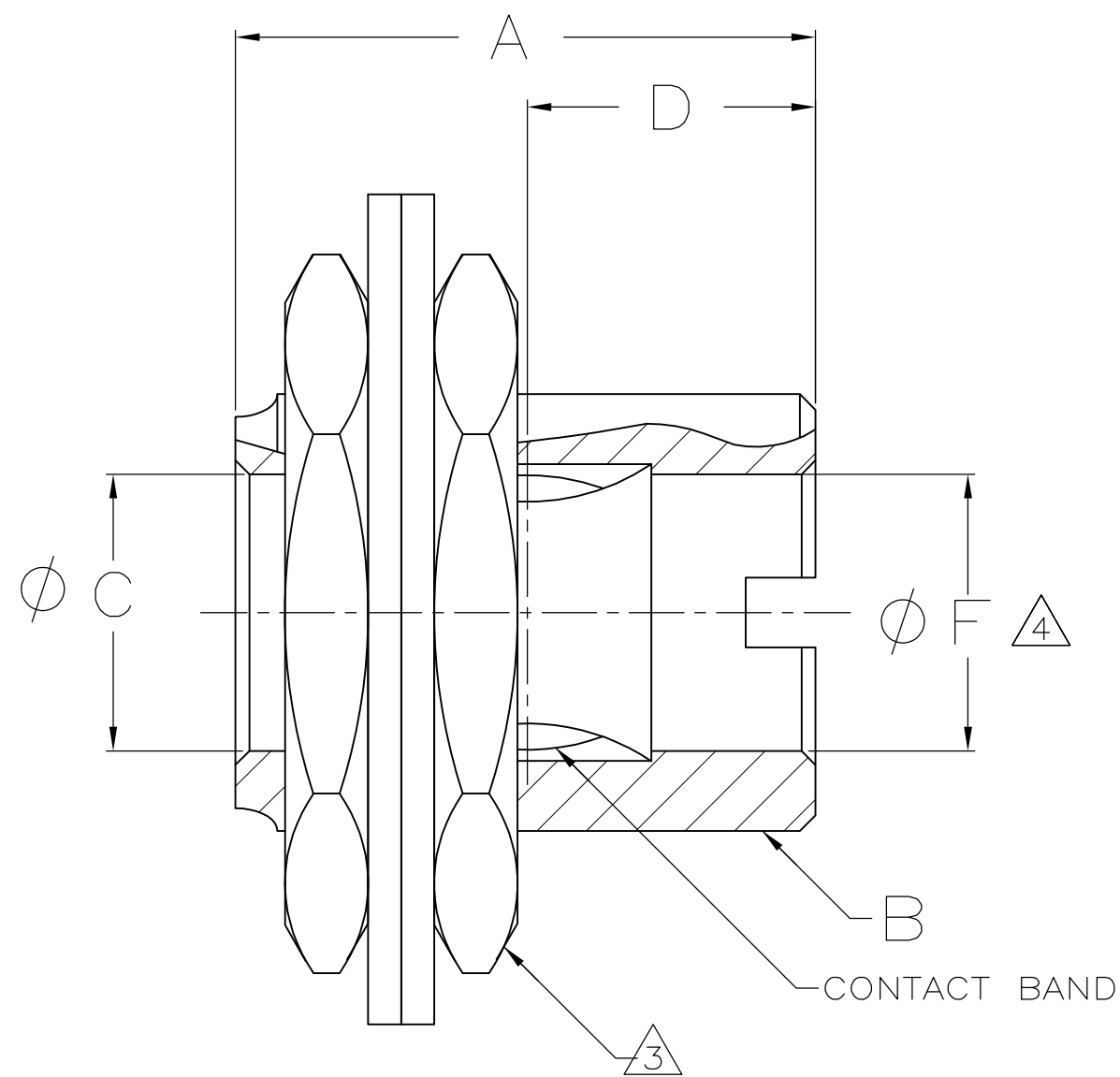

DO NOT SCALE PRINT. UNLESS SPECIFIED DIMENSIONS IN mm [INCHES] TOLERANCES ON : 1 PLC DEC ± 0.5 [.02] 2 PLC DEC ± 0.25 [.010] ANGLES ± -	DR D. WILSON 04-02-92	 AMP Incorporated Harrisburg, PA 17105-3608	
	CHK R.JAYNE 5-04-92		
MATERIAL	APPD A.GRIFFIN 5-04-92	NAME	
	APPD P.GLASER 5-06-92	THREADED SLEEVE SOCKET ASSY	
FINISH	APPLICATION SPEC	SIZE	CAGE CODE
		C	00779
	WEIGHT	SCALE	DRAWING NO
		NONE	192447
			SHEET
			2 OF 2

X-ON Electronics

Largest Supplier of Electrical and Electronic Components

Click to view similar products for [Heavy Duty Power Connectors](#) category:

Click to view products by [TE Connectivity](#) manufacturer:

Other Similar products are found below :

[1424439](#) [1424438](#) [09330062652](#) [605601-1](#) [6340G1](#) [6341G1](#) [6360G1](#) [6373G1](#) [6374g2](#) [6396G1](#) [647757-1](#) [6643411-1](#) [6646058-2](#) [6646137-1](#)
[6646138-1](#) [6646348-1](#) [6646479-1](#) [6646608-1](#) [6646786-1](#) [6646940-1](#) [6651525-1](#) [6651529-1](#) [6651778-1](#) [6651788-1](#) [696465-1](#) [696475-1](#)
[73000005059](#) [73000005349](#) [73000005642](#) [73080965046](#) [765-15-0080A](#) [765-16-0080B](#) [789.700-44](#) [789.700-54](#) [80-1010](#) [80-9](#) [827381-1](#)
[829992-1](#) [902-77-02113](#) [PL00U-301-10D10](#) [PM103MOOLOO](#) [PM212MOOLOO](#) [PM309FOOLOO](#) [PM324FOOLCH](#) [PMHPAF11S03](#)
[PMHPAF14S01](#) [PMHPAM14P05](#) [PMHPAS06](#) [PMHPBF14S01](#) [PP45PC12S](#)