

| REVISIONS | | | | | |
|-----------|-----|---------------------------|-----------|-----|------|
| P | LTR | DESCRIPTION | DATE | DWN | APVD |
| N | | REVISED PER ECO-16-004940 | 29JUL2016 | NK | MZ |
| P | | REVISED PER ECO-18-000441 | 24JAN2018 | RS | MZ |
| R | | REVISED PER ECO-20-002045 | 13FEB2020 | RK | MZ |

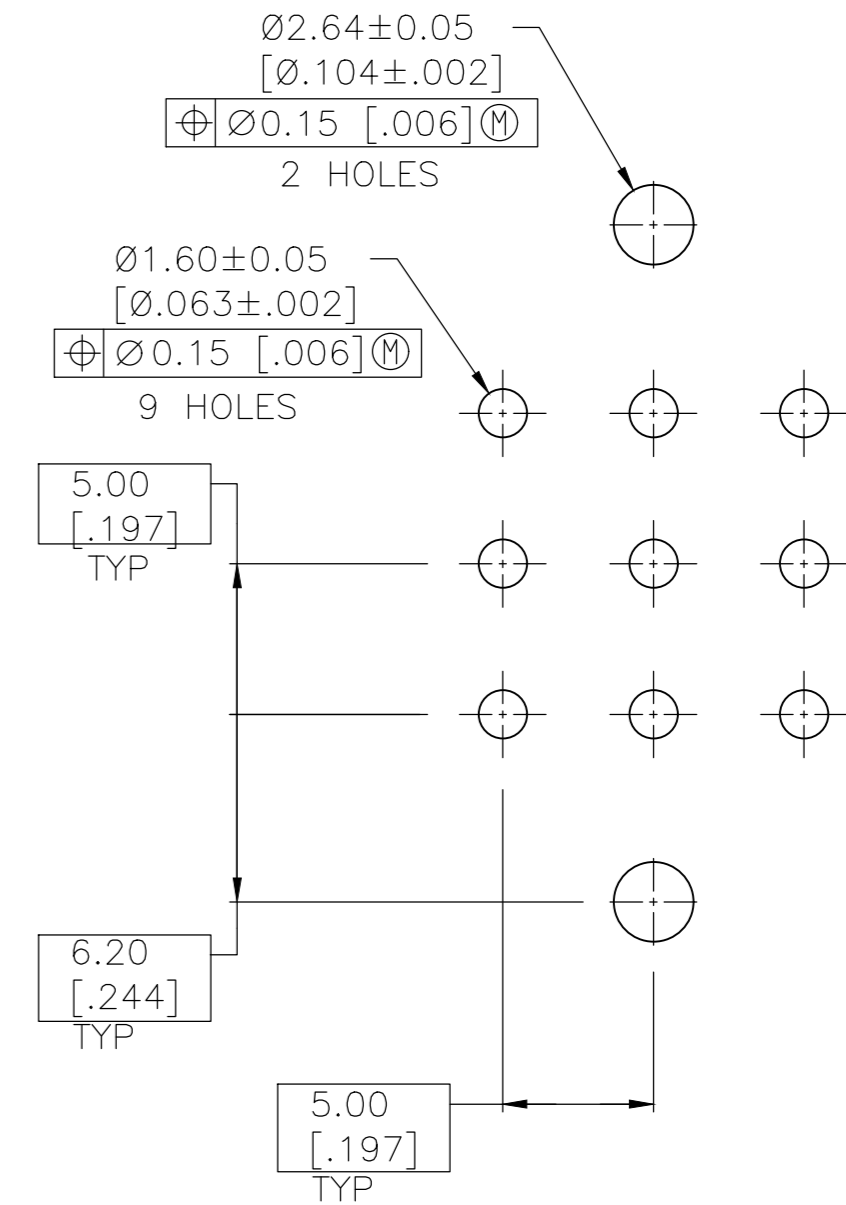

RECOMMENDED PC BOARD LAYOUT

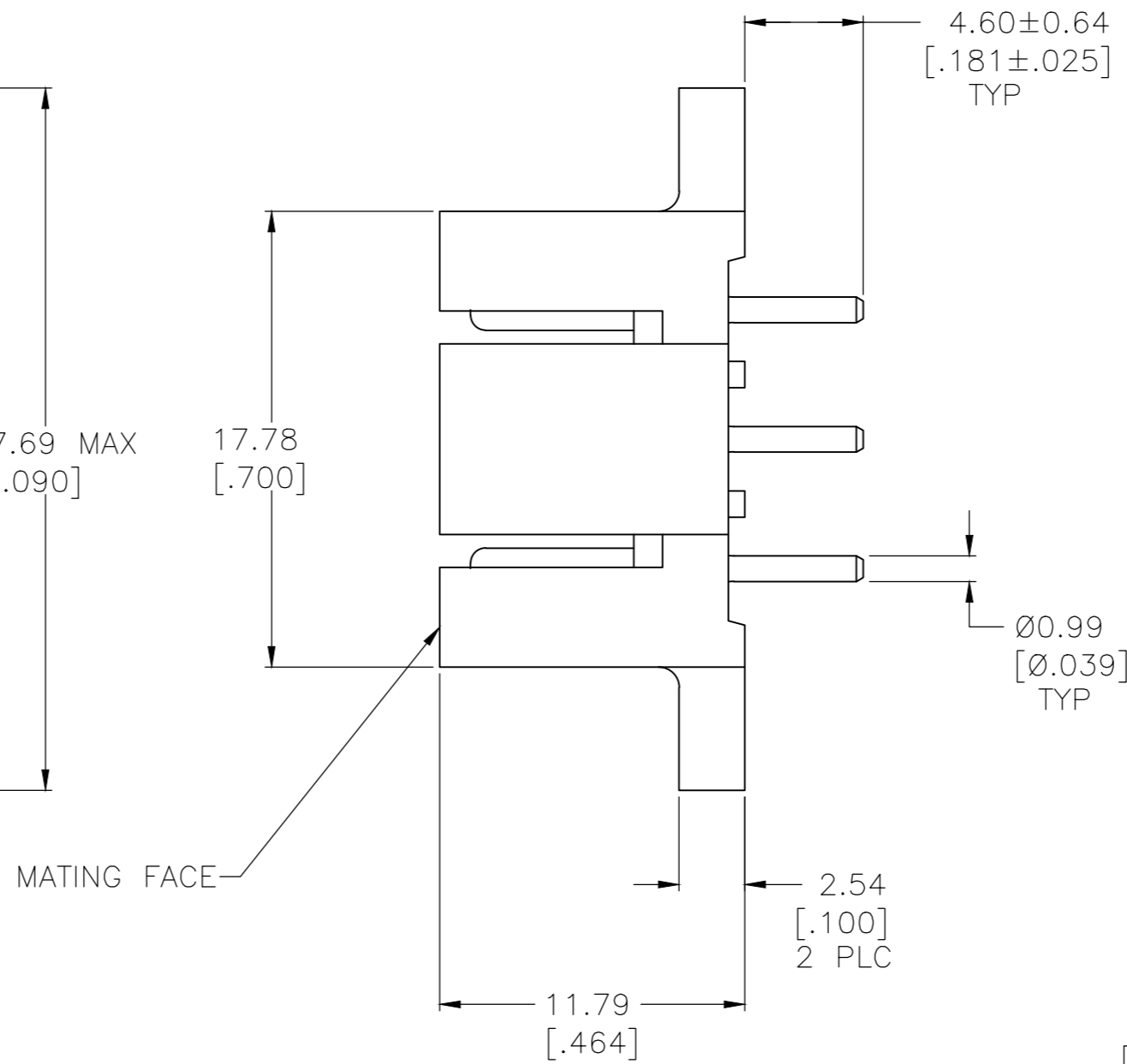
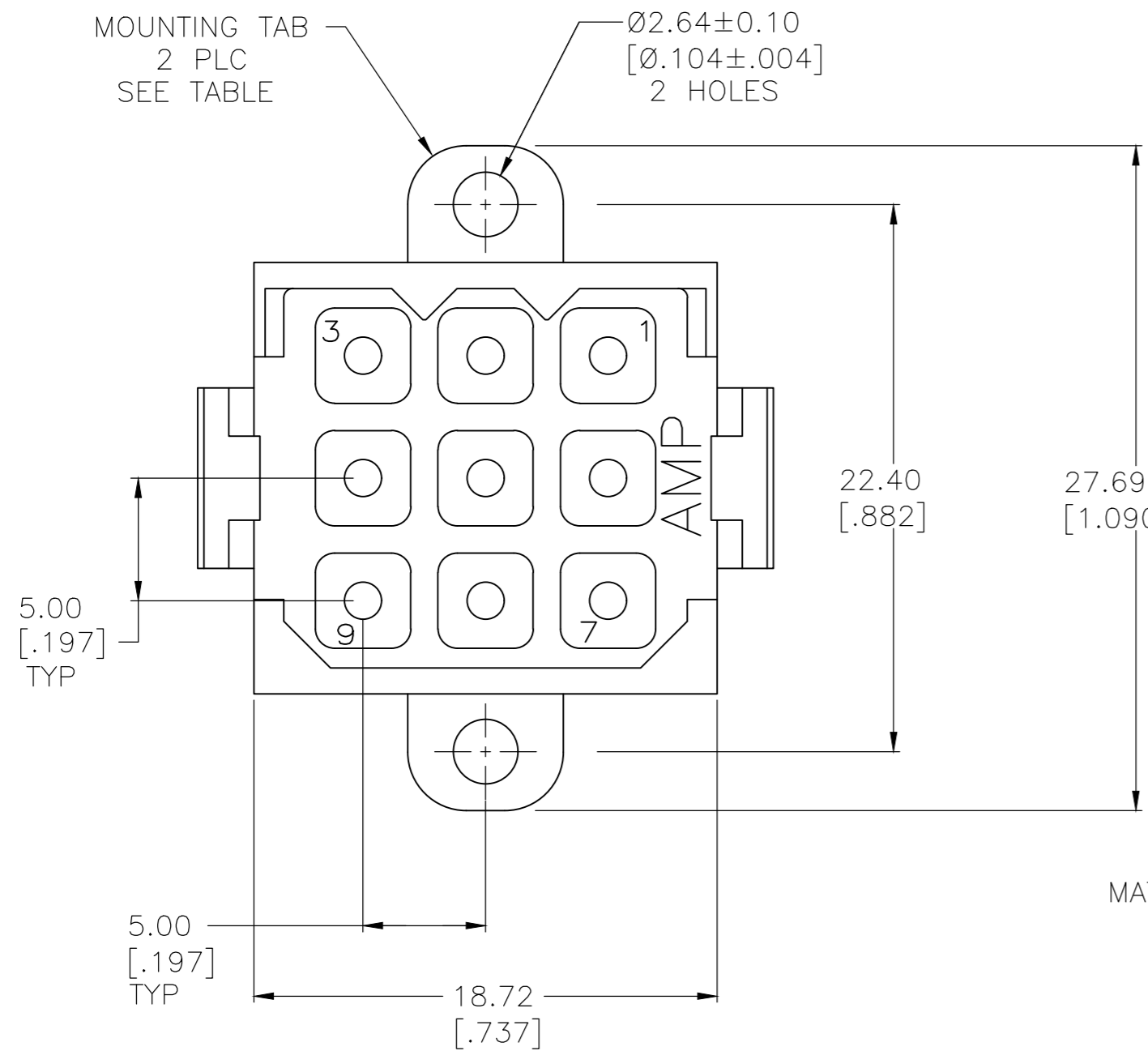
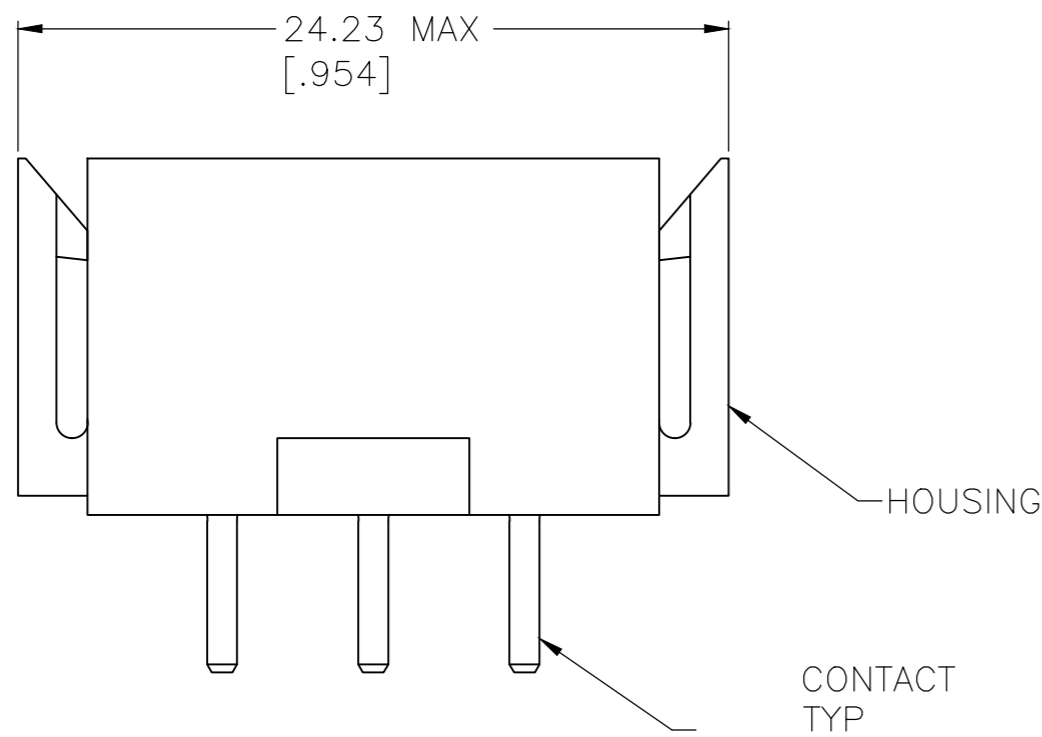

- ▲ HOUSING MATERIAL: PA66, BLACK, UL 94 V-0 RATED.
- ▲ CONTACT MATERIAL: BRASS PER ASTM B36.
- ▲ 3.81 μ m [.000150] MIN TIN OVER 2.54 μ m [.000100] MIN COPPER.
- ▲ 0.76 μ m [.000030] MIN GOLD FOR A LENGTH OF 5.08 [.200] FROM MATING END, 3.81 μ m [.000150] MIN TIN FOR A LENGTH OF 4.83 [.190] MIN FROM OPPOSITE END, BOTH OVER 1.27 μ m [.000050] MIN NICKEL.
- ▲ 3.81 μ m [.000150] MIN LEAD FREE TIN OVER 2.54 μ m [.000100] MIN COPPER.
- ▲ 0.76 μ m [.000030] MIN GOLD FOR A LENGTH OF 5.08 [.200] FROM MATING END, 3.81 μ m [.000150] MIN LEAD FREE TIN FOR A LENGTH OF 4.83 [.190] MIN FROM OPPOSITE END, BOTH OVER 1.27 μ m [.000050] MIN NICKEL.

| | | |
|----------------|-----|------------|
| 6 | YES | 1-207441-0 |
| 6 | NO | 207441-9 |
| 5 | NO | 207441-8 |
| 5 | YES | 207441-7 |
| 4 | NO | 207441-4 |
| 4 | YES | 207441-3 |
| 3 | NO | 207441-2 |
| 3 | YES | 207441-1 |
| CONTACT FINISH | | PART NO |
| MOUNTING TABS | | |

| | | | | | |
|--|--|---|-------------------|---|---------------|
| THIS DRAWING IS A CONTROLLED DOCUMENT. | | DWN | 03/10/92 | TE Connectivity | |
| | | L.SIPE | 3-17-92 | PIN HEADER ASSEMBLY, 9 POSITION, METRIMATE | |
| | | CHK | R.STONE | | |
| | | APVD | A.TRAVIS | | |
| | | PRODUCT SPEC | 108-10033 | | |
| | | APPLICATION SPEC | | | |
| DIMENSIONS: mm [INCHES] | | TOLERANCES UNLESS OTHERWISE SPECIFIED: | | SIZE | RESTRICTED TO |
| | | 0 PLC | \pm - | A2 | |
| | | 1 PLC | \pm - | CAGE CODE | |
| | | 2 PLC | \pm 0.25 [.010] | 00779 | |
| | | 3 PLC | \pm - | DRAWING NO | |
| | | 4 PLC | \pm - | C=207441 | |
| | | ANGLES | \pm - | SCALE | |
| MATERIAL | | FINISH | WEIGHT | SHEET | |
| HOUSING: ▲ | | CONTACT: SEE TABLE | - | 1 OF 1 | |
| CONTACT: ▲ | | | | REV | |
| | | | CUSTOMER DRAWING | | |

X-ON Electronics

Largest Supplier of Electrical and Electronic Components

Click to view similar products for [Headers & Wire Housings](#) category:

Click to view products by [TE Connectivity](#) manufacturer:

Other Similar products are found below :

[892-18-020-10-001101](#) [58102-G61-06LF](#) [582553-1](#) [0009485154](#) [009176003701906](#) [0050291907](#) [LY20-4P-DT1-P1E-BR](#) [02.125.8002.8](#)
[609-3404](#) [61062-3](#) [61082-181009](#) [622-3653LF](#) [63453-116](#) [636-1030](#) [636-1427](#) [636-3427](#) [636-4007](#) [641938-9](#) [641991-4](#) [644827-2](#) [65817-010LF](#) [65817-015LF](#) [65863-015LF](#) [66207-023LF](#) [67095-007LF](#) [67601157](#) [68645-018](#) [68648-049](#) [70.362.1628.0](#) [70-4210](#) [70-4226B](#) [70-4853B](#) [707-5020](#) [707-5028](#) [71.350.2428.0](#) [71918-208LF](#) [71961-016LF](#) [733-134](#) [733-162](#) [754199-000](#) [760-3052](#) [787-8014-00](#) [79531-3000](#)
[FCN-360C032-B](#) [FCN-367T-T012/H](#) [FCN-723D010/2](#) [80.063.4001.1](#) [800-90-001-10-001000](#) [800-90-010-10-002000](#) [801-43-002-10-013000](#)