

LOC	DIST	REVISIONS			
P	LTR	DESCRIPTION	DATE	DN	APVD
D1	REVISED PER	ECO-11-005030	11MAR11	RK	HMR

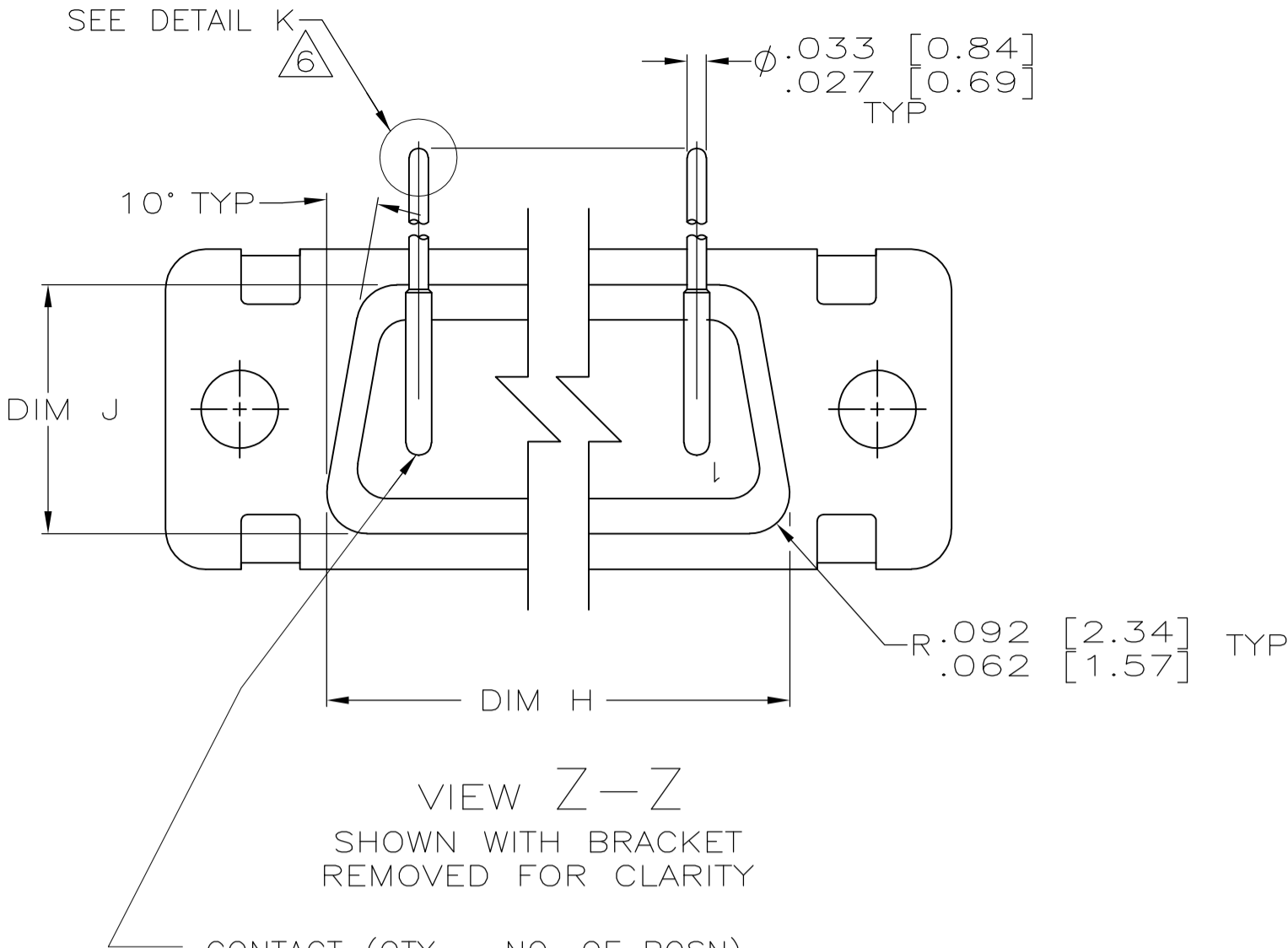

CONTACT (QTY = NO. OF POSN)  
 MATL: BRASS PER ASTM-B-16, OR BERYLLIUM COPPER PER ASTM-B-194  
 FINISH: GOLD PER MIL-G-45204, TYPE II, GRADE C, CLASS 1 IN CONTACT MATING AREA, .000010 [0.0003] MIN THK GOLD PER MIL-G-45204 OVER .000050 [0.0013] MIN THK NICKEL PER QQ-N-290 ON CONTACT BODY

- 1. SEE SHEET 2 FOR RECOMMENDED P.C. BOARD LAYOUT. TRUE POSITION TOLERANCE FOR P.C. BOARD LAYOUT IS .010 [0.25] AT MAX MATERIAL CONDITION. SUGGESTED BOARD THICKNESS IS .125 [3.18]
- 2. THE CONNECTORS DESCRIBED IN THIS DOCUMENT MEET THE REQUIREMENTS OF MIL-C-24308 AND MATE WITH ANY PLUG CONNECTOR WITH SAME INSERT ARRANGEMENT.
- 3. MARKED WITH .047 [1.19]-.062 [1.57] HIGH CHARACTERS. FAR SIDE REFERS TO THE WIDE SIDE OF THE KEYSTONE. NEAR SIDE REFERS TO THE NARROW SIDE OF THE KEYSTONE. IF THE REAR SHELL IS TOO SMALL FOR THE ENTIRE MILITARY PART NUMBER, MARKING SHALL BE LOCATED AS FOLLOWS:
  - A. "M24308" ON FRONT SHELL, FAR SIDE.
  - B. SLASH SHEET AND DASH NUMBER ON REAR SHELL, FAR SIDE.
  - C. "AMP" AND DATE CODE ON FRONT SHELL, NEAR SIDE.
  - D. AMP PART NUMBER ON REAR SHELL, NEAR SIDE.
- IF THE FRONT SHELL IS TOO SMALL FOR "AMP", PART NUMBER AND DATE CODE, MARKING SHALL BE SPLIT AS FOLLOWS:
  - A. PART NUMBER ON REAR SHELL, NEAR SIDE.
  - B. "AMP" AND DATE CODE ON FRONT SHELL, NEAR SIDE.
  - C. MILITARY PART NUMBER ON REAR SHELL, FAR SIDE.
- 4. POINT OF ELECTRICAL ENGAGEMENT - AS MEASURED WITH A .0390 [0.991]-.0393 [0.998] DIA SQUARE ENDED TEST PIN.
- 5. THIS DRAWING SHALL BE INTERPRETED IN ACCORDANCE WITH APPLICABLE STANDARDS LISTED IN MIL-STD-100.
- 6. SOLDER DIP PER MIL-STD-2000 COMPOSITION Sn63 CONFORMING TO QQ-S-571 IN THE ENTIRE AREA OF DIMENSION SHOWN. 1218434-6 THRU -10 ONLY.

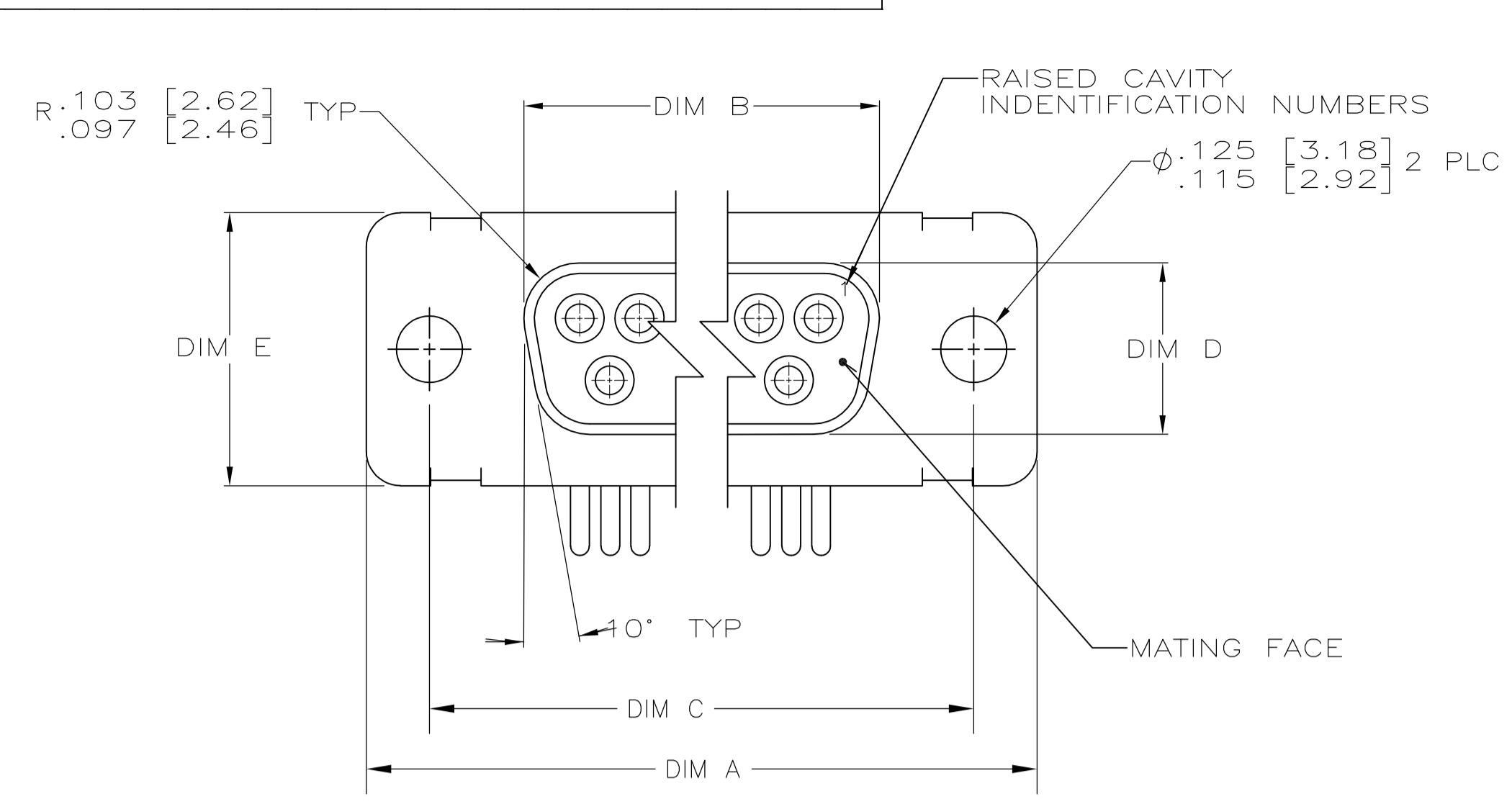
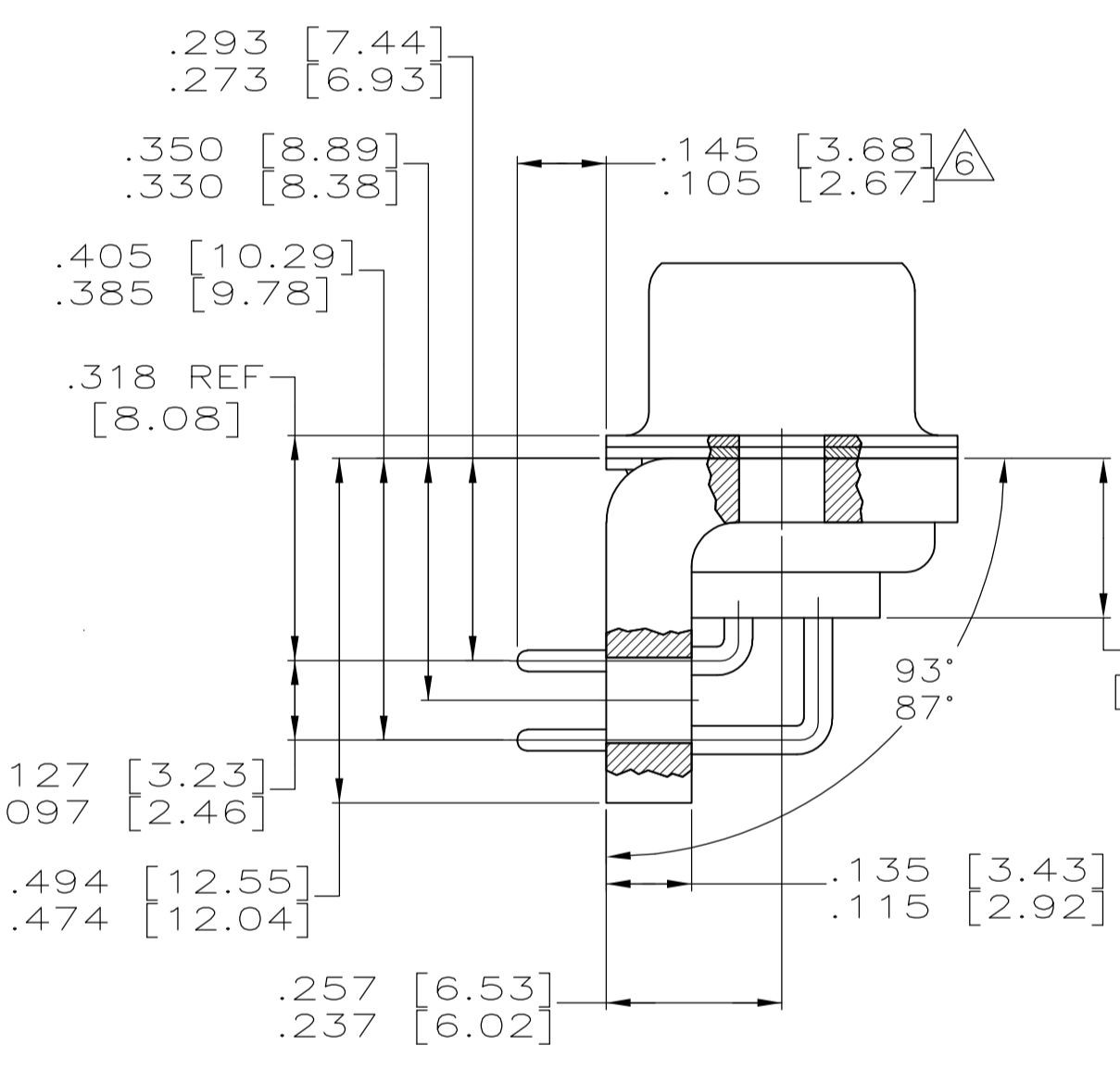
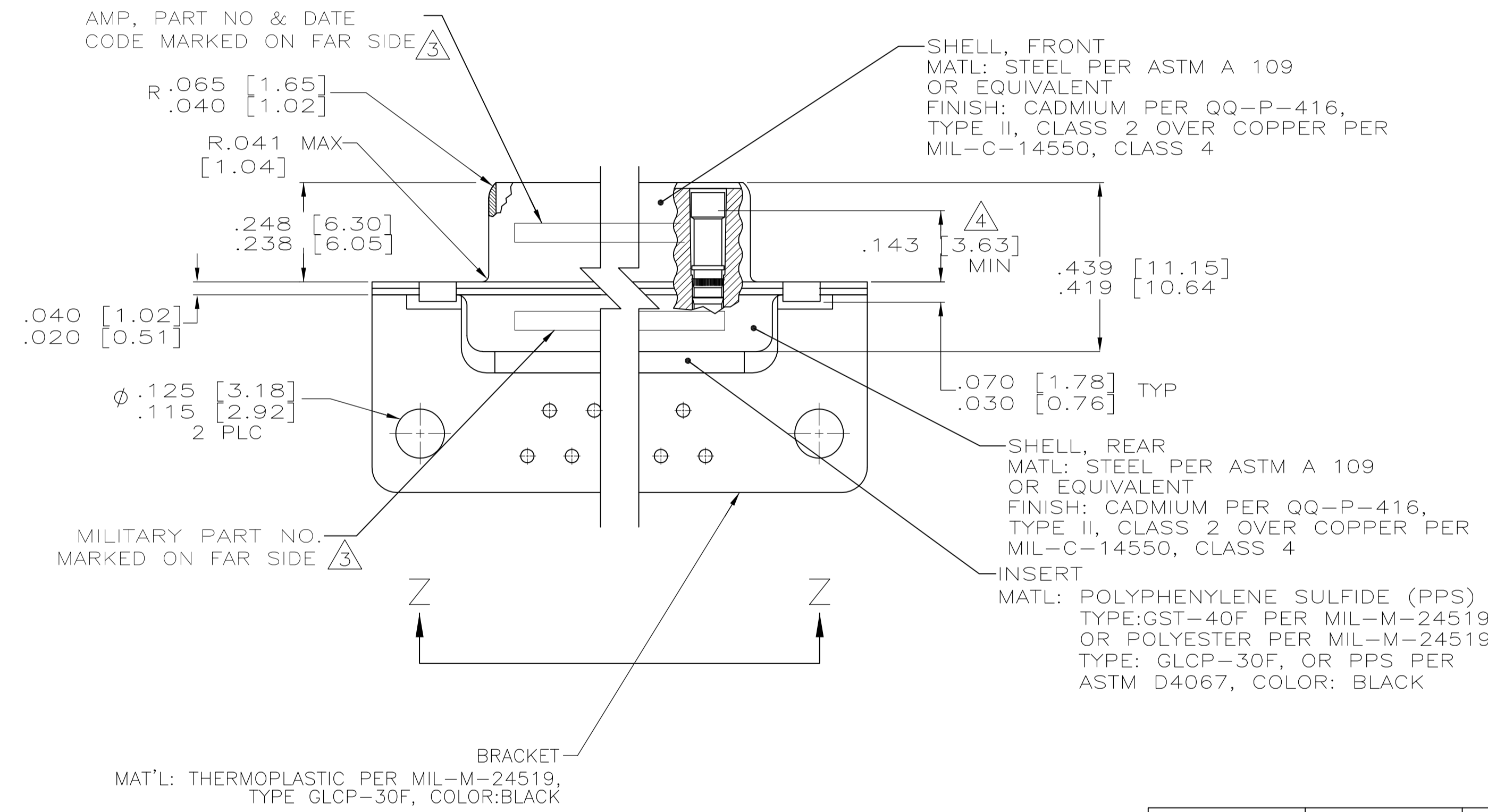

SHELL SIZES 1 THRU 4 CONTACT CONFIGURATION

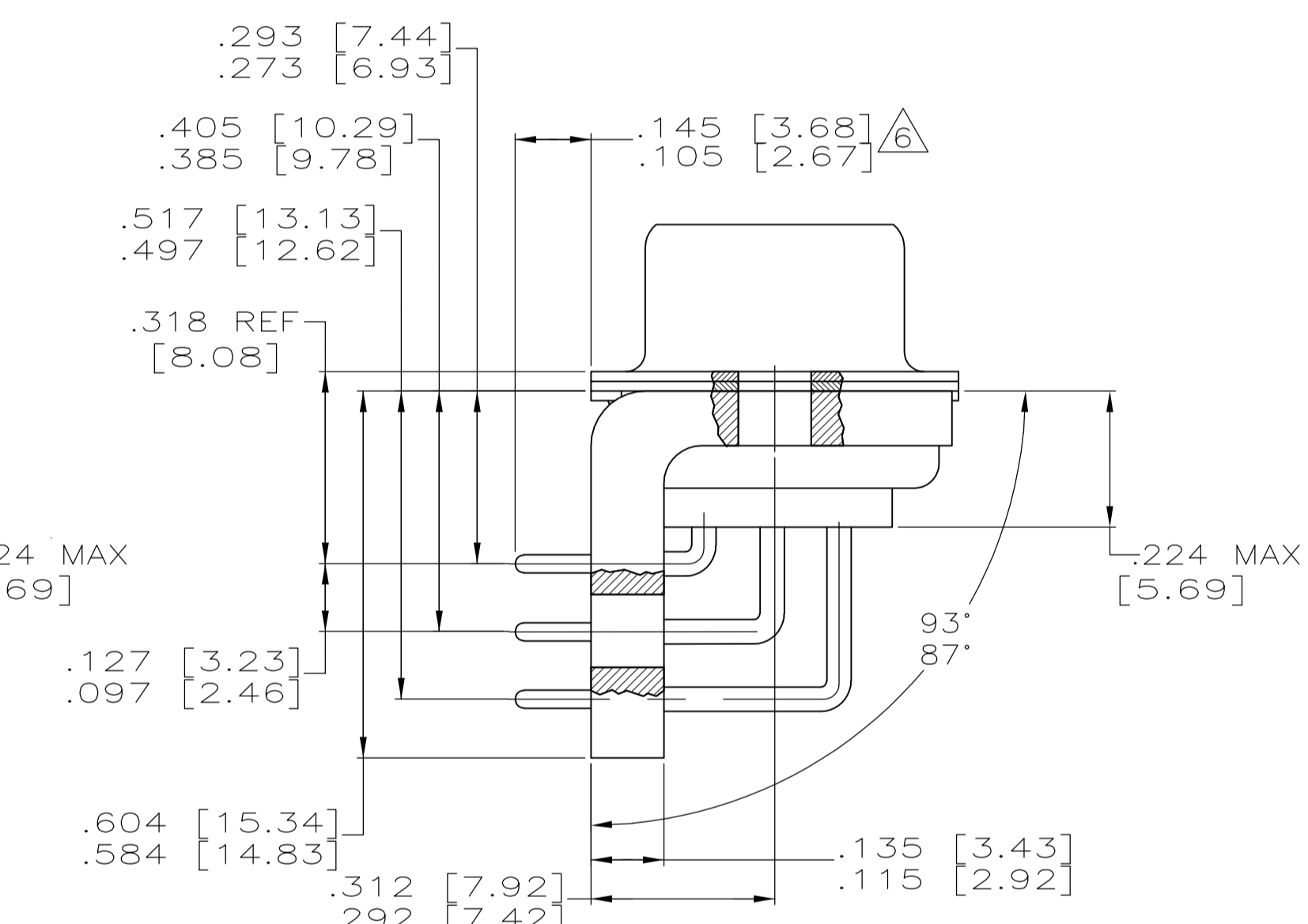

SHELL SIZE 5 CONTACT CONFIGURATION

.544 [13.82]	2.188 [55.58]	.620 [15.75]	.428 [10.87]	2.411 [61.24]	2.069 [52.55]	2.650 [67.31]
.524 [13.31]	2.168 [55.07]	.590 [14.99]	.418 [10.62]	2.401 [60.99]	2.059 [52.30]	2.620 [66.55]
.432 [10.97]	2.282 [57.96]	.509 [12.93]	.316 [8.03]	2.505 [63.63]	2.164 [54.97]	2.744 [69.70]
.412 [10.46]	2.262 [57.45]	.479 [12.17]	.306 [7.77]	2.495 [63.37]	2.154 [54.71]	2.714 [68.94]
.432 [10.97]	1.635 [41.53]	.509 [12.93]	.316 [8.03]	1.857 [47.17]	1.516 [38.51]	2.103 [53.42]
.412 [10.46]	1.615 [41.02]	.479 [12.17]	.306 [7.77]	1.847 [46.91]	1.506 [38.25]	2.073 [52.65]
.432 [10.97]	1.093 [27.76]	.509 [12.93]	.316 [8.03]	1.317 [33.45]	.976 [24.79]	1.556 [39.52]
.412 [10.46]	1.073 [27.25]	.479 [12.17]	.306 [7.77]	1.307 [33.20]	.966 [24.54]	1.526 [38.76]
.432 [10.97]	.769 [19.53]	.509 [12.93]	.316 [8.03]	.989 [25.12]	.648 [16.46]	1.228 [31.19]
.412 [10.46]	.749 [19.02]	.479 [12.17]	.306 [7.77]	.979 [24.87]	.638 [16.21]	1.198 [30.43]
.544 [13.82]	2.188 [55.58]	.620 [15.75]	.428 [10.87]	2.411 [61.24]	2.069 [52.55]	2.650 [67.31]
.524 [13.31]	2.168 [55.07]	.590 [14.99]	.418 [10.62]	2.401 [60.99]	2.059 [52.30]	2.620 [66.55]
.432 [10.97]	2.282 [57.96]	.509 [12.93]	.316 [8.03]	2.505 [63.63]	2.164 [54.97]	2.744 [69.70]
.412 [10.46]	2.262 [57.45]	.479 [12.17]	.306 [7.77]	2.495 [63.37]	2.154 [54.71]	2.714 [68.94]
.432 [10.97]	1.635 [41.53]	.509 [12.93]	.316 [8.03]	1.857 [47.17]	1.516 [38.51]	2.103 [53.42]
.412 [10.46]	1.615 [41.02]	.479 [12.17]	.306 [7.77]	1.847 [46.91]	1.506 [38.25]	2.073 [52.65]
.432 [10.97]	1.093 [27.76]	.509 [12.93]	.316 [8.03]	1.317 [33.45]	.976 [24.79]	1.556 [39.52]
.412 [10.46]	1.073 [27.25]	.479 [12.17]	.306 [7.77]	1.307 [33.20]	.966 [24.54]	1.526 [38.76]
.432 [10.97]	.769 [19.53]	.509 [12.93]	.316 [8.03]	.989 [25.12]	.648 [16.46]	1.228 [31.19]
.412 [10.46]	.749 [19.02]	.479 [12.17]	.306 [7.77]	.979 [24.87]	.638 [16.21]	1.198 [30.43]

DIM J	DIM H	DIM E	DIM D	DIM C	DIM B	DIM A	INSERT ARRANGEMENT	NO OF POS	SHELL SIZE	MILITARY P/N ON CONNECTOR	P/N MARKED ON CONNECTOR	PART NO.
50	50	5	M24308/23-29F	1218434-5	1-1218434-0							
37	37	4	M24308/23-28F	1218434-4	1218434-9							
25	25	3	M24308/23-27F	1218434-3	1218434-8							
15	15	2	M24308/23-26F	1218434-2	1218434-7							
9	9	1	M24308/23-25F	1218434-1	1218434-6							
50	50	5	M24308/23-29F	1218434-5	1218434-5							
37	37	4	M24308/23-28F	1218434-4	1218434-4							
25	25	3	M24308/23-27F	1218434-3	1218434-3							
15	15	2	M24308/23-26F	1218434-2	1218434-2							
9	9	1	M24308/23-25F	1218434-1	1218434-1							

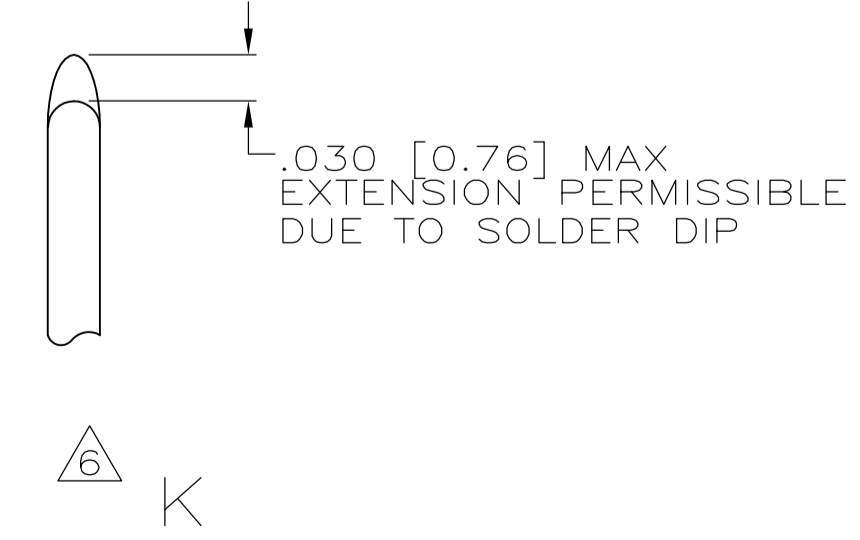

THIS DRAWING IS A CONTROLLED DOCUMENT.

INCHES: DIMENSIONS: TOLERANCES UNLESS OTHERWISE SPECIFIED: 0 PLC ± .005, 1 PLC ± .005, 2 PLC ± .005, 3 PLC ± .010 [0.25], 4 PLC ± .010 [0.25], ANGLES ± 1°

MATERIAL: FINISH: SEE CALLOUTS

WEIGHT: CUSTOMER DRAWING

SCALE: 4:1 SHEET 1 OF 2 REV D1

APPROVED: CHAD BAKER

DATE: 12-15-99

NAME: RECEPTACLE ASSY, AMPLIMITE RIGHT ANGLE, SERIES 109 SIZES 1 THRU 5

SIZE: A1 CASE CODE: 00779 DRAWING NO: 1218434

RESTRICTED TO: 1218434

LOC		DIST		REVISIONS				
DF	DO	P	LTR	DESCRIPTION	DATE	DN	APVD	
-	-	-	-	SEE SHEET 1	-	-	-	

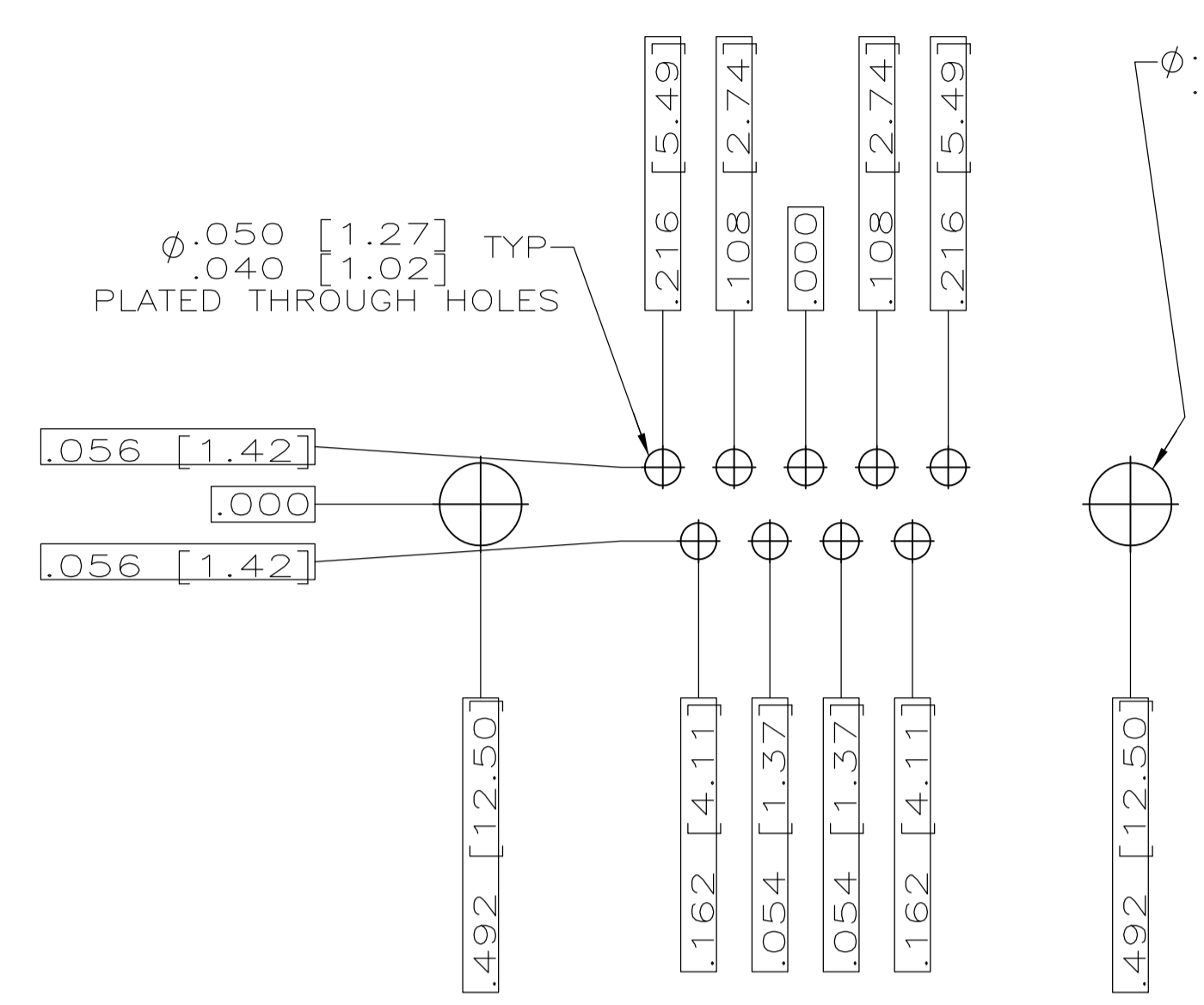

RECOMMENDED P.C. BOARD LAYOUT  
SHELL SIZE 1 (9 POSITION)



RECOMMENDED P.C. BOARD LAYOUT  
SHELL SIZE 2 (15 POSITION)



RECOMMENDED P.C. BOARD LAYOUT  
SHELL SIZE 3 (25 POSITION)

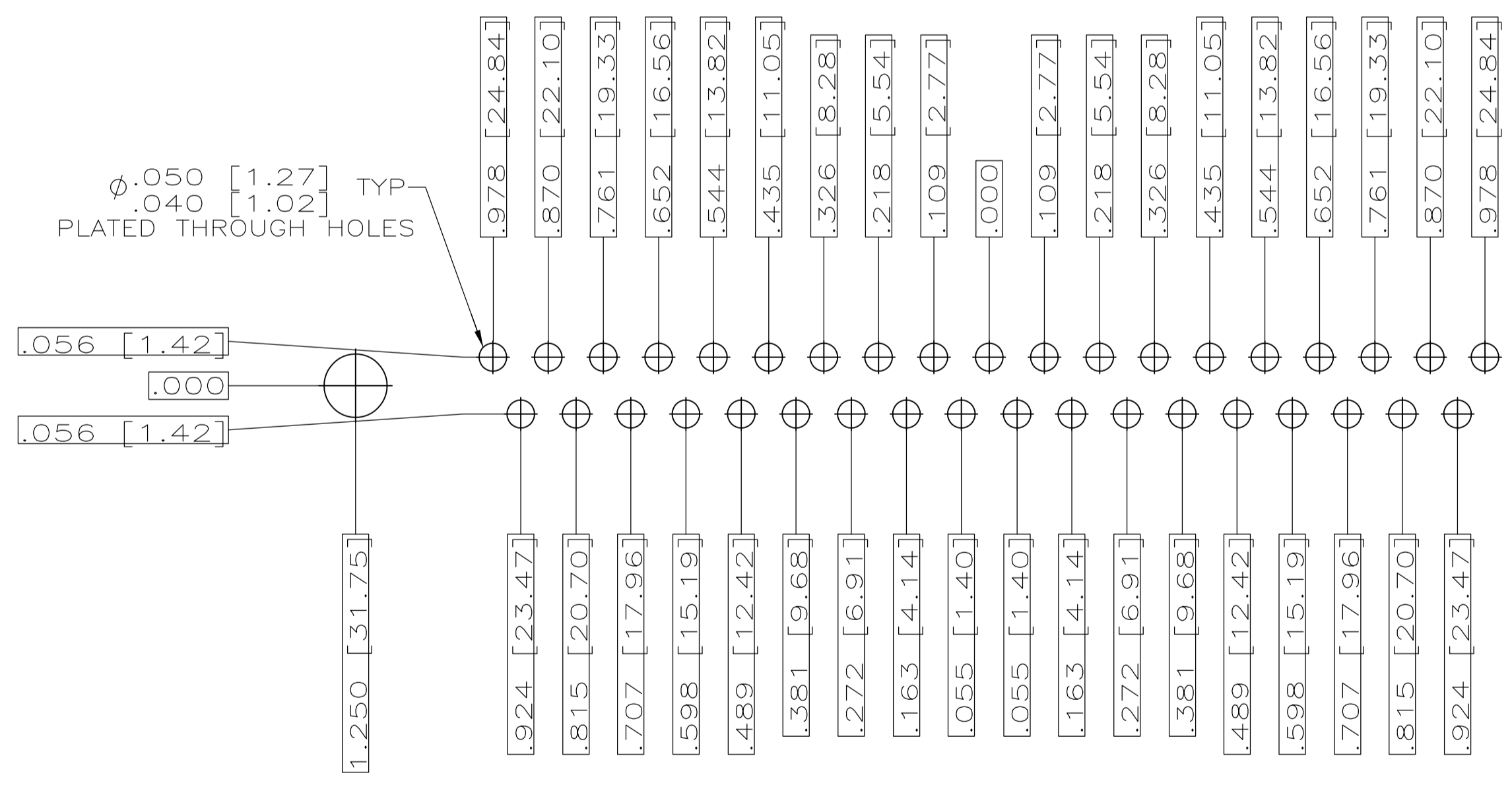

RECOMMENDED P.C. BOARD LAYOUT  
SHELL SIZE 4 (37 POSITION)



RECOMMENDED P.C. BOARD LAYOUT  
SHELL SIZE 5 (50 POSITION)  $\Delta$

THIS DRAWING IS A CONTROLLED DOCUMENT.		DN C.C.THOMAS 12-3-99	 TE Connectivity
DIMENSIONS: INCHES		CHK CHAD BAKER 12-15-99	
TOLERANCES UNLESS OTHERWISE SPECIFIED: 0 PL ± .005 1 PL ± .005 2 PL ± .005 3 PL ± .010 (0.25) 4 PL ± .010 (0.25) ANGLES ± .4°		APVD CHAD BAKER 12-15-99	NAME RECEPTACLE ASSY,AMPLITE RIGHT ANGLE,SERIES 109,SIZE 1 THRU 5
MATERIAL SEE CALLOUTS		FINISH SEE CALLOUTS	SIZE A1
WEIGHT -		CAGE CODE 00779	DRAWING NO 1218434
CUSTOMER DRAWING		SCALE 4:1	SHEET 2 OF 2
		REV D1	

## X-ON Electronics

Largest Supplier of Electrical and Electronic Components

*Click to view similar products for [D-Sub Standard Connectors](#) category:*

*Click to view products by [TE Connectivity](#) manufacturer:*

Other Similar products are found below :

[DCM37S732N](#) [DAM15P500](#) [DEV09S364GTLF](#) [DEM09P032N](#) [DDM50P732N](#) [DAM15S332N](#) [173109-2218](#) [173109-2466](#) [173109-2469](#)  
[173109-2435](#) [56F706-005-LI](#) [56F711-015](#) [015-0341-000](#) [017041-0005](#) [012-9507-114](#) [012-9534-001](#) [609-25P](#) [M24308/2-23Z](#) [M243082310F](#)  
[M24308/2-36Z](#) [M243082411F](#) [M24308315F](#) [M24308/4-21](#) [M243084437F](#) [CT0M22-23SS](#) [CT1N36-5SC](#) [CT2-16S-17PS](#) [CT2-20-15PCAU](#)  
[CT2-24-12PS](#) [CT2-24-28PSF127A206](#) [CT6F9767-14-4-14S-5PC](#) [CT7-18-10SC](#) [CT7-18-10SCAU](#) [CT7-18-12SCAU](#) [CT7-18-1PC](#) [CT7-18-](#)  
[1PCAU](#) [CT7-18-1SC](#) [CT7-18-21SCAU](#) [CT9-16-12PS](#) [M83513/01-FC](#) [M83723/76W24619 L/C](#) [M85049/48-3-2F](#) [69001-865](#)  
[6STD09PCM99B70X](#) [6STD09SCM99B30X](#) [6STD09SCT99S40X](#) [6STD15PCT99S40X](#) [6STD15SCM99B30X](#) [6STD15SCT99S40X](#)  
[6STF09PCM05B70X](#)