

- SEE SHEET 2 FOR RECOMMENDED P.C. BOARD LAYOUT
  - TRUE POSITION TOLERANCE FOR P.C. BOARD LAYOUT IS .010 AT MAXIMUM MATERIAL CONDITION.
  - REPLACEMENT CONTACT AMP PART NO 207684-3
  - THESE CONNECTORS MATE WITH ANY PLUG CONNECTORS OF THE SAME CONFIGURATION AS DEFINED BY MIL-C-24308.
- △ MARKED WITH .047-.062 HIGH CHARACTERS  
 FAR SIDE REFERS TO THE WIDE SIDE OF THE KEYSTONE  
 NEAR SIDE REFERS TO THE NARROW SIDE OF THE KEYSTONE  
 IF THE REAR SHELL IS TOO SMALL FOR THE ENTIRE PART NUMBER, MARKING SHALL BE LOCATED AS FOLLOWS:  
 A. "AMP" AND DATE CODE ON FRONT SHELL, NEAR SIDE.  
 B. AMP PART NUMBER ON REAR SHELL, NEAR SIDE.
- △ POINT OF ELECTRICAL ENGAGEMENT - AS MEASURED WITH A SQUARE ENDED TEST PIN.

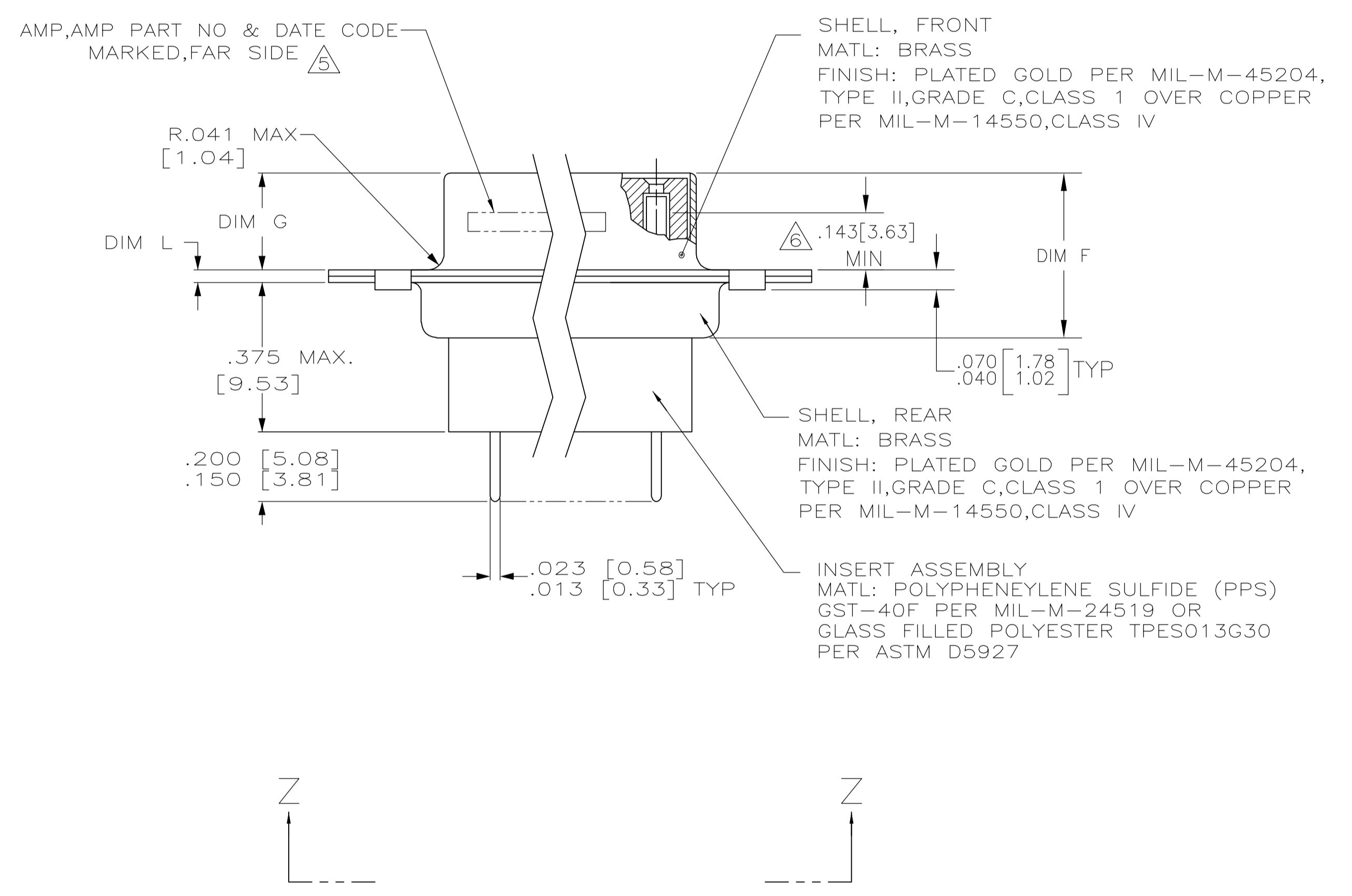

.049 [1.24]	.544 [13.82]	2.188 [55.58]	.248 [6.30]	.439 [11.15]	.620 [15.75]	.428 [10.87]	2.411 [61.24]	2.069 [52.55]	2.650 [67.31]	MS18277-2	78	5	1218697-5
.029 [0.74]	.524 [13.31]	2.168 [55.07]	.238 [6.05]	.419 [10.64]	.590 [14.99]	.418 [10.62]	2.401 [60.99]	2.059 [52.30]	2.620 [66.55]	MS18276-2	62	4	1218697-4
.040 [1.02]	.432 [10.97]	2.282 [57.96]	.248 [6.30]	.439 [11.15]	.509 [12.93]	.316 [8.03]	2.505 [63.63]	2.164 [54.97]	2.744 [69.70]	MS18274-2	26	2	1218697-2
.020 [0.51]	.412 [10.46]	2.262 [57.45]	.238 [6.05]	.419 [10.64]	.479 [12.17]	.306 [7.77]	2.495 [63.37]	2.154 [54.71]	2.714 [68.94]				
.040 [1.02]	.432 [10.97]	1.093 [27.76]	.248 [6.30]	.439 [11.15]	.509 [12.93]	.316 [8.03]	1.317 [33.45]	.976 [24.79]	1.556 [39.52]				
.020 [0.51]	.412 [10.46]	1.073 [27.25]	.238 [6.05]	.419 [10.64]	.479 [12.17]	.306 [7.77]	1.307 [33.20]	.966 [24.54]	1.526 [38.76]				
L	J	H	G	F	E	D	C	B	A	INSERT ARRANGEMENT	NO OF POS	SHELL SIZE	PART NUMBER

THIS DRAWING IS A CONTROLLED DOCUMENT.

DIMENSIONS: INCHES (MM)	TOLERANCES UNLESS OTHERWISE SPECIFIED:	DWG: C.C. THOMAS	DATE: 30MAR00		Tyco Electronics Corporation Harrisburg, PA 17105-3608
0 PLC ± - 1 PLC ± - 2 PLC ± - 3 PLC ± - 4 PLC ± - ANGLES ± 0°30'	FINISH SEE CALLOUTS	CHK: CHAD BAKER	DATE: 05APR00		
MATERIAL: SEE CALLOUTS	FINISH: SEE CALLOUTS	APVD: CHAD BAKER	DATE: 05APR00	NAME: CHAD BAKER	PRODUCT SPEC: AMPLIMITE ASSY, RECEPTACLE, NON-MAGNETIC, 90 SERIES, WITH CRIMP SNAP CONTACTS
		SIZE: A1	DATE CODE: 00779	DRAWING NO: 1218697	RESTRICTED TO: -
		CUSTOMER DRAWING	SCALE: 4:1	SHEET: 1 OF 2	REV: C

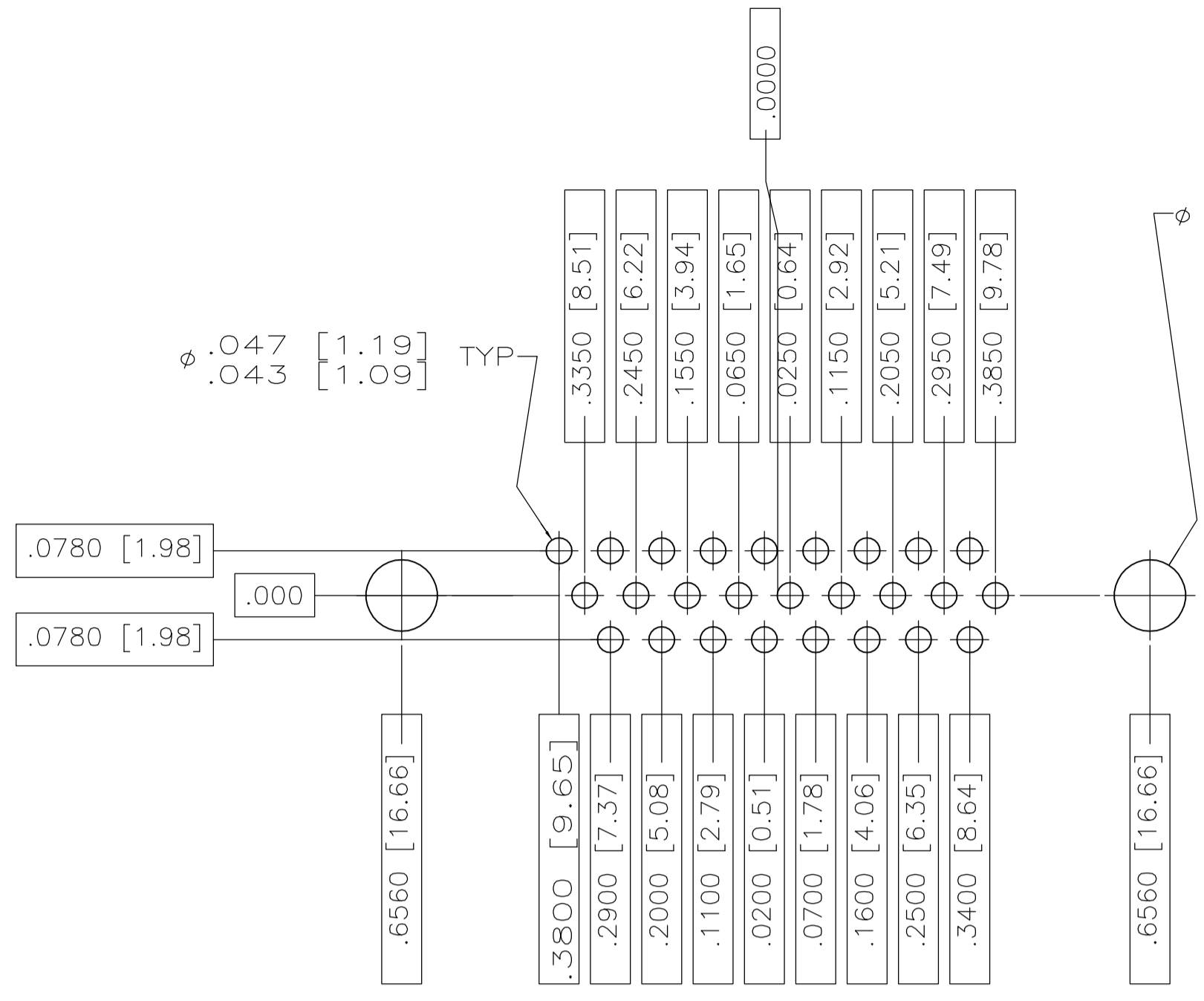

RECOMMENDED P.C. BOARD LAYOUT  
 SHELL SIZE 2 (26 POSITION)

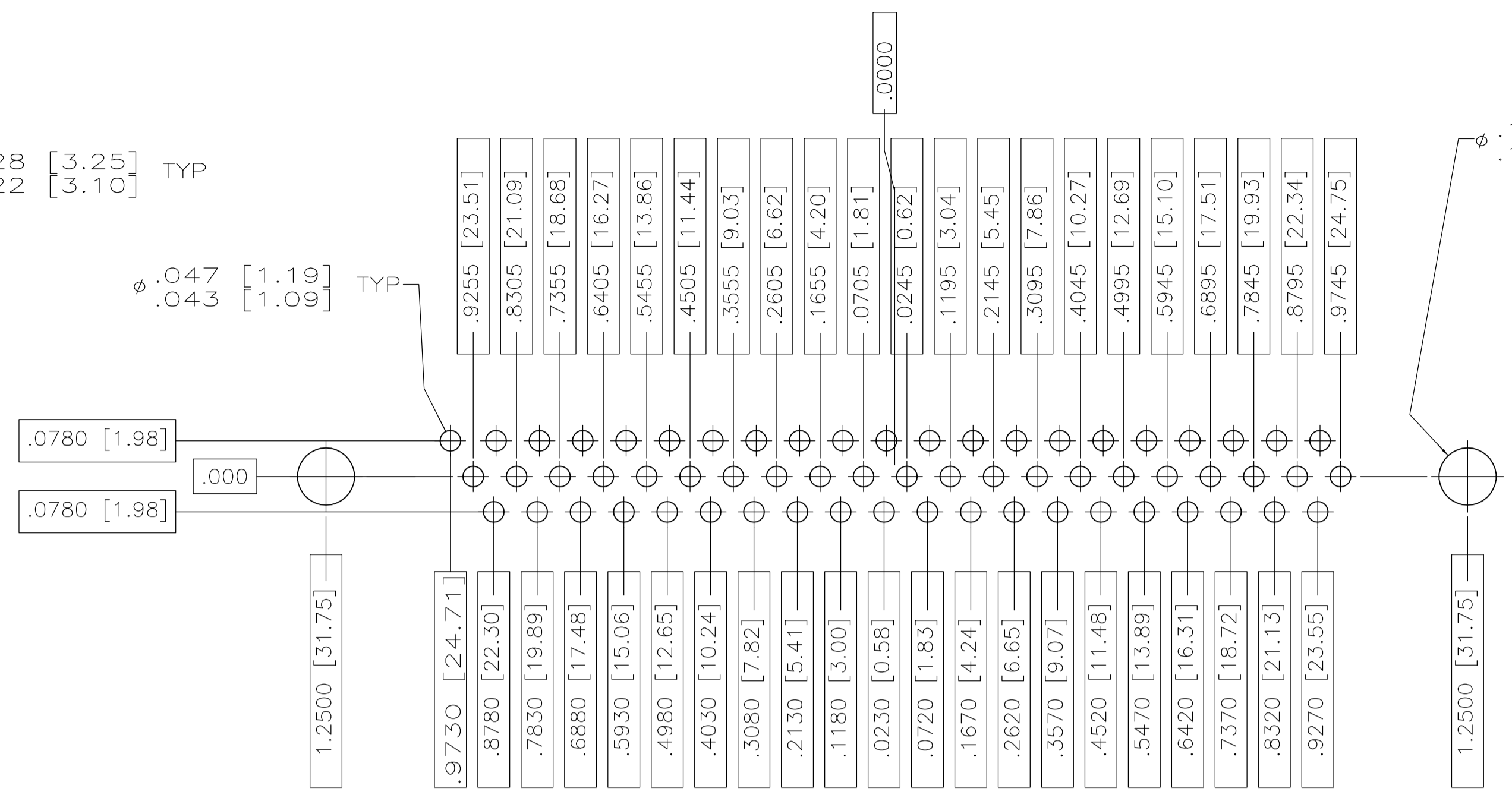

RECOMMENDED P.C. BOARD LAYOUT  
 SHELL SIZE 4 (62 POSITION)

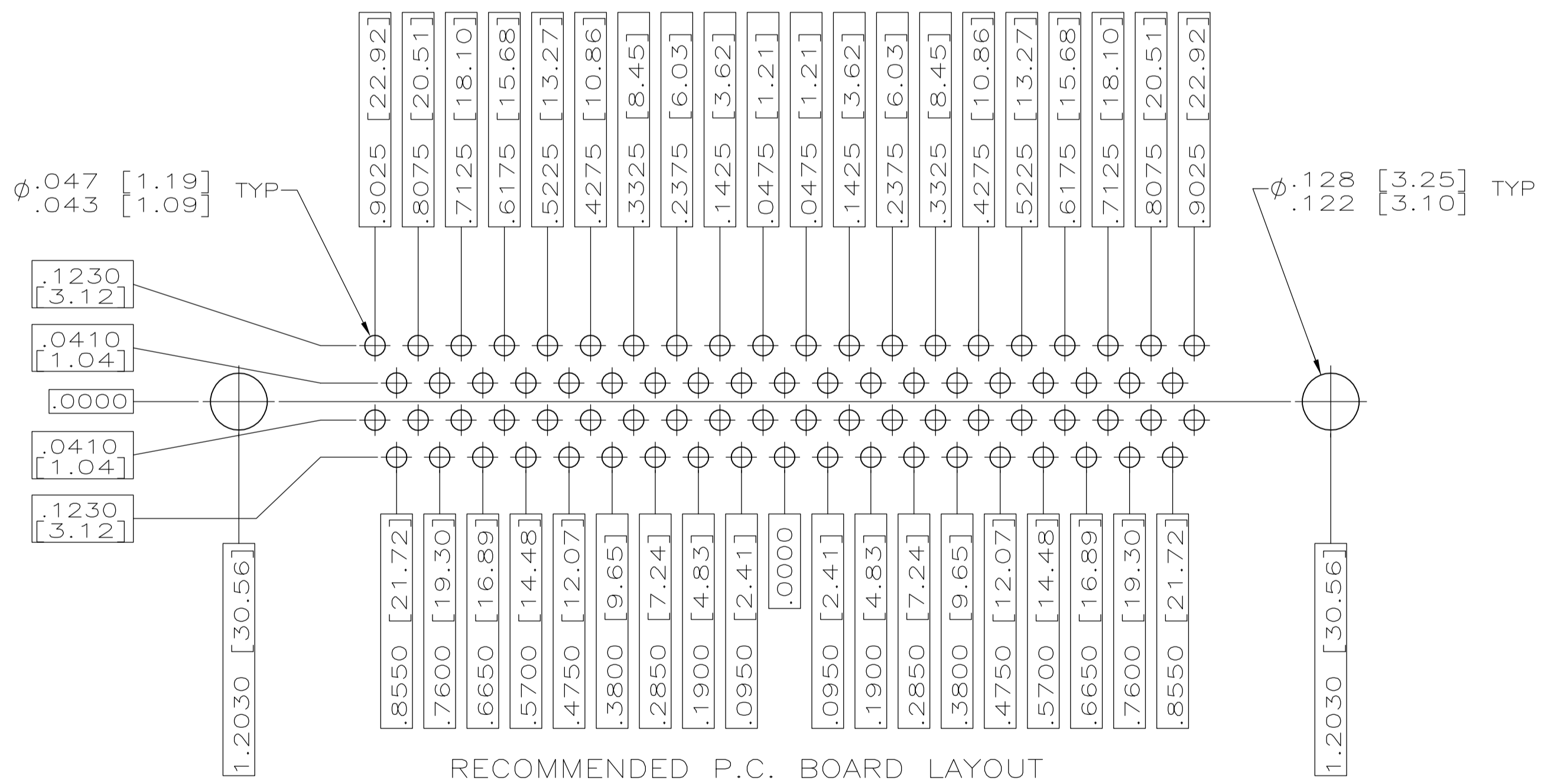

RECOMMENDED P.C. BOARD LAYOUT  
 SHELL SIZE 5 (78 POSITION)

THIS DRAWING IS A CONTROLLED DOCUMENT.		DWG C.C.THOMAS	DSAPROD	 Tyco Electronics Corporation Harrisburg, Pa 17105-3608
DIMENSIONS: INCHES [mm]		CHK CHAD BAKER	DSAPROD	
TOLERANCES UNLESS OTHERWISE SPECIFIED:		APVD CHAD BAKER	DSAPROD	NAME
0 PLC ± - 1 PLC ± - 2 PLC ± - 3 PLC ± .005 4 PLC ± - ANGLES ± -		PRODUCT SPEC		AMPLIMITE RCPT ASSY WITH LOADED POSTED CONTACTS NON-MAGNETIC,SERIES 90,SIZE 2 & 4-
MATERIAL SEE CALLOUTS		FINISH		APPLICATION SPEC
WEIGHT		SIZE A1	CAGE CODE 00779	DRAWING NO C=1218697
CUSTOMER DRAWING		SCALE 4:1		RESTRICTED TO
		SHEET 2 OF 2		REV C

## X-ON Electronics

Largest Supplier of Electrical and Electronic Components

*Click to view similar products for [D-Sub Standard Connectors](#) category:*

*Click to view products by [TE Connectivity](#) manufacturer:*

Other Similar products are found below :

[DCM37S732N](#) [DAM15P500](#) [DEV09S364GTLF](#) [DEM09P032N](#) [DDM50P732N](#) [DAM15S332N](#) [173109-2218](#) [173109-2466](#) [173109-2436](#)  
[173109-2435](#) [56F706-005-LI](#) [56F711-015](#) [015-0341-000](#) [015-0372-008](#) [015-8544-011](#) [017041-0005](#) [020419-0104](#) [012-0515-000](#) [012-9507-](#)  
[034](#) [012-9507-114](#) [012-9534-001](#) [020745-0008](#) [609-25P](#) [M24308/2-23Z](#) [M243082310F](#) [M243082410F](#) [M243082411F](#) [M24308/4-21](#)  
[CT1A18-11PSA206](#) [CT1N36-5SC](#) [CT2-16S-17PS](#) [CT2-20-15PCAU](#) [CT2-24-12PS](#) [CT2-24-28PSF127A206](#) [CT2-32-9PC](#) [CT6F9767-14-4-](#)  
[14S-5PC](#) [CT6FA10SL-4PS](#) [CT7-18-10SC](#) [CT7-18-10SCAU](#) [CT7-18-12SCAU](#) [CT7-18-1PC](#) [CT7-18-1PCAU](#) [CT7-18-21SCAU](#) [M83513/01-](#)  
[FC](#) [M83723/76W24619 L/C](#) [M85049/48-3-2F](#) [69001-865](#) [6STD09PCM99B70X](#) [6STD09SCM99B30X](#) [6STD09SCT99S40X](#)