

PROJEKT NR.:		REVISIONS				
		ÄNDERUNGEN	BESCHREIBUNG	DATE	DWN	APVD
C4	ECR-14-015440			16OCT2014	MN	Sche
C5	ECR-15-006287			22APR2015	SCK	Sche
C6	ECR-18-007266			09MAI2018	FRAN	SCH.

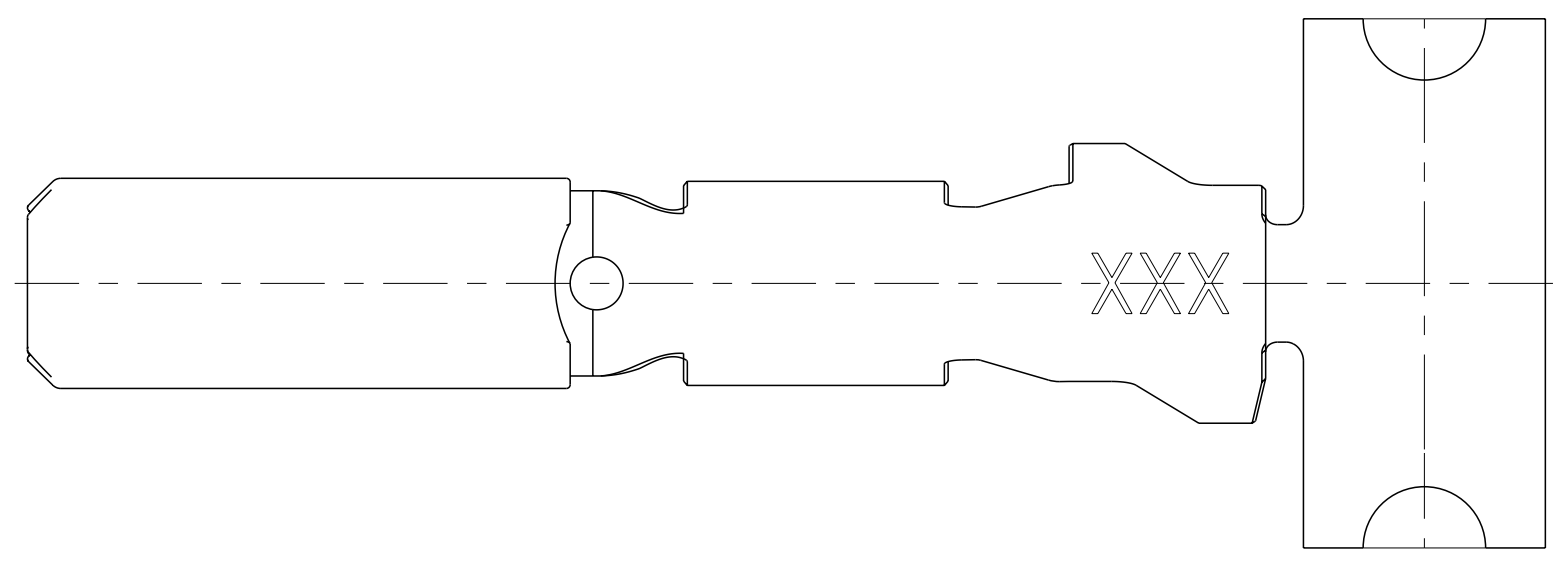

C6 Crimppausführung A
 CRIMP DESIGN A

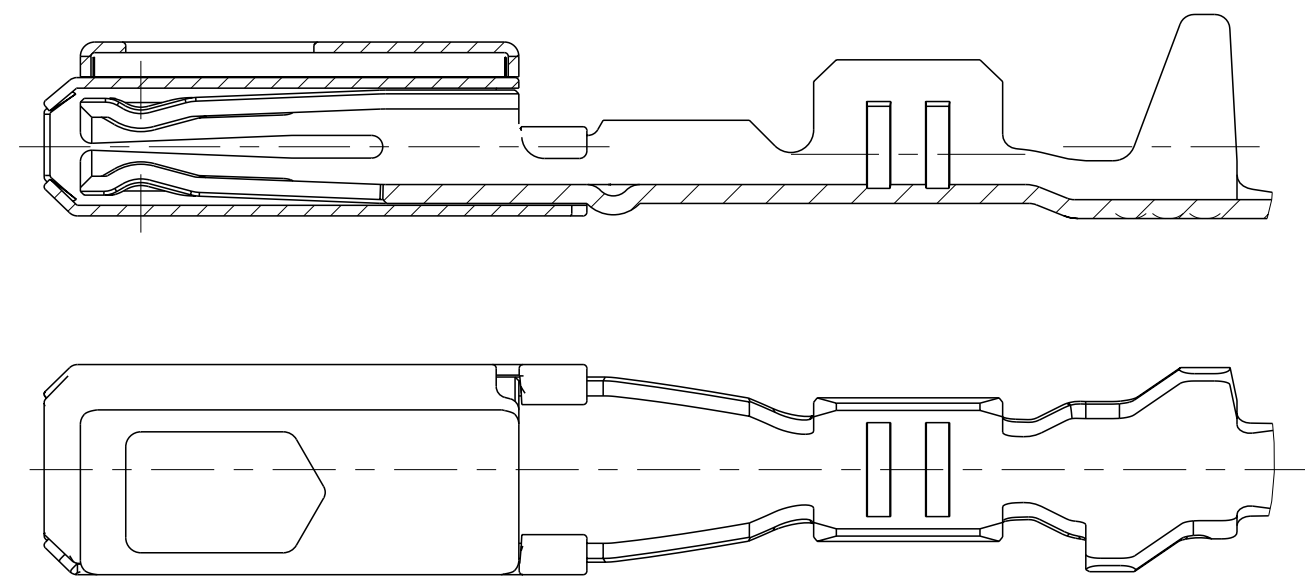

Crimppausführung C
 CRIMP DESIGN C

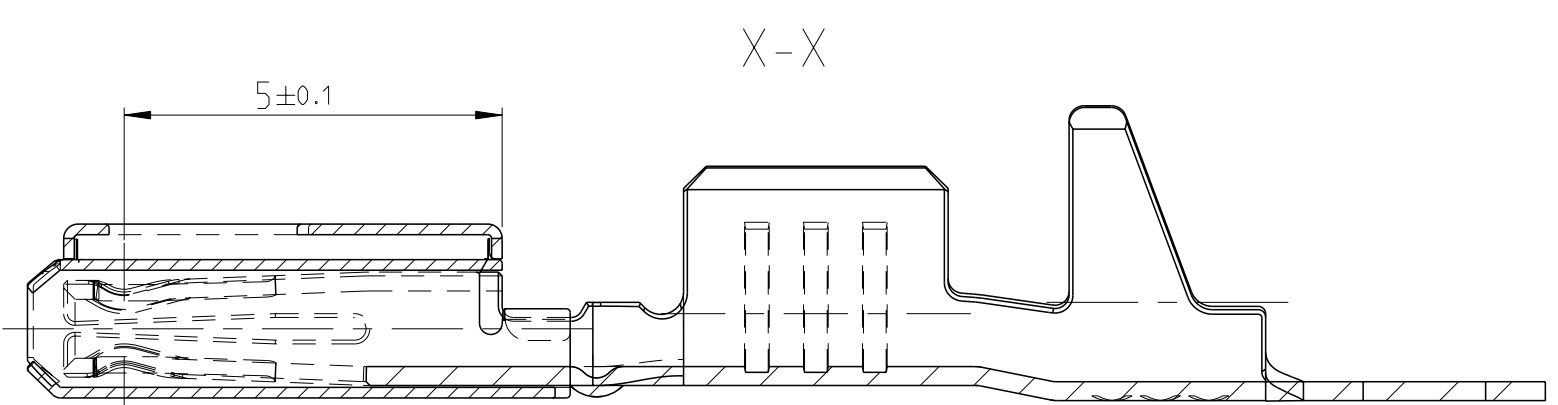
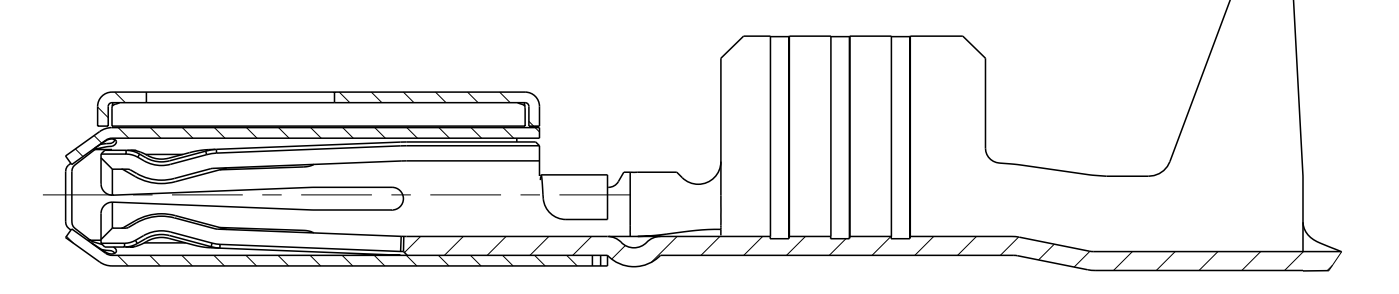

C6 Crimppausführung B
 CRIMP DESIGN B

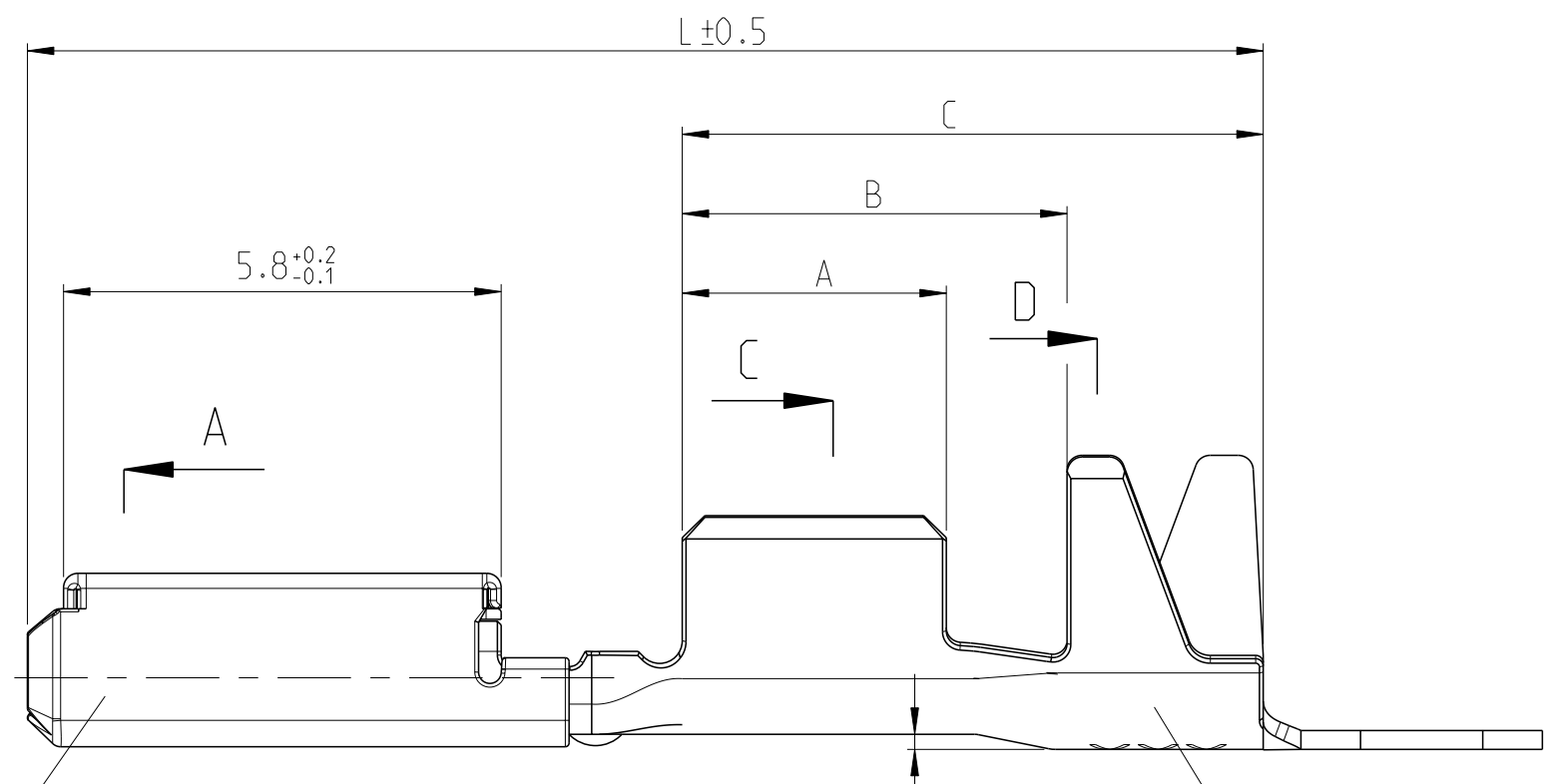
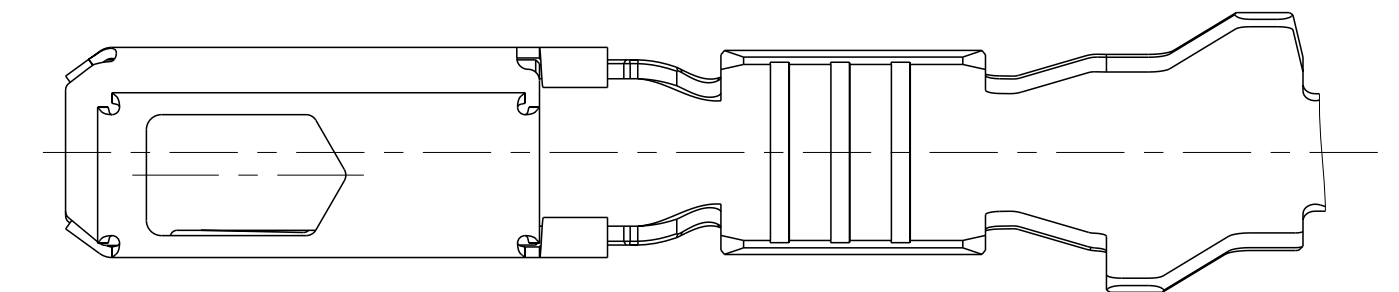
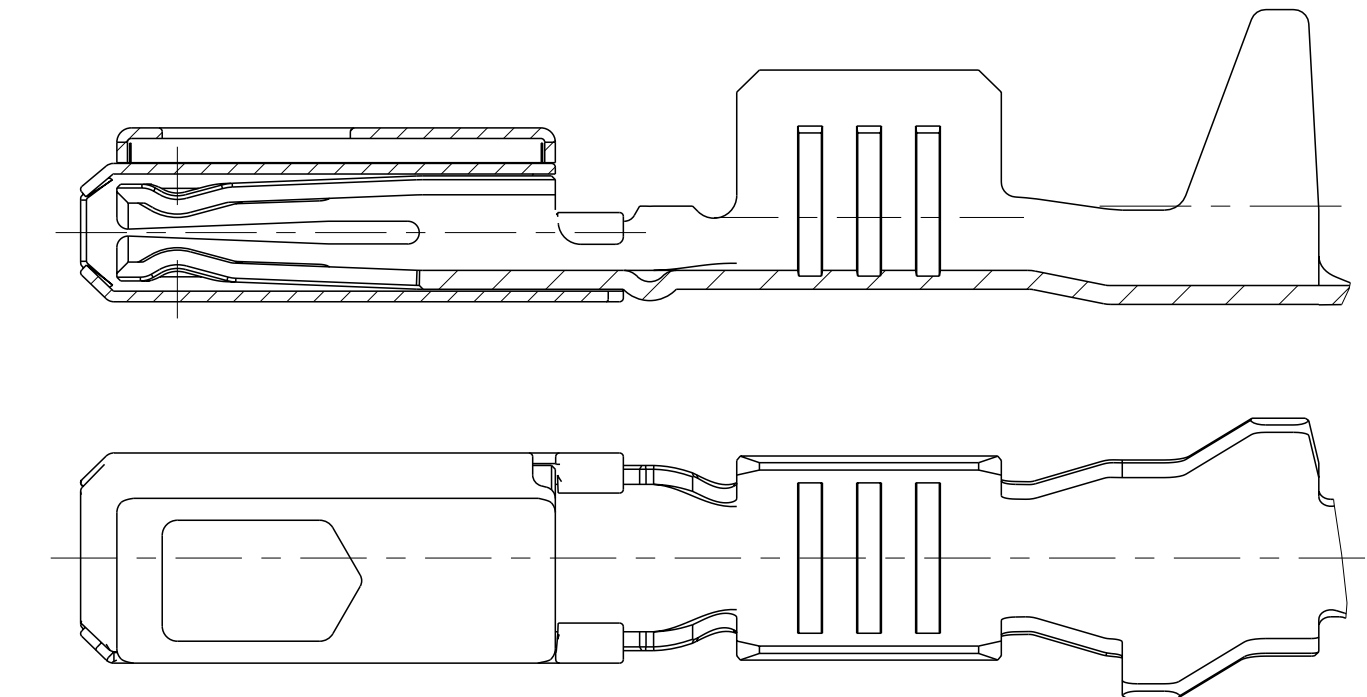

Kontaktkörper/BODY
 MATERIAL CuNiSi F57
 Oberfläche Zinn 0.8-2µm Sn
 Silber 1.6-4.6µm Ag ueber Ni im Kontaktbereich, Sn im Crimpbereich
 SURFACE TIN 0.8-2µm Sn
 SILVER 1.6-4.6µm Ag OVER Ni AT CONTACT AREA, Sn AT CRIMP AREA

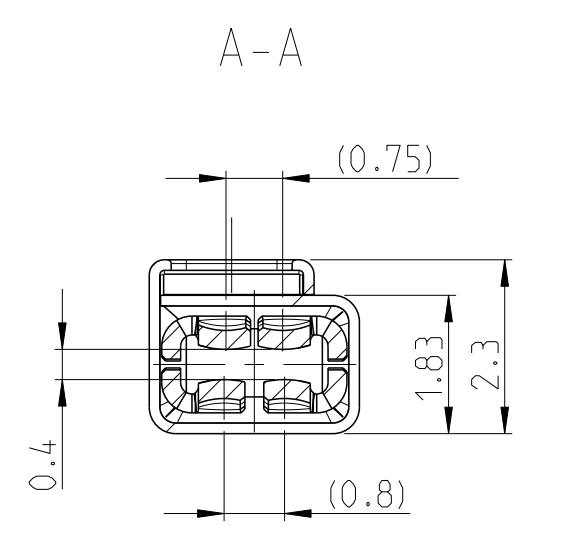

Ueberfeder/SPRING
 MATERIAL X10CrNi188
 Oberfläche blank
 SURFACE UNCOATED

Bemerkungen
 NOTES

- 1 Kontakt nur fuer Testzwecke (erhoehte Steckzyklenzahl), nicht fuer Serieneinsatz
 CONTACT ONLY FOR SPECIAL TEST-APPLICATIONS (HIGH MATING-CYCLES). NOT FOR SERIES-APPLICATION
- 2 Nur fuer FLR-Leitung nach DIN 72551, Teil 6
 FOR FLR-CONDUCTOR ACCORDING TO DIN 72551-6 ONLY
- 3 Einzelheiten der Ausfuehrung bleiben dem Hersteller ueberlassen
 DETAILS OF DESIGN ARE LEFT TO MANUFACTURER
- 4 Oberflaeche: blank, Material CuNi12Zn24
 SURFACE: UNCOATED, MATERIAL CuNi12Zn24
- C6 5 DATE-CODE (WEEK / YEAR (E.G. WEEK NUMBER 38 / YEAR 2007))
 Datumscode (Woche / Jahr, z. B. KW38 / Jahr 2007)
- C6 6 SUPPLIER MARK
 Lieferantenkennzeichnung
- C6 7 SUPPLIER REVISION INDEX
 Revisionsindex des Lieferanten
- C6 8 DIE-IDENTIFICATION
 Werkzeug-Kennzeichnung

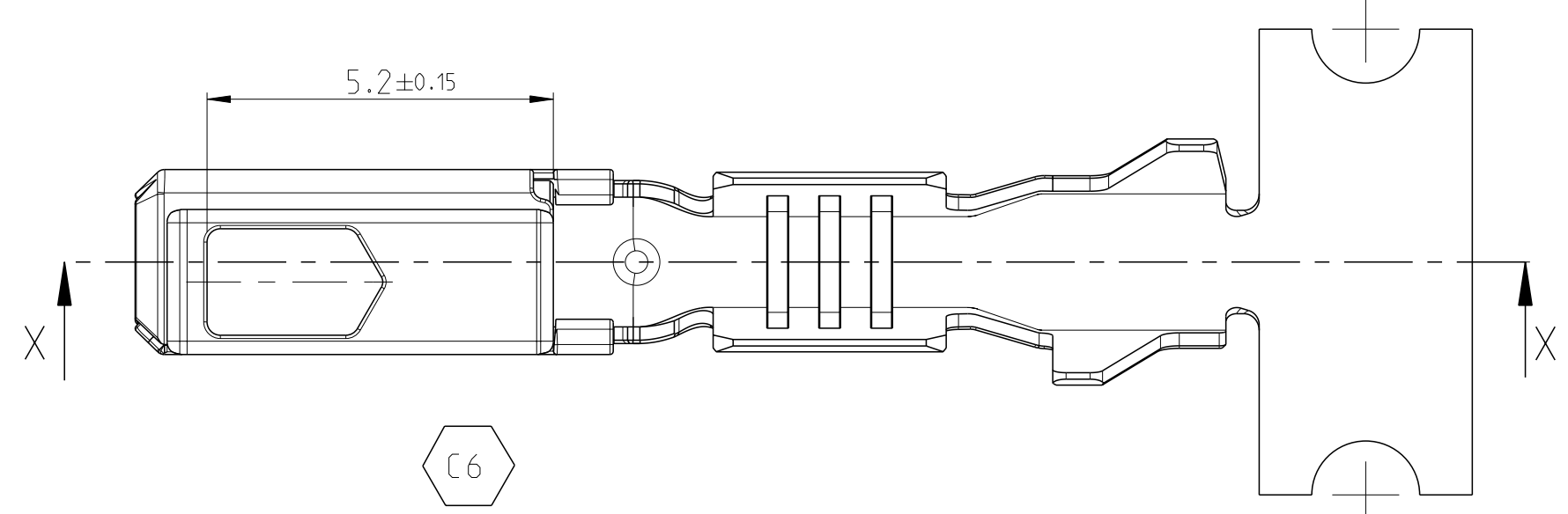

C6

TE BESTELL-NR. ORDER NO.	REV.	DGB WIRE-SIZE-RANGE mm 2	Oberflaeche SURFACE	Crimppausfuehrung CRIMP DESIGN	Gewicht WEIGHT g	Laenge LENGTH	Drahtcrimp WIRE CRIMP	Iso' crimp INSU.CRIMP
5-1241608-1	C	0.75...1.5	Sn	c	0.2	A = 3.5 B = 5.1 C = 7.7 L = 16.5	E = 2.7 G = 2.9 D _{DR} = 1.4	H = 3.7 K = 3.9 D _{ISO} = 2.1
1241608-6	C		Ag	B				
1241608-3	C		4	B				
1241608-2	C		Au	B				
1241608-1	C	0.35...0.5	Sn	B	0.2	A = 2.5 B = 3.6 C = 5.6 L = 15.8	E = 1.9 G = 1.9 D _{DR} = 0.8	H = 2.7 K = 2.7 D _{ISO} = 1.4
1452158-2	C		Au	A				
1452158-1	B		Sn	A				

Abmessungen/DIMENSIONS mm

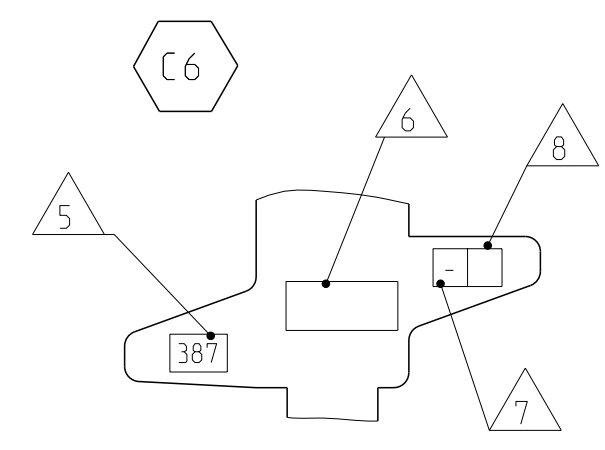
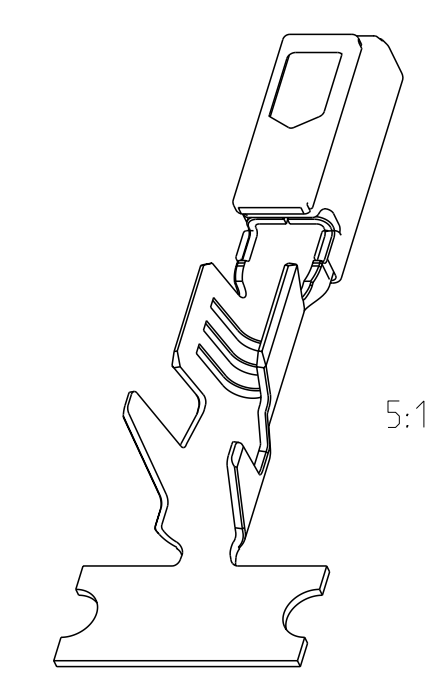
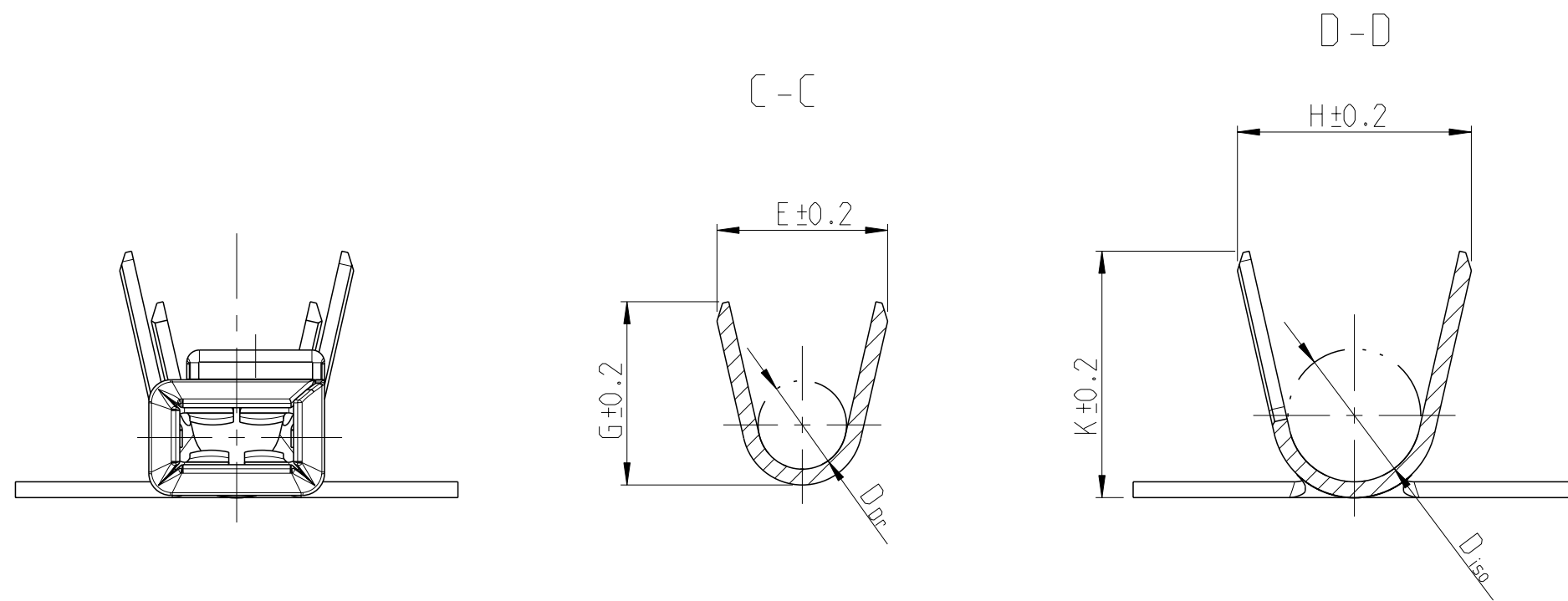

THIS DRAWING IS A CONTROLLED DOCUMENT.		DWN		DATE		SCALE	
OTHER DIMENSIONS: -		S. Garcia		04FEB2000		10:1	
TOLERANCES: UNLESS OTHERWISE SPECIFIED: -		C. Boemmel		04FEB2000		10:1	
DIMENSIONS: -		APVD		Jetter		10:1	
MASSEN/WEIGHTS: -		0 PLC ± DIN		PRODUCT SPEC		MATERIAL	
OTHER DIMENSIONS: -		1 PLC ± 6930- m		PRODUCT SPEC		MATERIAL	
OTHER DIMENSIONS: -		2 PLC ±		APPLICATION SPEC		MATERIAL	
OTHER DIMENSIONS: -		3 PLC ±		APPLICATION SPEC		MATERIAL	
OTHER DIMENSIONS: -		4 PLC ±		APPLICATION SPEC		MATERIAL	
OTHER DIMENSIONS: -		5 PLC ±		APPLICATION SPEC		MATERIAL	
OTHER DIMENSIONS: -		6 PLC ±		APPLICATION SPEC		MATERIAL	
OTHER DIMENSIONS: -		7 PLC ±		APPLICATION SPEC		MATERIAL	
OTHER DIMENSIONS: -		8 PLC ±		APPLICATION SPEC		MATERIAL	
OTHER DIMENSIONS: -		9 PLC ±		APPLICATION SPEC		MATERIAL	
OTHER DIMENSIONS: -		10 PLC ±		APPLICATION SPEC		MATERIAL	
OTHER DIMENSIONS: -		11 PLC ±		APPLICATION SPEC		MATERIAL	
OTHER DIMENSIONS: -		12 PLC ±		APPLICATION SPEC		MATERIAL	
OTHER DIMENSIONS: -		13 PLC ±		APPLICATION SPEC		MATERIAL	
OTHER DIMENSIONS: -		14 PLC ±		APPLICATION SPEC		MATERIAL	
OTHER DIMENSIONS: -		15 PLC ±		APPLICATION SPEC		MATERIAL	
OTHER DIMENSIONS: -		16 PLC ±		APPLICATION SPEC		MATERIAL	
OTHER DIMENSIONS: -		17 PLC ±		APPLICATION SPEC		MATERIAL	
OTHER DIMENSIONS: -		18 PLC ±		APPLICATION SPEC		MATERIAL	
OTHER DIMENSIONS: -		19 PLC ±		APPLICATION SPEC		MATERIAL	
OTHER DIMENSIONS: -		20 PLC ±		APPLICATION SPEC		MATERIAL	
OTHER DIMENSIONS: -		21 PLC ±		APPLICATION SPEC		MATERIAL	
OTHER DIMENSIONS: -		22 PLC ±		APPLICATION SPEC		MATERIAL	
OTHER DIMENSIONS: -		23 PLC ±		APPLICATION SPEC		MATERIAL	
OTHER DIMENSIONS: -		24 PLC ±		APPLICATION SPEC		MATERIAL	
OTHER DIMENSIONS: -		25 PLC ±		APPLICATION SPEC		MATERIAL	
OTHER DIMENSIONS: -		26 PLC ±		APPLICATION SPEC		MATERIAL	
OTHER DIMENSIONS: -		27 PLC ±		APPLICATION SPEC		MATERIAL	
OTHER DIMENSIONS: -		28 PLC ±		APPLICATION SPEC		MATERIAL	
OTHER DIMENSIONS: -		29 PLC ±		APPLICATION SPEC		MATERIAL	
OTHER DIMENSIONS: -		30 PLC ±		APPLICATION SPEC		MATERIAL	
OTHER DIMENSIONS: -		31 PLC ±		APPLICATION SPEC		MATERIAL	
OTHER DIMENSIONS: -		32 PLC ±		APPLICATION SPEC		MATERIAL	
OTHER DIMENSIONS: -		33 PLC ±		APPLICATION SPEC		MATERIAL	
OTHER DIMENSIONS: -		34 PLC ±		APPLICATION SPEC		MATERIAL	
OTHER DIMENSIONS: -		35 PLC ±		APPLICATION SPEC		MATERIAL	
OTHER DIMENSIONS: -		36 PLC ±		APPLICATION SPEC		MATERIAL	
OTHER DIMENSIONS: -		37 PLC ±		APPLICATION SPEC		MATERIAL	
OTHER DIMENSIONS: -		38 PLC ±		APPLICATION SPEC		MATERIAL	
OTHER DIMENSIONS: -		39 PLC ±		APPLICATION SPEC		MATERIAL	
OTHER DIMENSIONS: -		40 PLC ±		APPLICATION SPEC		MATERIAL	
OTHER DIMENSIONS: -		41 PLC ±		APPLICATION SPEC		MATERIAL	
OTHER DIMENSIONS: -		42 PLC ±		APPLICATION SPEC		MATERIAL	
OTHER DIMENSIONS: -		43 PLC ±		APPLICATION SPEC		MATERIAL	
OTHER DIMENSIONS: -		44 PLC ±		APPLICATION SPEC		MATERIAL	
OTHER DIMENSIONS: -		45 PLC ±		APPLICATION SPEC		MATERIAL	
OTHER DIMENSIONS: -		46 PLC ±		APPLICATION SPEC		MATERIAL	
OTHER DIMENSIONS: -		47 PLC ±		APPLICATION SPEC		MATERIAL	
OTHER DIMENSIONS: -		48 PLC ±		APPLICATION SPEC		MATERIAL	
OTHER DIMENSIONS: -		49 PLC ±		APPLICATION SPEC		MATERIAL	
OTHER DIMENSIONS: -		50 PLC ±		APPLICATION SPEC		MATERIAL	
OTHER DIMENSIONS: -		51 PLC ±		APPLICATION SPEC		MATERIAL	
OTHER DIMENSIONS: -		52 PLC ±		APPLICATION SPEC		MATERIAL	
OTHER DIMENSIONS: -		53 PLC ±		APPLICATION SPEC		MATERIAL	
OTHER DIMENSIONS: -		54 PLC ±		APPLICATION SPEC		MATERIAL	
OTHER DIMENSIONS: -		55 PLC ±		APPLICATION SPEC		MATERIAL	
OTHER DIMENSIONS: -		56 PLC ±		APPLICATION SPEC		MATERIAL	
OTHER DIMENSIONS: -		57 PLC ±		APPLICATION SPEC		MATERIAL	
OTHER DIMENSIONS: -		58 PLC ±		APPLICATION SPEC		MATERIAL	
OTHER DIMENSIONS: -		59 PLC ±		APPLICATION SPEC		MATERIAL	
OTHER DIMENSIONS: -		60 PLC ±		APPLICATION SPEC		MATERIAL	
OTHER DIMENSIONS: -		61 PLC ±		APPLICATION SPEC		MATERIAL	
OTHER DIMENSIONS: -		62 PLC ±		APPLICATION SPEC		MATERIAL	
OTHER DIMENSIONS: -		63 PLC ±		APPLICATION SPEC		MATERIAL	
OTHER DIMENSIONS: -		64 PLC ±		APPLICATION SPEC		MATERIAL	
OTHER DIMENSIONS: -		65 PLC ±		APPLICATION SPEC		MATERIAL	
OTHER DIMENSIONS: -		66 PLC ±		APPLICATION SPEC		MATERIAL	
OTHER DIMENSIONS: -		67 PLC ±		APPLICATION SPEC		MATERIAL	
OTHER DIMENSIONS: -		68 PLC ±		APPLICATION SPEC		MATERIAL	
OTHER DIMENSIONS: -		69 PLC ±		APPLICATION SPEC		MATERIAL	
OTHER DIMENSIONS: -		70 PLC ±		APPLICATION SPEC		MATERIAL	
OTHER DIMENSIONS: -		71 PLC ±		APPLICATION SPEC		MATERIAL	
OTHER DIMENSIONS: -		72 PLC ±		APPLICATION SPEC		MATERIAL	
OTHER DIMENSIONS: -		73 PLC ±		APPLICATION SPEC		MATERIAL	
OTHER DIMENSIONS: -		74 PLC ±		APPLICATION SPEC		MATERIAL	
OTHER DIMENSIONS: -		75 PLC ±		APPLICATION SPEC		MATERIAL	
OTHER DIMENSIONS: -		76 PLC ±		APPLICATION SPEC		MATERIAL	
OTHER DIMENSIONS: -		77 PLC ±		APPLICATION SPEC		MATERIAL	
OTHER DIMENSIONS: -		78 PLC ±		APPLICATION SPEC		MATERIAL	
OTHER DIMENSIONS: -		79 PLC ±		APPLICATION SPEC		MATERIAL	
OTHER DIMENSIONS: -		80 PLC ±		APPLICATION SPEC		MATERIAL	
OTHER DIMENSIONS: -		81 PLC ±		APPLICATION SPEC		MATERIAL	
OTHER DIMENSIONS: -		82 PLC ±		APPLICATION SPEC		MATERIAL	
OTHER DIMENSIONS: -		83 PLC ±		APPLICATION SPEC		MATERIAL	
OTHER DIMENSIONS: -		84 PLC ±		APPLICATION SPEC		MATERIAL	
OTHER DIMENSIONS: -		85 PLC ±		APPLICATION SPEC		MATERIAL	
OTHER DIMENSIONS: -		86 PLC ±		APPLICATION SPEC		MATERIAL	
OTHER DIMENSIONS: -		87 PLC ±		APPLICATION SPEC		MATERIAL	
OTHER DIMENSIONS: -		88 PLC ±		APPLICATION SPEC		MATERIAL	
OTHER DIMENSIONS: -		89 PLC ±		APPLICATION SPEC		MATERIAL	
OTHER DIMENSIONS: -		90 PLC ±		APPLICATION SPEC		MATERIAL	
OTHER DIMENSIONS: -		91 PLC ±		APPLICATION SPEC		MATERIAL	
OTHER DIMENSIONS: -		92 PLC ±		APPLICATION SPEC		MATERIAL	
OTHER DIMENSIONS: -		93 PLC ±		APPLICATION SPEC		MATERIAL	
OTHER DIMENSIONS: -		94 PLC ±		APPLICATION SPEC		MATERIAL	
OTHER DIMENSIONS: -		95 PLC ±		APPLICATION SPEC		MATERIAL	
OTHER DIMENSIONS: -		96 PLC ±		APPLICATION SPEC		MATERIAL	
OTHER DIMENSIONS: -		97 PLC ±		APPLICATION SPEC		MATERIAL	
OTHER DIMENSIONS: -		98 PLC ±		APPLICATION SPEC		MATERIAL	
OTHER DIMENSIONS: -		99 PLC ±		APPLICATION SPEC		MATERIAL	
OTHER DIMENSIONS: -		100 PLC ±		APPLICATION SPEC		MATERIAL	

X-ON Electronics

Largest Supplier of Electrical and Electronic Components

Click to view similar products for [Automotive Connectors](#) category:

Click to view products by [TE Connectivity](#) manufacturer:

Other Similar products are found below :

[003-018-000](#) [60403001](#) [60993906-B](#) [M902-2131](#) [M902-2161](#) [M902-2344](#) [72.330.1035.1](#) [73.353.4028.0](#) [F119300-B](#) [F166900](#) [F258300-B](#)
[F358300-B](#) [F407400](#) [F444110](#) [F487000](#) [F509500B-B](#) [827153-1](#) [8N1515-32-24P](#) [9-1326729-8](#) [925474-1](#) [928905-1](#) [964562-4](#) [968782-1](#)
[GT17SA-8DS-HU](#) [98891-1012](#) [98947-1016](#) [12004147](#) [12004475-L](#) [12010290](#) [12010309-B](#) [12015454](#) [12020219-B](#) [12041318-B](#) [12052225-](#)
[L](#) [12052466](#) [12064869](#) [12004327-B](#) [12015308](#) [12015384](#) [12015909](#) [1-21030-1](#) [12041254](#) [12041318](#) [12047946-B](#) [12047957](#) [12047957-L](#)
[12059473](#) [12066261](#) [12110546](#) [12110546-B](#)