

THIS DRAWING IS UNPUBLISHED. RELEASED FOR PUBLICATION  
 COPYRIGHT copyright.dBTe- ALL RIGHTS RESERVED.

REVISIONS					
P	LTR	DESCRIPTION	DATE	DWN	APVD
Z36		REVISED PER ECR-19-008179	26JUN2019	MG	DC
Z37		ECR-19-013042	20AUG2019	KD	FL
Z38		ECR-20-003236	09MAR2020	DC	FL
Z39		ECR-21-103265	19MAY2021	SM	FL

RAPPRESENTAZIONE GRAFICA DEI P/Ns:  
 (GRAPHICAL REPRESENTATION OF P/Ns):  
 x-282042-1

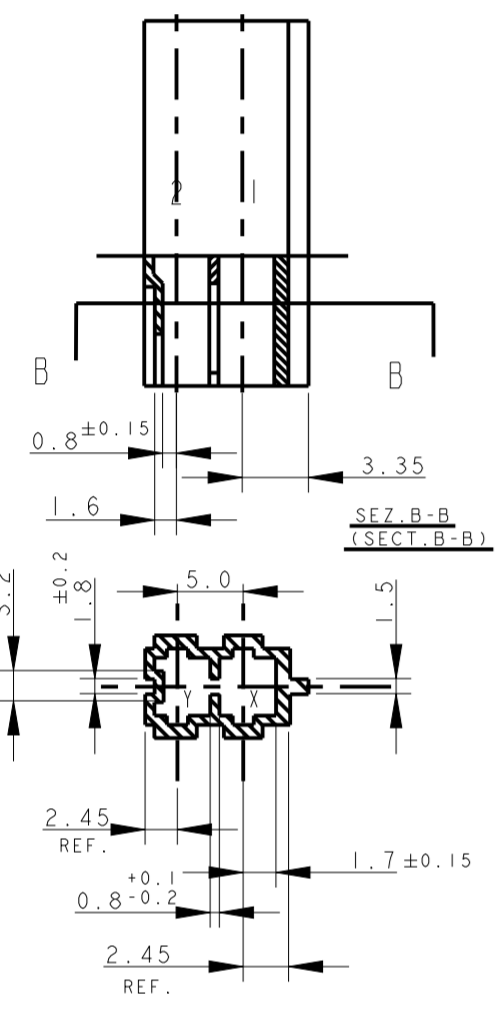

RAPPRESENTAZIONE GRAFICA DEI P/Ns:  
 (GRAPHICAL REPRESENTATION OF P/Ns):  
 x-282042-2

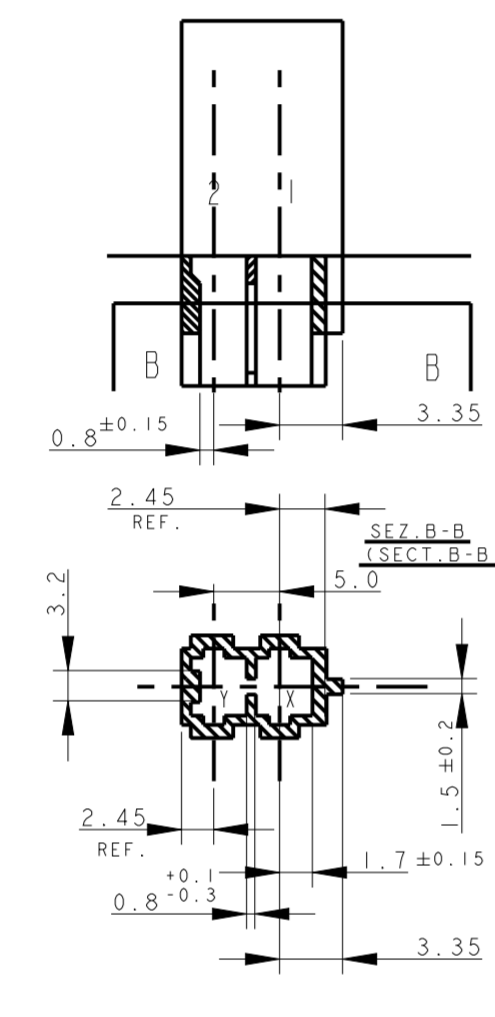

RAPPRESENTAZIONE GRAFICA DEI P/Ns:  
 (GRAPHICAL REPRESENTATION OF P/Ns):  
 x-282042-3 & 0-2293372-2  
 & x-2298752-2

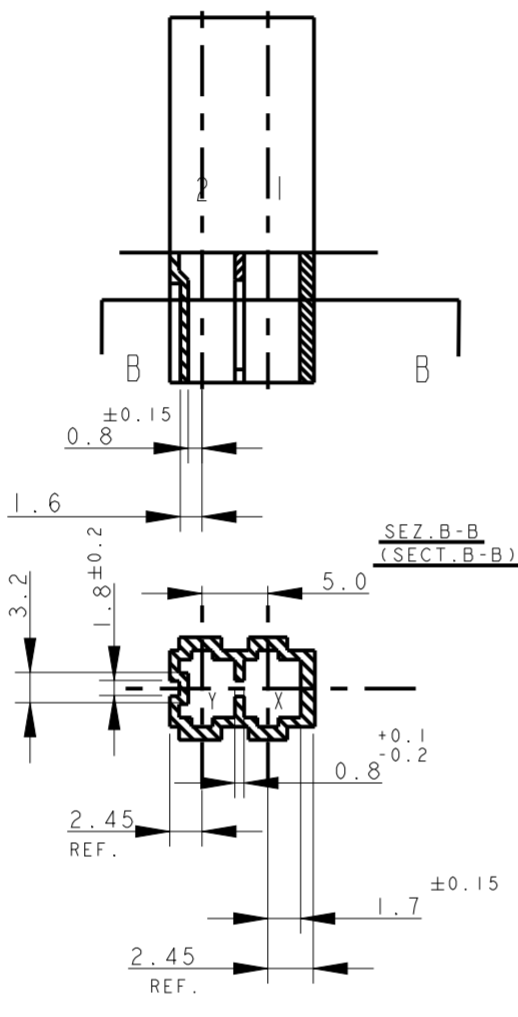

DETAILS FOR x-284561-2

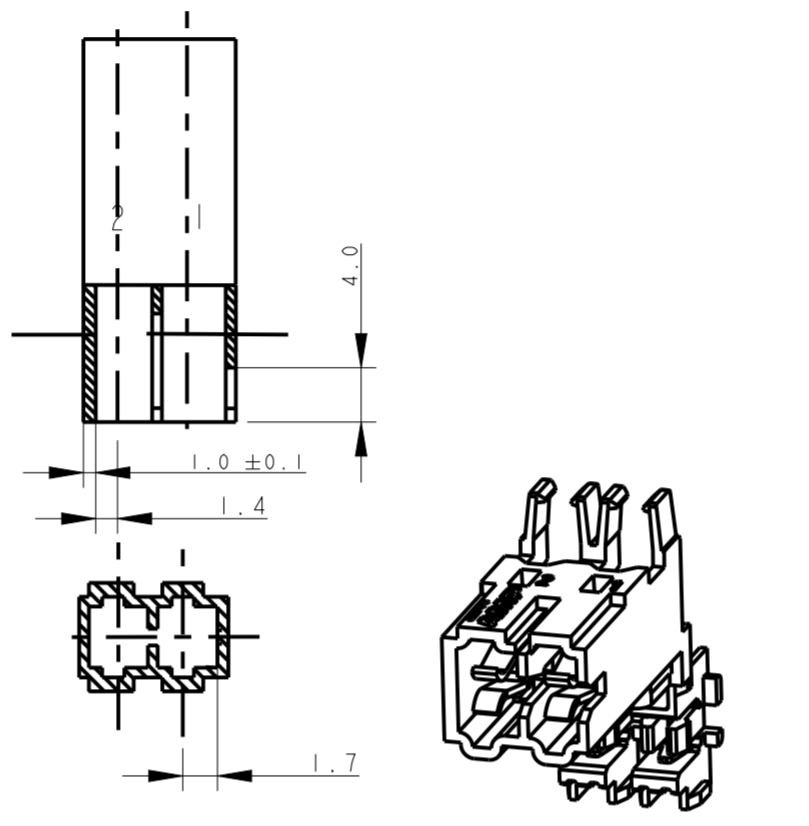

RAPPRESENTAZIONE GRAFICA DEI P/Ns:  
 (GRAPHICAL REPRESENTATION OF P/Ns):  
 x-284561-1

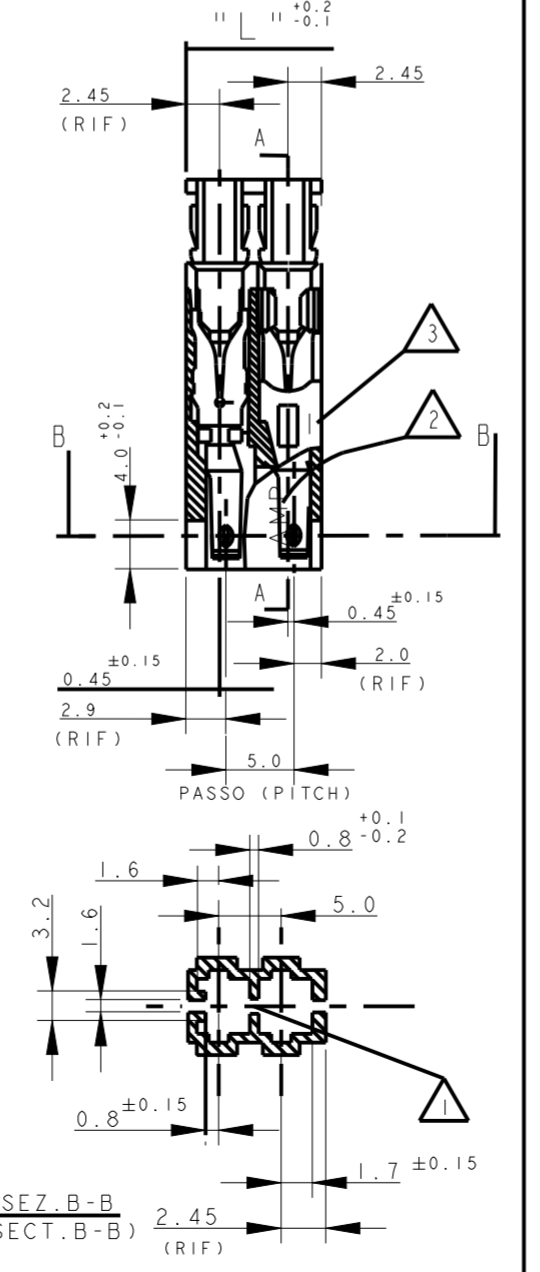

RAPPRESENTAZIONE GRAFICA DEI P/Ns:  
 (GRAPHICAL REPRESENTATION OF P/Ns):  
 1-2293372-2

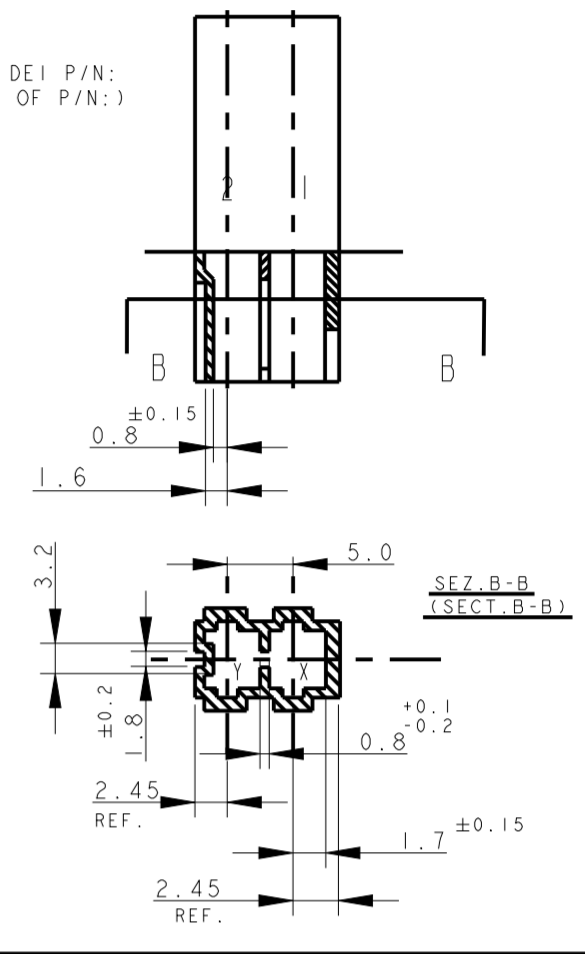

RAPPRESENTAZIONE GRAFICA DEI P/Ns:  
 (GRAPHICAL REPRESENTATION OF P/Ns):  
 x-282042-4

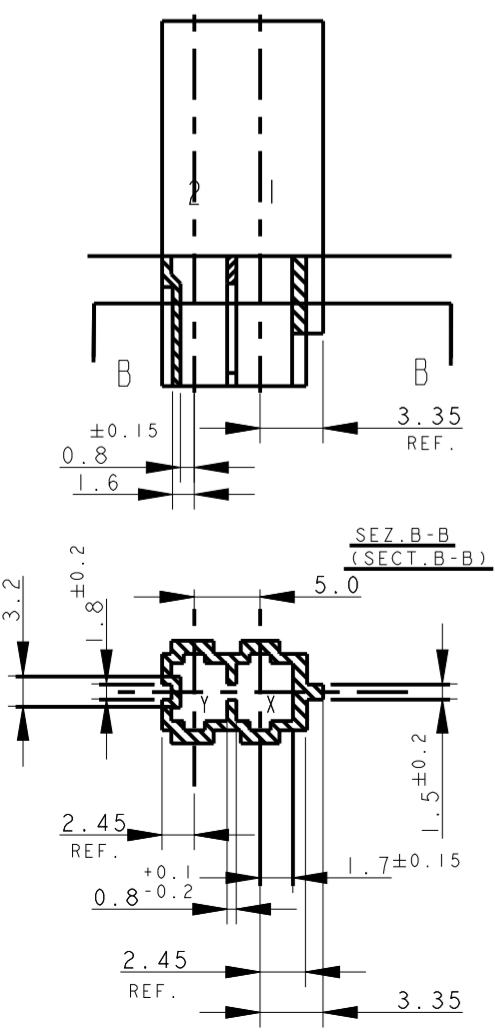

RAPPRESENTAZIONE GRAFICA DEI P/Ns:  
 (GRAPHICAL REPRESENTATION OF P/Ns):  
 x-282042-5

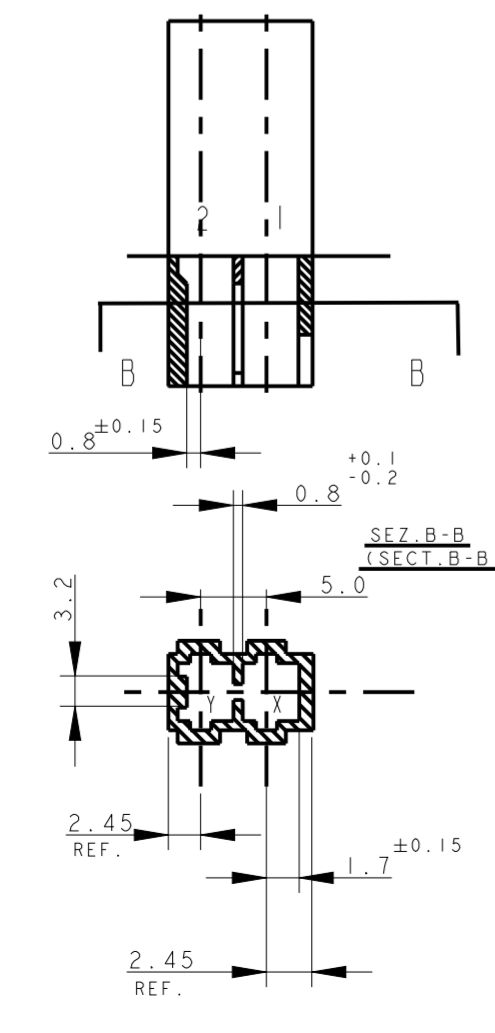

RAPPRESENTAZIONE GRAFICA DEI P/Ns:  
 (GRAPHICAL REPRESENTATION OF P/Ns):  
 x-282042-6

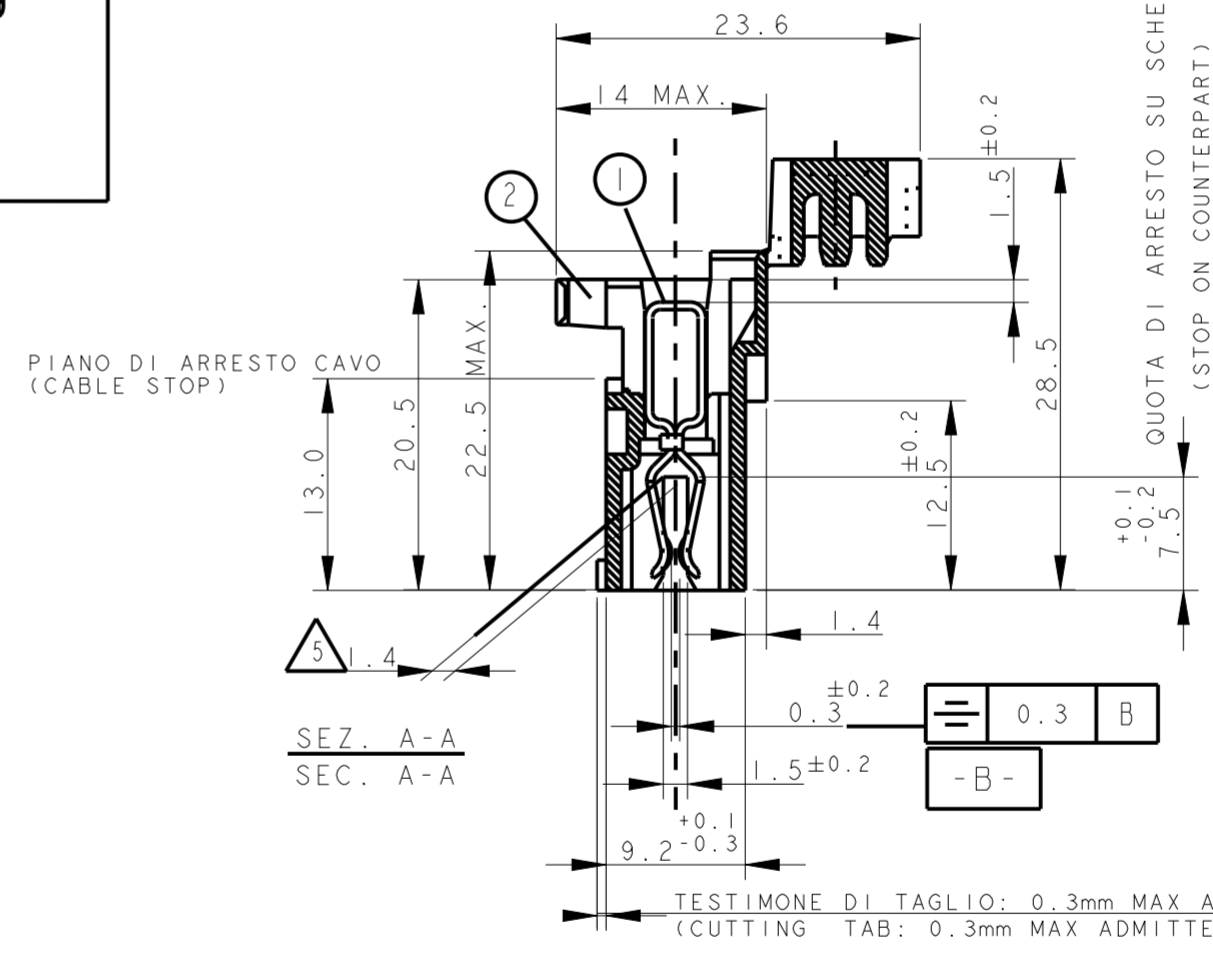
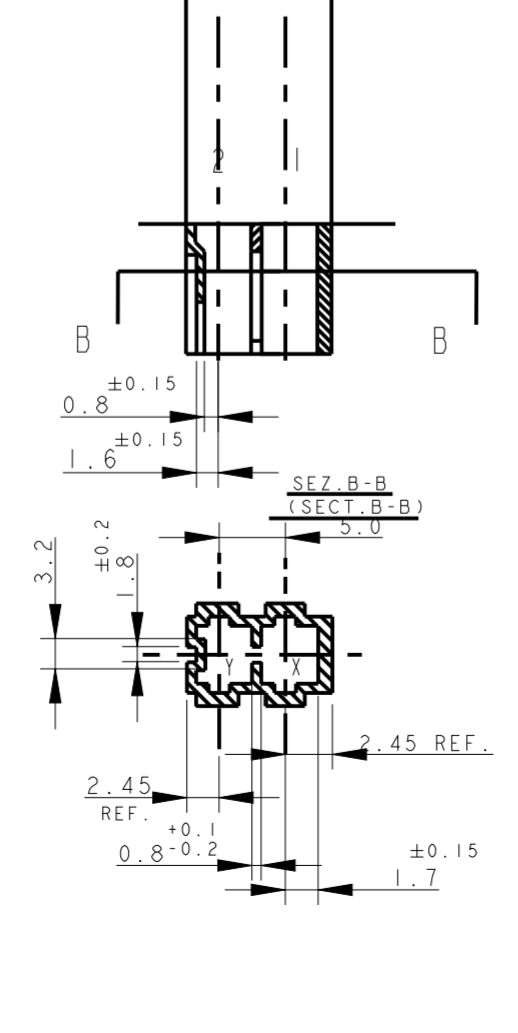

PN NOT YET RELEASED FOR PRODUCTION

7) SEE FURTHER SHEETS FOR PN TABLES

10) PER LE DIMENSIONI DELLE DIME DEL CIRCUITO STAMPATO VEDERE FOGLIO 5 E 6  
 (FOR PCB LAYOUT AND DIMENSIONS SEE SHEET 5 AND 6)

DIAM. ISOLANTE  
 (INS. DIA. RANGE)  
 2.6 - 2.8  
 RANGO FILO  
 (WIRE RANGE)  
 0.5-0.75

THIS DRAWING IS A CONTROLLED DOCUMENT.		DWN C. CORDOLA 23JUL1996
DIMENSIONS: mm		CHK G. TURCO 23JUL1996
TOLERANCES UNLESS OTHERWISE SPECIFIED:		APVD G. TURCO 23JUL1996
0 PLC ± 0.3	1 PLC ± 0.3	PRODUCT SPEC 108-20067
2 PLC ± 0.3	3 PLC ± 0.3	APPLICATION SPEC 114-20018
4 PLC ± 0.3	ANGLES ± 2°	FINISH STAGNATO (TIN PLATED)
MATERIAL CONNETTORE NYLON (CONNECTOR NYLON) CONTATTO OTTONE (CONTACT BRASS)		WEIGHT -

TE Connectivity		NAME MONO-SHAPE, MK1 PCB CONNECTOR 2-12 POS.	
		SIZE A2	CAGE CODE 1
DRAWING NO C-282042		RESTRICTED TO	
SCALE 2:1		SHEET OF 11	
CUSTOMER DRAWING		REV 739	

THIS DRAWING IS UNPUBLISHED. RELEASED FOR PUBLICATION  
 © COPYRIGHT copyright.d8Te- ALL RIGHTS RESERVED.

REVISIONS				
P	LTR	DESCRIPTION	DATE	DWN APVD
-	-	SEE SHEET 1	-	-

RAPPRESENTAZIONE GRAFICA DEI P/Ns:  
 (GRAPHICAL REPRESENTATION OF P/Ns:)  
 284546-2

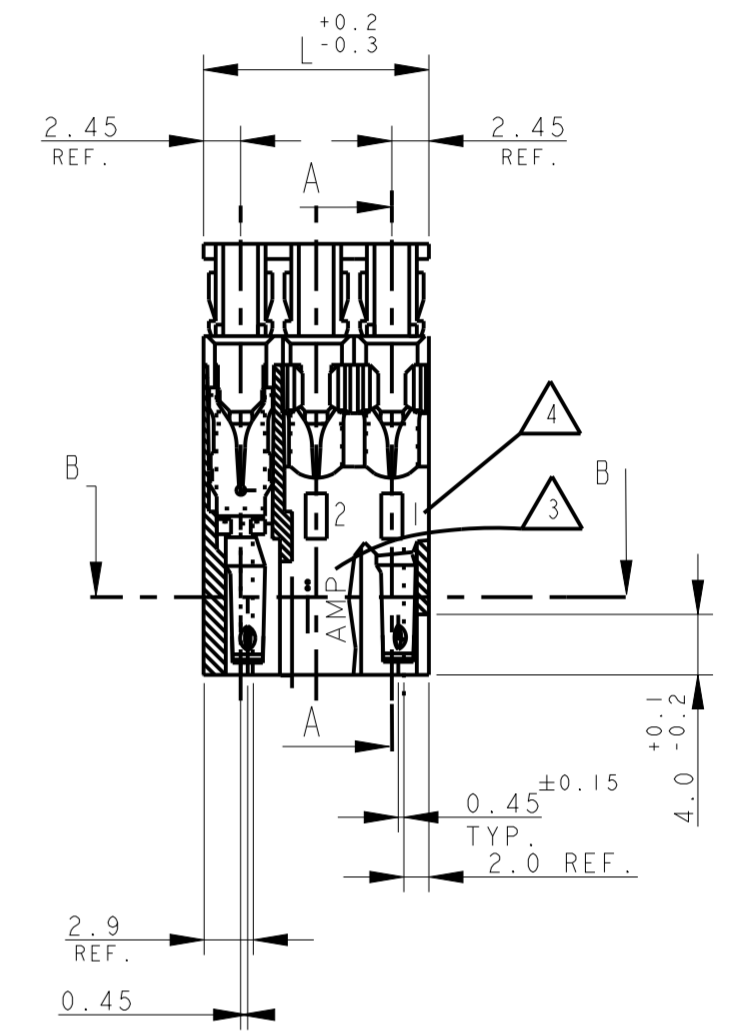
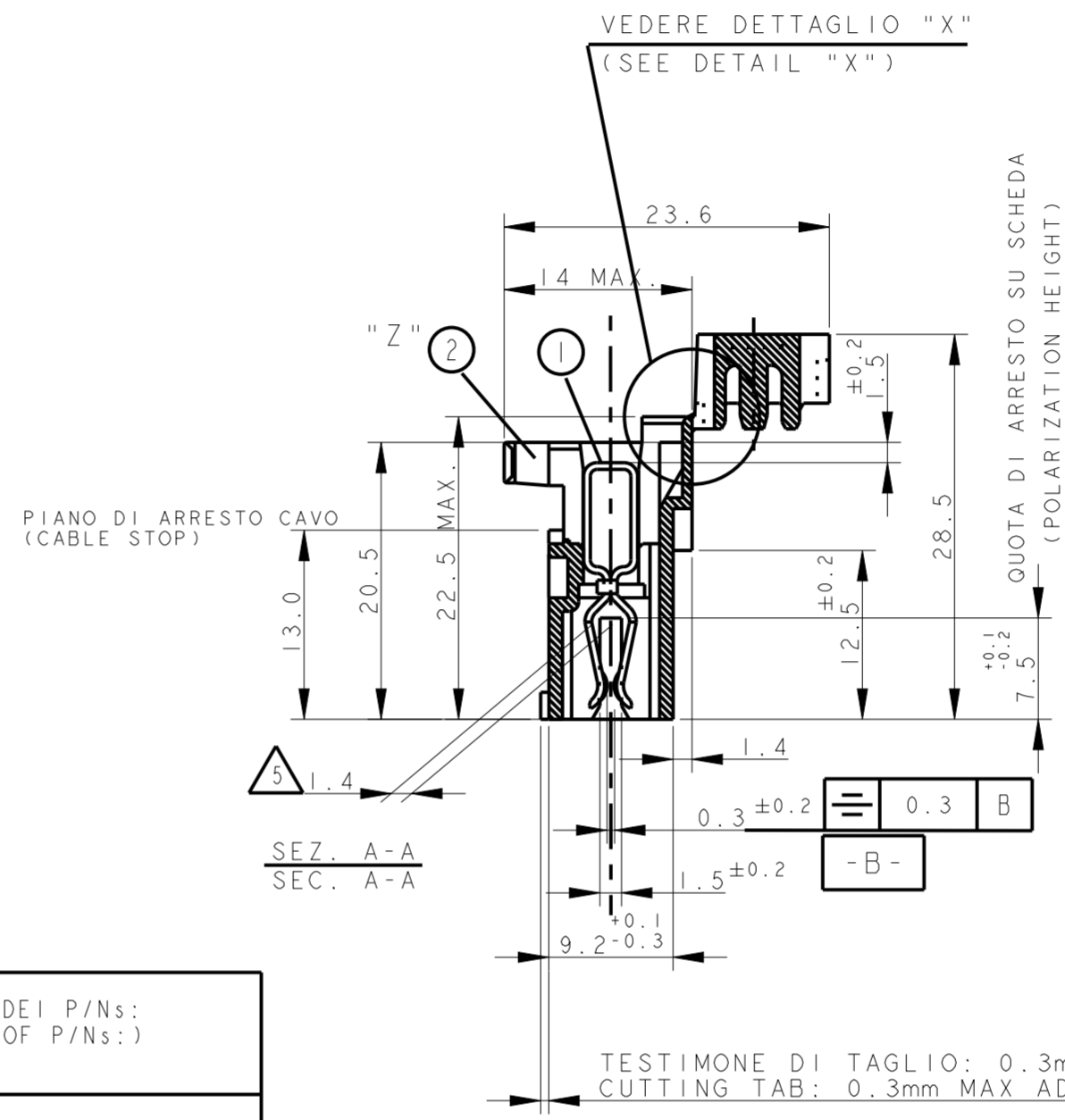
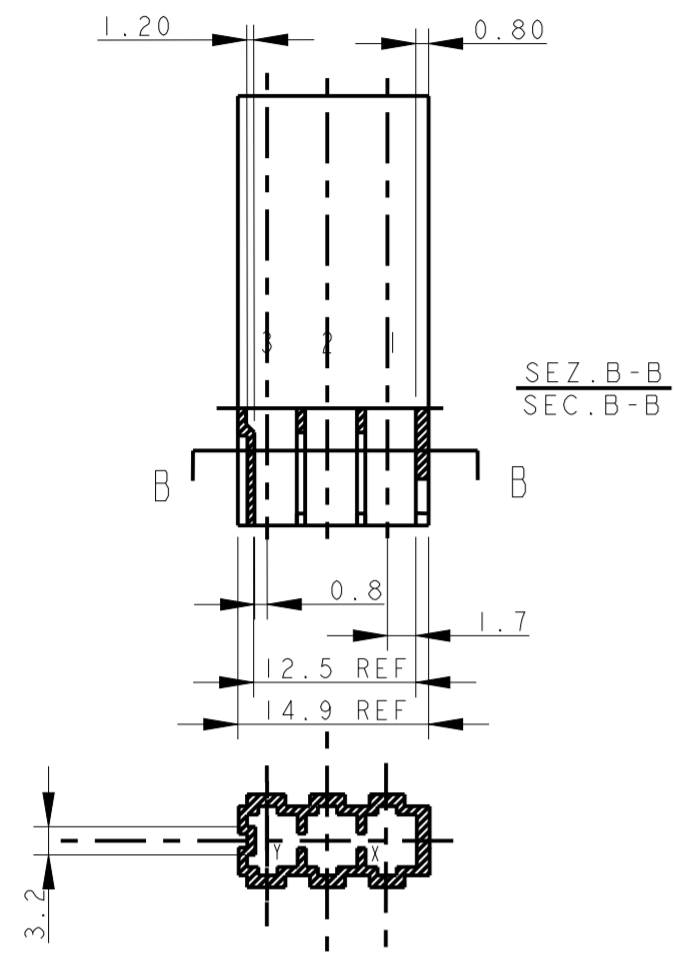

RAPPRESENTAZIONE GRAFICA DEI P/Ns:  
 (GRAPHICAL REPRESENTATION OF P/Ns:)  
 x-282043-2 and x-282043-3

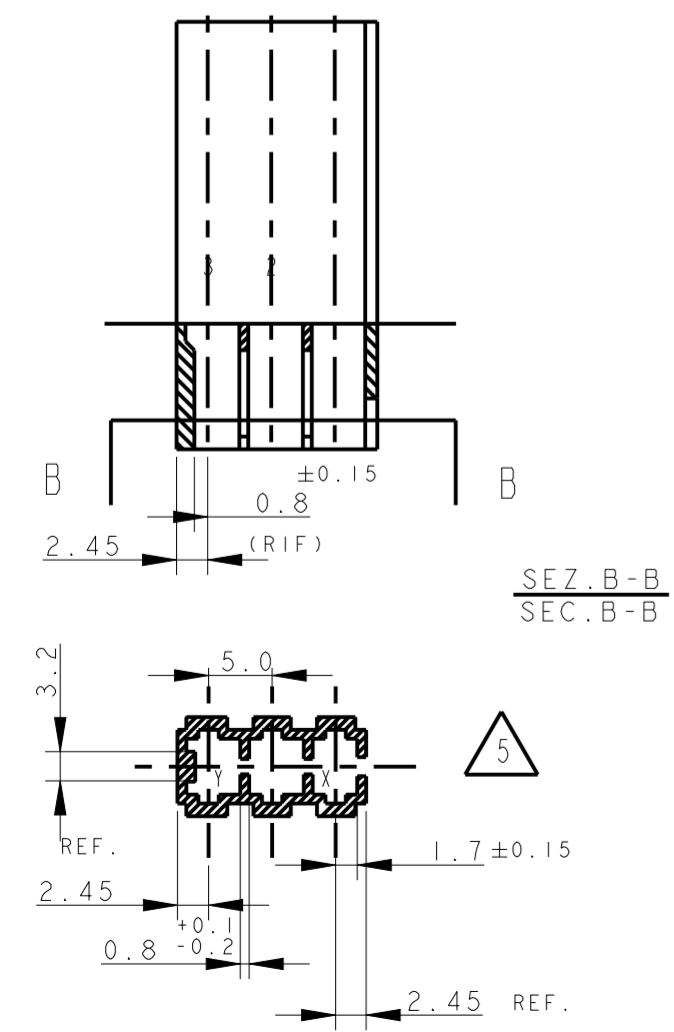

RAPPRESENTAZIONE GRAFICA DEI P/Ns:  
 (GRAPHICAL REPRESENTATION OF P/Ns:)  
 x-282235-2 and x-282235-3

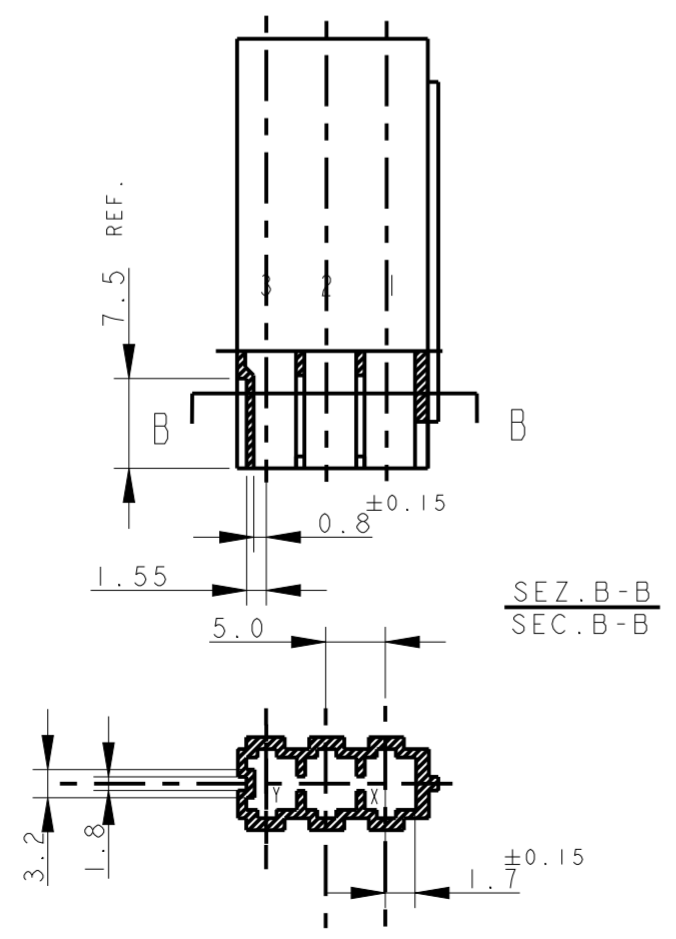

RAPPRESENTAZIONE GRAFICA DEI P/Ns:  
 (GRAPHICAL REPRESENTATION OF P/Ns:)  
 x-284546-1

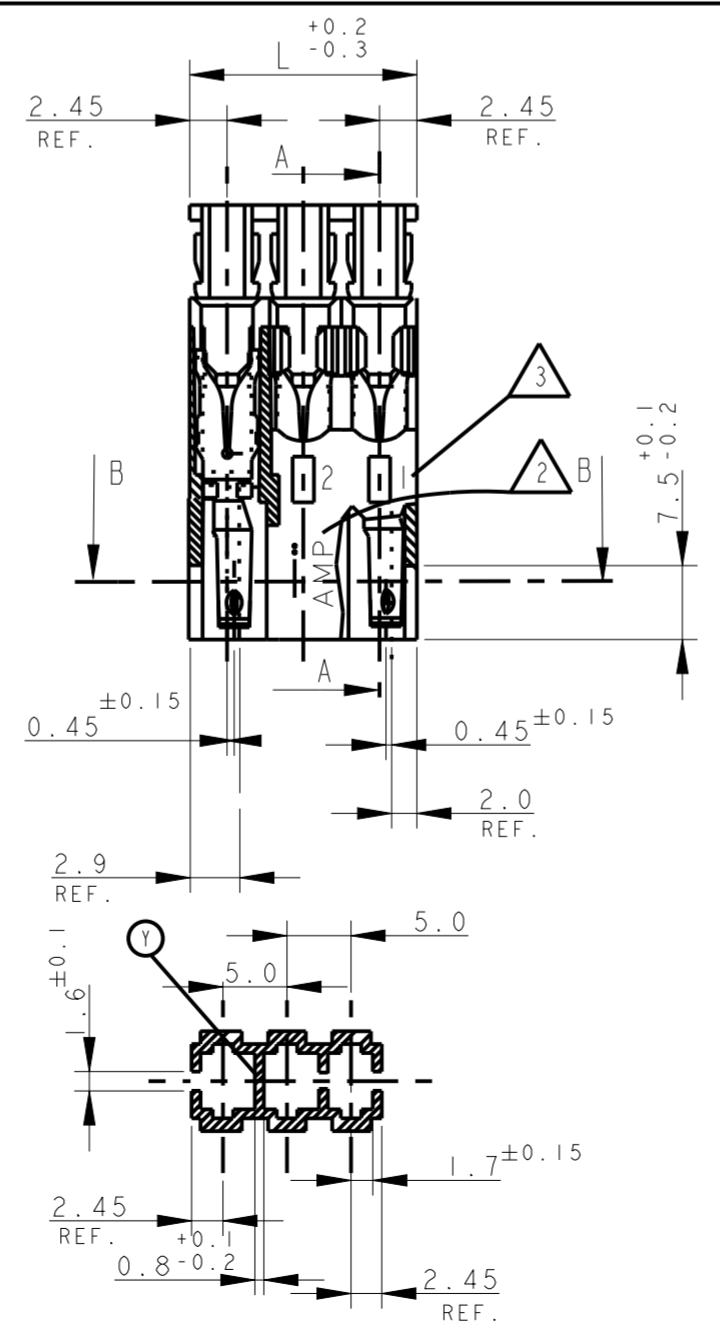

USCITA CAVI IN ALTO  
 (CABLE EXIT IS UP)

7) SEE FURTHER SHEETS FOR PN TABLES

10) PER LE DIMENSIONI DELLE DIME DEL CIRCUITO STAMPATO  
 VEDERE FOGLIO 5 E 6  
 (FOR PCB LAYOUT AND DIMENSIONS SEE SHEET 5 AND 6)

THIS DRAWING IS A CONTROLLED DOCUMENT.		DWN C. CORDOLA 23 JUL 1996	 TE Connectivity	NAME MONO-SHAPE, MK1 PCB CONNECTOR 2-12 POS.	
DIMENSIONS: mm		CHK G. TURCO 23 JUL 1996		PRODUCT SPEC 108-20067	
TOLERANCES UNLESS OTHERWISE SPECIFIED: 0 PLC ±0.3 1 PLC ±0.3 2 PLC ±0.3 3 PLC ±0.3 4 PLC ±0.3 ANGLES ±2°		APVD G. TURCO 23 JUL 1996		APPLICATION SPEC 114-20018	
MATERIAL CONNETTORE NYLON (CONNECTOR NYLON) CONTATTO OTTONE (CONTACT BRASS)		FINISH STAGNATO (TIN PLATED)		WEIGHT -	CUSTOMER DRAWING
SCALE 2:1			SHEET 2 OF 11	REV 739	

THIS DRAWING IS UNPUBLISHED. RELEASED FOR PUBLICATION  
 COPYRIGHT © 1996 dbTe. ALL RIGHTS RESERVED.

REVISIONS				
P	LTR	DESCRIPTION	DATE	DWN APVD
-	-	SEE SHEET 1	-	-

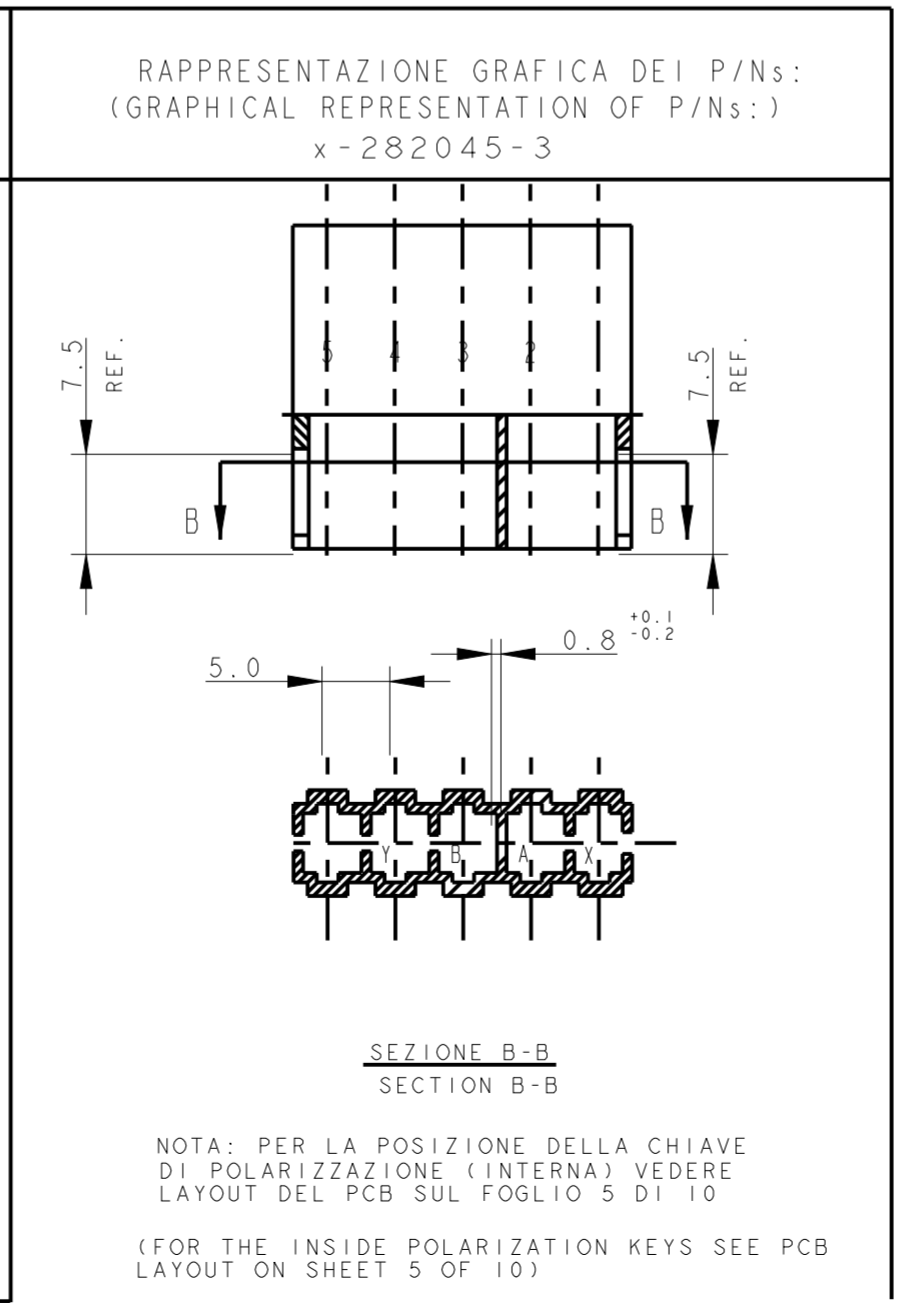
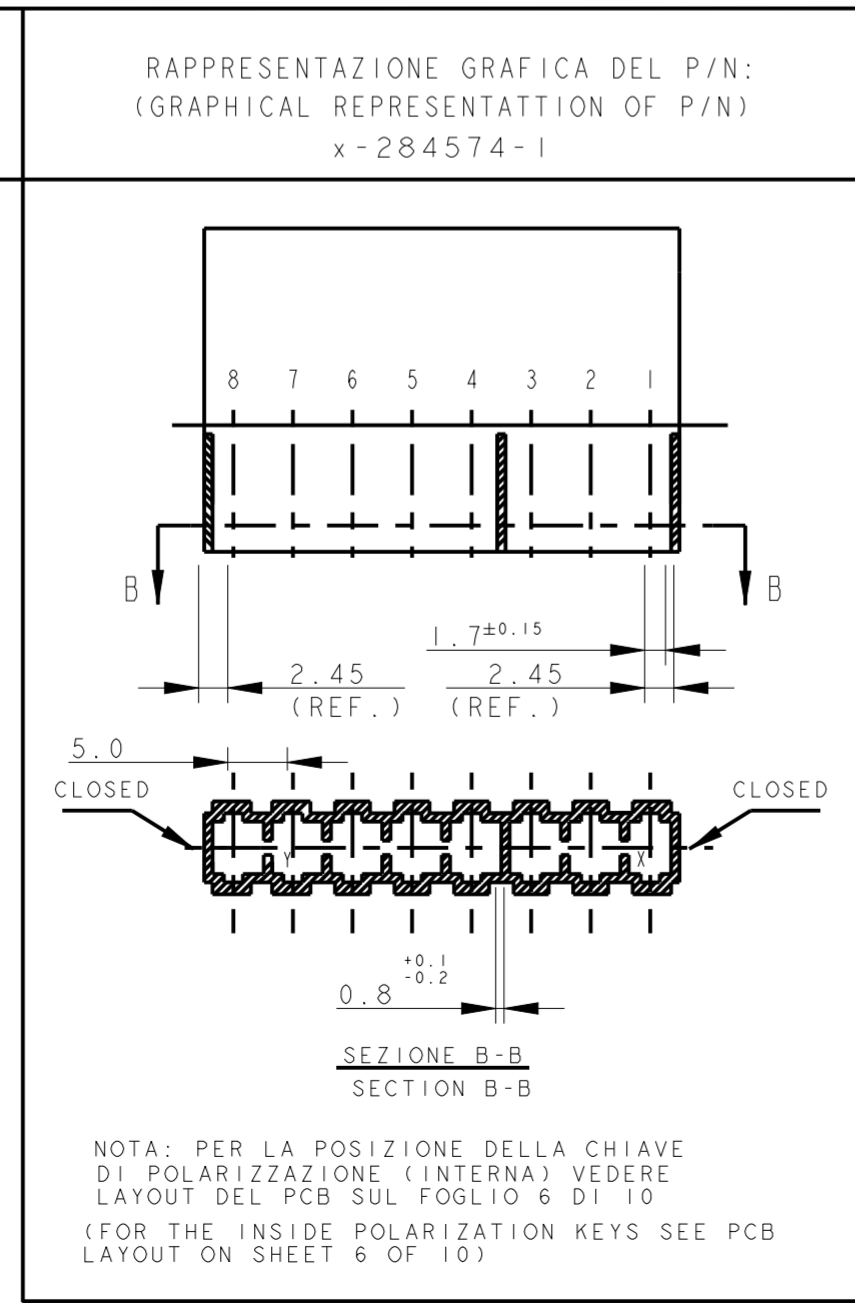
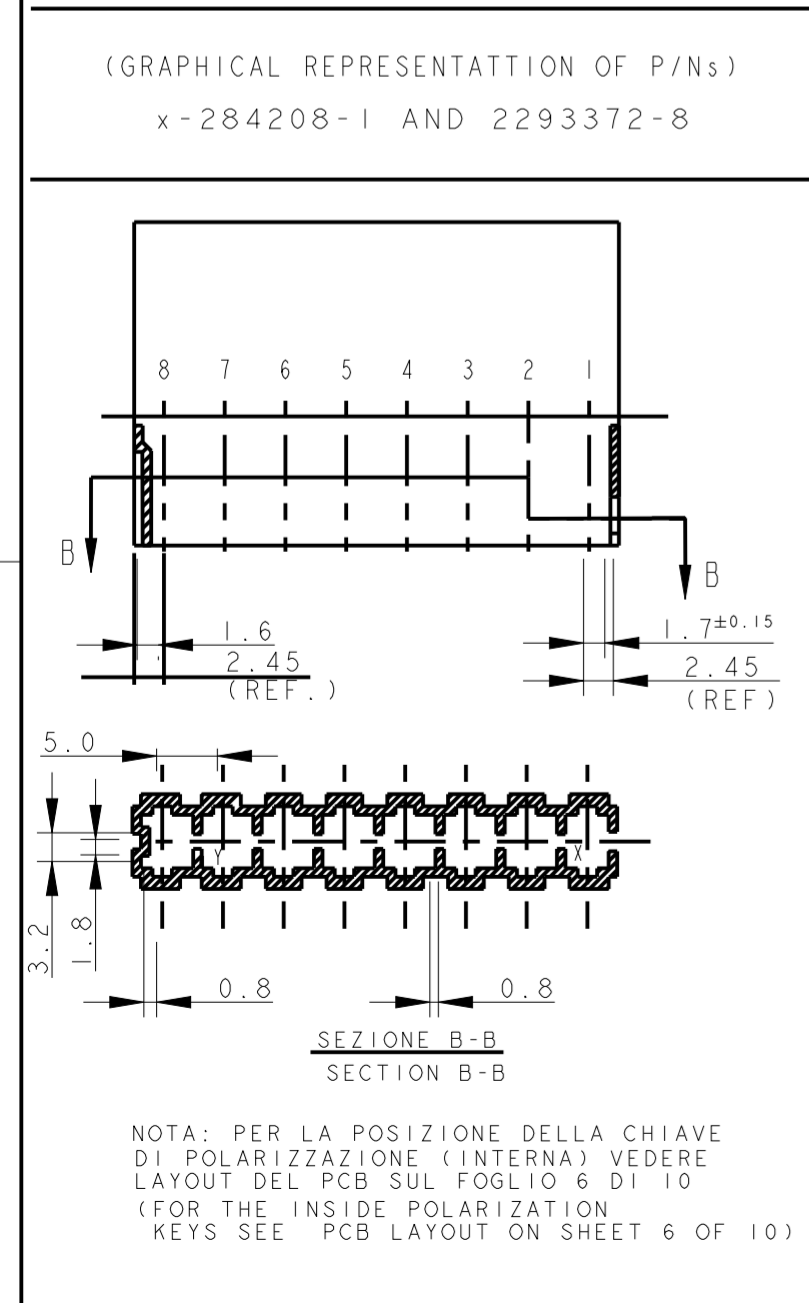
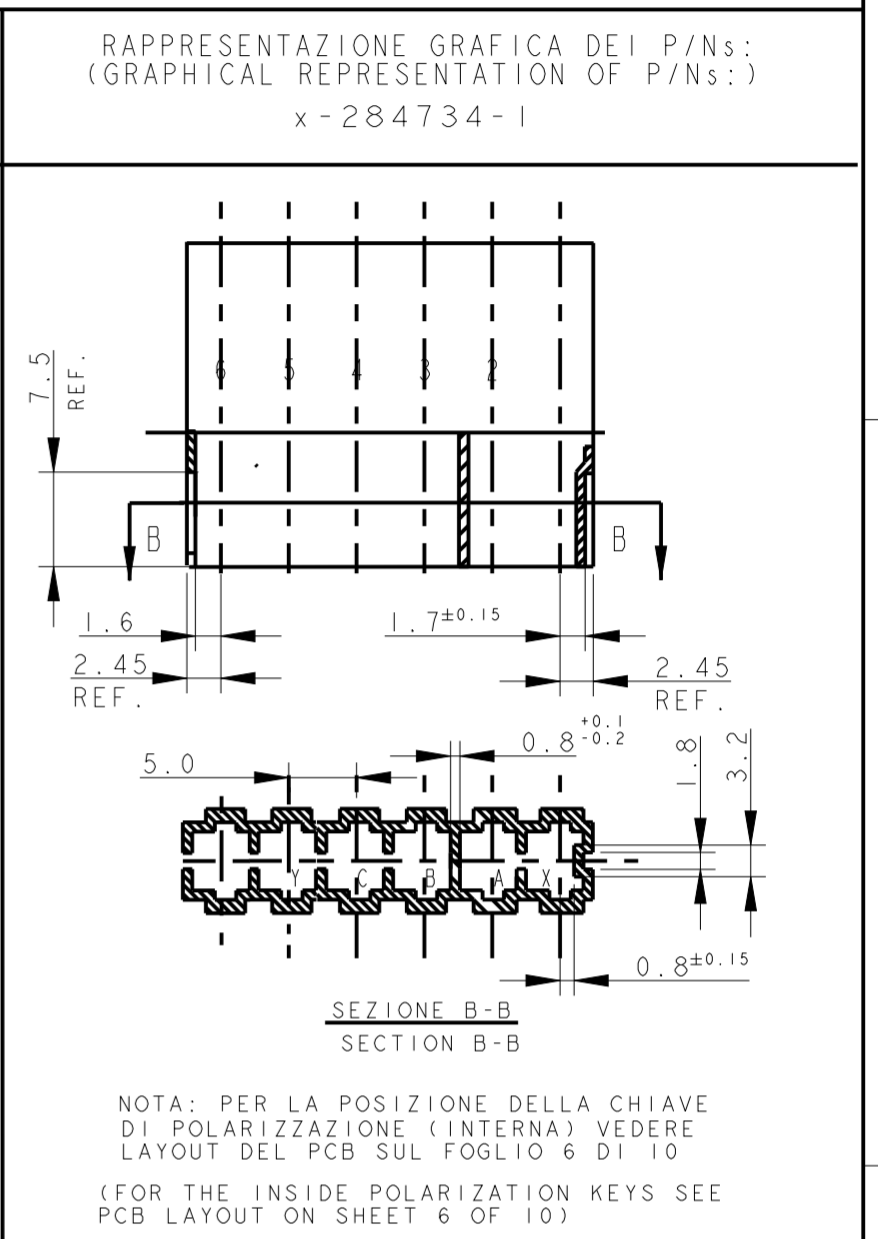
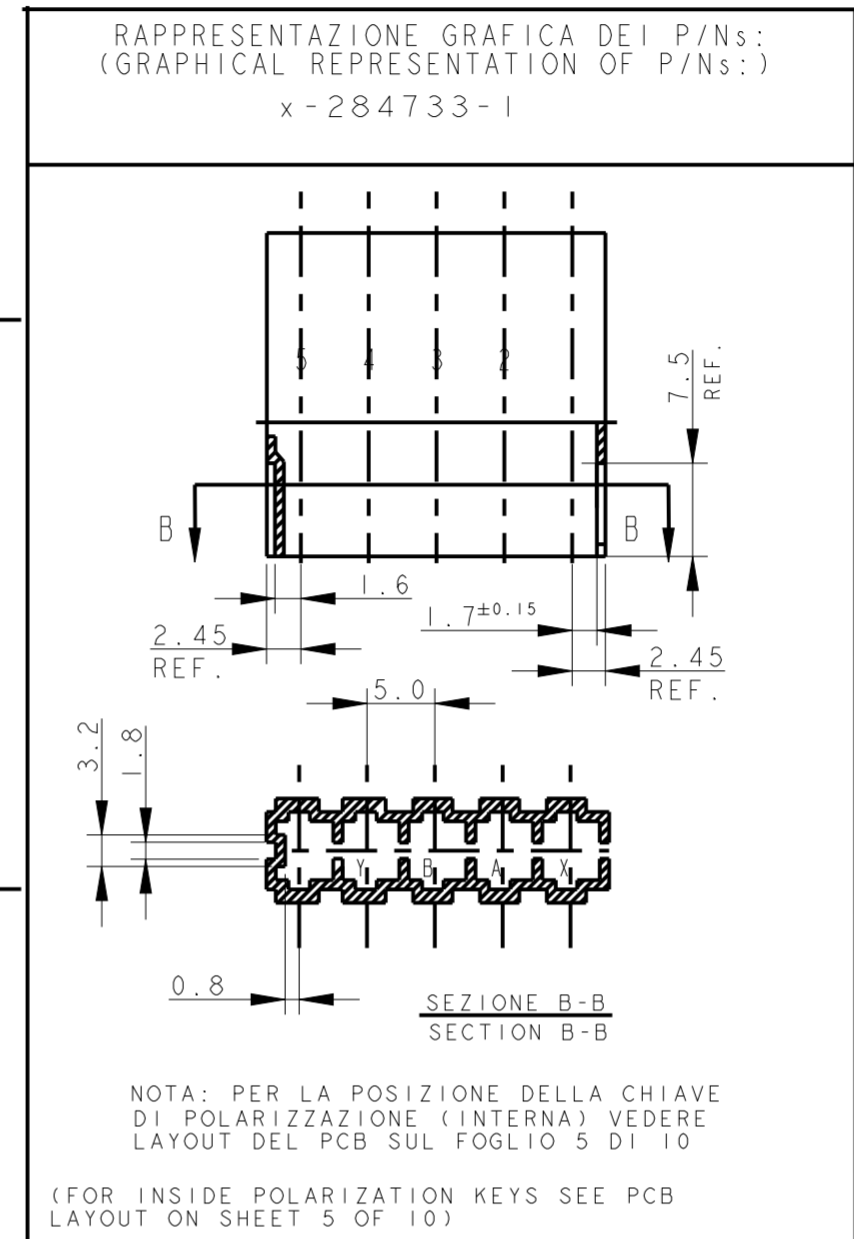
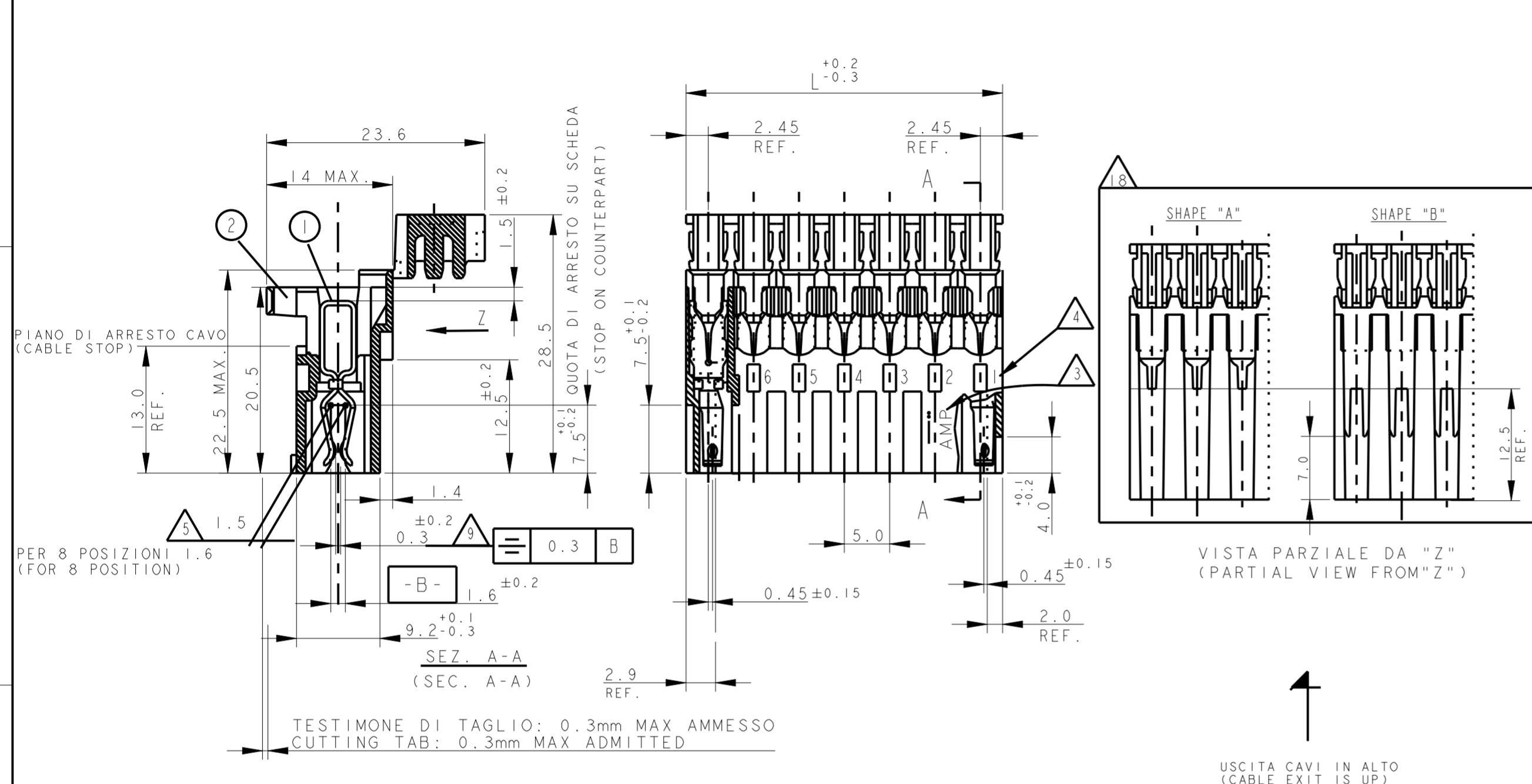

7) SEE FURTHER SHEETS FOR PN TABLE

9) PER 6 - 8 POSIZIONI (FOR 6 - 8 POSITION)

10) PER LE DIMENSIONI DELLE DIME DEL CIRCUITO STAMPATO VEDERE FOGLIO 5 E 6 (FOR PCB LAYOUT AND DIMENSIONS SEE SHEET 5 AND 6)

18) PROFILO "A" E' VALIDO PER OGNI CONFIGURAZIONE, PROFILO "B" E' AMMESSO SOLO PER I PN IDENTIFICATI IN TABELLA DALLA PRESENTE NOTA (SHAPE "A" VALID FOR EACH CONFIGURATION, SHAPE "B" IS PERMITTED ONLY ON PN WHERE THIS NOTE IS SHOWN ON RELEVANT DRAWING TABLE)

3-282045-4  
2293372-5  
2298752-5  
GRAPHICAL REPRESENTATION

POLARIZATION POSITION SEE NOTE

THIS DRAWING IS A CONTROLLED DOCUMENT.		DWN C. CORDOLA 23JUL1996	TE Connectivity
DIMENSIONS: mm		CHK G. TURCO 23JUL1996	
TOLERANCES UNLESS OTHERWISE SPECIFIED:		APVD G. TURCO 23JUL1996	NAME MONO-SHAPE, MK1 PCB CONNECTOR 2-12 POS.
0 PLC ± 0.3 1 PLC ± 0.3 2 PLC ± 0.3 3 PLC ± 0.3 4 PLC ± 0.3		PRODUCT SPEC 108-20067	SIZE A2
ANGLES FINISH STAGNATO (TIN PLATED)		APPLICATION SPEC 114-20018	CAGE CODE 1
MATERIAL CONNETTORE NYLON (CONNECTOR NYLON) CONTATTO OTTONE (CONTACT BRASS)		WEIGHT -	DRAWING NO C-282042
		CUSTOMER DRAWING	RESTRICTED TO
		SCALE -	SHEET 3 OF 11
			REV 739

THIS DRAWING IS UNPUBLISHED. RELEASED FOR PUBLICATION  
 © COPYRIGHT copyright.d8Te- ALL RIGHTS RESERVED.

REVISIONS				
P	LTR	DESCRIPTION	DATE	APVD
-	-	SEE SHEET 1	-	-

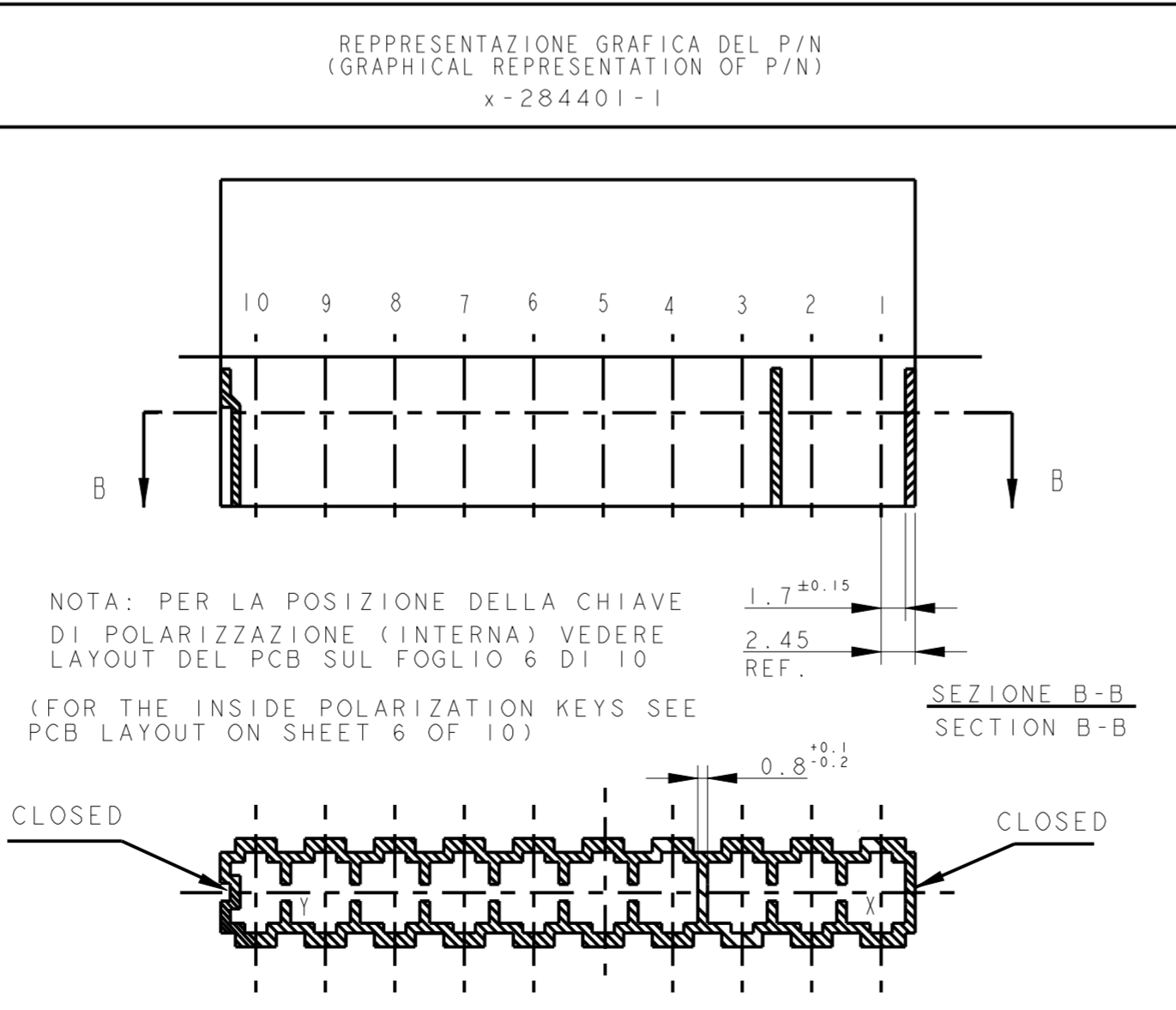
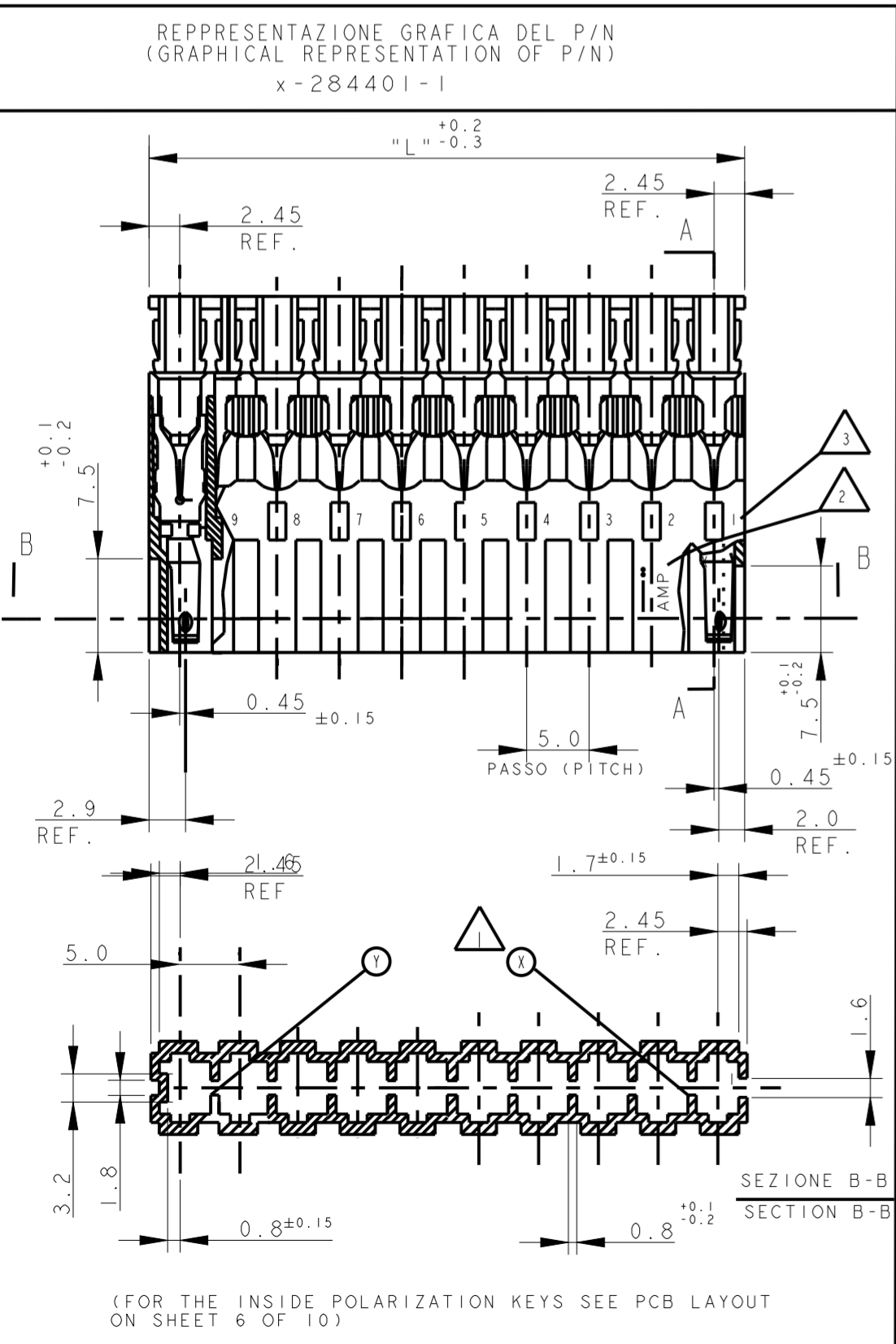
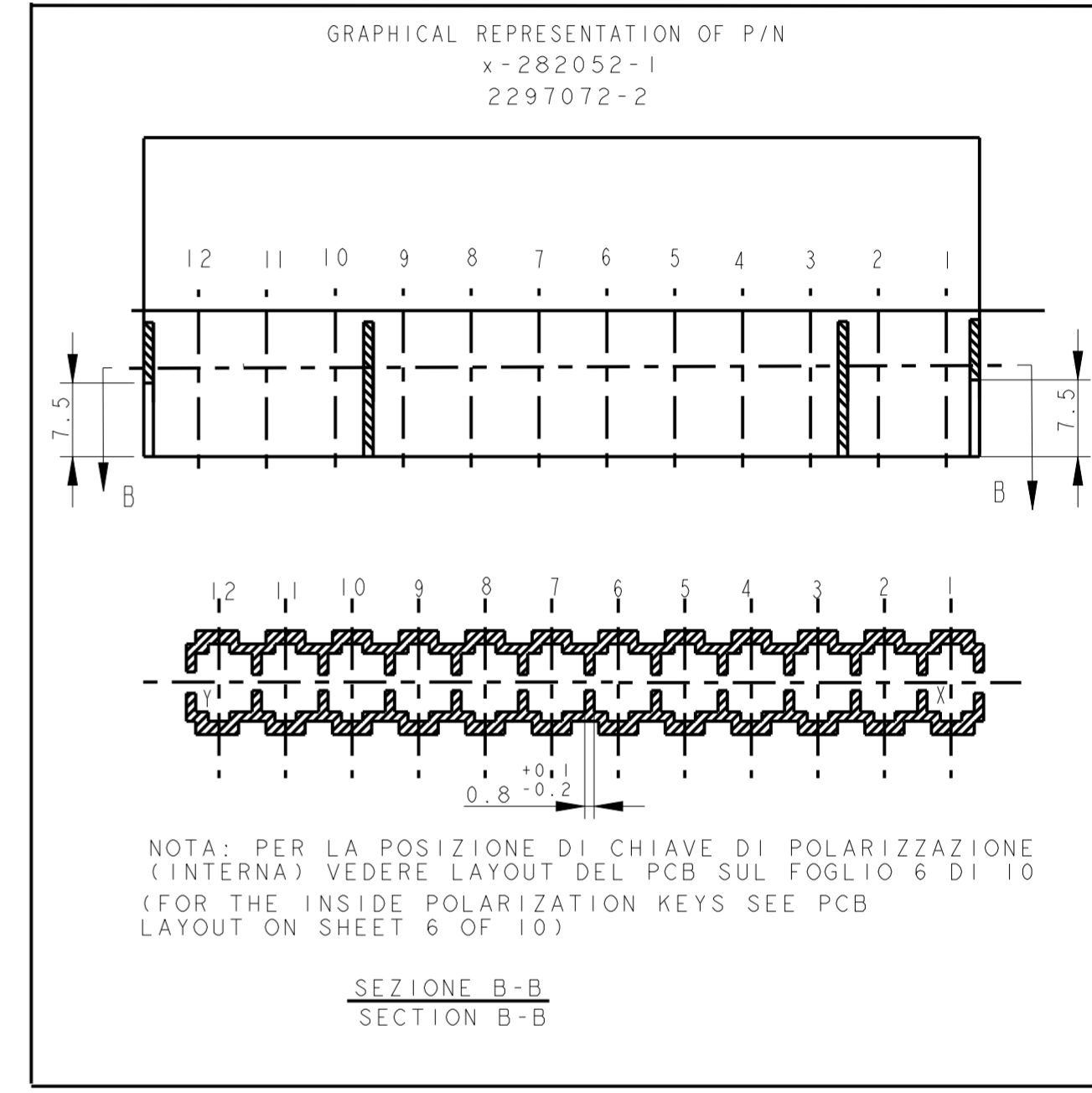
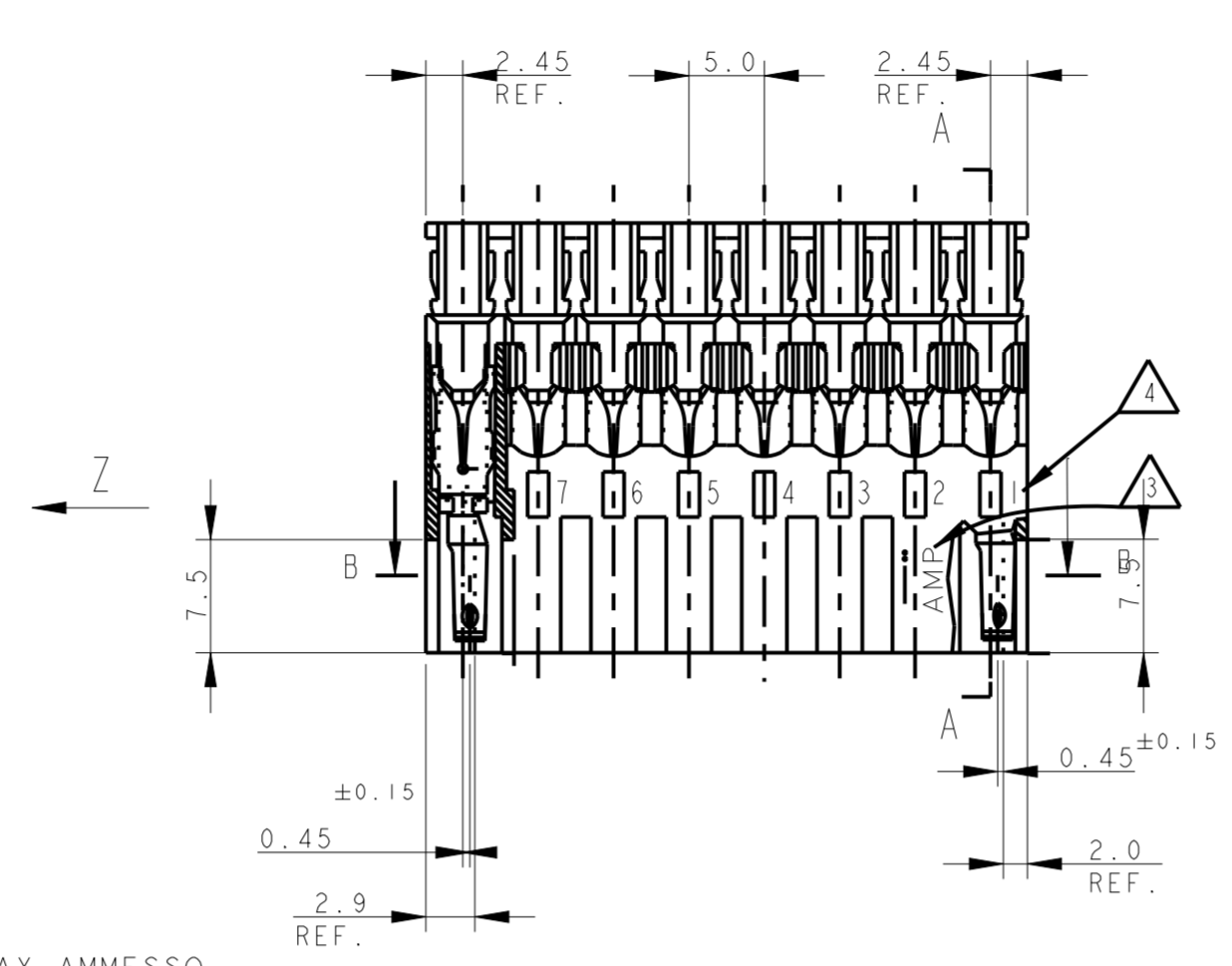
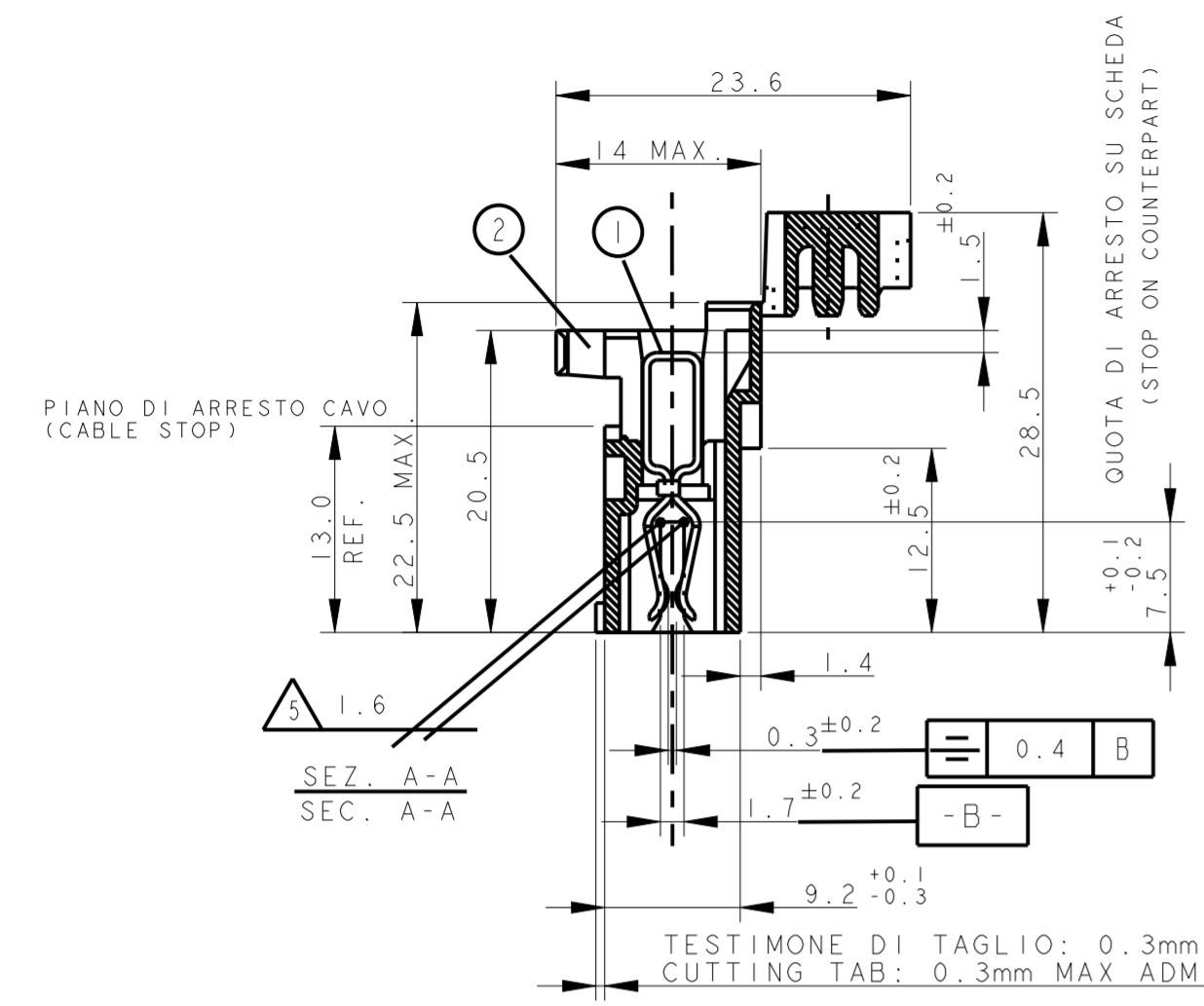

7) SEE FURTHER SHEETS FOR PN TABLES  
 10) PER LE DIMENSIONI DELLE DIME DEL CIRCUITO STAMPATO VEDERE FOGLIO 5 E 6 (FOR PCB LAYOUT AND DIMENSIONS SEE SHEET 5 AND 6)

THIS DRAWING IS A CONTROLLED DOCUMENT.		DWN C. CORDOLA 23JUL1996	TE Connectivity
DIMENSIONS: mm		CHK G. TURCO 23JUL1996	
TOLERANCES UNLESS OTHERWISE SPECIFIED:		APVD G. TURCO 23JUL1996	NAME MONO-SHAPE, MK1 PCB CONNECTOR 2-12 POS.
0 PLC ±0.3		PRODUCT SPEC 108-20067	SIZE A2
1 PLC ±0.3		APPLICATION SPEC 114-20018	CAGE CODE 1
2 PLC ±0.3		WEIGHT -	DRAWING NO G-282042
3 PLC ±0.3		CUSTOMER DRAWING	RESTRICTED TO
4 PLC ±0.3		SCALE -	SHEET 4 OF 11
ANGLES ±2°			REV 739
FINISH STAGNATO (TIN PLATED)			

THIS DRAWING IS UNPUBLISHED. RELEASED FOR PUBLICATION  
 © COPYRIGHT copyright.d8Te- ALL RIGHTS RESERVED.

REVISIONS			
P	LTR	DESCRIPTION	DATE
		SEE SHEET 1	

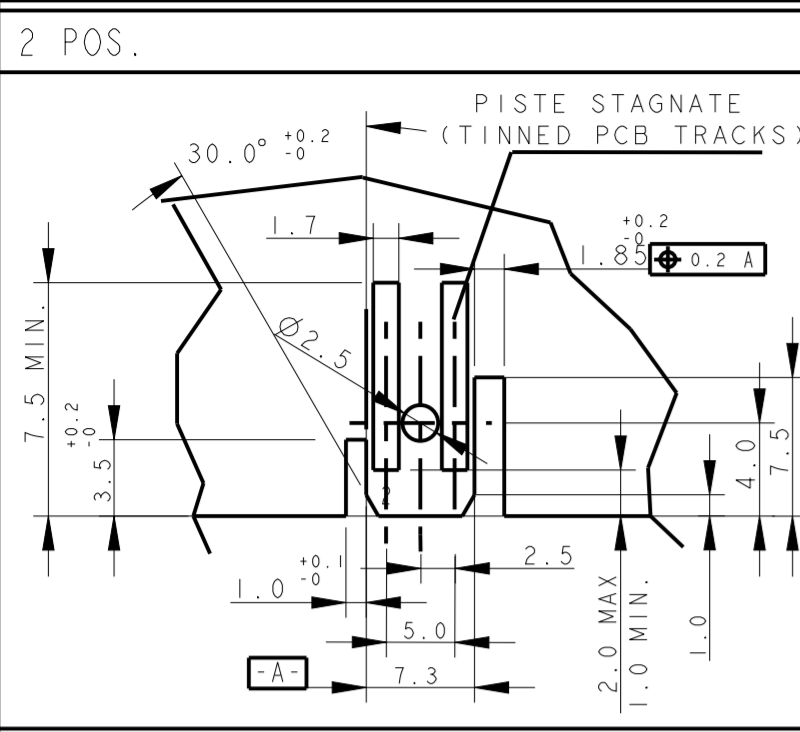

DIMA DEL PCB PER PN (PCB LAYOUT FOR PN.S)  
x-282042-1

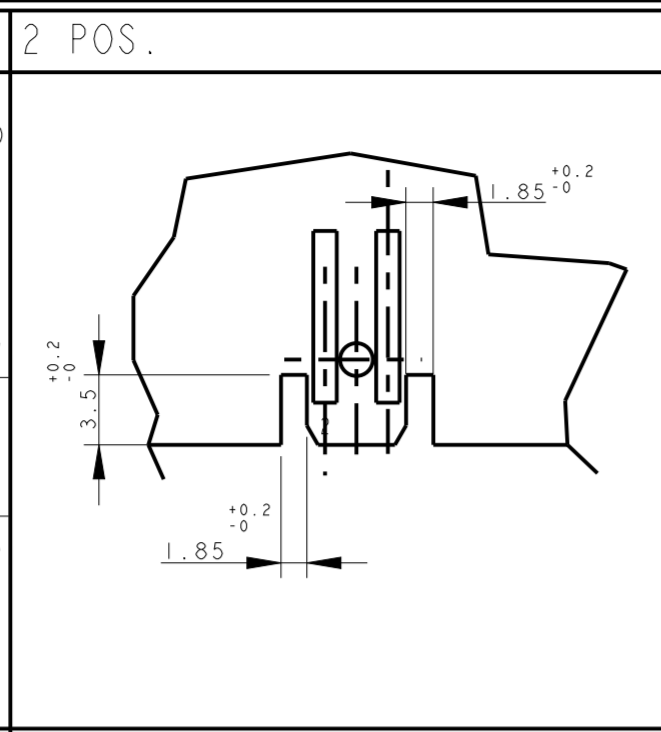

DIMA DEL PCB PER PN (PCB LAYOUT FOR PN.S)  
x-282042-2

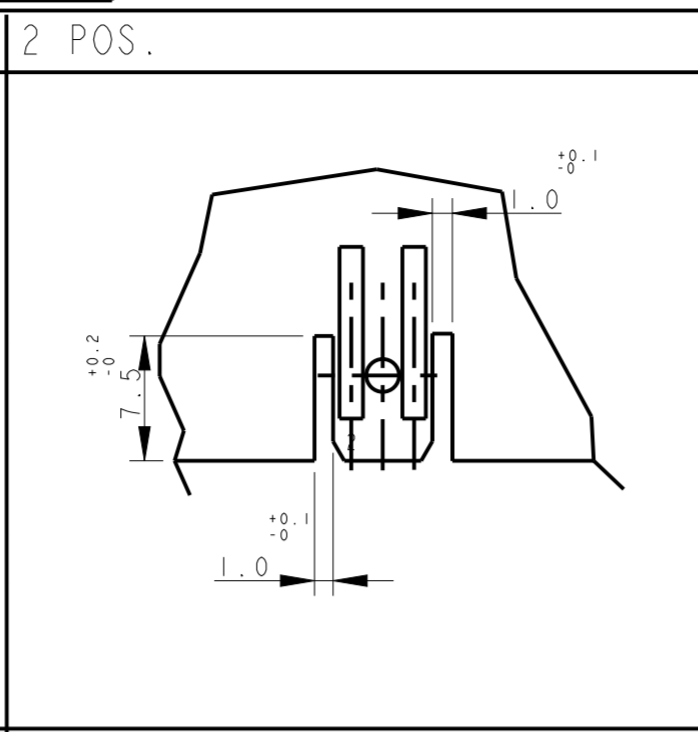

DIMA DEL PCB PER PN (PCB LAYOUT FOR PN.S)  
x-282042-3, 2298752-2 and 2333039-2

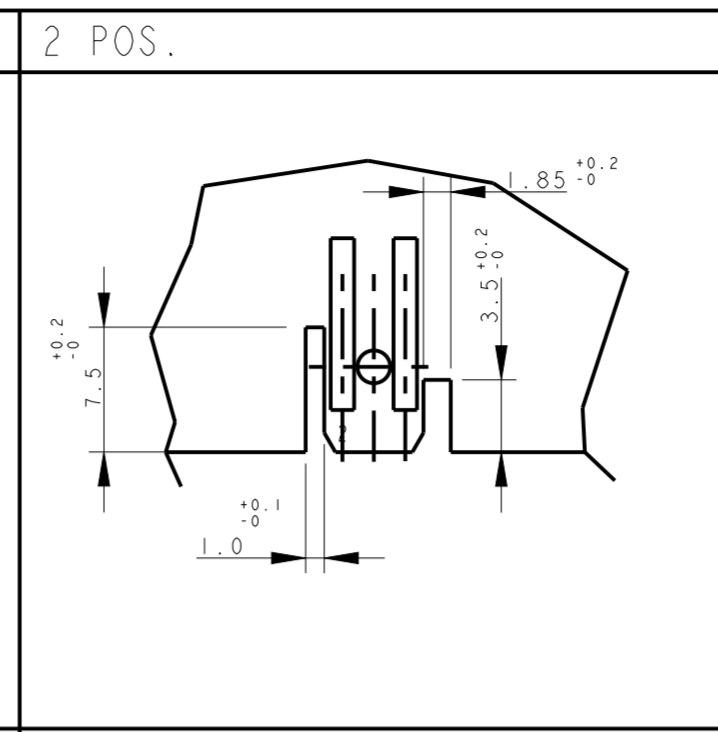

DIMA DEL PCB PER PN (PCB LAYOUT FOR PN.S)  
x-282042-4

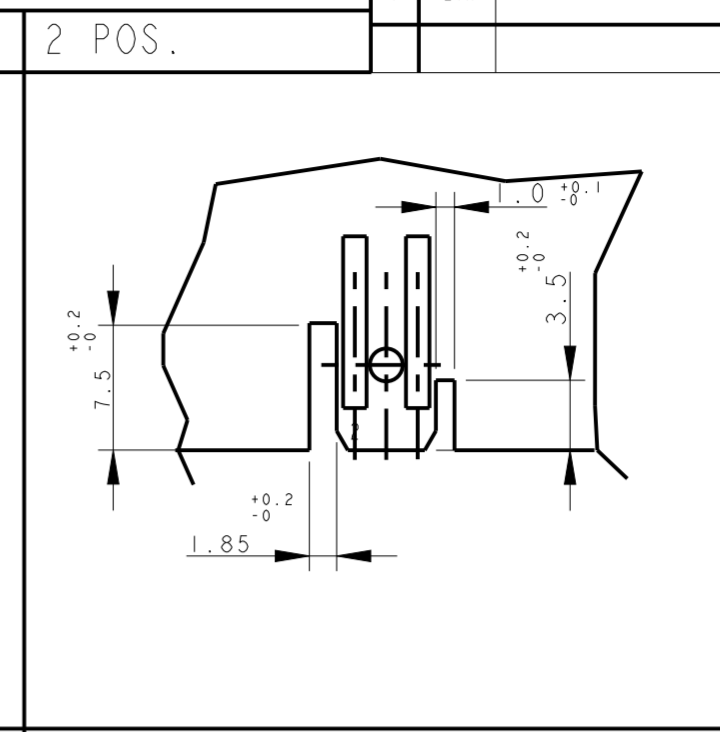

DIMA DEL PCB PER PN (PCB LAYOUT FOR PN.S)  
x-282042-5, 1-2298752-2 and 1-2333039-2

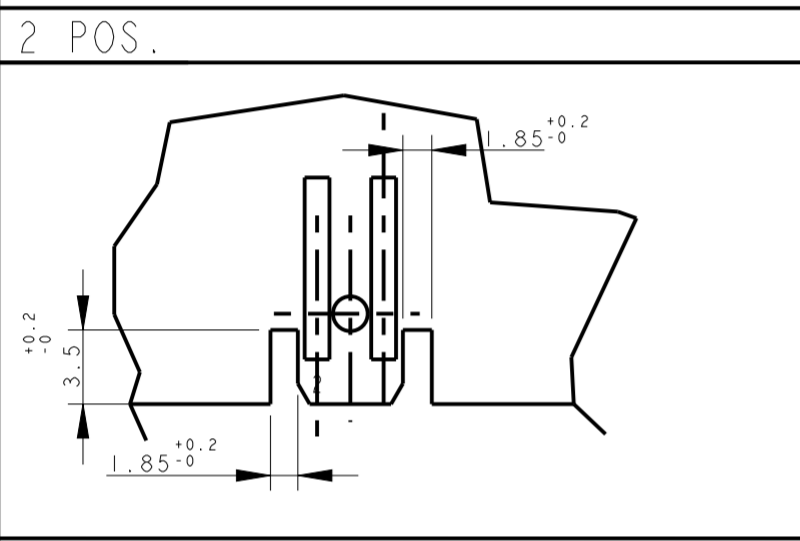
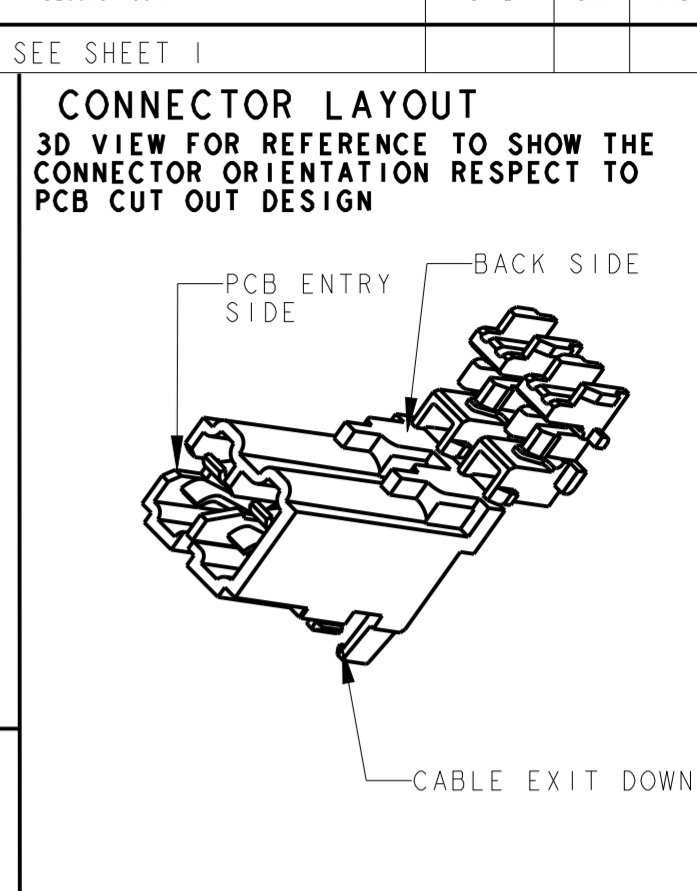

DIMA DEL PCB PER PN (PCB LAYOUT FOR PN.S)  
x-284561-1

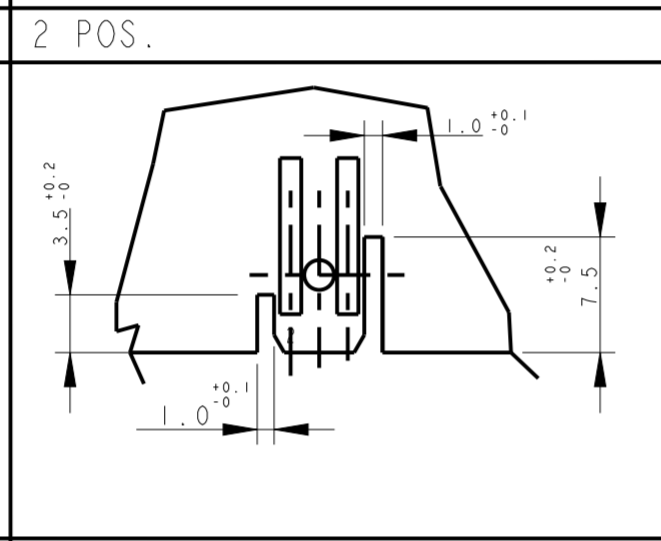

DIMA DEL PCB PER PN (PCB LAYOUT FOR PN.S)  
x-282042-6

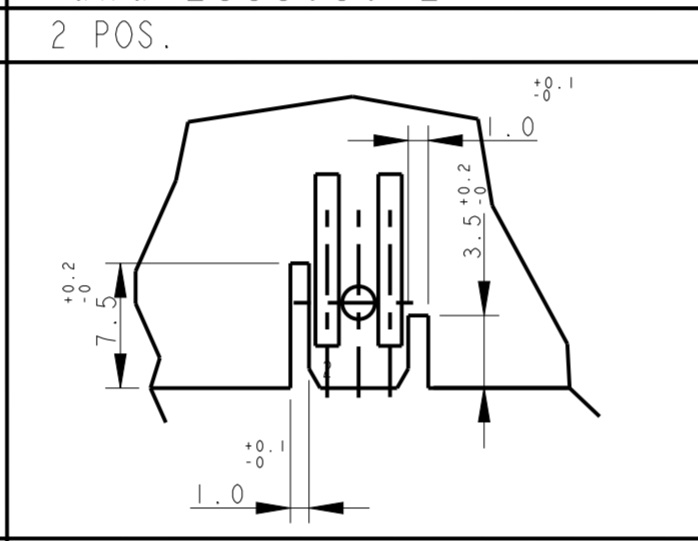

DIMA DEL PCB PER PN (PCB LAYOUT FOR PN.S)  
1-2293372-2

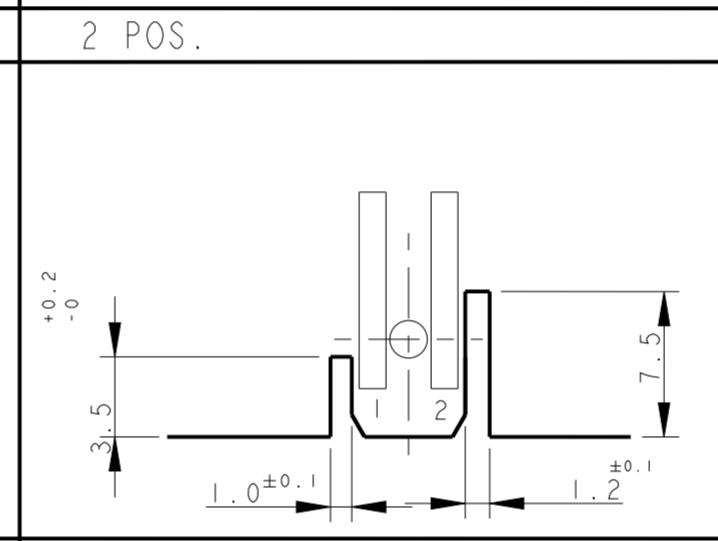

DIMA DEL PCB PER PN (PCB LAYOUT FOR PN.S)  
x-284561-2

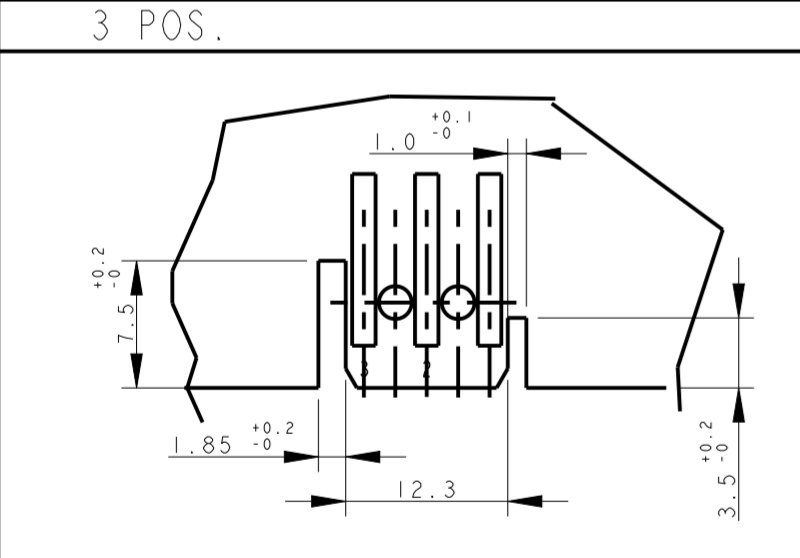

DIMA DEL PCB PER PN (PCB LAYOUT FOR PN.S)  
x-282043-2, x-282043-3, 2298752-3 and 2333039-3

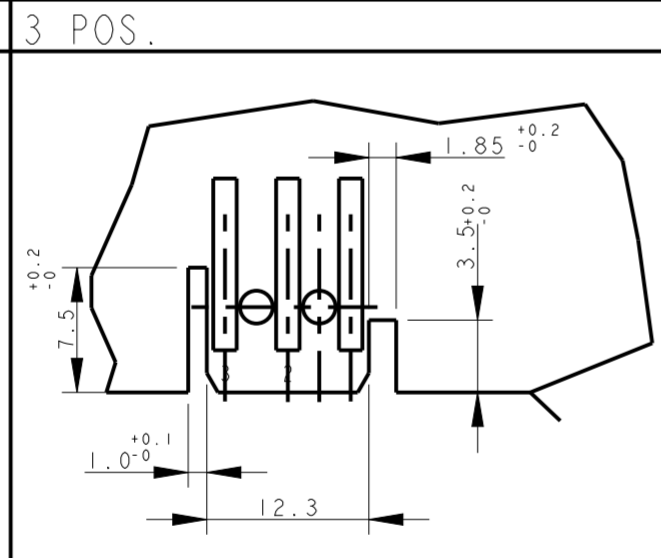

DIMA DEL PCB PER PN (PCB LAYOUT FOR PN.S)  
x-282235-2 and x-282235-3

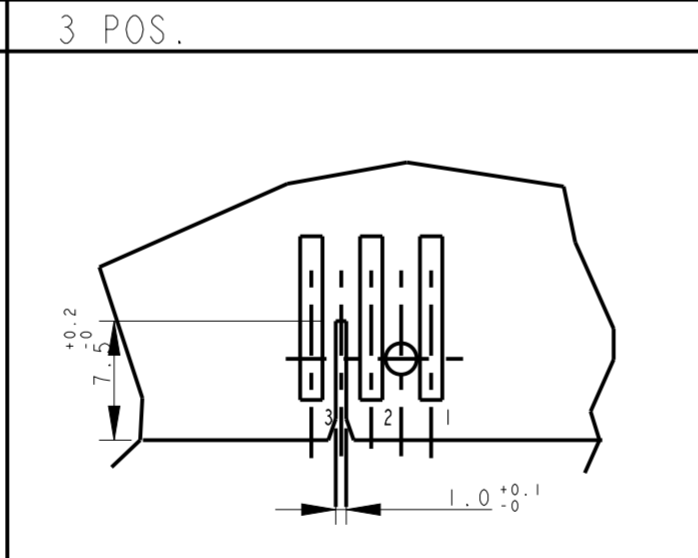

DIMA DEL PCB PER PN (PCB LAYOUT FOR PN.S)  
x-284546-1

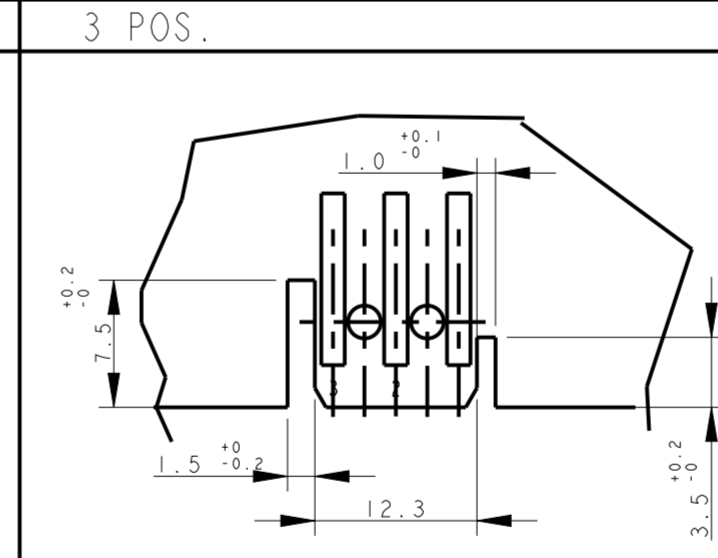

DIMA DEL PCB PER PN (PCB LAYOUT FOR PN.S)  
284546-2

- SUGGESTED SHAPE FOR PCB MATING SIDE, CAN BE ALSO OBTAINED BY SCORING PROCESS-

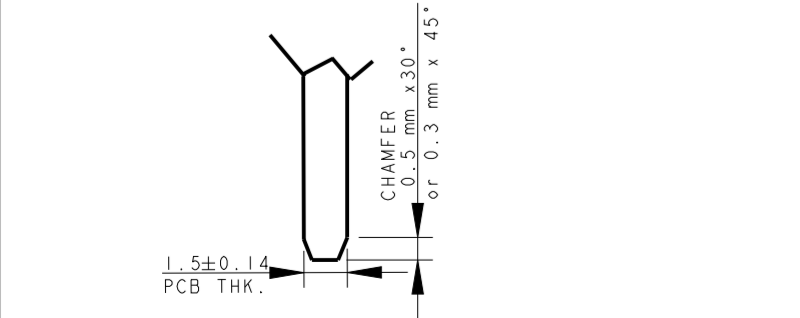

1471-9 (3/13)

- 1) LE DIMENSIONI TIPICHE RIFERITE ALLE GEOMETRIE COMUNI A TUTTE LE DIME SONO INDICATE SOLO NEL DETTAGLIO RELATIVO AL PN 1-282042.  
(PCB GEOMETRY TYPICAL DIMENSIONS ARE SHOWN ON SKETCH FOR PN 1-282042-1)
- 2) LE DIME DEI PCB ACCOPPIANO CON I CONNETTORI INSERITI CO USCITA CAVI VERSO IL BASSO  
(PCB LAYOUT AS SHOWN WILL MATE WITC CONNECTORS HAVING CABLE EXIT DOWN )

THIS DRAWING IS A CONTROLLED DOCUMENT.		DWN C. CORDOLA 23 JUL 1996	TE Connectivity
DIMENSIONS: mm		CHK G. TURCO 23 JUL 1996	
TOLERANCES UNLESS OTHERWISE SPECIFIED:		APVD G. TURCO 23 JUL 1996	NAME MONO-SHAPE, MK1 PCB CONNECTOR 2-12 POS.
0 PLC ±0.3		PRODUCT SPEC 108-20067	SIZE A2
1 PLC ±0.3		APPLICATION SPEC 114-20018	CAGE CODE 1
2 PLC ±0.3		WEIGHT -	DRAWING NO C-282042
3 PLC ±0.3		CUSTOMER DRAWING	RESTRICTED TO
4 PLC ±0.3			SCALE 2:1
ANGLES ±2°			SHEET 5 OF 11
FINISH STAGNATO (TIN PLATED)			REV 739

4

3

2

1

THIS DRAWING IS UNPUBLISHED. RELEASED FOR PUBLICATION  
 © COPYRIGHT copyright.d8te- ALL RIGHTS RESERVED.

REVISIONS					
P	LTR	DESCRIPTION	DATE	DWN	APVD
		SEE SHEET 1			

4 POS.

PCB LAYOUT FOR PNs  
 x-282044-1, 2293372-4  
 2298752-4 and 2333039-4

5 POS.

DIMA DEL PCB PER PN  
 (PCB LAYOUT FOR PN.S)  
 x-282045-1

5 POS.

DIMA DEL PCB PER PN  
 (PCB LAYOUT FOR PN.S)  
 x-282045-2

5 POS.

DIMA DEL PCB PER PN  
 (PCB LAYOUT FOR PN.S)  
 x-282045-3

5 POS.

DIMA DEL PCB PER PN  
 (PCB LAYOUT FOR PN.S)  
 x-284733-1

5 POS.

PCB LAYOUT FOR PN.S  
 3-282045-4 2293372-5  
 2298752-5

**CONNECTOR LAYOUT**  
 3D VIEW FOR REFERENCE TO SHOW THE  
 CONNECTOR ORIENTATION RESPECT TO  
 PCB CUT OUT DESIGN

- SUGGESTED SHAPE FOR PCB MATING  
 SIDE, CAN BE ALSO OBTAINED  
 BY SCORING PROCESS-

1) LE DIMENSIONI TIPICHE RIFERITE ALLE GEOMETRIE COMUNI A TUTTE LE DIME  
 SONO INDICATE SOLO NEL DETTAGLIO RELATIVO AL PN 1-282042.  
 (PCB GEOMETRY TYPICAL DIMENSIONS ARE SHOWN ON SKETCH FOR PN 1-282042-1)

2) LE DIME DEI PCB ACCOPPIANO CON I CONNETTORI INSERITI CO USCITA CAVI  
 VERSO IL BASSO  
 (PCB LAYOUT AS SHOWN WILL MATE WITC CONNECTORS HAVING CABLE  
 EXIT DOWN )

THIS DRAWING IS A CONTROLLED DOCUMENT.		DWN C. CORDOLA 23 JUL 1996	 TE Connectivity
DIMENSIONS: mm		CHK G. TURCO 23 JUL 1996	
TOLERANCES UNLESS OTHERWISE SPECIFIED:		APVD G. TURCO 23 JUL 1996	
0 PLC ± 0.3 1 PLC ± 0.3 2 PLC ± 0.3 3 PLC ± 0.3 4 PLC ± 0.3 ANGLES ± 2°		PRODUCT SPEC 108-20067 APPLICATION SPEC 114-20018 WEIGHT -	
MATERIAL CONNETTORE NYLON (CONNECTOR NYLON) CONTATTO OTTONE (CONTACT BRASS)		FINISH STAGNATO (TIN PLATED)	NAME MONO-SHAPE, MK I PCB CONNECTOR 2-12 POS.
		CUSTOMER DRAWING	SIZE A2 CAGE CODE 1 DRAWING NO. C-282042 RESTRICTED TO
		SCALE 2:1	SHEET 6 OF 11 REV 739

1471-9 (3/13)

THIS DRAWING IS UNPUBLISHED. RELEASED FOR PUBLICATION  
 © COPYRIGHT copyright dbTe- ALL RIGHTS RESERVED.

REVISIONS				
P	LTR	DESCRIPTION	DATE	APVD
-	-	SEE SHEET 1	-	-

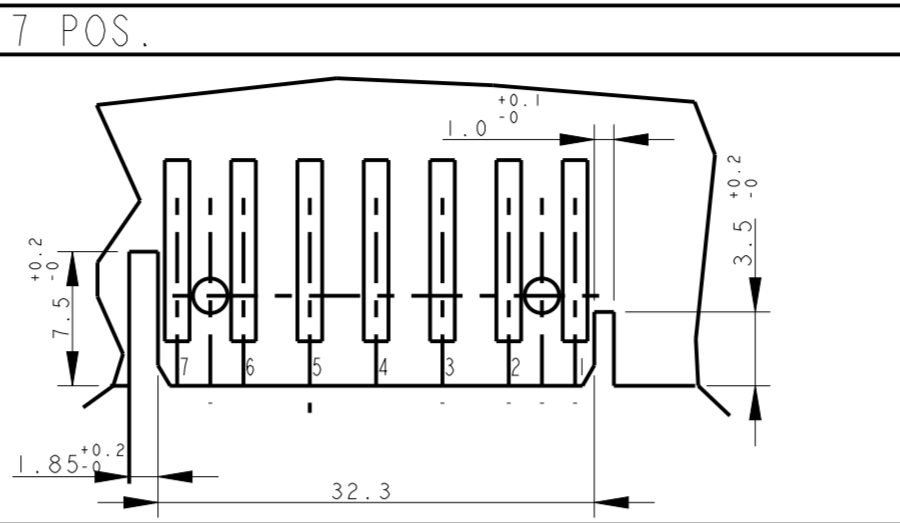
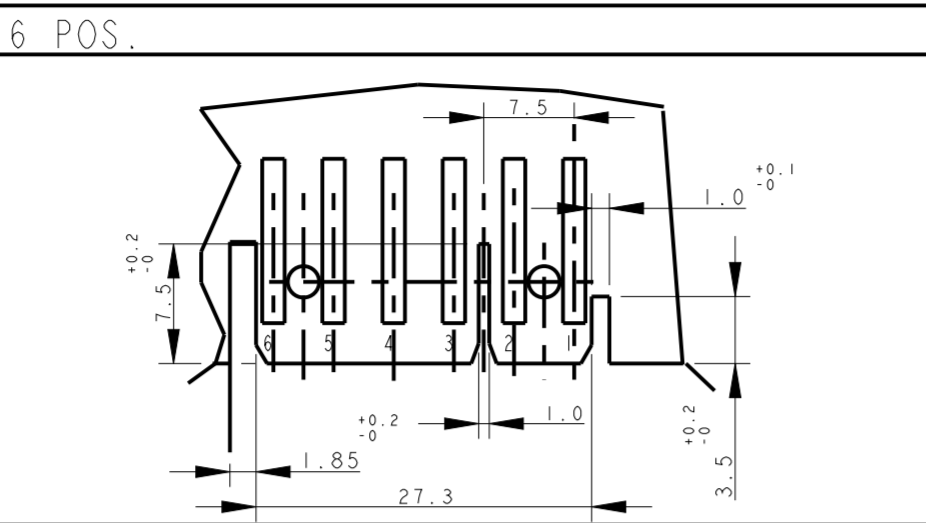
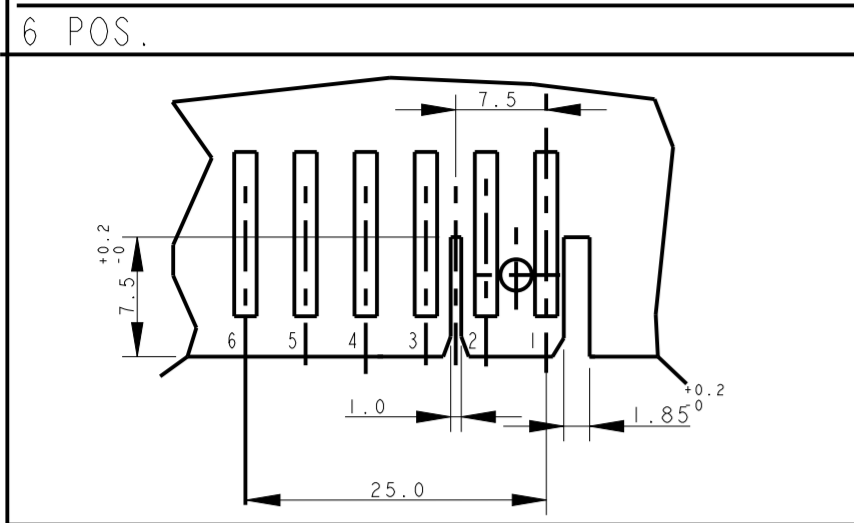

DIMA DEL PCB PER PN  
(PCB LAYOUT FOR PN.S)  
x-284734-1

DIMA DEL PCB PER PN  
(PCB LAYOUT FOR PN.S)  
x-282046-1, 2298752-6 and 2333039-6  
(EXCEPT 4-282046-1, 5-282046-1)

DIMA DEL PCB PER PN  
(PCB LAYOUT FOR PN.S)  
x-282047-1, 2293372-7, 2298752-7  
and 2333039-7

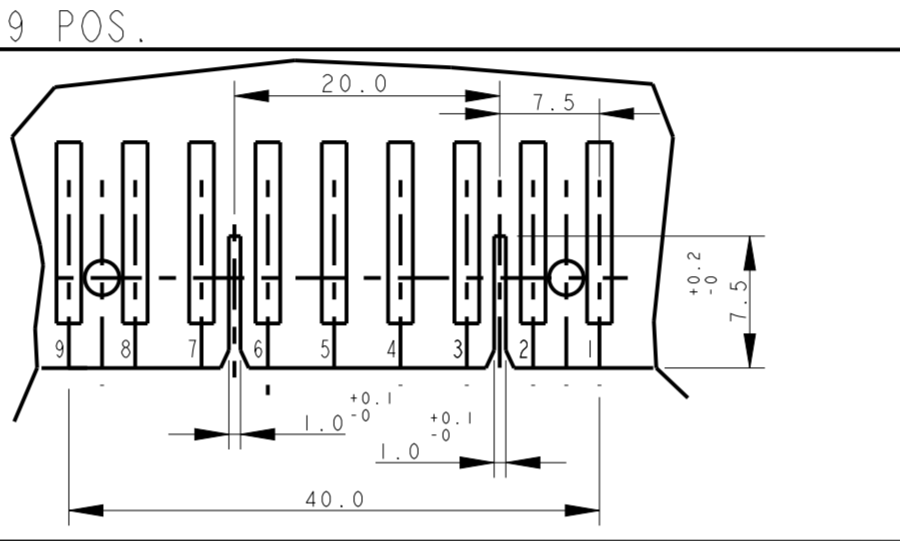
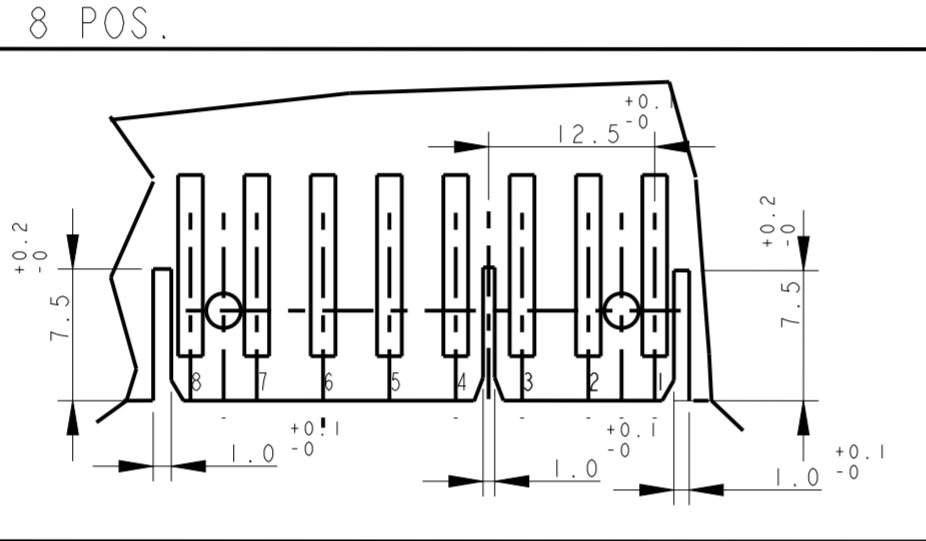
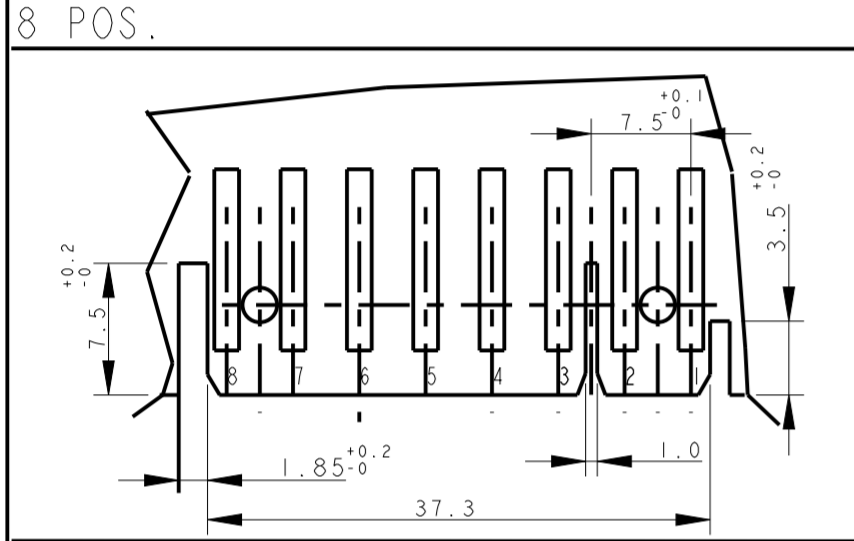

PCB LAYOUT FOR PN.S  
x-284208-1, 2293372-8,  
2298752-8 and 2333039-8

DIMA DEL PCB PER PN  
(PCB LAYOUT FOR PN.S)  
x-284574-1

DIMA DEL PCB PER PN  
(PCB LAYOUT FOR PN.S)  
x-282049-1, 2293372-9 and 2298752-9

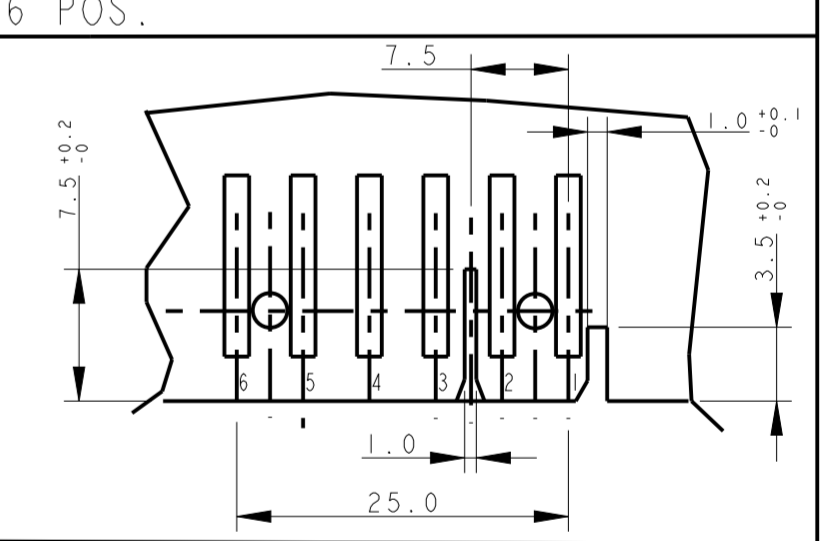
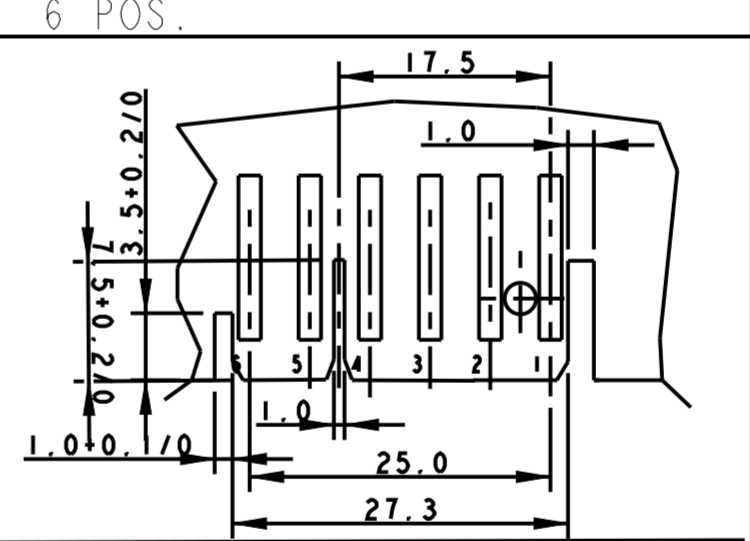
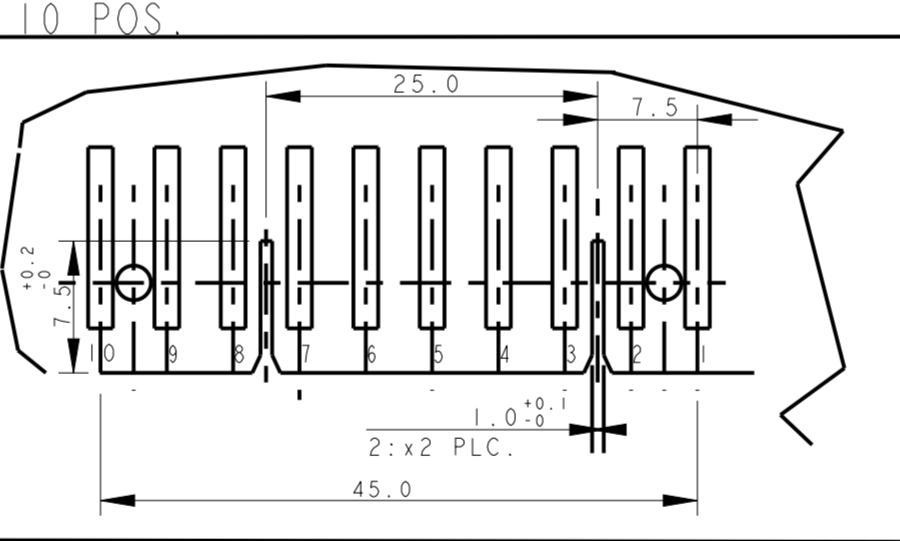
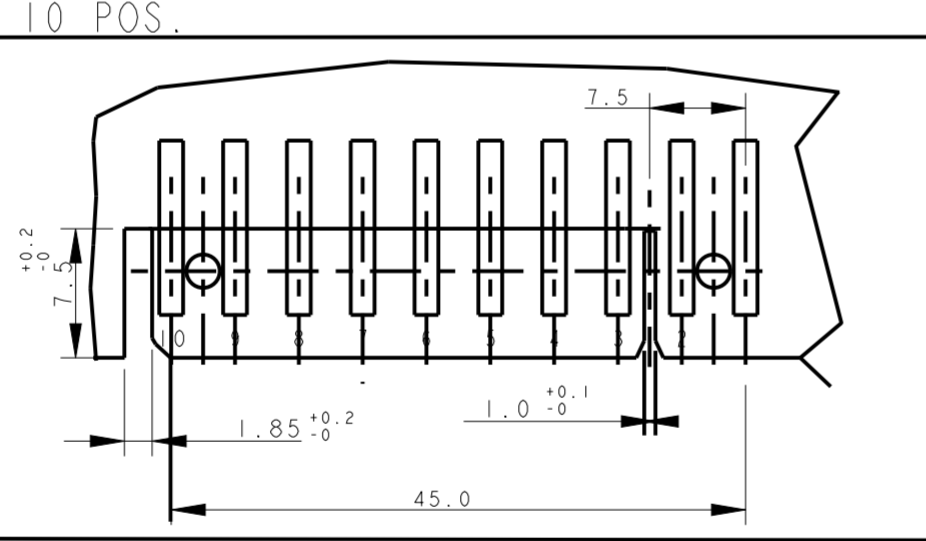
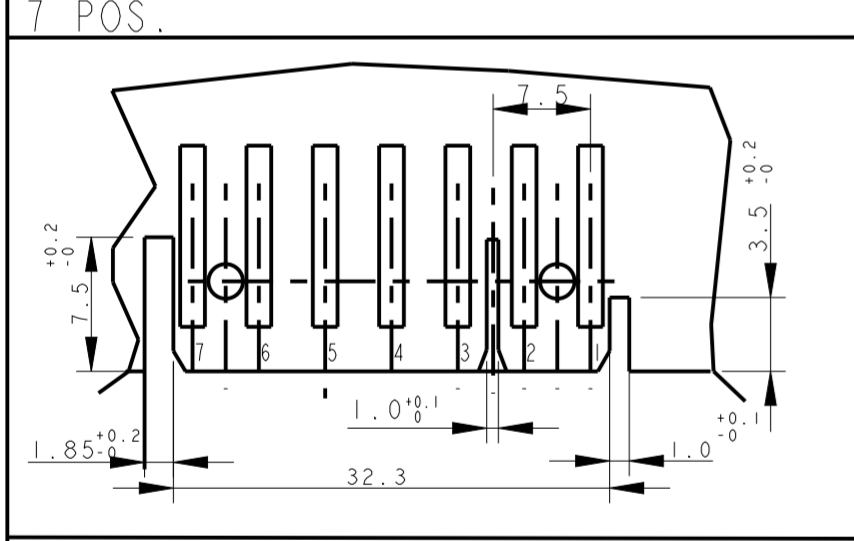

DIMA DEL PCB PER PN  
(PCB LAYOUT FOR PN.S)  
2-282047-3 AND 1-2293372-7

DIMA DEL PCB PER PN  
(PCB LAYOUT FOR PN.S)  
x-284401-x

DIMA DEL PCB PER PN  
(PCB LAYOUT FOR PN.S)  
x-282050-x and 1-2298752-0

DIMA DEL PCB PER PN  
(PCB LAYOUT FOR PN.S)  
4-282046-1 AND 5-282046-1

DIMA DEL PCB PER PN  
(PCB LAYOUT FOR PN.S)  
2-282046-2

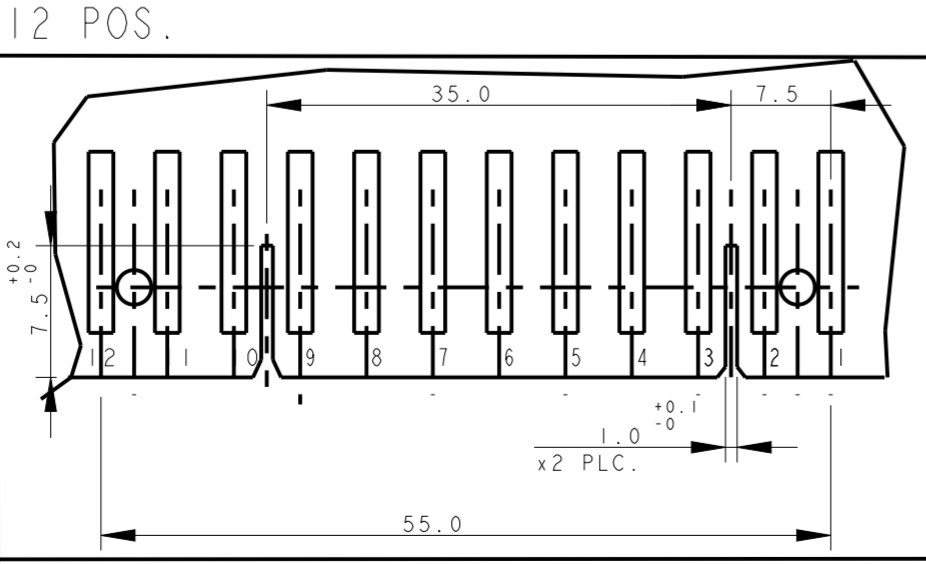
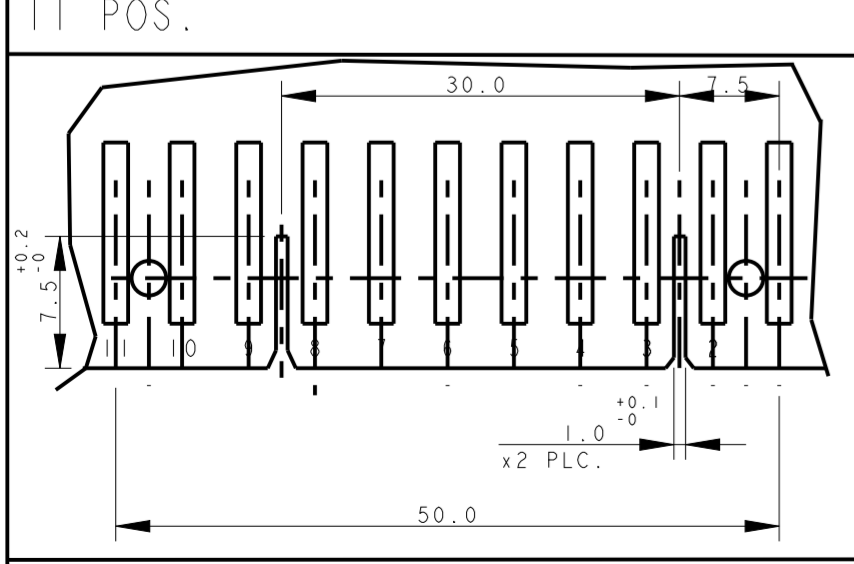

DIMA DEL PCB PER PN  
(PCB LAYOUT FOR PN.S)  
x-282051-x and 2298552-1

PCB LAYOUT FOR PN.S  
x-282052-x, 2297072-2 and 2298552-2

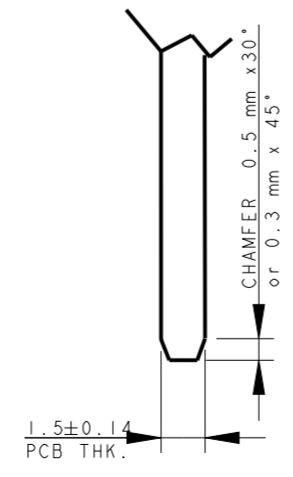

- SUGGESTED SHAPE FOR PCB MATING SIDE, CAN BE ALSO OBTAINED BY SCORING PROCESS-

CONNECTOR LAYOUT  
(3D VIEW FOR REFERENCE TO SHOW THE CONNECTOR ORIENTATION RESPECT TO PCB CUT OUT DESIGN)

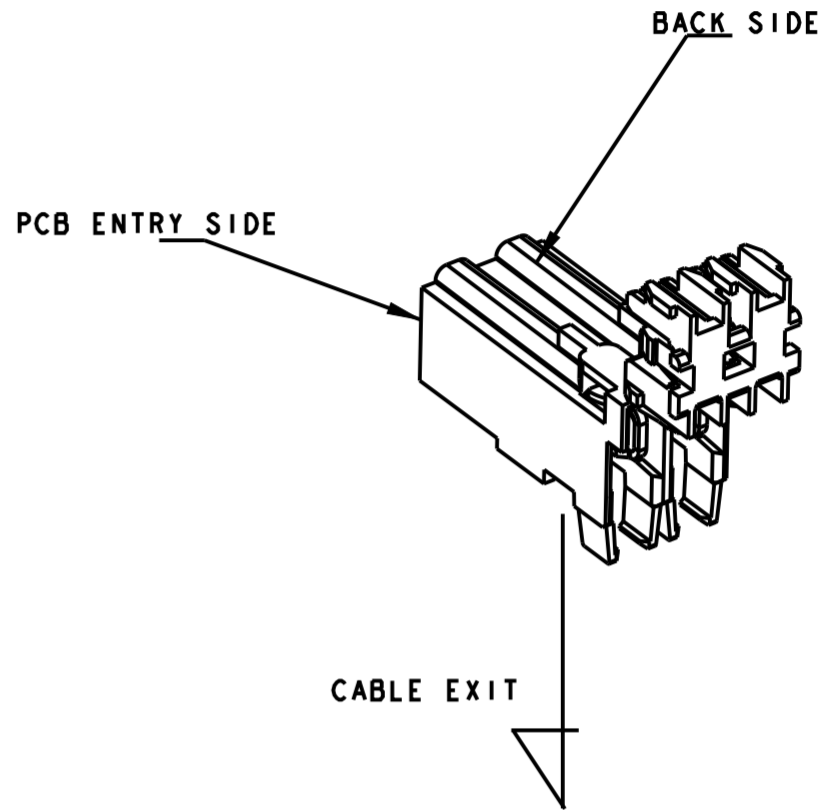

THIS DRAWING IS A CONTROLLED DOCUMENT.		DWN C. CORDOLA 23JUL1996	TE Connectivity
DIMENSIONS: mm		CHK G. TURCO 23JUL1996	
TOLERANCES UNLESS OTHERWISE SPECIFIED:		APVD G. TURCO 23JUL1996	NAME MONO-SHAPE, MK1 PCB CONNECTOR 2-12 POS.
0 PLC ±		PRODUCT SPEC 108-20067	SIZE A2
1 PLC ±		APPLICATION SPEC 114-20018	CAGE CODE 1
2 PLC ±		WEIGHT -	DRAWING NO G-282042
3 PLC ±		CUSTOMER DRAWING	RESTRICTED TO
4 PLC ±			SCALE 2:1
ANGLES ±2°			SHEET 7 OF 11
FINISH STAGNATO (TIN PLATED)			REV 739

REVISIONS				
P	LTR	DESCRIPTION	DATE	APVD
		SEE SHEET 1		

NUMERO DI VIE	CONFIGURAZIONE (VISTA CON USCITA CAVI IN ALTO)	VERSIONE PEZZI IN VASSOIO	REV	VERSIONE PEZZI SCIOLTI	REV	POSIZIONE POLARIZ. (INTERVIA)	L (mm)	MARCHIATURA A CON BANDA COLORATA
NO. OF POS.	CONFIGURATION (VIEW WITH CABLE EXIT UP)	ON TRAY VERSION	PART REV.	LOOSE PIECES PACKAGING VERSION	PART REV.	POLARIZ. POSITION (INTERVIA)	L (mm)	STRIP COLOUR
2		1-282042-1	U	2-282042-1	U	-	10.8	ARANCIONE (ORANGE)
2		1-282042-2	U	2-282042-2	U	-	10.8	VERDE (GREEN)
2		1-282042-3	U	2-282042-3	U	-	9.9	BLU (BLUE)
2		1-282042-4	U	2-282042-4	U	-	10.8	ROSSO (RED)
2		1-282042-5	U	2-282042-5	U	-	9.9	NERO (BLACK)
2		1-282042-6	V	-	-	-	9.9	VIOLA (VIOLET)
2		1-284561-1	V	-	-	-	9.9	VERDE (GREEN)
2		1-284561-2	V	-	-	-	9.9	-
3		1-282043-2	U	2-282043-2	U	-	14.9	-
		<del>1-282043-3</del>	U	<del>2-282043-3</del>	U	-	14.9	NERO (BLACK)
3		<del>0-282235-2</del>	U	<del>2-282235-2</del>	U	-	15.8	-
		<del>0-282235-3</del>	U	<del>2-282235-3</del>	U	-	15.8	NERO (BLACK)
		1-284546-1	V	-	-	2-3	14.9	BLU (BLUE)
3		284546-2	Z	-	-	-	14.9	VERDE (GREEN)
4		1-282044-1	V	2-282044-1	V	-	19.9	-
		3-282044-1	V	-	-	-	19.9	-

CONNETTORE COMPLETO DI CAVO (TERMINATED CONNECTOR)

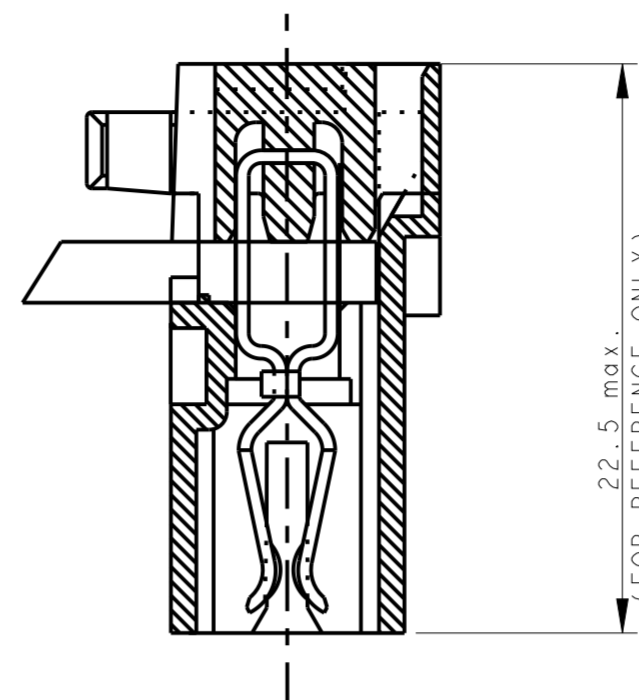

22.5 max.  
(FOR REFERENCE ONLY)

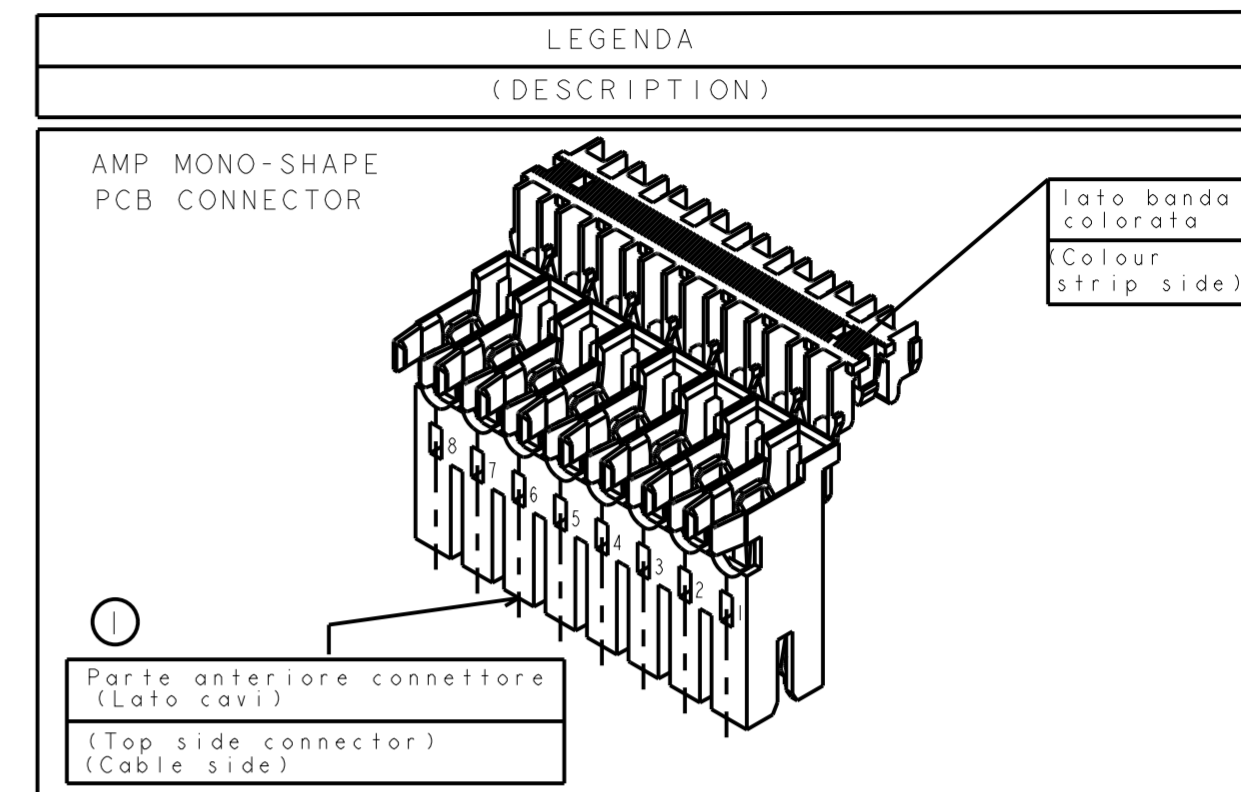

1) PER LE DIMENSIONI DEGLI SCARICHI SUL PCB VEDERE FOGLIO 5 E 6 (FOR PCB LAYOUT AND DIMENSIONS SEE SHEET 5 AND 6)

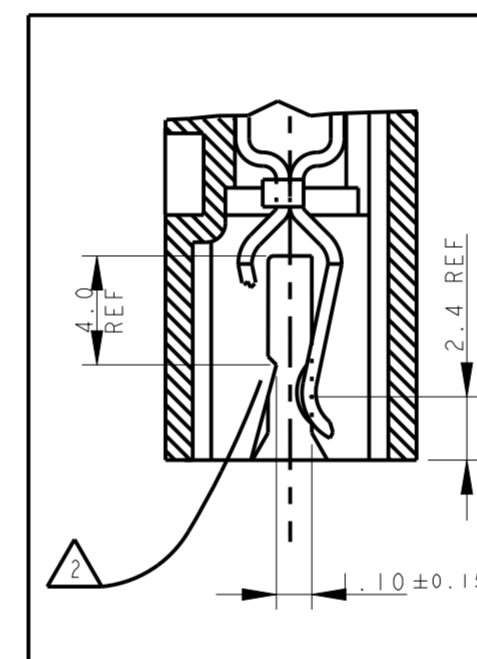

2) GLI AGGANCI PER DIMA CIRCUITO STAMPATO, SONO SEMPRE RICAVATI SULLA SECONDA E PENULTIMA PARETE DEL BLOCCETTO (INDICATI COME X-Y SUI DETTAGLI DEL DISEGNO) (LOCKING TEETH ARE OBTAINED ON THE SECOND AND THE SECOND-LAST WALL (NAMED X-Y ON RELEVANT DWG. DETAILS))

3) MARCHIO DI FABBRICA (LIBERA POSIZIONE) (TRADEMARK) (FREE POSITION)

4) NUMERI DI IDENTIFICAZIONE CAVITA' (CIRCUIT IDENTIFICATION)

5) ADATTO PER SCHEDA CIRCUITO STAMPATO SPESSORE 1.5±0.14 (SUITABLE FOR P.C.B. THK. 1.5±0.14)

6) PRELIMINARY PART - NOT YET RELEASED FOR PRODUCTION

12) INCLUDE LA POLARIZZAZIONE DOVE E' ESISTENTE (INCLUDING POLARIZATION KEY, WHEN EXISTING)

15) STATO DI FORNITURA: CONFEZIONAMENTO IN "VASSOI + SCATOLA" (PACKAGING: "ON TRAY PLUS CARTON BOX")

16) CONFEZIONAMENTO IN BOBINA OBSOLETATO (PACKAGING: "ON REEL" OBSOLETE)

17) APPROVAZIONE VDE, FILE No. 3905 (VDE APPROVAL, FILE No. 3905)

18) PROFILO "A" E' VALIDO PER OGNI CONFIGURAZIONE, PROFILO "B" E' AMMESSO SOLO PER I PN IDENTIFICATI IN TABELLA DALLA PRESENTE NOTA. VEDERE DETTAGLI A PAGINA 3. (SHAPE "A" VALID FOR EACH CONFIGURATION, SHAPE "B" IS PERMITTED ONLY ON PN WHERE THIS NOTE IS SHOWN ON RELEVANT DRAWING TABLE). SEE DETAILS AT PAGE 3.

19) OBSOLETE: CIS STREAMLINING PER D.RENAUD/D.SINISI

20) OBSOLETE



21) PA GF, UL-V0 GWEPT 750°C NO FLAME, NATURAL

2	BLOCCETTO (HOUSING)	NATURALE (NATURAL)	PA 6.6 CARICATO VETRO (POLIAMIDE 6.6 GLASSFIBER FILLED)
1	CONTATTO (CONTACT)	STAGNATO (TIN-PLATED)	OTTONE (BRASS)
ITEM	DENOMINAZIONE (DESCRIPTION)	FINITURA/COLORE (FINISH/COLOUR)	MATERIALE (MATERIAL)

THIS DRAWING IS A CONTROLLED DOCUMENT.		DWN 23 JUL 1996 C. CORDOLA	TE Connectivity
DIMENSIONS: mm		CHK 23 JUL 1996 G. TURCO	
TOLERANCES UNLESS OTHERWISE SPECIFIED:		APVD 23 JUL 1996 G. TURCO	NAME MONO-SHAPE, MK1 PCB CONNECTOR 2-12 POS.
0 PLC ±0.3		PRODUCT SPEC 108-20067	SIZE A2
1 PLC ±0.3		APPLICATION SPEC 114-20018	CAGE CODE 1
2 PLC ±0.3		WEIGHT -	DRAWING NO. C-282042
3 PLC ±0.3		CUSTOMER DRAWING	RESTRICTED TO
4 PLC ±0.3			SCALE - SHEET 8 OF 11 REV 739
ANGLES ±2°			
MATERIAL CONNETTORE NYLON (CONNECTOR NYLON) CONTATTO OTTONE (CONTACT BRASS)		FINISH STAGNATO (TIN PLATED)	



REVISIONS				
P	LTR	DESCRIPTION	DATE	APVD
		SEE SHEET 1		

NUMERO DI VIE	CONFIGURAZIONE (VISTA CON USCITA CAVI IN ALTO)	VERSIONE PEZZI IN VASSOIO	REV	VERSIONE PEZZI SCIOLTI	REV	POSIZIONE POLARIZ. (INTERVIA)	L (mm)	MARCHIATURA A CON BANDA COLORATA
NO. OF POS.	CONFIGURATION (VIEW WITH CABLE EXIT UP)	ON TRAY VERSION	PART REV.	LOOSE PIECES PACKAGING VERSION	PART REV.	POLARIZ. POSITION (INTERVIA)	L (mm)	STRIP COLOUR
5		1-282045-1	U	2-282045-1	U	-	24.9	-
5		1-282045-2	U	2-282045-2	U	2-3	24.9	VERDE (GREEN)
5		1-282045-3	U	2-282045-3	U	2-3	24.9	BLU (BLUE)
5		1-284733-1	U	<del>2-284733-1</del>	U	-	24.9	-
5		3-282045-4	Z	-	-	1-2	24.9	ARANCIONE (ORANGE)
6		1-282046-1	U	2-282046-1	U	2-3	29.9	-
6		2-282046-2	I	-	-	2-3	29.9	-
6		4-282046-1	Z	5-282046-1	I	2-3	29.9	-
6		1-284734-1	U	<del>2-284734-1</del>	U	2-3	29.9	-
7		1-282047-1	U	2-282047-1	U	-	34.9	-
7		2-282047-3	Z	-	-	2-3	34.9	VIOLA (VIOLET)
8		0-284208-1	U	<del>2-284208-1</del>	U	2-3	39.9	-
9		1-282049-1	U	2-282049-1	U	2-3 6-7	44.9	-
10		1-282050-1	U	2-282050-1	U	2-3 7-8	49.9	-
10		1-284401-1	V	-	-	2-3	49.9	NERO (BLACK)
11		1-282051-1	U	<del>2-282051-1</del>	U	2-3 8-9	54.9	-
12		1-282052-1	U	2-282052-1	U	2-3 9-10	59.9	-

CONNETTORE COMPLETO DI CAVO (TERMINATED CONNECTOR)

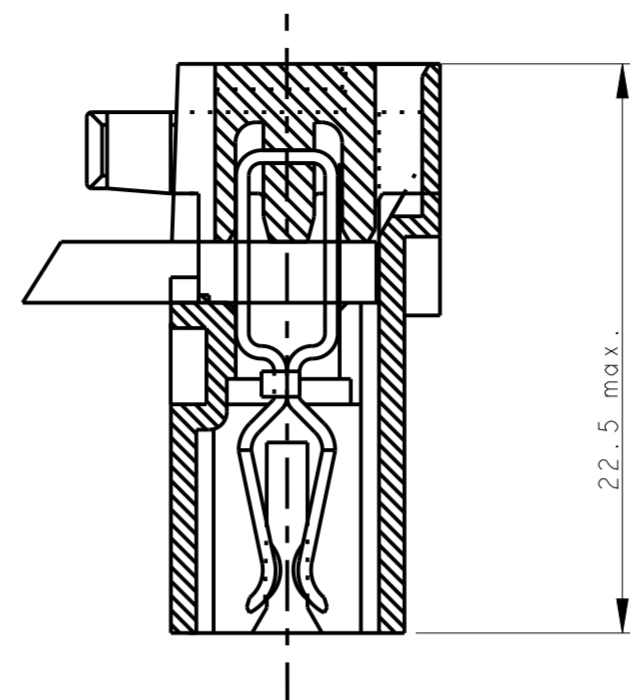

22.5 max. (FOR REFERENCE ONLY)

LEGENDA (DESCRIPTION)

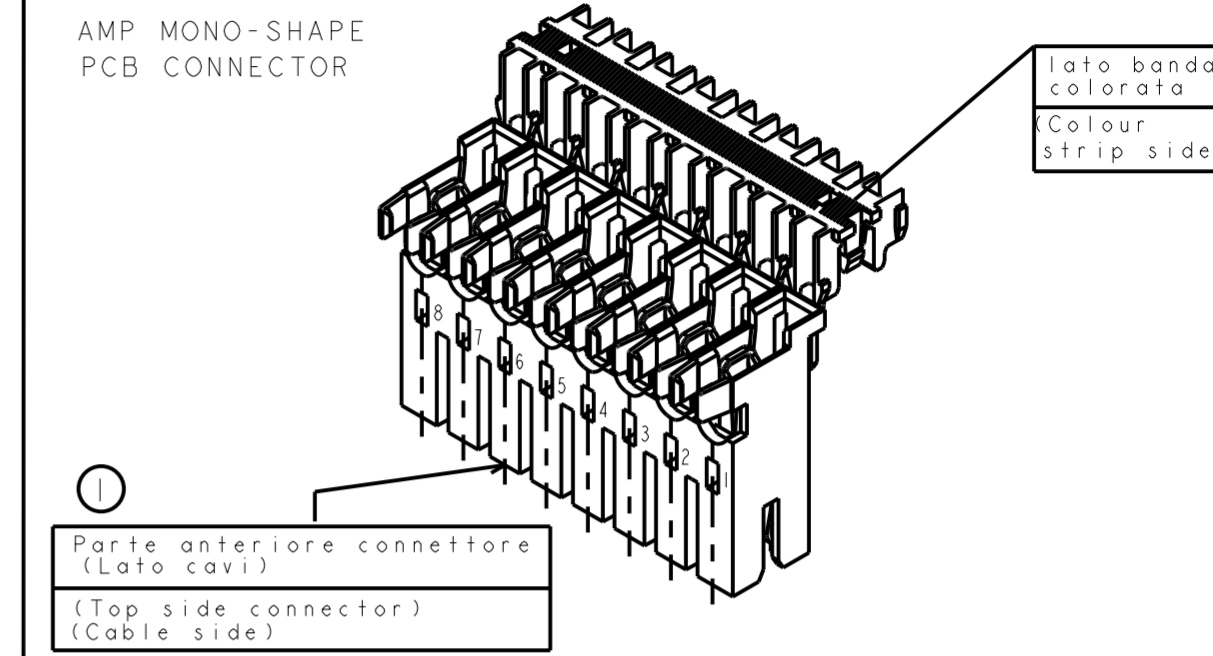

1) PER LE DIMENSIONI DEGLI SCARICHI SUL PCB VEDERE FOGLIO 5 E 6 (FOR PCB LAYOUT AND DIMENSIONS SEE SHEET 5 AND 6)

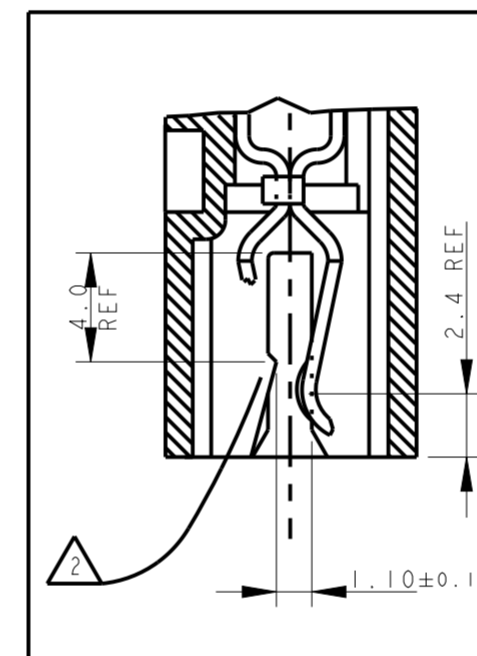

2) GLI AGGANCI PER DIMA CIRCUITO STAMPATO, SONO SEMPRE RICAVATI SULLA SECONDA E PENULTIMA PARETE DEL BLOCCETTO (INDICATI COME X-Y SUI DETTAGLI DEL DISEGNO) (LOCKING TEETH ARE OBTAINED ON THE SECOND AND THE SECOND-LAST WALL (NAMED X-Y ON RELEVANT DWG. DETAILS))

3) MARCHIO DI FABBRICA (LIBERA POSIZIONE) (TRADEMARK) (FREE POSITION)

4) NUMERI DI IDENTIFICAZIONE CAVITA' (CIRCUIT IDENTIFICATION)

5) ADATTO PER SCHEDA CIRCUITO STAMPATO SPESSORE 1.5±0.14 (SUITABLE FOR P.C.B. THK. 1.5±0.14)

6) PRELIMINARY PART - NOT YET RELEASED FOR PRODUCTION

12) INCLUDE LA POLARIZZAZIONE DOVE E' ESISTENTE (INCLUDING POLARIZATION KEY, WHEN EXISTING)

15) STATO DI FORNITURA: CONFEZIONAMENTO IN "VASSOI + SCATOLA" (PACKAGING: "ON TRAY PLUS CARTON BOX")

16) CONFEZIONAMENTO IN BOBINA OBSOLETATO (PACKAGING: "ON REEL" OBSOLETE)

17) APPROVAZIONE VDE, FILE No. 3905 (VDE APPROVAL, FILE No. 3905)

18) PROFILO "A" E' VALIDO PER OGNI CONFIGURAZIONE, PROFILO "B" E' AMMESSO SOLO PER I PN IDENTIFICATI IN TABELLA DALLA PRESENTE NOTA (SHAPE "A" VALID FOR EACH CONFIGURATION, SHAPE "B" IS PERMITTED ONLY ON PN WHERE THIS NOTE IS SHOWN ON RELEVANT DRAWING TABLE)

19) OBSOLETE: CIS STREAMLINING PER D.RENAUD/D.SINISI

20) OBSOLETE

21) PA GF, UL-V0 GWEPT 750°C NO FLAME, NATURAL



2	BLOCCETTO (HOUSING)	NATURALE (NATURAL)	PA 6.6 CARICATO VETRO (POLIAMIDE 6.6 GLASSFIBER FILLED)
1	CONTATTO (CONTACT)	STAGNATO (TIN-PLATED)	OTTONE (BRASS)
ITEM	DENOMINAZIONE (DESCRIPTION)	FINITURA/COLORE (FINISH/COLOUR)	MATERIALE (MATERIAL)

THIS DRAWING IS A CONTROLLED DOCUMENT.		DWN C. CORDOLA 23 JUL 1996	TE Connectivity	
DIMENSIONS: mm		CHK G. TURCO 23 JUL 1996		
TOLERANCES UNLESS OTHERWISE SPECIFIED:		APVD G. TURCO 23 JUL 1996	NAME MONO-SHAPE, MK1 PCB CONNECTOR 2-12 POS.	
0 PLC ±0.3 1 PLC ±0.3 2 PLC ±0.3 3 PLC ±0.3 4 PLC ±0.3		PRODUCT SPEC 108-20067	SIZE A2	
ANGLES ±2°		APPLICATION SPEC 114-20018	CAGE CODE 1	
MATERIAL CONNETTORE NYLON (CONNECTOR NYLON) CONTATTO OTTONE (CONTACT BRASS)		FINISH STAGNATO (TIN PLATED)	DRAWING NO C-282042	
		WEIGHT -	RESTRICTED TO	
		CUSTOMER DRAWING	SCALE 2:1 SHEET 9 OF 11 REV 739	

THIS DRAWING IS UNPUBLISHED. RELEASED FOR PUBLICATION  
 © COPYRIGHT copyright.d8te- ALL RIGHTS RESERVED.

REVISIONS				
P	LTR	DESCRIPTION	DATE	APVD
-	-	SEE SHEET 1	-	-

21 PA GF, UL-V0 GWEPT 750°C NO FLAME, NATURAL

NO of POS.	CONFIGURATION (SEE TYP. SECTION ONLY FOR REF. ①)	ON TRAY PACKAGING VERSION	PART REV.	LOOSE PIECES PACKAGING VERSION	PART REV.	POLARIZ. POSITION (INTERVIA)	"L" (mm)	COLOR CODE
2		2293372-2	Z	-	-	-	9.9	BLUE
2		1-2293372-2	Z	-	-	-	9.9	-
3	-	2293372-3	I	-	-	-	14.9	-
4		2293372-4	Z	-	-	-	19.9	-
5		2293372-5	Z	-	-	1-2	24.9	-
6		2293372-6	Z	-	-	2-3	29.9	-
7		2293372-7	Z	-	-	-	34.9	-
7		1-2293372-7	I	-	-	2-3	34.9	VIOLET
8		2293372-8	Z	-	-	-	39.9	-
9		2293372-9	Z	-	-	2-3 6-7	44.9	-
10	-	1-2293372-0	I	-	-	-	49.9	-
11	-	2297072-1	I	-	-	-	54.9	-
12		2297072-2	I	-	-	2-3 9-10	59.9	-

THIS DRAWING IS A CONTROLLED DOCUMENT.		DWN C. CORDOLA 23 JUL 1996	TE Connectivity	
DIMENSIONS: mm		CHK G. TURCO 23 JUL 1996		
TOLERANCES UNLESS OTHERWISE SPECIFIED:		APVD G. TURCO 23 JUL 1996	NAME MONO-SHAPE, MK I PCB CONNECTOR 2-12 POS.	
		PRODUCT SPEC 108-20067	RESTRICTED TO	
MATERIAL CONNETTORE NYLON (CONNECTOR NYLON) CONTATTO OTTONE (CONTACT BRASS)		APPLICATION SPEC 114-20018	SIZE A2	CAGE CODE 1
FINISH STAGNATO (TIN PLATED)		WEIGHT -	DRAWING NO C-282042	SCALE 2:1
CUSTOMER DRAWING		SHEET 10 OF 11		REV. 739

THIS DRAWING IS UNPUBLISHED. RELEASED FOR PUBLICATION  
 © COPYRIGHT copyright.d8te- ALL RIGHTS RESERVED.

REVISIONS				
P	LTR	DESCRIPTION	DATE	APVD
-		SEE SHEET 1	-	-

△ PA GF, UL-V0 GWEPT 750°C NO FLAME, NATURAL

LONG VERSION

PARTS HAVE NOT YET COMPLETED QUALIFICATION TESTING

NO. of POS.	CONFIGURATION (SEE TYP. SECTION ONLY FOR REF.)	ON TRAY PACKAGING VERSION	PART REV.	POLARIZ. POSITION (INTERNAL)	"L" (mm)	COLOR CODE
2		2298752-2	Z	-	9.9	BLUE
2		1-2298752-2	Z	-	9.9	BLACK
3		2298752-3	Z	-	14.9	-
4		2298752-4	Z	-	19.9	-
5		2298752-5	Z	1-2	24.9	ORANGE
5		1-2298752-5	Z	2-3	24.9	GREEN
6		2298752-6	Z	2-3	29.9	-
7		2298752-7	Z	-	34.9	-
8		2298752-8	Z	2-3	39.9	-
9		2298752-9	Z	2-3 6-7	44.9	-
10		1-2298752-0	Z	2-3 7-8	49.9	-
11		2298552-1	Z	2-3 8-9	54.9	-
12		2298552-2	Z	2-3 9-10	59.9	-

LONG VERSION

PARTS HAVE NOT COMPLETED QUALIFICATION TESTING

PA GF, UL-V2, NATURAL

NO. OF POS.	CONFIGURATION	ON TRAY PACKAGING VERSION	PART REV.	POLARIZATION	"L"	COLOR CODE
2		2333039-2	Z	-	9.9	BLUE
2		1-2333039-2	Z	-	9.9	BLACK
3		2333039-3	Z	-	14.9	-
4		2333039-4	Z	-	19.9	-
5		2333039-5	Z	2-3	24.9	GREEN
6		2333039-6	Z	2-3	29.9	-
7		2333039-7	Z	-	34.9	-
8		2333039-8	Z	2-3	39.9	-

VIEW APPLIES TO LONG VERSION ONLY

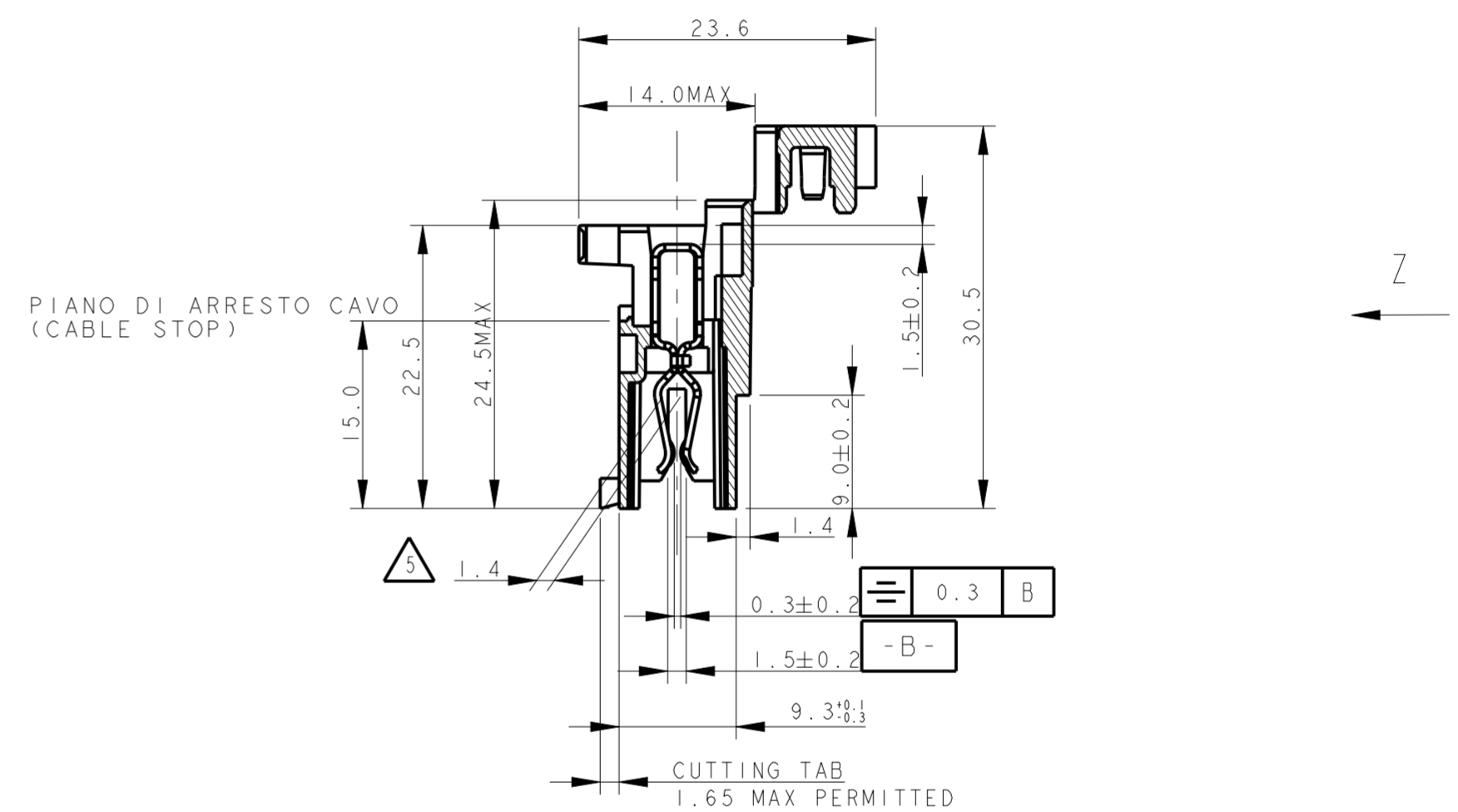

THIS DRAWING IS A CONTROLLED DOCUMENT.		DWN C. CORDOLA 23 JUL 1996		TE Connectivity	
DIMENSIONS: mm		CHK G. TURCO 23 JUL 1996		NAME MONO-SHAPE, MK1 PCB CONNECTOR 2-12 POS.	
TOLERANCES UNLESS OTHERWISE SPECIFIED:		APVD G. TURCO 23 JUL 1996	PRODUCT SPEC 108-20067		
0 PLC ± 0.3 1 PLC ± 0.3 2 PLC ± 0.3 3 PLC ± 0.3 4 PLC ± 0.3		APPLICATION SPEC 114-20018		SIZE A2	CAGE CODE 1
ANGLES ± 2° FINISH STAGNATO (TIN PLATED)		WEIGHT -		DRAWING NO. C-282042	RESTRICTED TO
MATERIAL CONNETTORE NYLON (CONNECTOR NYLON) CONTATTO OTTONE (CONTACT BRASS)		CUSTOMER DRAWING		SCALE 2:1	SHEET 11 OF 11

## X-ON Electronics

Largest Supplier of Electrical and Electronic Components

*Click to view similar products for [Headers & Wire Housings](#) category:*

*Click to view products by [TE Connectivity](#) manufacturer:*

Other Similar products are found below :

[892-18-020-10-001101](#) [58102-G61-06LF](#) [582553-1](#) [0009485154](#) [009176003701906](#) [0050291907](#) [LY20-4P-DT1-P1E-BR](#) [02.125.8002.8](#)  
[609-3404](#) [61062-3](#) [61082-181009](#) [622-3653LF](#) [63453-116](#) [636-1030](#) [636-1427](#) [636-3427](#) [636-4007](#) [641938-9](#) [641991-4](#) [644827-2](#) [65817-010LF](#) [65817-015LF](#) [65863-015LF](#) [66207-023LF](#) [67095-007LF](#) [67601157](#) [68645-018](#) [68648-049](#) [70.362.1628.0](#) [70-4210](#) [70-4226B](#) [70-4853B](#) [707-5020](#) [707-5028](#) [71.350.2428.0](#) [71918-208LF](#) [71961-016LF](#) [733-134](#) [733-162](#) [754199-000](#) [760-3052](#) [787-8014-00](#) [79531-3000](#)  
[FCN-360C032-B](#) [FCN-367T-T012/H](#) [FCN-723D010/2](#) [80.063.4001.1](#) [800-90-001-10-001000](#) [800-90-010-10-002000](#) [801-43-002-10-013000](#)