

- NOTE:
- 1. MATERIAL: SHIELD - 35% GLASS REINFORCED NYLON. SEE TABLE BELOW FOR COLOR. LEVER - 35% GLASS REINFORCED NYLON. COLOR GREY.
 - 2. REFERENCE: RECEPTACLE HOUSING, 1326133-1 USED WITH THIS ASSEMBLY.
 - 3. REFER TO INSTRUCTION SHEET 408-8662 FOR PRODUCT ASSEMBLY AND DISASSEMBLY PROCEDURES.
 - 4. REFER TO USCAR-2 REV 3 APRIL 2001 FOR PRODUCT SPECIFICATIONS.
 - 5. REFER TO DRAWING NO. AUAUT00000-2962-0536 FOR INTERFACE DETAILS.

LOC	DIST	REV	DATE	BY	CHKD	APPD
FX	00	0	01JAN03	SPT	AME	
		A	08JUL2003	RGV	AME	
		A1	28MAY2010	VSS	CS	

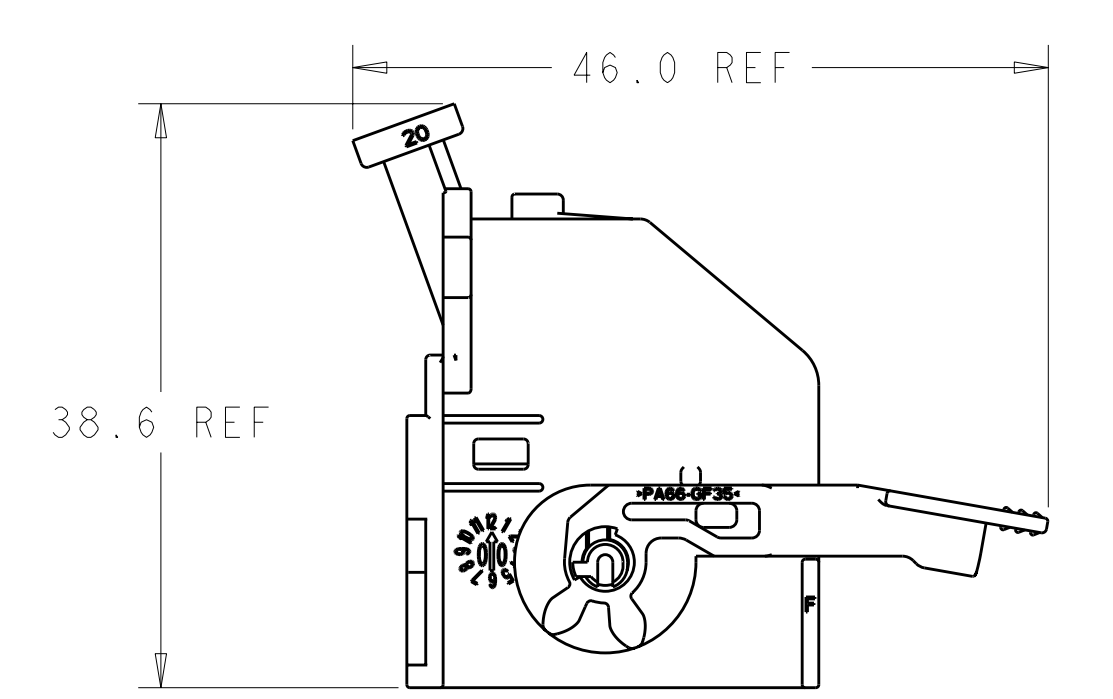
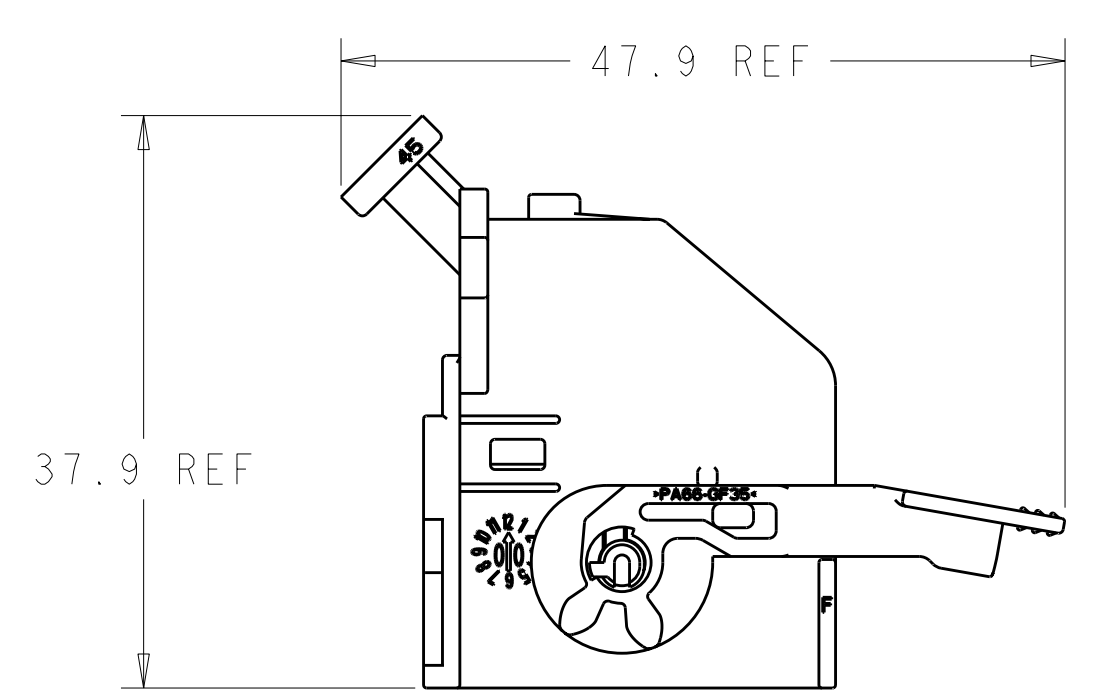
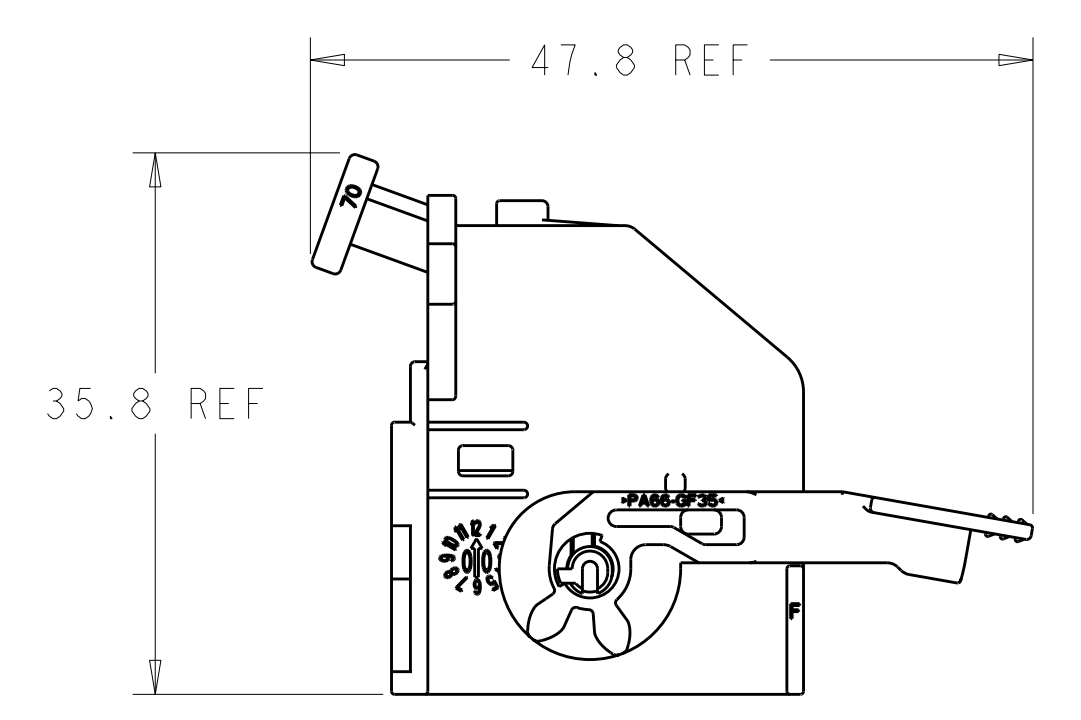

**WIRE EXIT OPTIONS
REFERENCE ONLY**

DIM-W	COLOR	KEYING OPT.	PART NO.
20°	GREEN	C-E	I-1326132-2
20°	PURPLE	B-F	I-1326132-1
20°	NATURAL	B-E	I-1326132-0
20°	BLACK	C-F	I326132-9
45°	GREEN	C-E	I326132-8
45°	PURPLE	B-F	I326132-7
45°	NATURAL	B-E	I326132-6
45°	BLACK	C-F	I326132-5
70°	GREEN	C-E	I326132-4
70°	PURPLE	B-F	I326132-3
70°	NATURAL	B-E	I326132-2
70°	BLACK	C-F	I326132-1

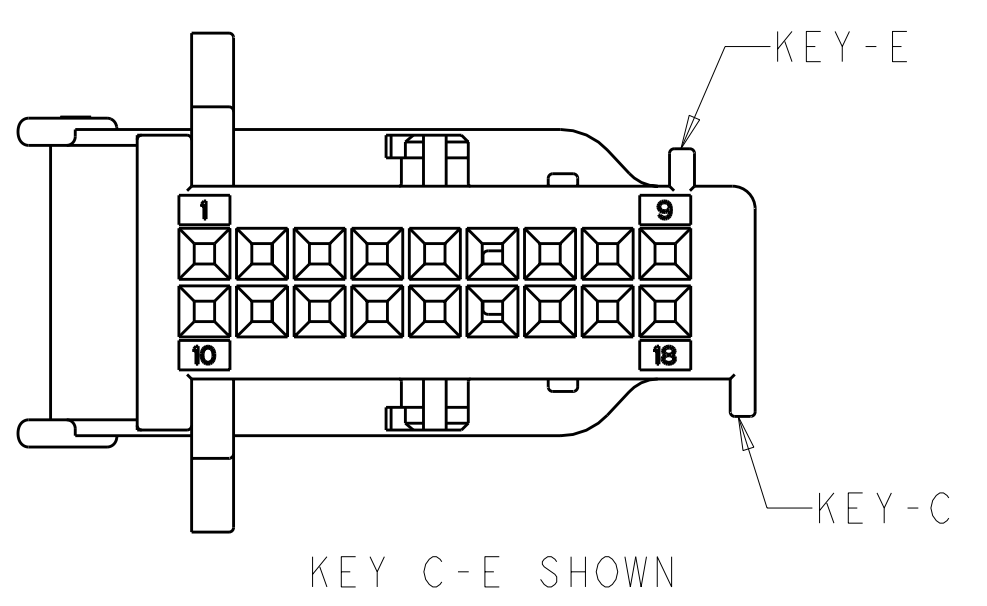
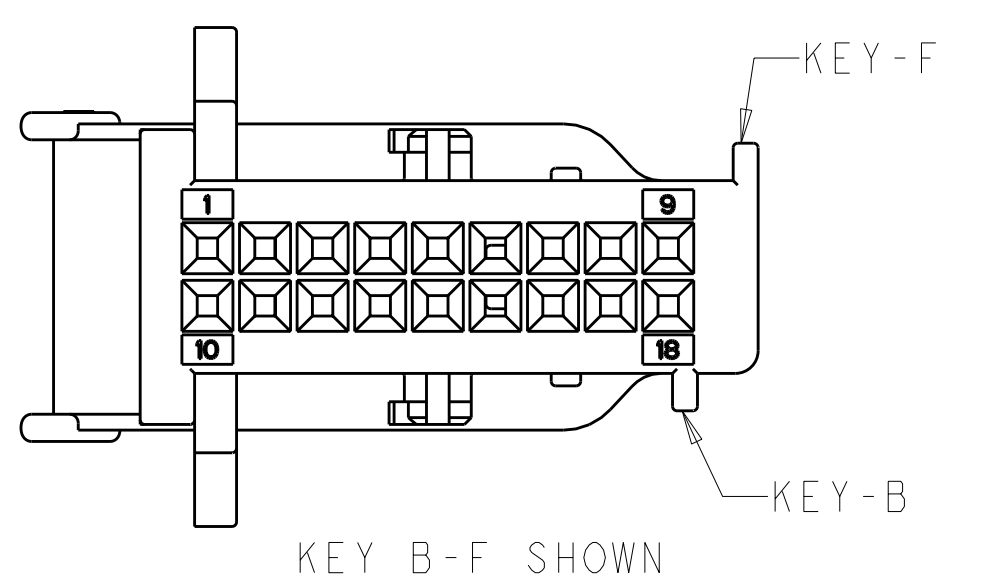
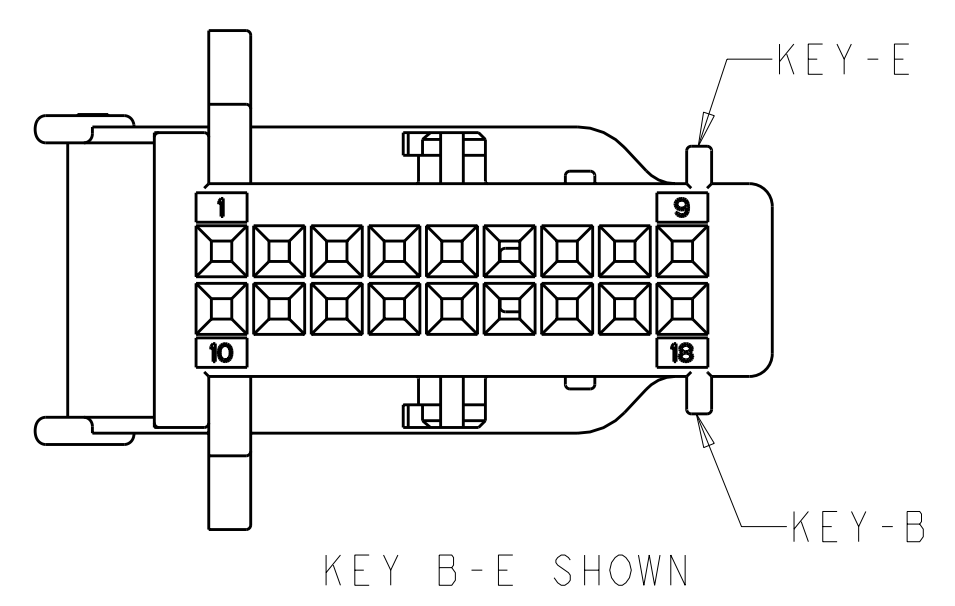
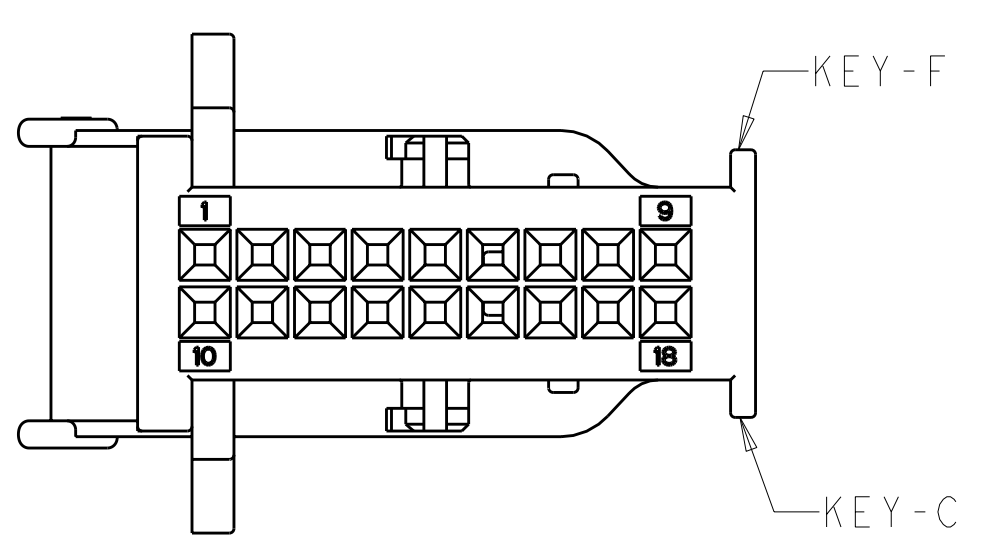
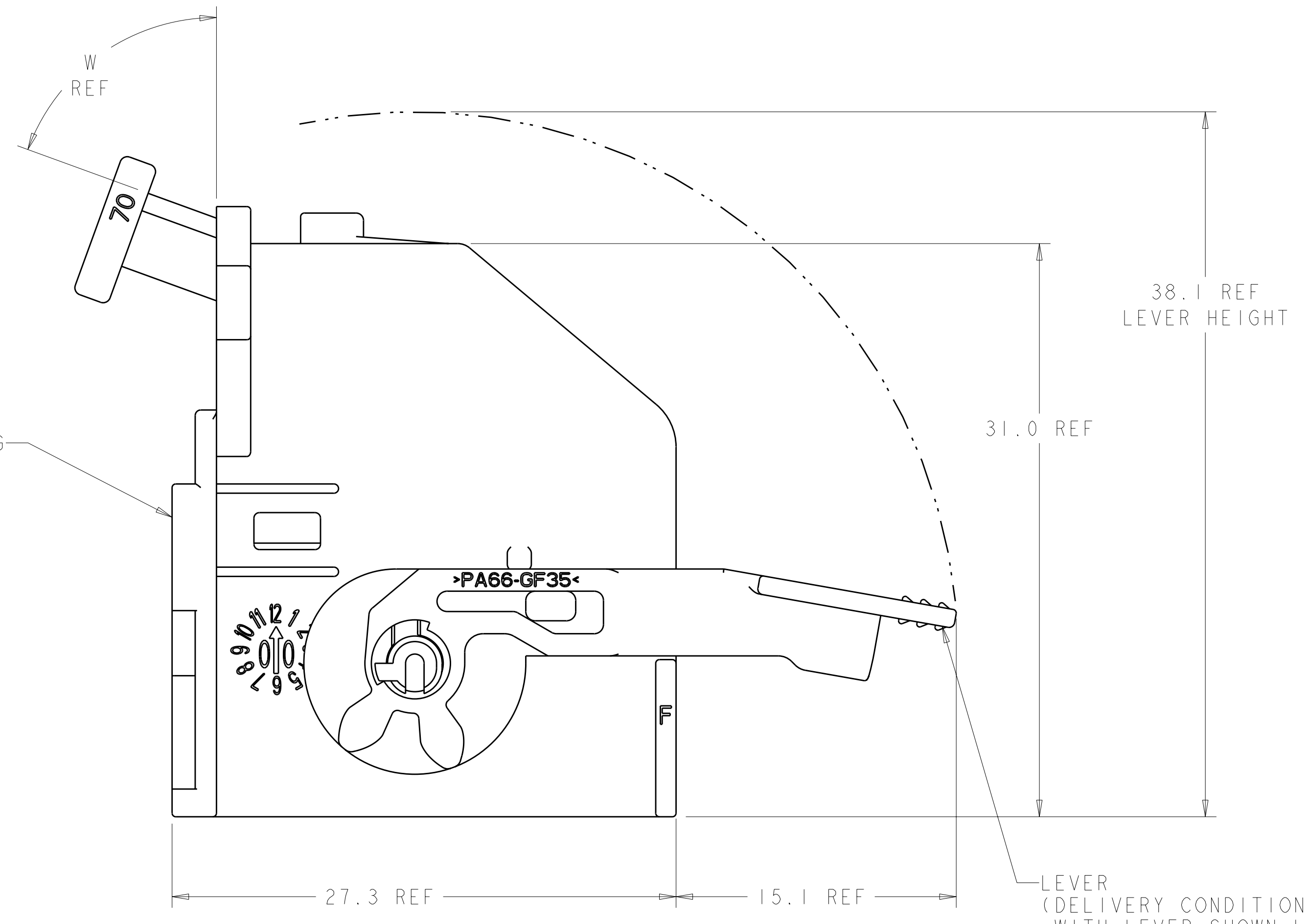
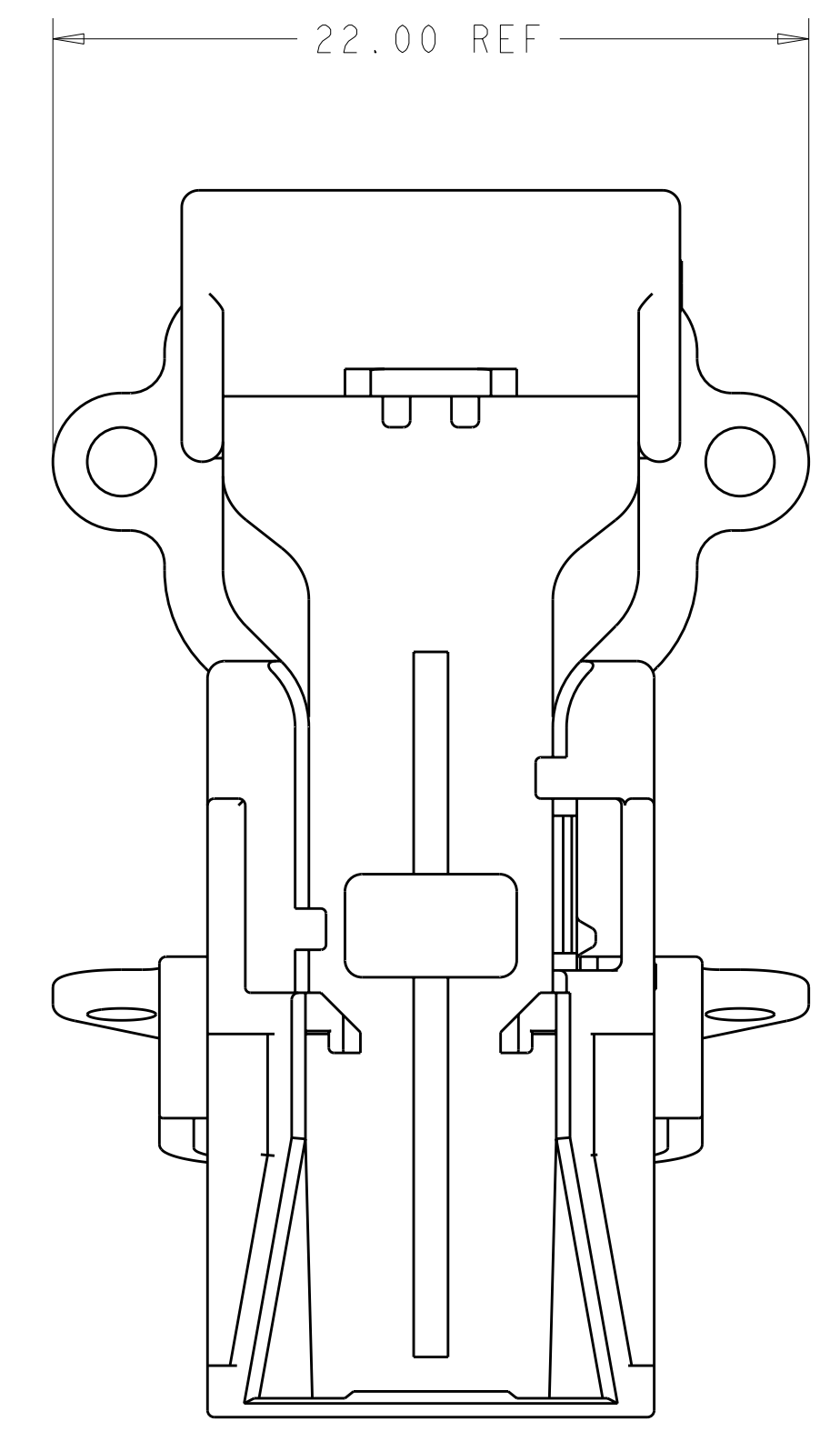

**KEYING OPTIONS
REFERENCE ONLY**

DIMENSIONS: mm TOLERANCES UNLESS OTHERWISE SPECIFIED: 9 PLC ±.1 1 PLC ±0.1 3 PLC ±0.05 4 PLC ±.1 ANGLES ±°		DIMENSIONS: mm TOLERANCES UNLESS OTHERWISE SPECIFIED: 9 PLC ±.1 1 PLC ±0.1 3 PLC ±0.05 4 PLC ±.1 ANGLES ±°		DIMENSIONS: mm TOLERANCES UNLESS OTHERWISE SPECIFIED: 9 PLC ±.1 1 PLC ±0.1 3 PLC ±0.05 4 PLC ±.1 ANGLES ±°	
MATERIAL: -		FINISH: -		DWN: C. CHAVEZ 04APR2002 CHK: S. TPBEY 04APR2002 APPD: - NAME: SHIELD ASSEMBLY, 18 POSITION, 0.64MM LEVER ASSIST CONNECTOR SIZE: A1 CAGE CODE: 00779 DRAWING NO: I-1326132 RESTRICTED TO: - CUSTOMER DRAWING: -	

LOC	DIST	REV	DATE	BY	APPD
FX	00				

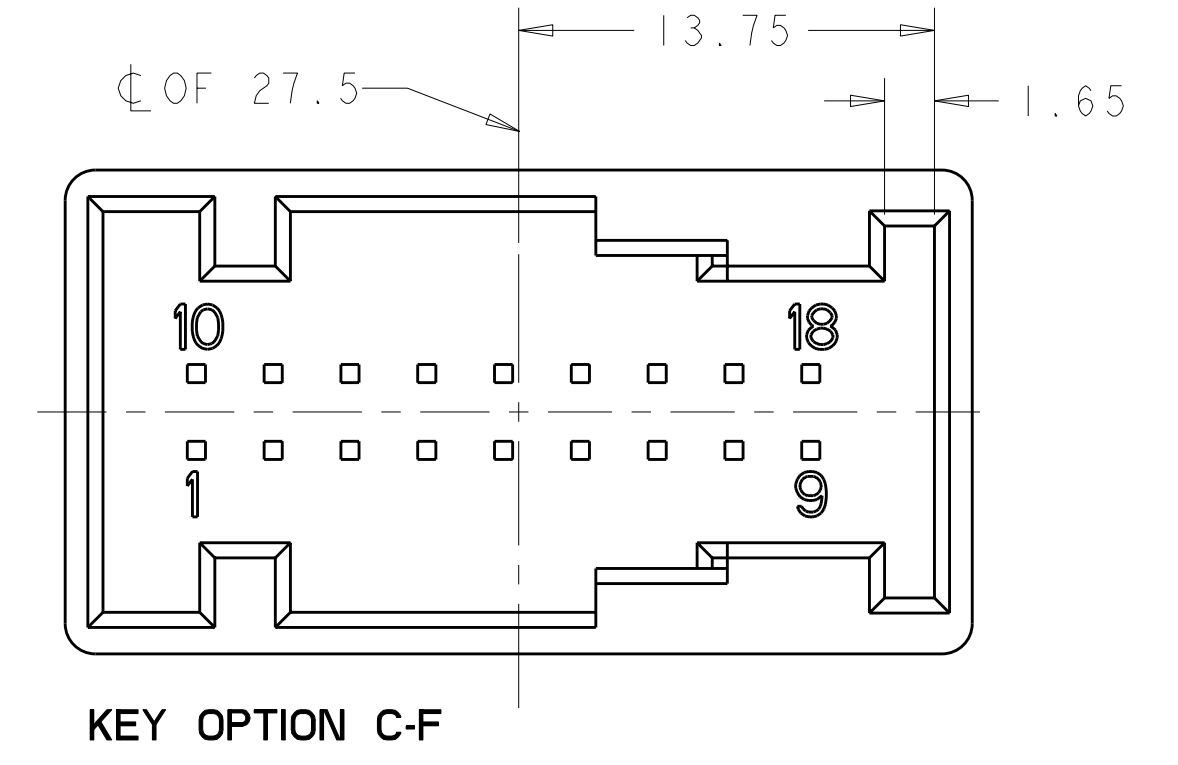
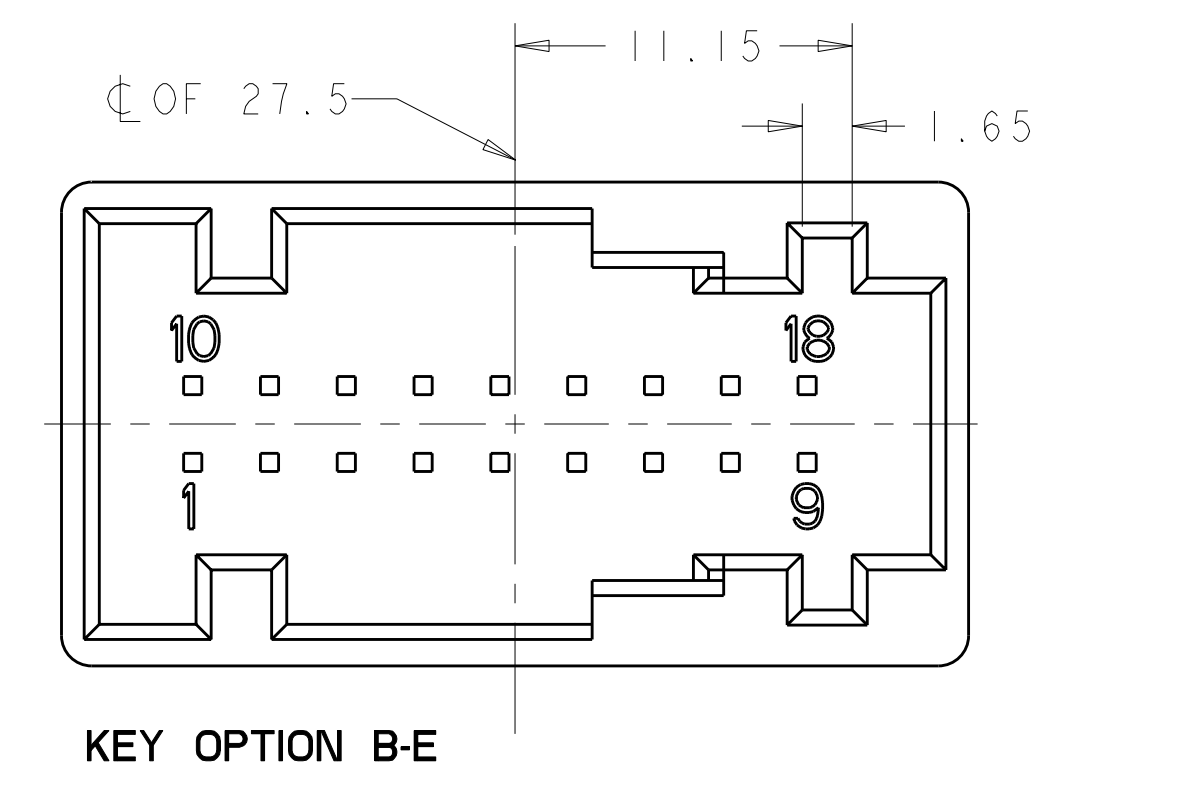
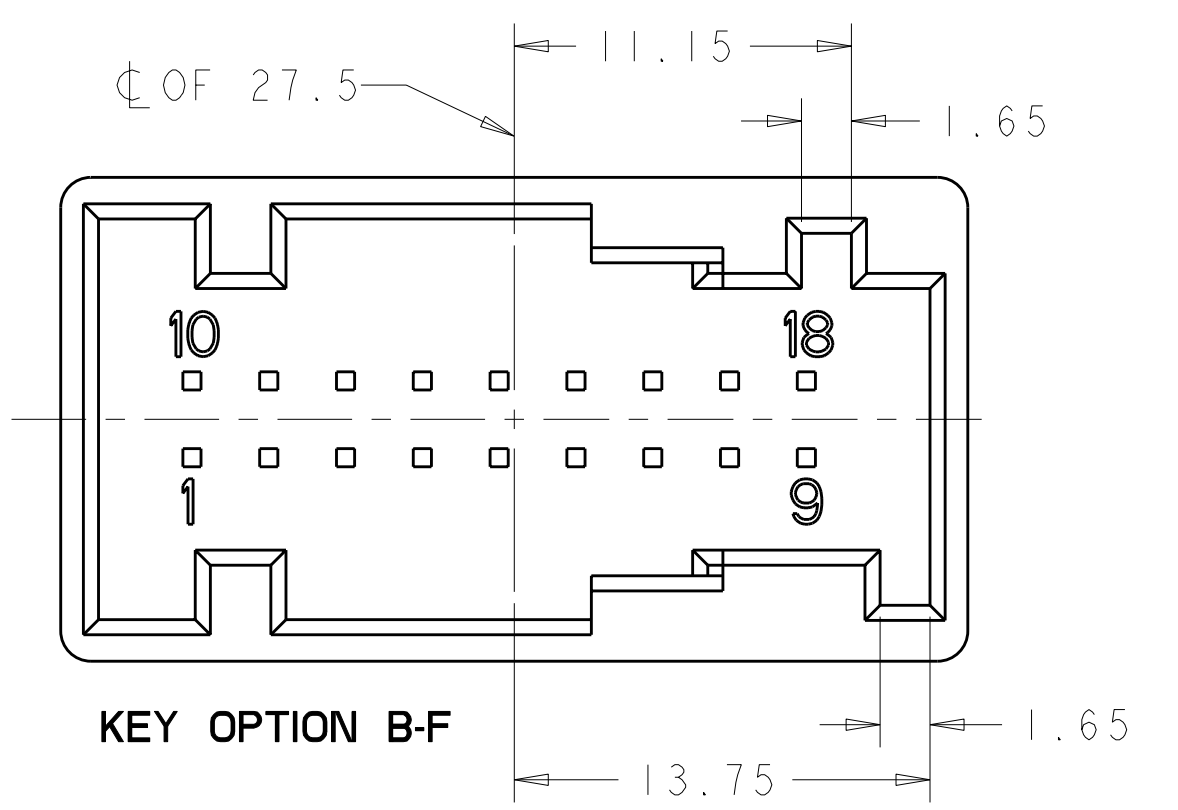
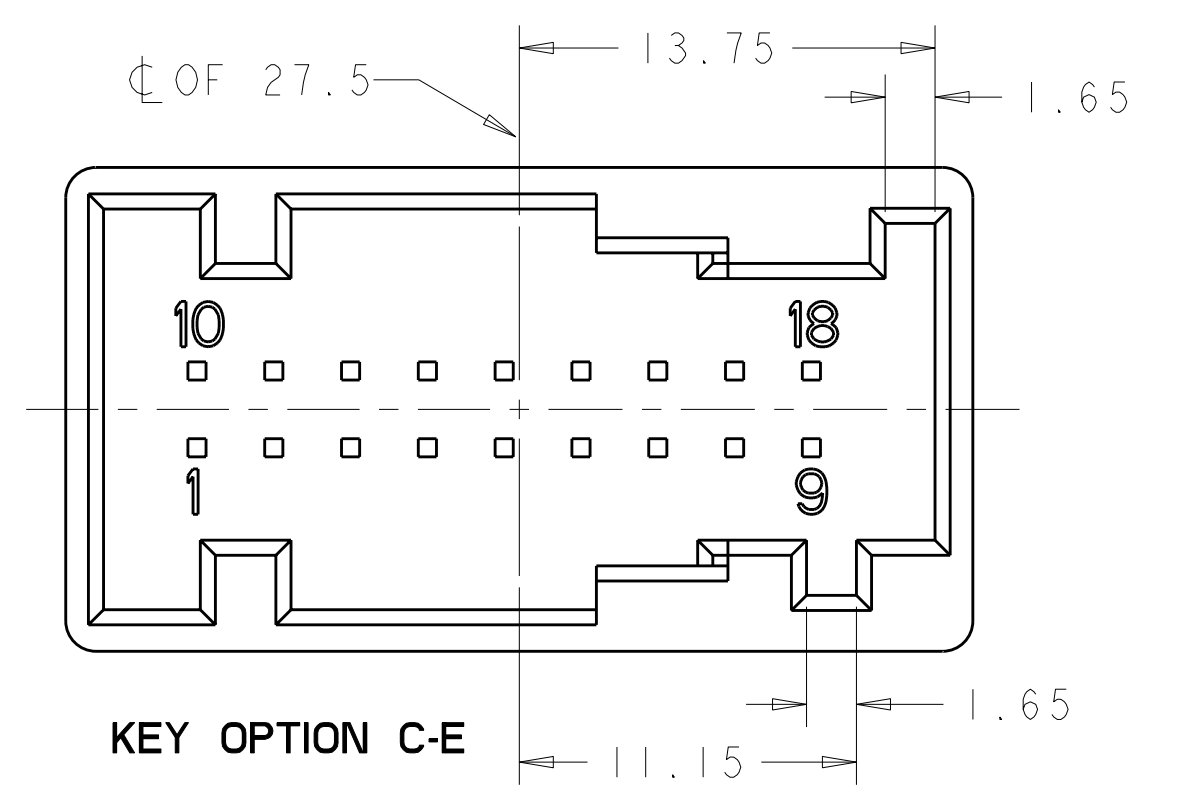
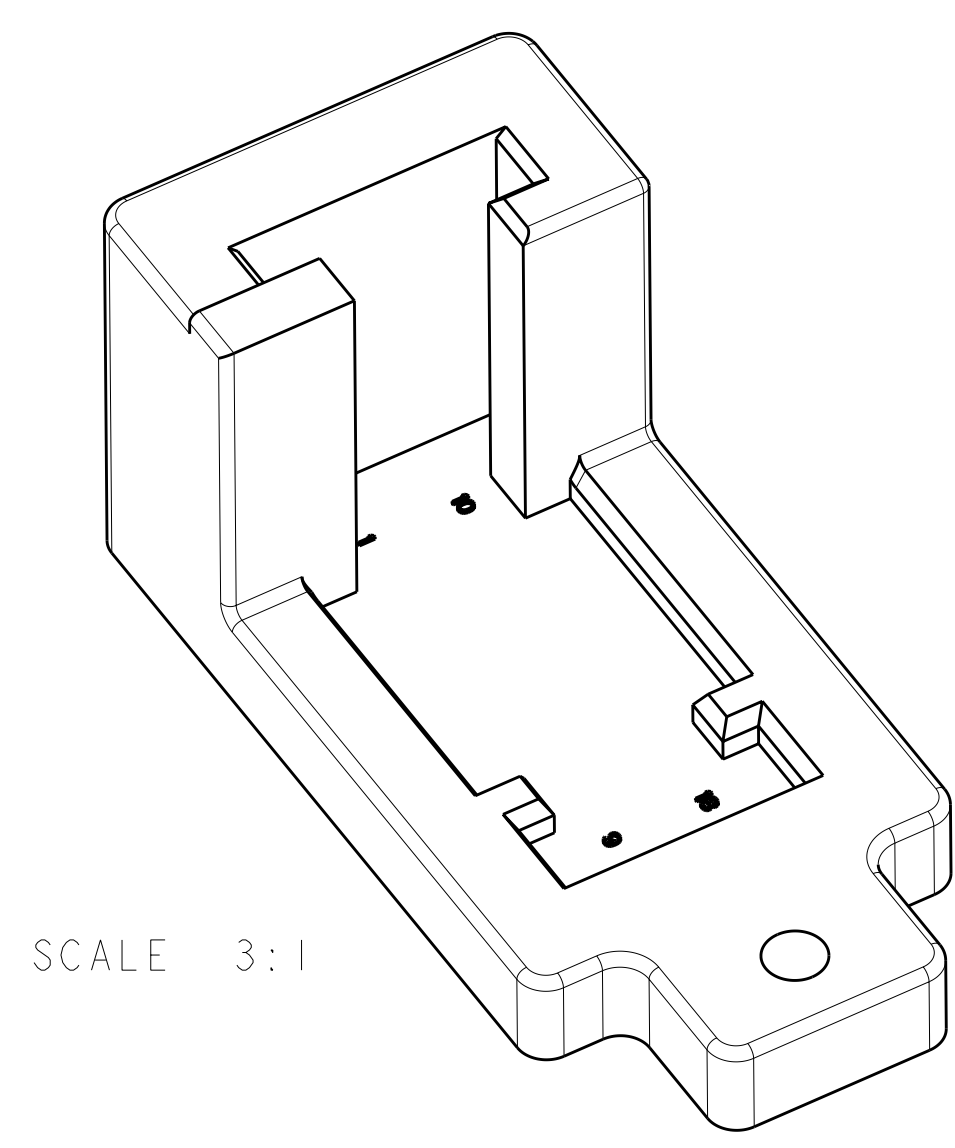
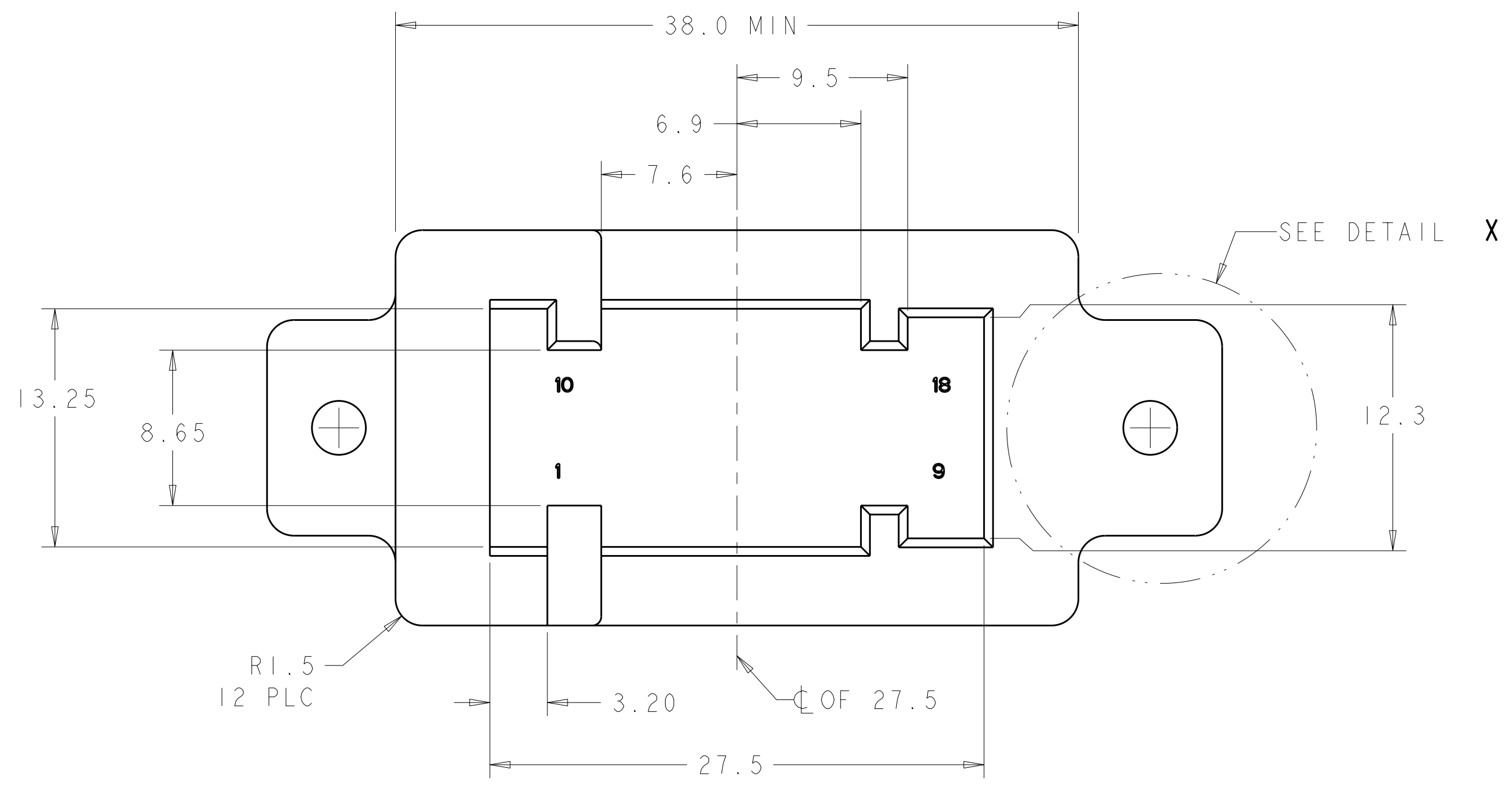

KEYING OPTIONS

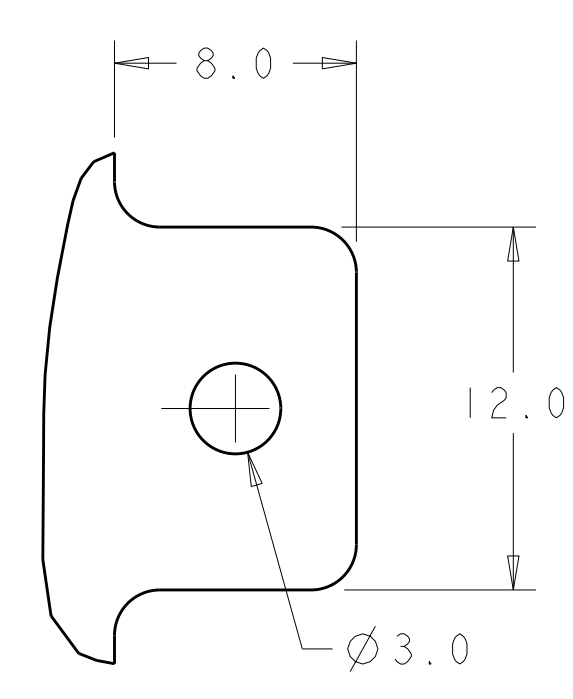
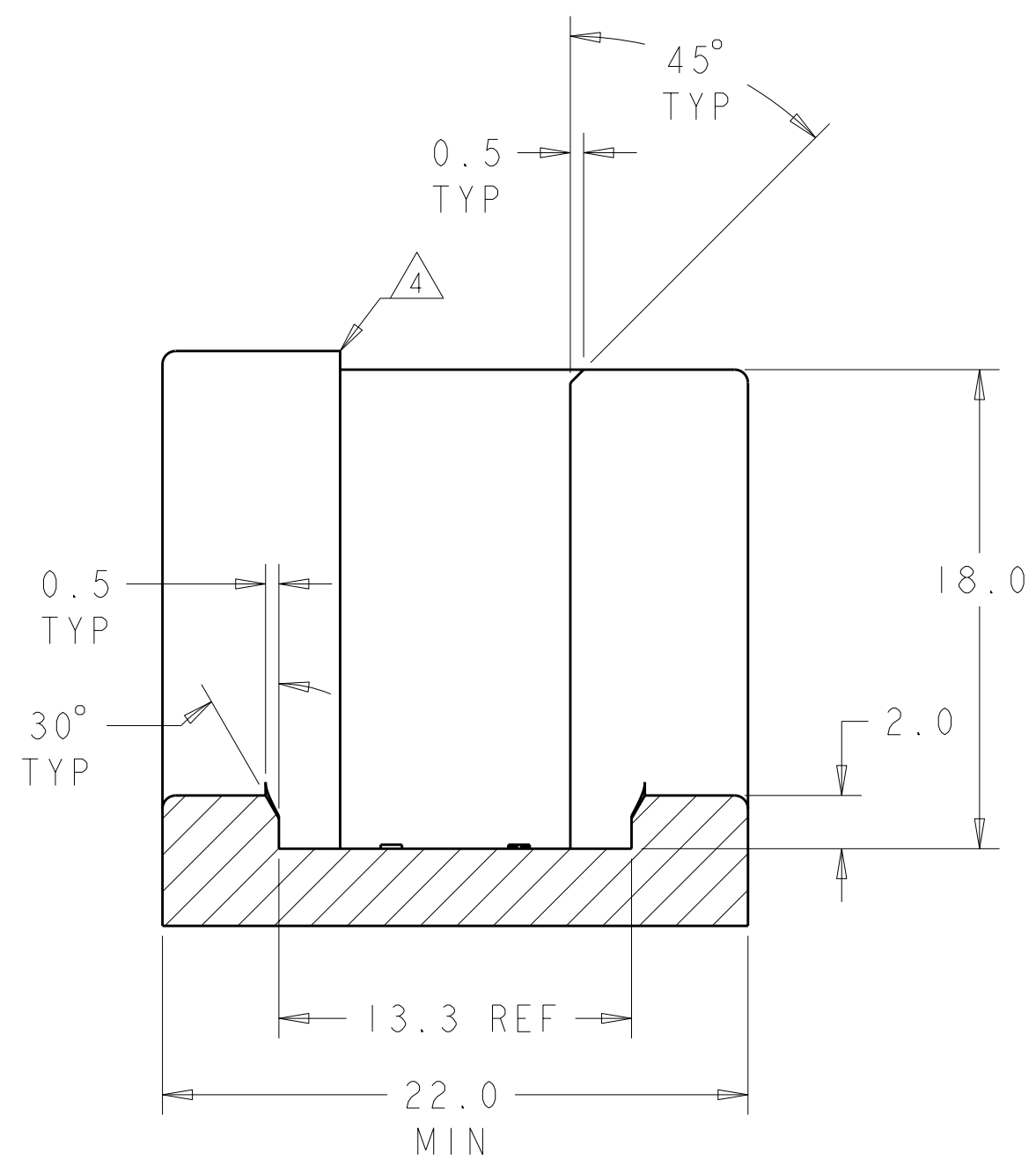
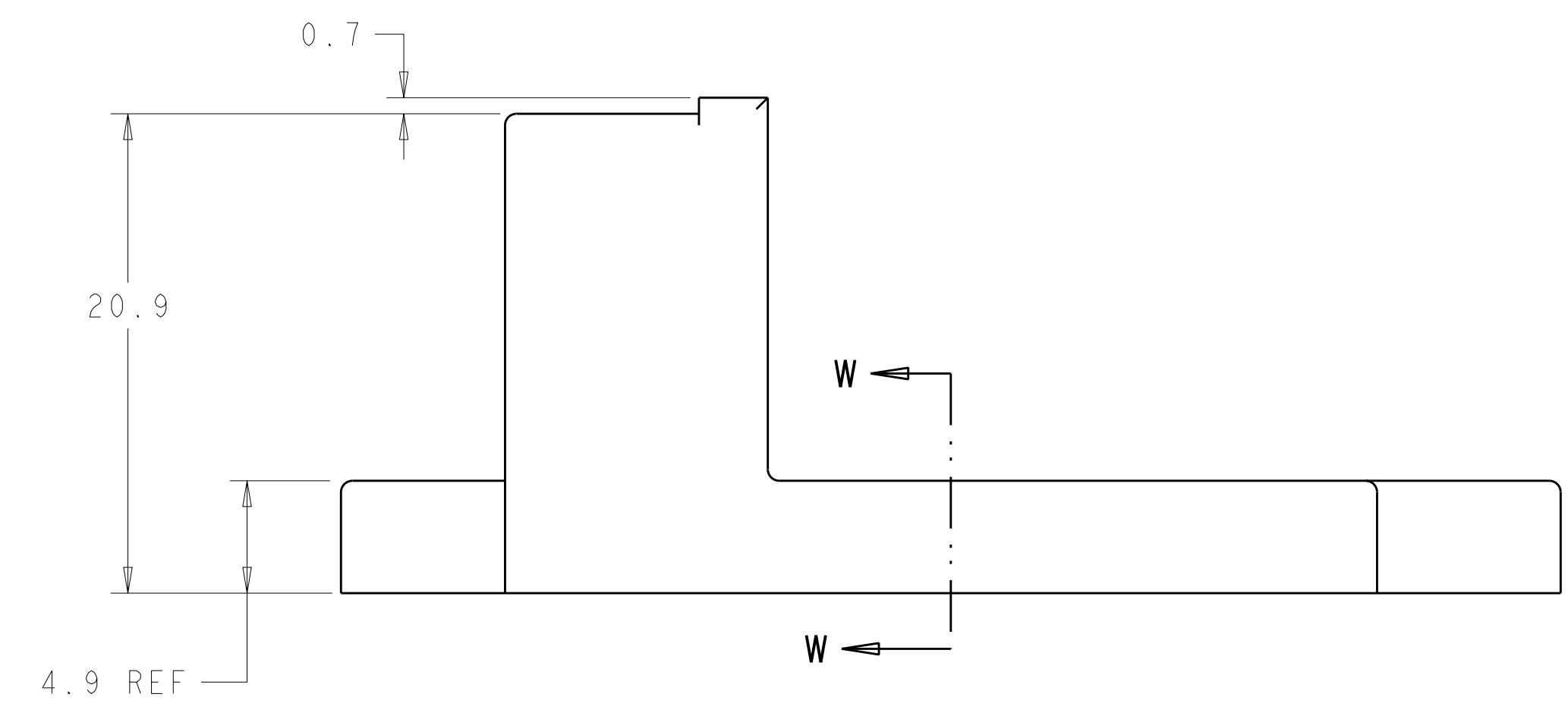

18 POSITION CONNECTOR FIXTURE
 (SHOWN WITH CLEARANCE FOR ALL KEY OPTIONS)

- CONNECTOR FIXTURE SHOULD BE USED TO VERIFY THE RECEPTACLE CARRIER IS PROPERLY SEATED AND LOCKED INTO THE SHIELD ASSEMBLY. THE CONNECTOR WILL NOT FULLY MATE TO THE FIXTURE IF THE RECEPTACLE CARRIER IS OUT OF POSITION.
- RECOMMEND USING A SENSING DEVICE FOR VERIFYING FULLY MATED CONNECTORS. SUCH A DEVICE IS UP TO THE CUSTOMERS DISCRETION.
- RECOMMENDED MATERIAL: HARDEND STEEL
- NO RADII OR CHAMFER PERMITTED IN SPECIFIED AREA. MUST MAINTAIN 90° EDGE.
- RADII TO BE 0.5 UNLESS OTHERWISE SPECIFIED.
- OPTIONAL CONSTRAINT FEATURE.

DIMENSIONS: mm 		TOLERANCES UNLESS OTHERWISE SPECIFIED: 9 PLC ± 1 PLC ±0.1 2 PLC ±0.05 3 PLC ± 4 PLC ± ANGLES ± FINISH ±		DWN C. CHAVEZ 04APR2002 CHK S. TPBEY 04APR2002 APVD - NAME PRODUCT SPEC APPLICATION SPEC WEIGHT CUSTOMER DRAWING	Tyco Electronics Harrisburg, PA 17105-3608 PRODUCT SPEC SHEET 2 OF 2 REV A1
--------------------	--	--	--	---	---

X-ON Electronics

Largest Supplier of Electrical and Electronic Components

Click to view similar products for [Automotive Connectors](#) category:

Click to view products by [TE Connectivity](#) manufacturer:

Other Similar products are found below :

[003-018-000](#) [60403001](#) [60993906-B](#) [M902-2131](#) [M902-2161](#) [M902-2344](#) [72.330.1035.1](#) [73.353.4028.0](#) [F119300-B](#) [F166900](#) [F258300-B](#)
[F358300-B](#) [F407400](#) [F444110](#) [F487000](#) [F509500B-B](#) [827153-1](#) [8N1515-32-24P](#) [9-1326729-8](#) [925474-1](#) [928905-1](#) [964562-4](#) [968782-1](#)
[GT17SA-8DS-HU](#) [98891-1012](#) [98947-1016](#) [12004147](#) [12004475-L](#) [12010290](#) [12010309-B](#) [12015454](#) [12020219-B](#) [12041318-B](#) [12052225-](#)
[L](#) [12052466](#) [12064869](#) [12004327-B](#) [12015308](#) [12015384](#) [12015909](#) [1-21030-1](#) [12041254](#) [12041318](#) [12047946-B](#) [12047957](#) [12047957-L](#)
[12059473](#) [12066261](#) [12110546](#) [12110546-B](#)