

SCALE 2:1

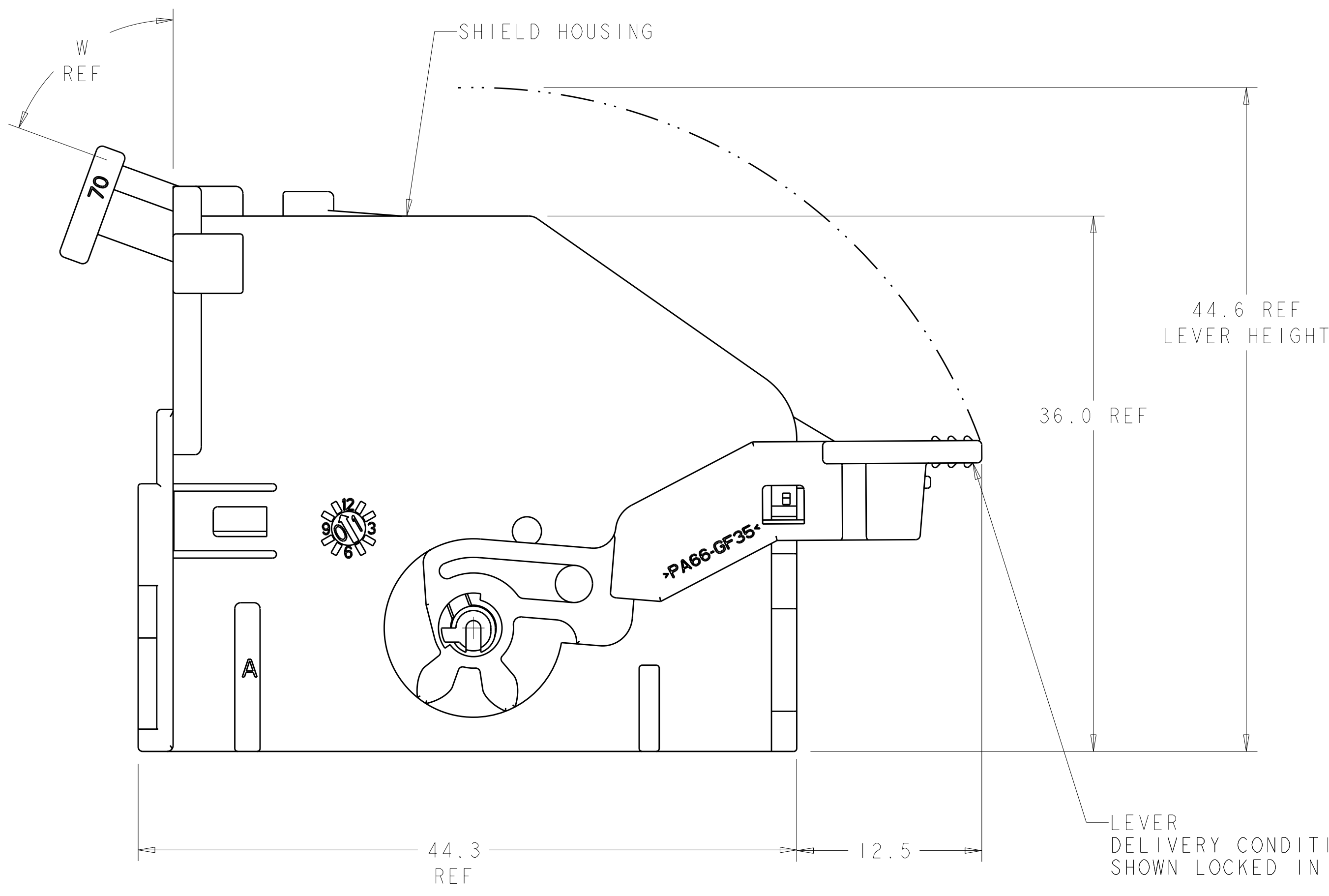

- 1. MATERIAL: SHIELD - 35% GLASS REINFORCED NYLON, SEE TABLE BELOW FOR COLOR.  
LEVER - 35% GLASS REINFORCED NYLON, COLOR GRAY.
- 2. REFERENCE: RECEPTACLE HOUSING 1326227-1 USED WITH THIS ASSEMBLY.
- 3. REFER TO INSTRUCTION SHEET 408-8662 FOR PRODUCT ASSEMBLY AND DISASSEMBLY PROCEDURES.
- 4. REFER TO USCAR-2 REV 3 APRIL 2001 FOR PRODUCT SPECIFICATIONS.
- 5. REFER TO DRAWING NO. AUAUT00000-2962-0486 FOR INTERFACE DETAILS.

LOC	DIST	REV	DATE	BY	CHKD	APPD
FX	00	0	20DEC2002	SPT	AME	
		A	16APR2003	RGV	AME	
		A1	28MAY2010	VSS	CS	

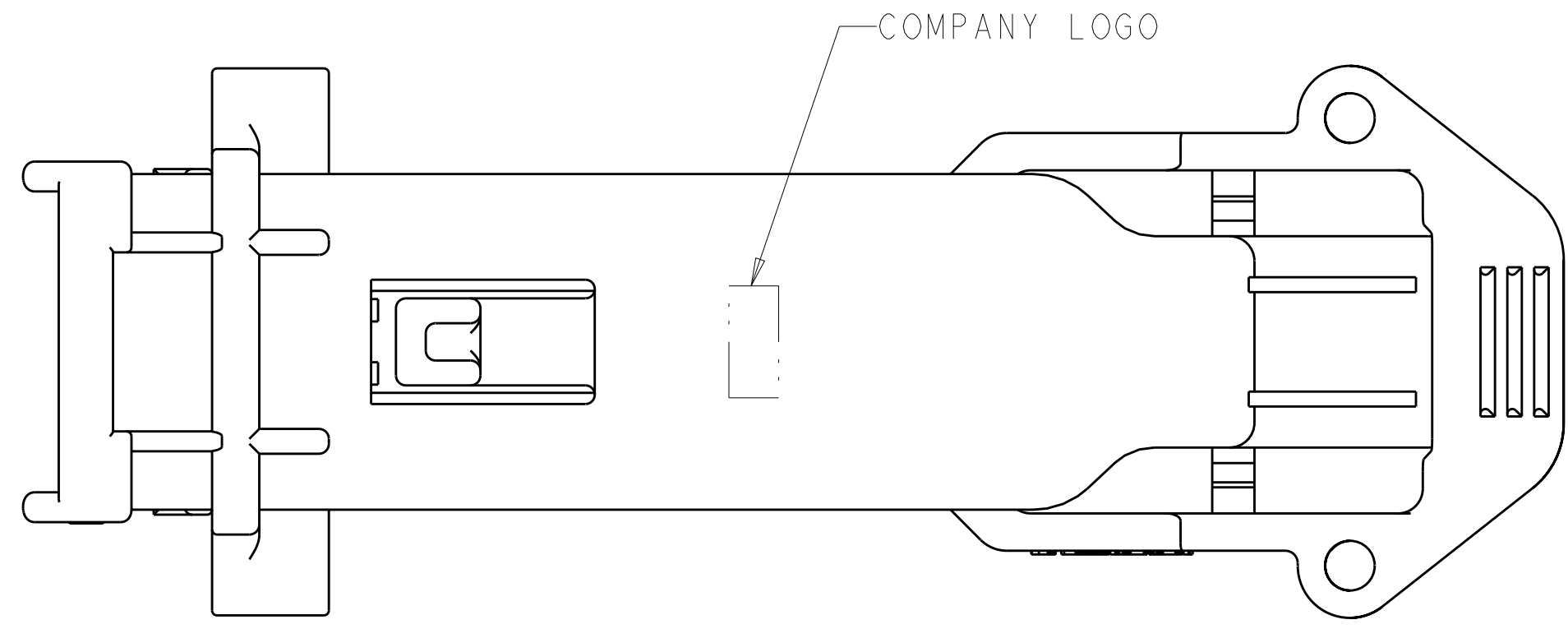
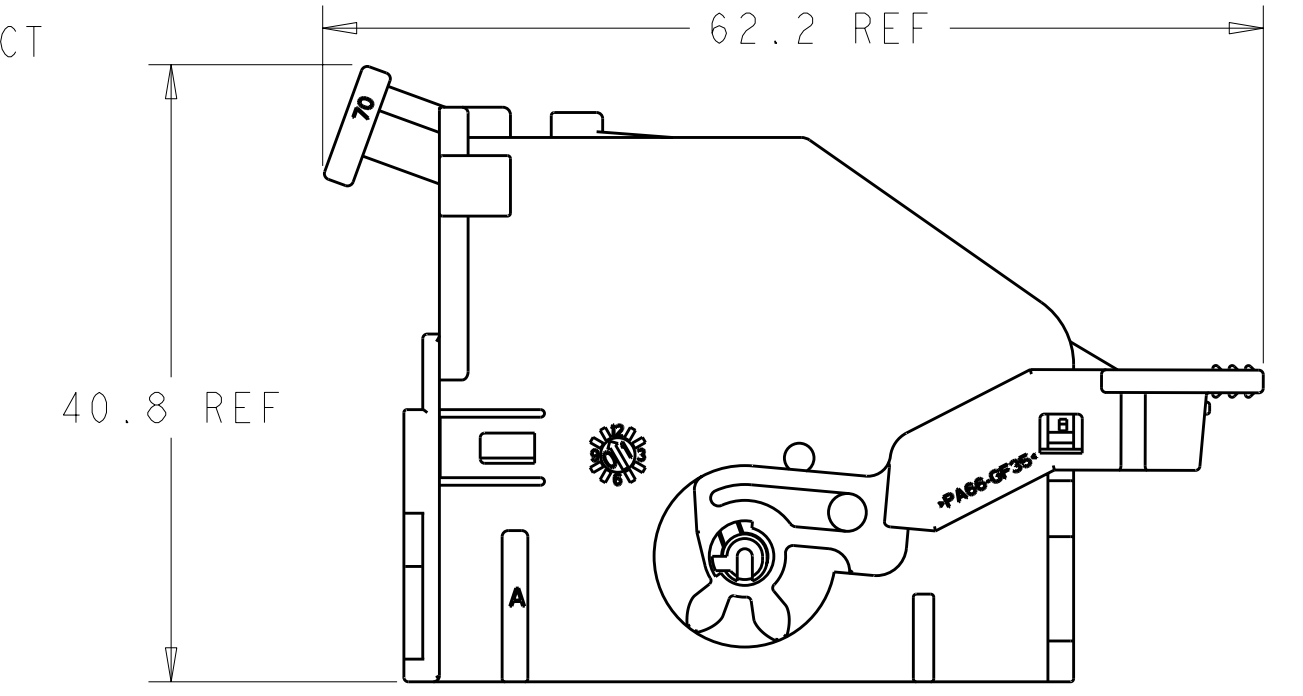

70° WIRE EXIT  
SCALE 2:1

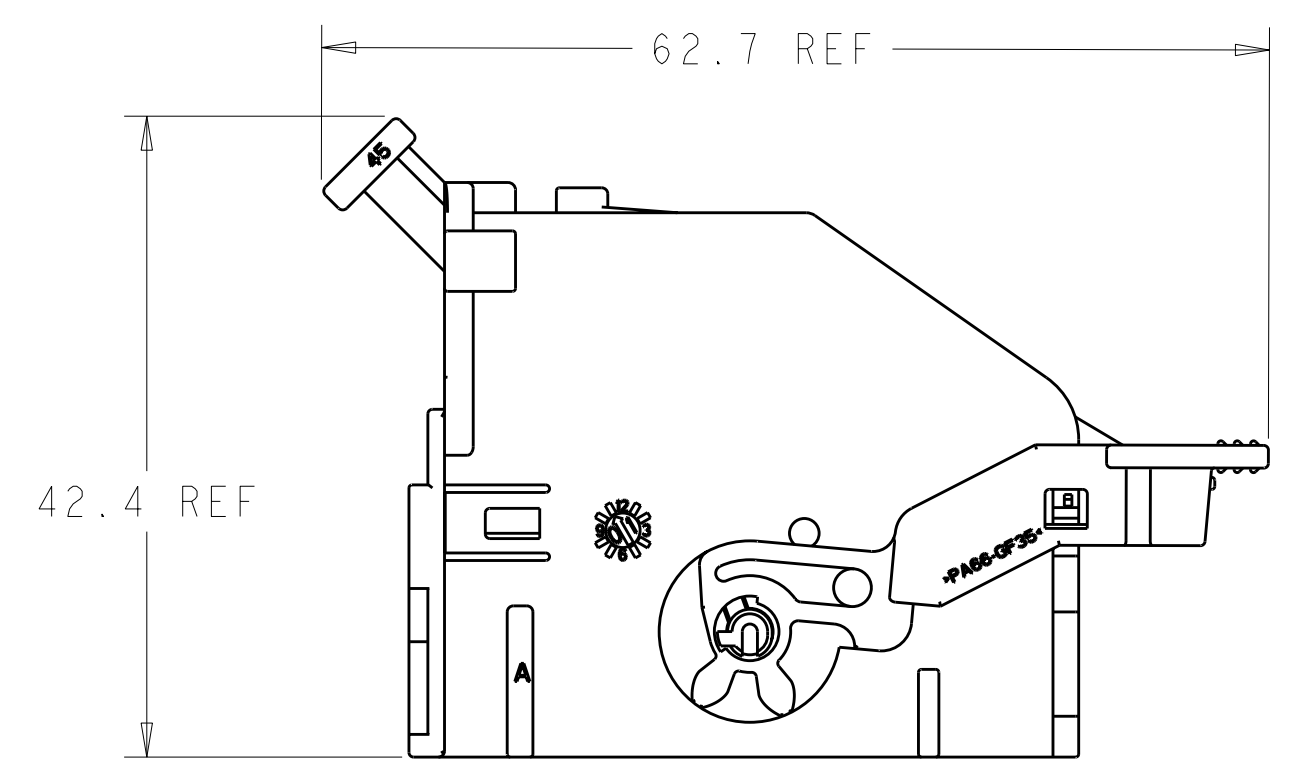

45° WIRE EXIT  
SCALE 2:1

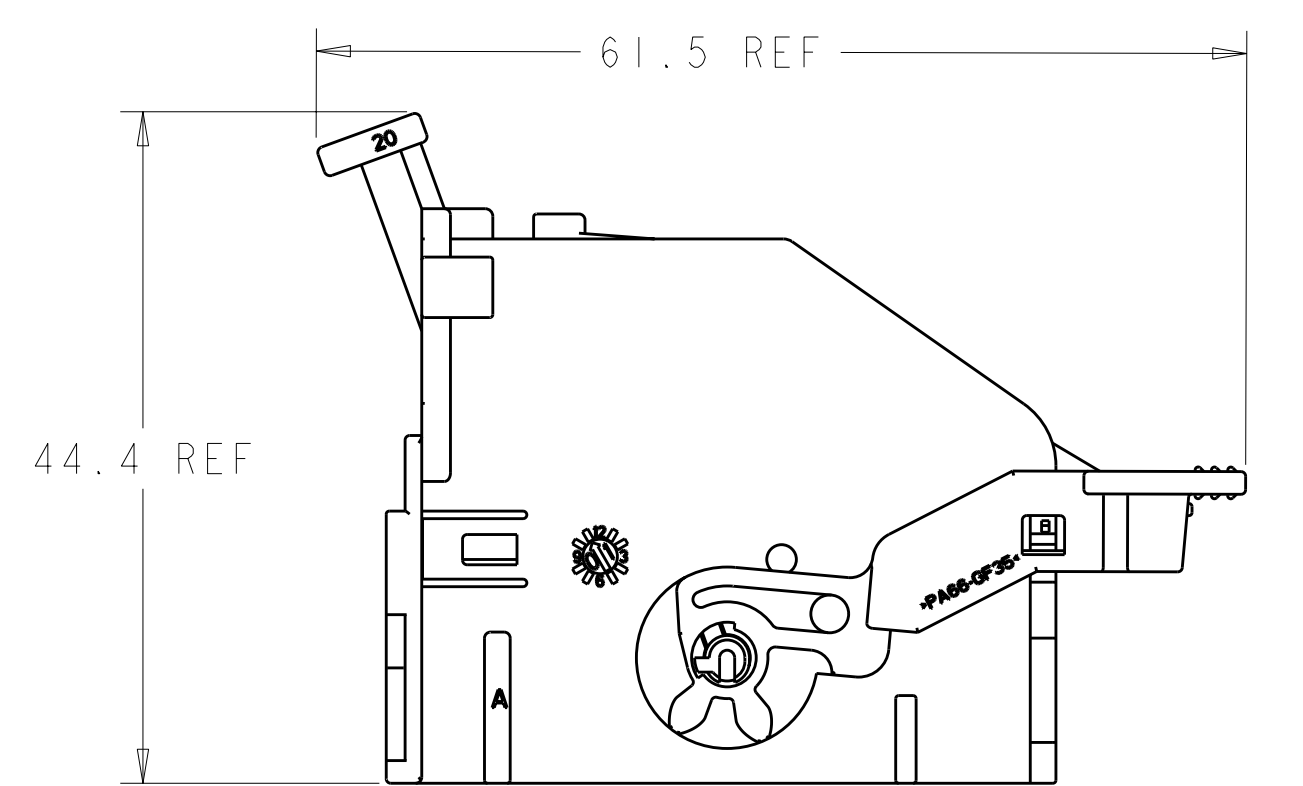

20° WIRE EXIT  
SCALE 2:1

**WIRE EXIT OPTIONS  
REFERENCE ONLY**

DIM	W	COLOR	KEYING OPT.	PART NUMBER
70°	BLACK	A		1-1326226-0
20°	BLACK	C		1326226-9
20°	BLUE	B		1326226-8
20°	GREY	A		1326226-7
45°	BLACK	C		1326226-6
45°	BLUE	B		1326226-5
45°	GREY	A		1326226-4
70°	BLACK	C		1326226-3
70°	BLUE	B		1326226-2
70°	GREY	A		1326226-1

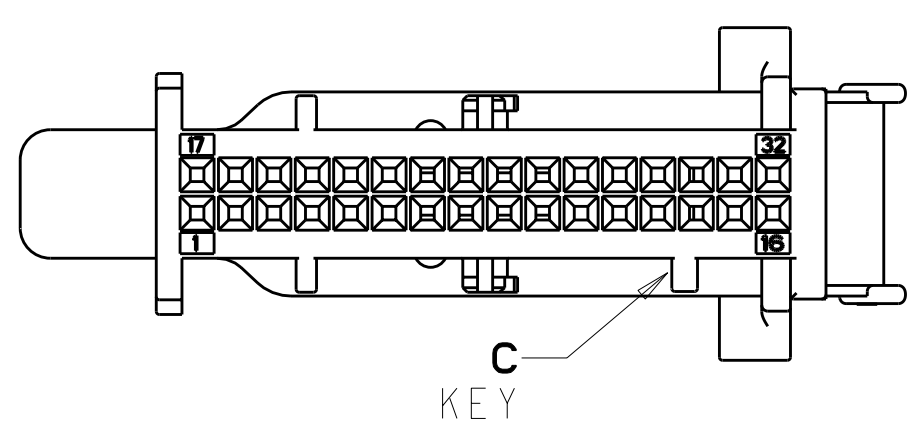
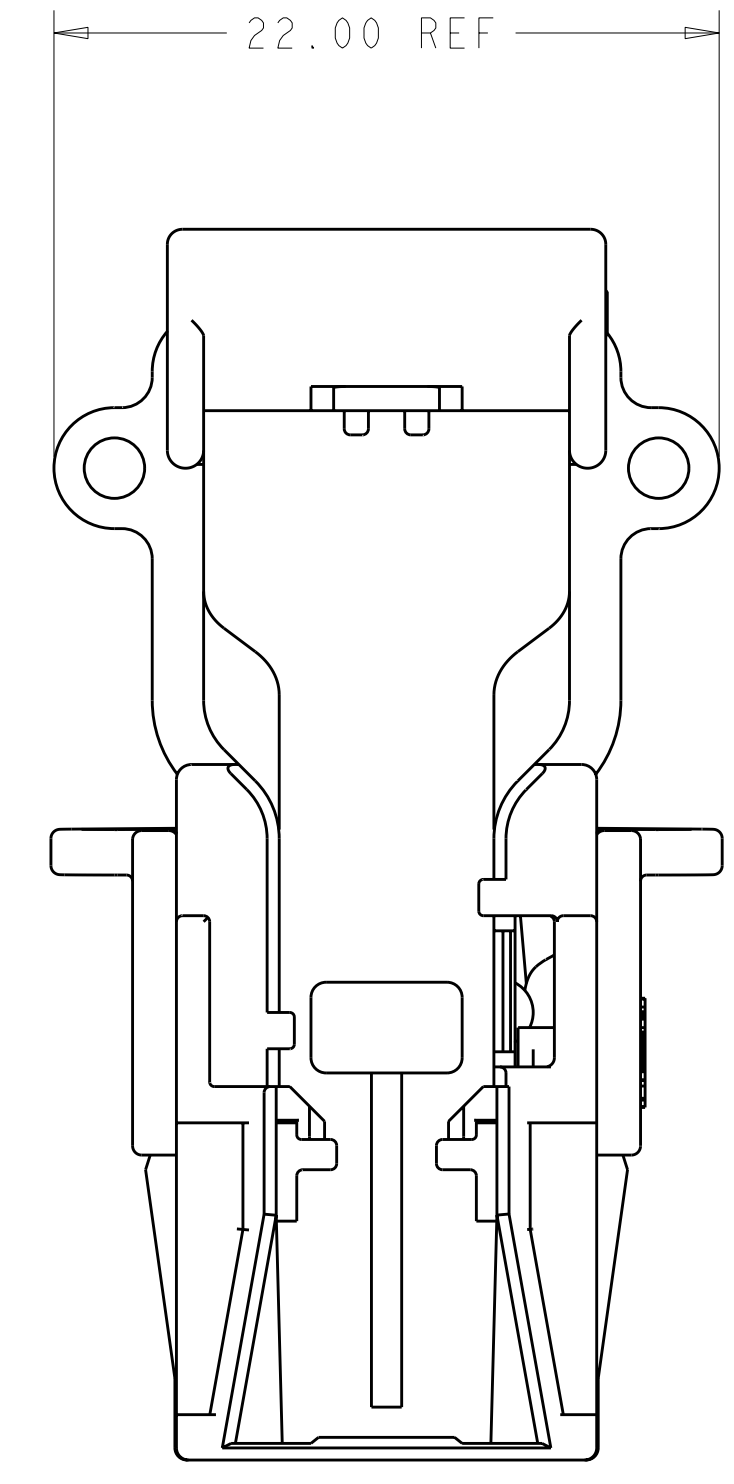

KEY C SHOWN

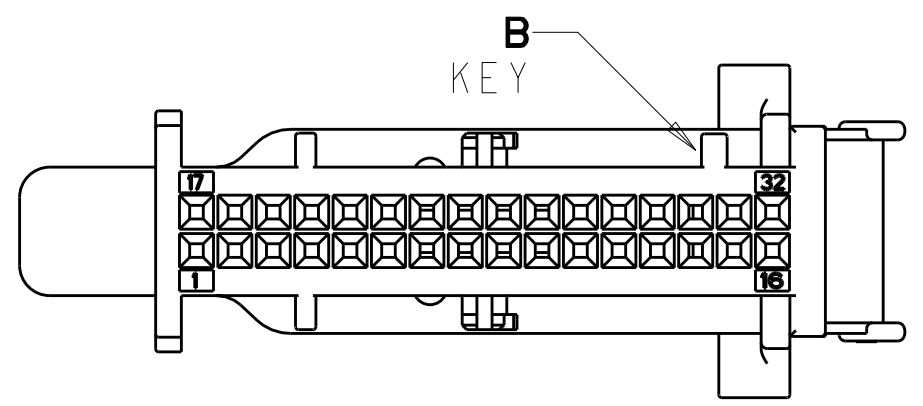

KEY B SHOWN

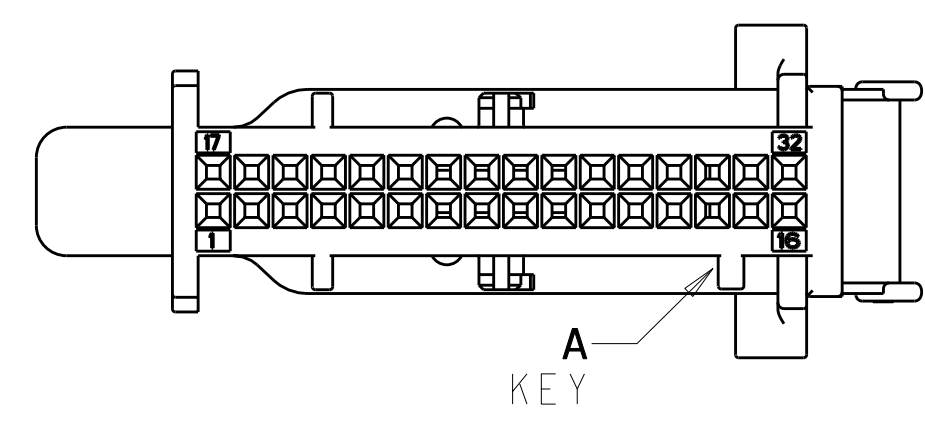

KEY A SHOWN

**KEYING OPTIONS  
REFERENCE ONLY**

DIMENSIONS: mm 		TOLERANCES UNLESS OTHERWISE SPECIFIED: 9 PLC ± 1 PLC ±0.2 3 PLC ±0.05 4 PLC ± ANGLES ± FINISH #1		DWN: W. HOELSCHER 04SEP2001 CHK: S. TOBEY 04SEP2001 APPD: S. TOBEY 04SEP2001 PRODUCT SPEC APPLICATION SPEC WEIGHT CUSTOMER DRAWING		Tyco Electronics Harrisburg, PA 17105-3608 SHIELD ASSEMBLY 32 POSITION 0.64mm LAC SIZE: CAGE CODE: DRAWING NO: 00779 SCALE: 3:1 SHEET 1 OF 2 REV A1	
-----------------------	--	--	--	--	--	---	--

LOC	DIST	REV	DATE	BY	APPD
FX	00				
		DESCRIPTION	DATE	BY	APPD
		SEE SHEET 1			

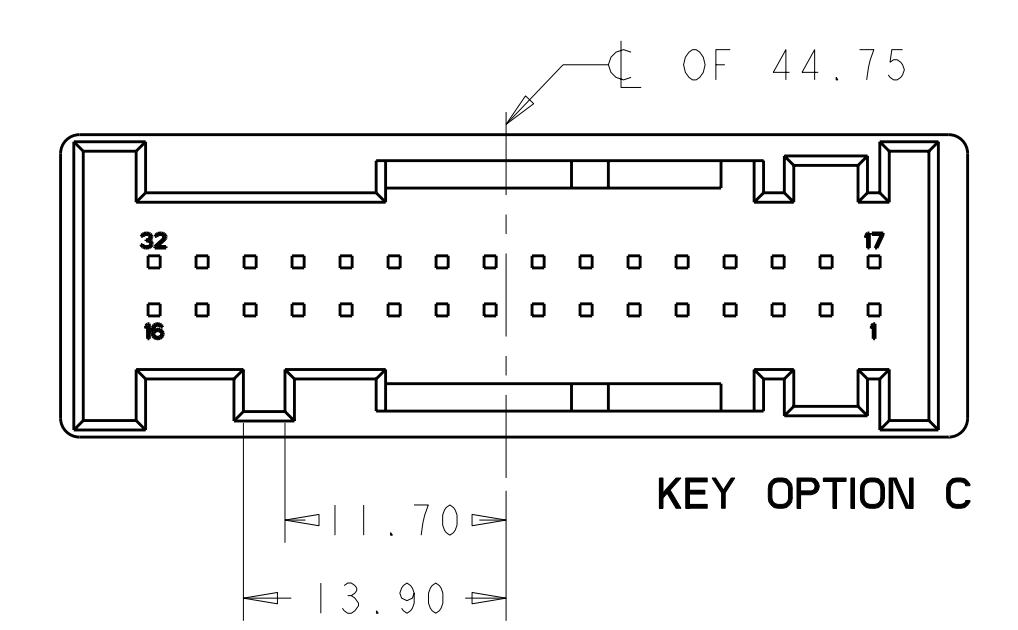
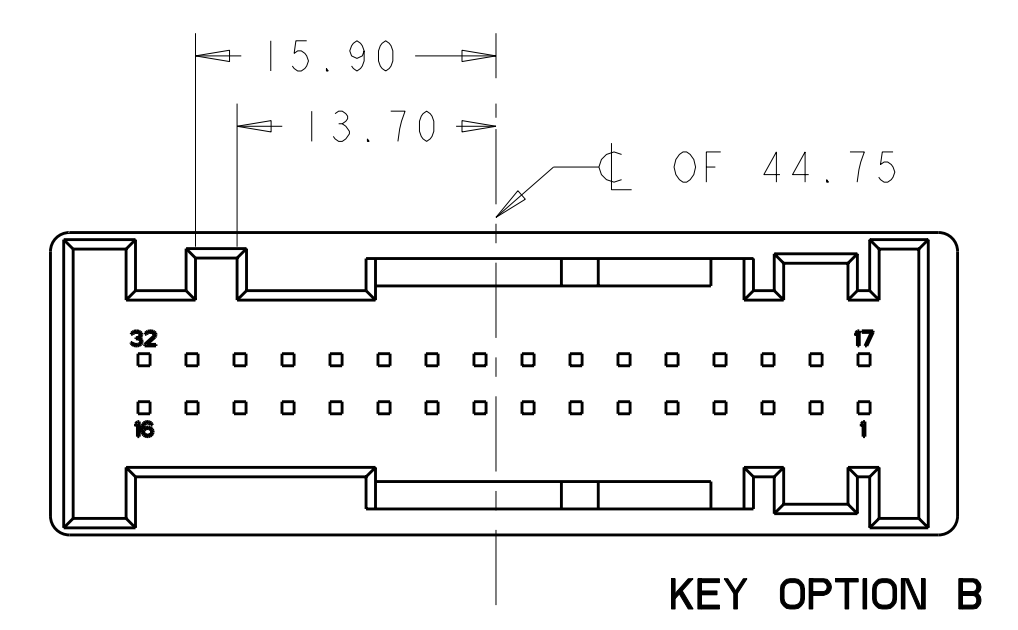
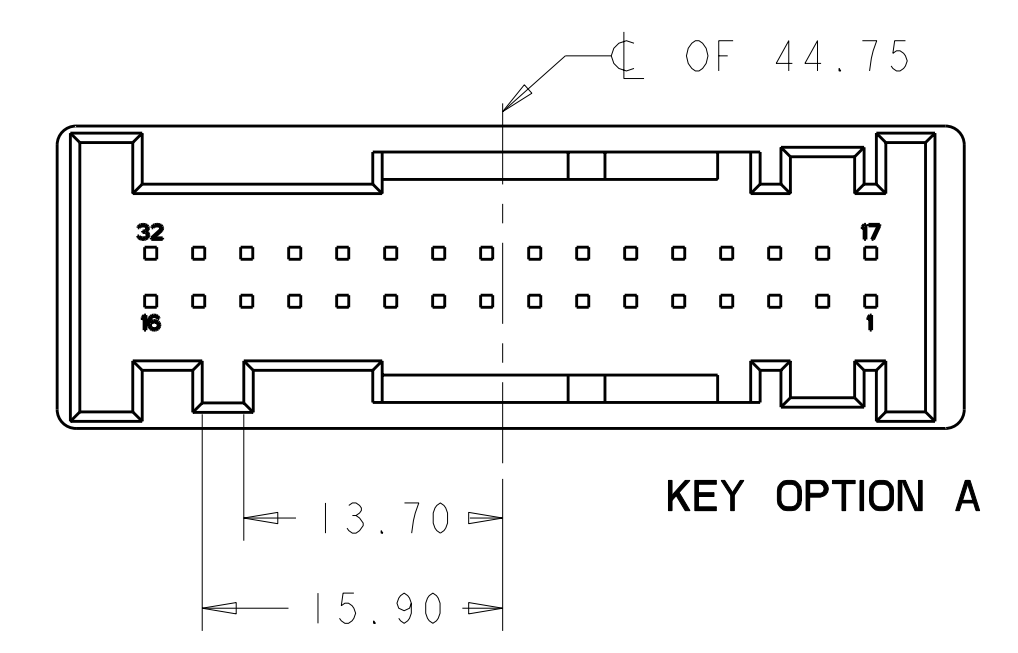
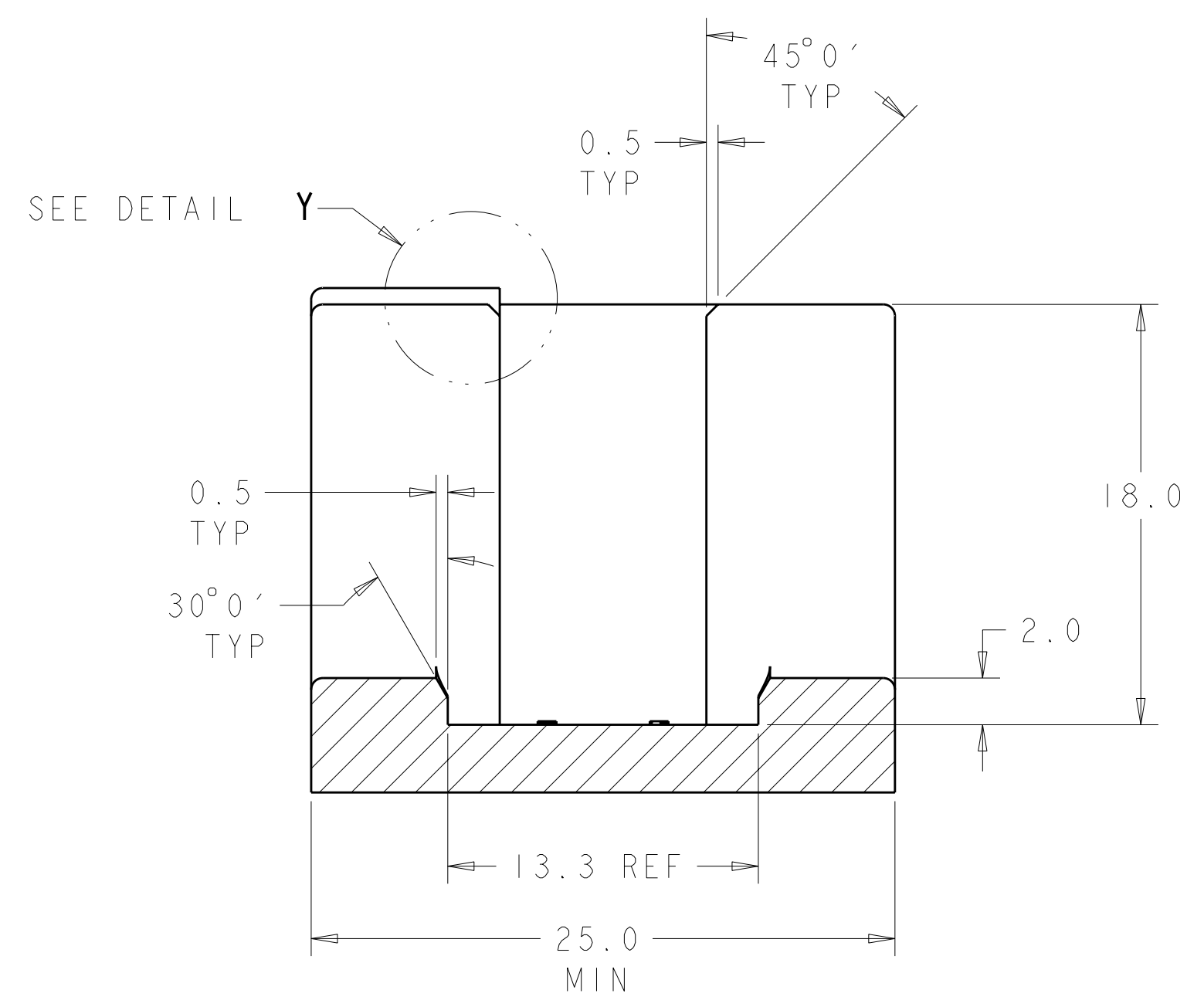
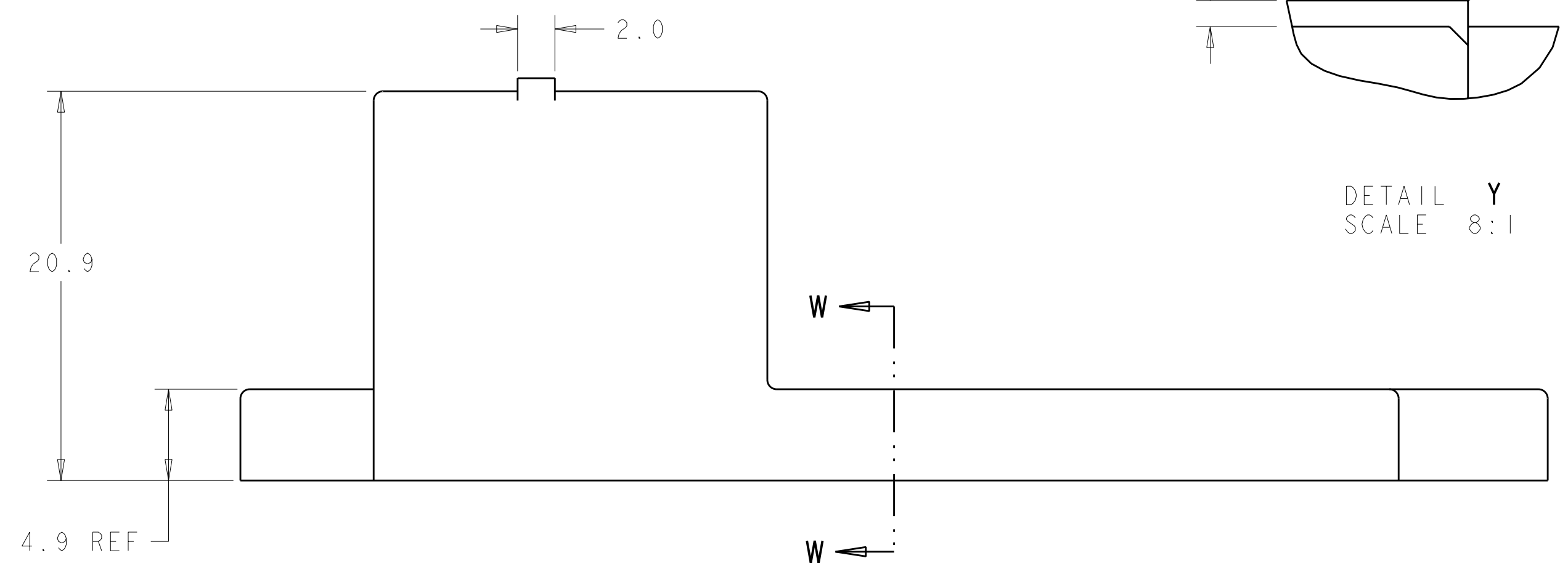
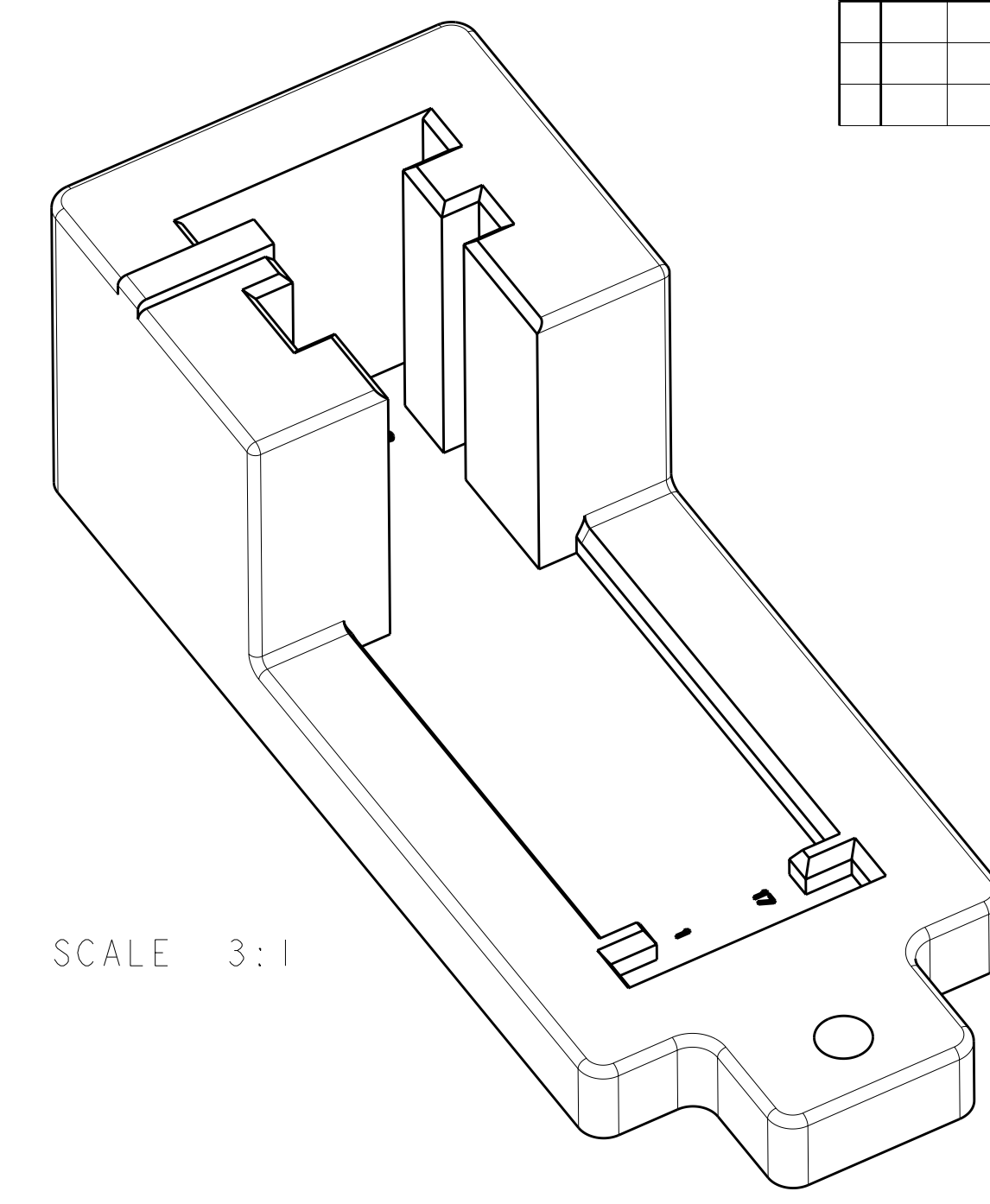
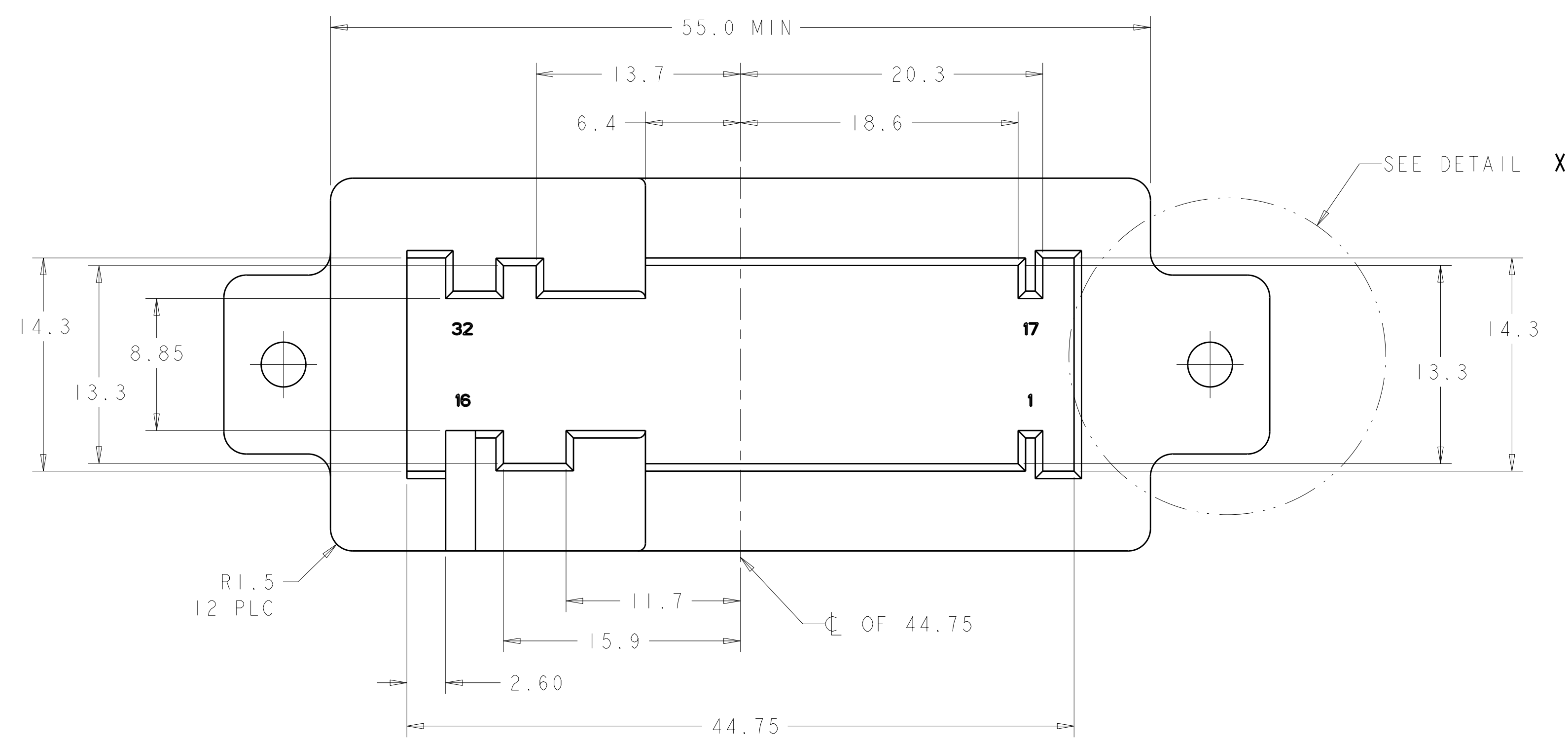

**32 POSITION CONNECTOR FIXTURE**  
 (SHOWN WITH CLEARANCE FOR ALL KEY OPTIONS)

**KEYING OPTIONS**

- CONNECTOR FIXTURE SHOULD BE USED TO VERIFY THE RECEPTACLE CARRIER IS PROPERLY SEATED AND LOCKED INTO THE SHIELD ASSEMBLY. THE CONNECTOR WILL NOT FULLY MATE TO THE FIXTURE IF THE RECEPTACLE CARRIER IS OUT OF POSITION.
- RECOMMEND USING A SENSING DEVICE FOR VERIFYING FULLY MATED CONNECTORS. SUCH A DEVICE IS UP TO THE CUSTOMERS DISCRETION.
- RECOMMENDED MATERIAL: HARDEND STEEL
- NO RADII OR CHAMFER PERMITTED IN SPECIFIED AREA. MUST MAINTAIN 90° EDGE.
- RADII TO BE 0.5 UNLESS OTHERWISE SPECIFIED.
- OPTIONAL CONSTRAINT FEATURE.

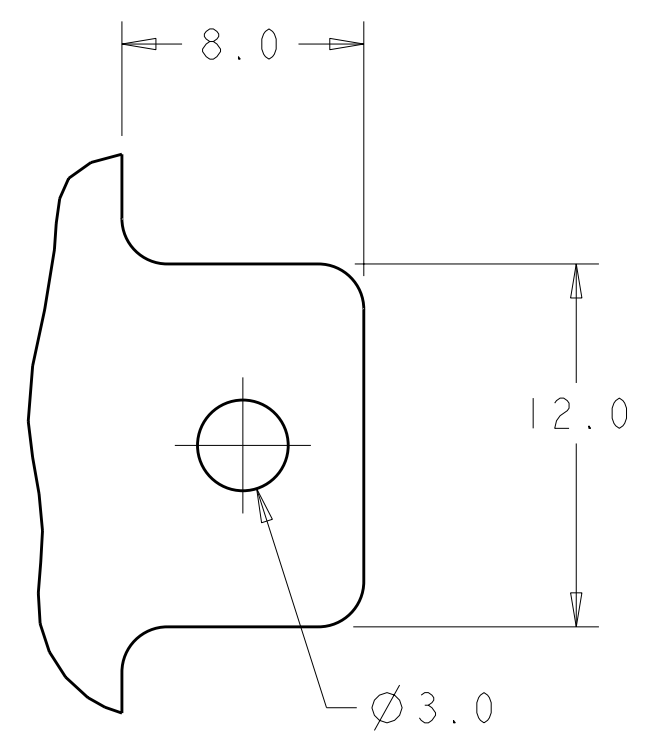

DIMENSIONS: mm 		TOLERANCES UNLESS OTHERWISE SPECIFIED: 0 PLC ± 1 PLC ±0.2 2 PLC ±0.05 3 PLC ± 4 PLC ± ANGLES ± FINISH ±#1		DWN W. HOELSCHER 04SEP2001 CHK S. TOBEY 04SEP2001 APVD S. TOBEY 04SEP2001 NAME PRODUCT SPEC APPLICATION SPEC WEIGHT CUSTOMER DRAWING		Tyco Electronics Tyco Electronics Harrisburg, PA 17105-3608 SHIELD ASSEMBLY 32 POSITION 0.64mm LAC SIZE CAGE CODE DRAWING NO. RESTRICTED TO A11 00779 C=1326226 SCALE 5:2 SHEET 2 OF 2 REV A1	
-----------------------	--	--	--	---	--	---	--

## X-ON Electronics

Largest Supplier of Electrical and Electronic Components

*Click to view similar products for [Automotive Connectors](#) category:*

*Click to view products by [TE Connectivity](#) manufacturer:*

Other Similar products are found below :

[003-018-000](#) [60403001](#) [60993906-B](#) [M902-2131](#) [M902-2161](#) [M902-2344](#) [72.330.1035.1](#) [73.353.4028.0](#) [F119300-B](#) [F166900](#) [F258300-B](#)  
[F358300-B](#) [F407400](#) [F444110](#) [F487000](#) [F509500B-B](#) [827153-1](#) [8N1515-32-24P](#) [9-1326729-8](#) [925474-1](#) [928905-1](#) [964562-4](#) [968782-1](#)  
[GT17SA-8DS-HU](#) [98891-1012](#) [98947-1016](#) [12004147](#) [12004475-L](#) [12010290](#) [12010309-B](#) [12015454](#) [12020219-B](#) [12041318-B](#) [12052225-](#)  
[L](#) [12052466](#) [12064869](#) [12004327-B](#) [12015308](#) [12015384](#) [12015909](#) [1-21030-1](#) [12041254](#) [12041318](#) [12047946-B](#) [12047957](#) [12047957-L](#)  
[12059473](#) [12066261](#) [12110546](#) [12110546-B](#)