

THIS DRAWING IS UNPUBLISHED. RELEASED FOR PUBLICATION  
 © COPYRIGHT - By - ALL RIGHTS RESERVED.

REVISIONS				
P	LTR	DESCRIPTION	DATE	APVD
B		UPDATE PER ECO-16-002588	24 FEB 16	CAS CAS

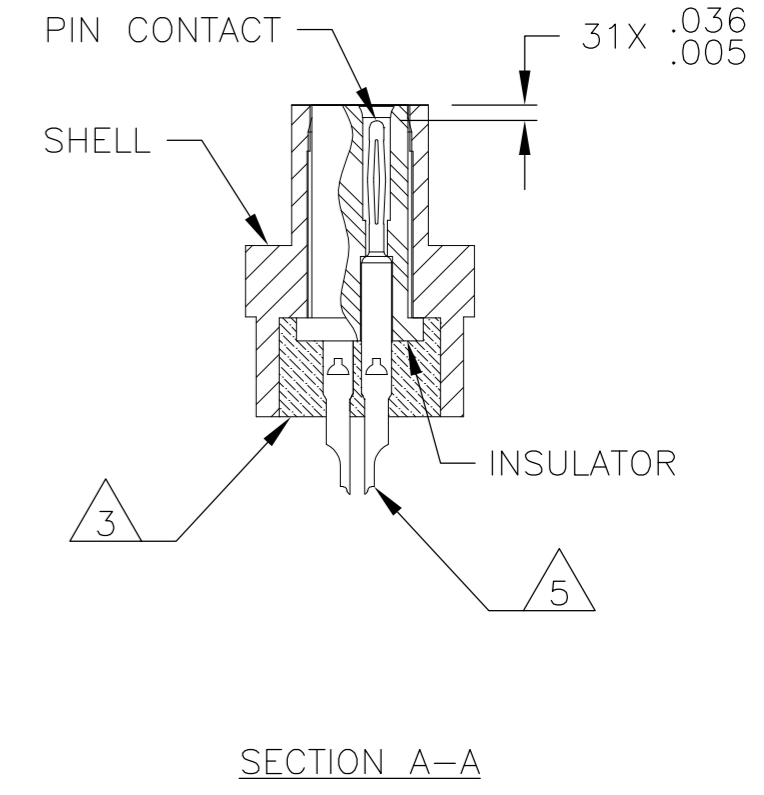
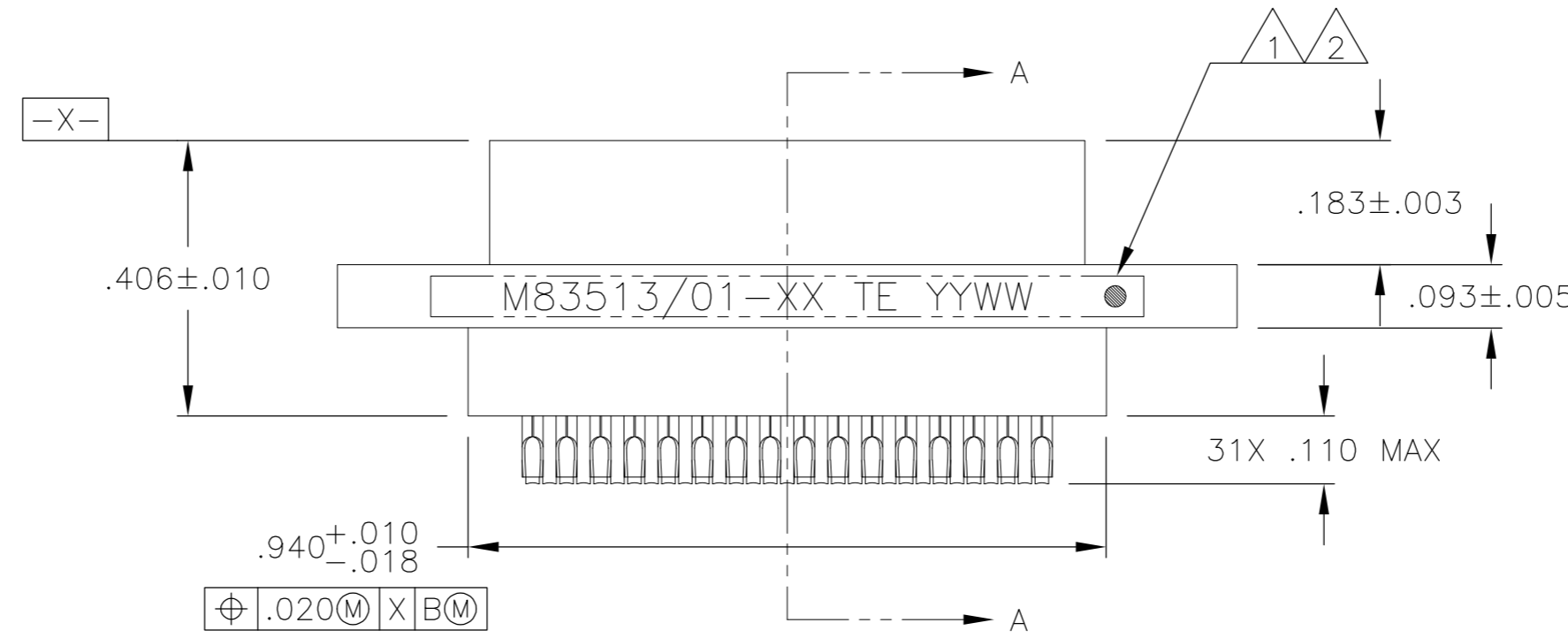
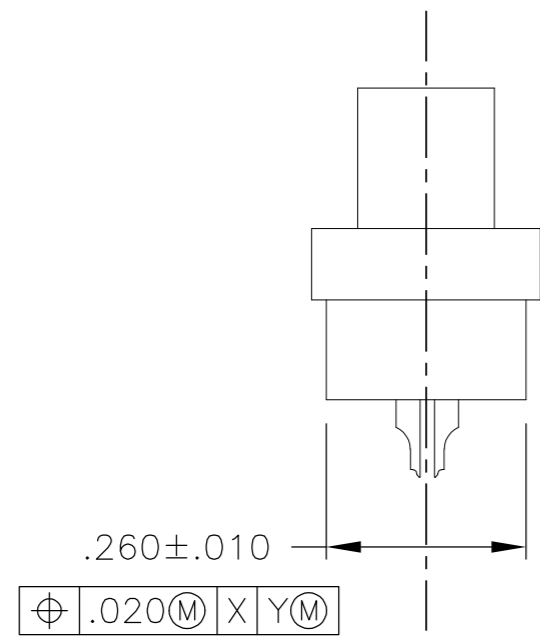
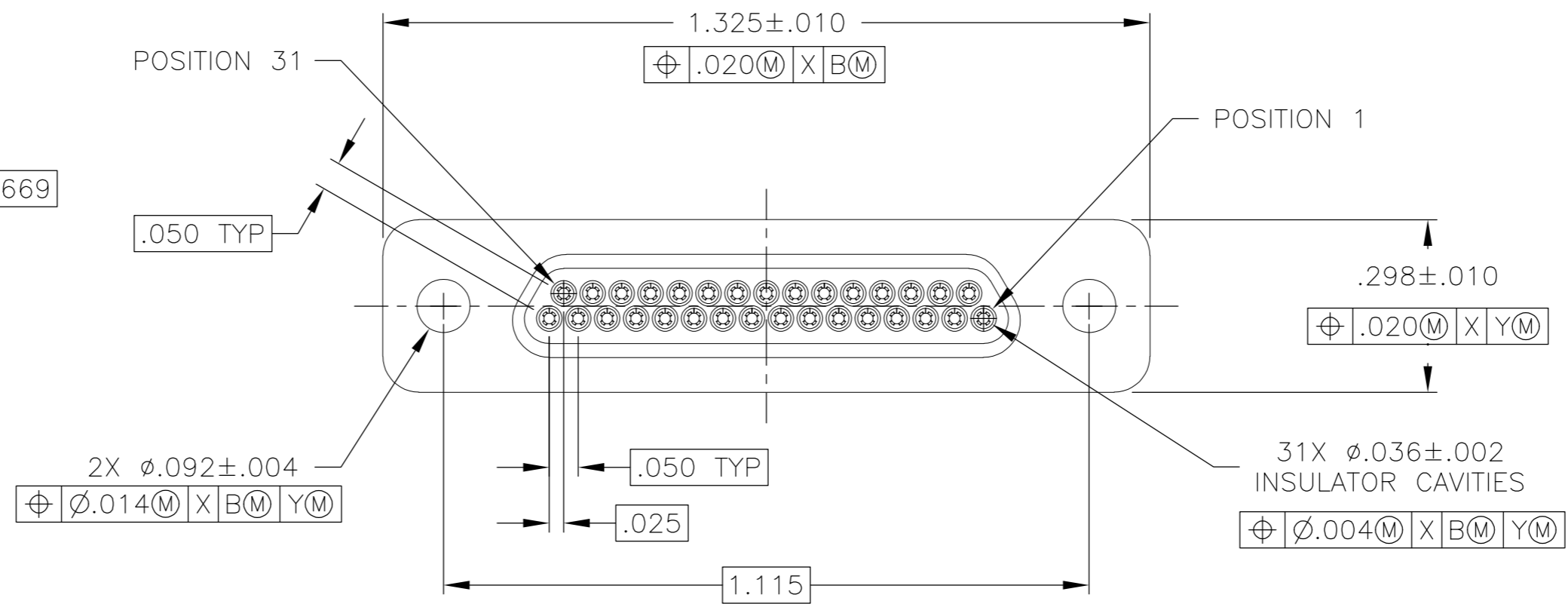
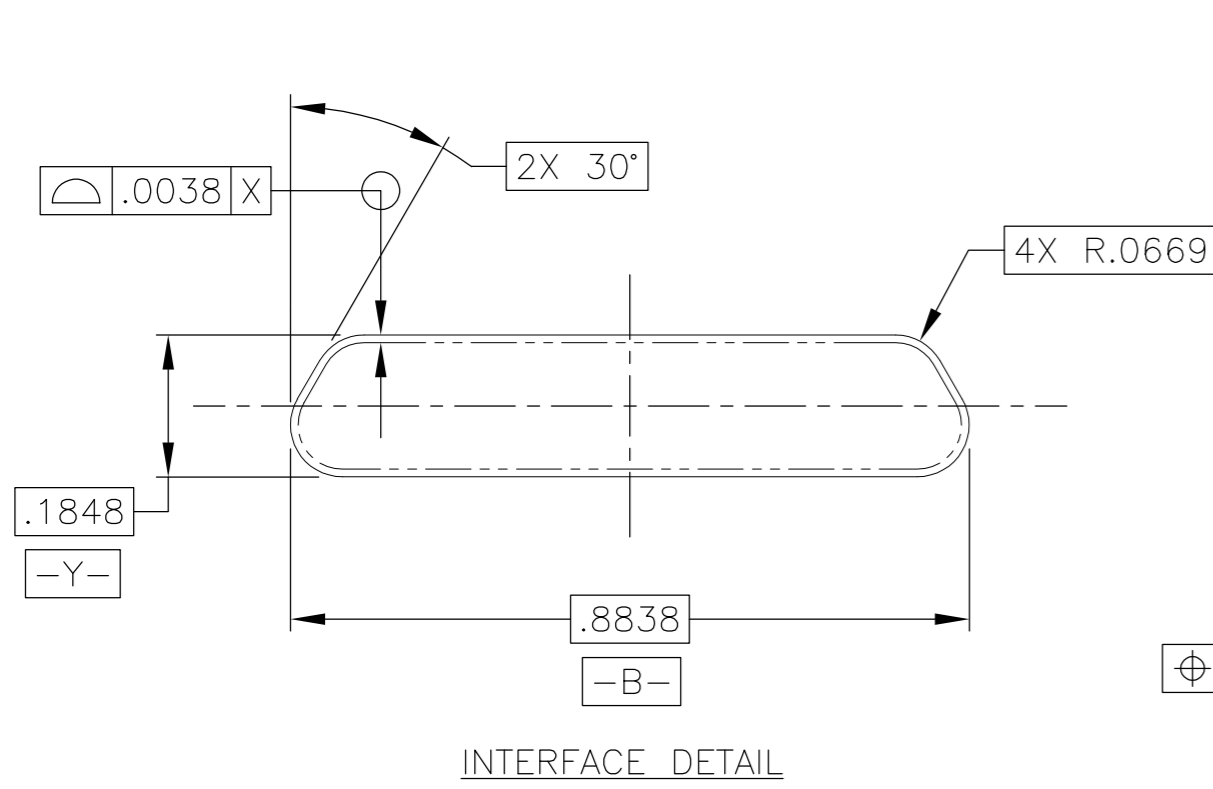

- 1 CONNECTOR SHALL BE MARKED IN ACCORDANCE WITH METHOD I OF MIL-STD-1285. MARKING SHALL CONTAIN THE MILITARY PIN, CAGE CODE (OR TE), AND DATE CODE. EXAMPLE: M83513/01-XX TE YYWW (WHERE XX IS PART OF THE PIN SHOWN IN THE "MIL-DTL-83513" COLUMN OF THE PART NUMBER TABLE, AND YYWW IS THE DATE CODE). TEXT HEIGHT SHALL BE .035 INCH MINIMUM.
- 2 POSITION 1 SHALL BE INDICATED BY AN IDENTIFIABLE MARK, LOCATED APPROXIMATELY AS SHOWN ON THE POSITION 1 SIDE OF THE CONNECTOR FLANGE. THIS MARK SHALL BE INCLUDED AS PART OF THE PART MARKING INFORMATION.
- 3 EPOXY ENCAPSULATION. EPOXY MAY WICK .050 INCH MAX FOR SOLDER CUPS.
- 4 ALL DIMENSIONS AND REQUIREMENTS ARE PER MIL-DTL-83513/1
- 5 CHAMFER ON SOLDER POTS ARE PARALLEL WITH THE SIDE OF CONNECTOR WITHIN 10°

THIS DRAWING IS A CONTROLLED DOCUMENT.		DWN B. ROMANCHUK 03 SEP 08	TE Connectivity	
DIMENSIONS: INCHES	TOLERANCES UNLESS OTHERWISE SPECIFIED:	CHK M. STORRY 03 SEP 08	NAME PLUG ASSEMBLY, MICRO-D PER MIL-DTL-83513/01, MCKS SERIES, 31 POSITION	
MATERIAL SEE NOTES	FINISH -	0 PLC ± -	SIZE A2	CAGE CODE 98278
		1 PLC ± -	DRAWING NO C=1532213	
		2 PLC ± .010	RESTRICTED TO -	
		3 PLC ± .005	SCALE 4:1	SHEET 1 of 2
		4 PLC ± -	REV B	
		ANGLES ± 1°		



## X-ON Electronics

Largest Supplier of Electrical and Electronic Components

*Click to view similar products for [D-Sub Micro-D Connectors](#) category:*

*Click to view products by [TE Connectivity](#) manufacturer:*

Other Similar products are found below :

[65-1920-15](#) [M83513/03-A10N](#) [M83513/03-G12N](#) [M83513/04-G04C](#) [M83513/22-D01NP](#) [664020C06F060](#) [6R2004A30F015](#)  
[6R4006A28A120](#) [704002A03F200](#) [705001A13F120](#) [71-147714-19P](#) [7-1532020-5](#) [748567-1-P](#) [MDB1-9SH001](#) [MDM-100PH003L](#) [MDM-](#)  
[15PBS-L58](#) [MDM-15PCBRM7T](#) [MDM-15PH001M7-A174](#) [MDM-15PH003B-A174](#) [MDM-15SH003A](#) [MDM-15SH004B](#) [MDM-](#)  
[15SH006A-A174](#) [MDM-15SH048B](#) [MDM-21PH003P](#) [MDM-25PH003B-A174](#) [MDM-25SH003F](#) [MDM-25SH003K](#) [MDM-31PH003L](#)  
[MDM-37PH006L-A174](#) [MDM-37SH003K](#) [MDM51PH016FA174](#) [MDM-51PSF](#) [MDM-9PH003M7](#) [MDM-9SH001P](#) [MDM-9SH006B](#) [790-](#)  
[027SH-10P4MEP](#) [790-041PJ-25P2MPA](#) [790-043PJ-7P7MPB](#) [791-004SH-66MSA](#) [7R3A00A19A1201](#) [7R5006A19A120](#) [803000C02M020](#)  
[803001B02M040](#) [803001D01M040](#) [8030N1A09M020](#) [804001B03M100](#) [804006B03M100](#) [804006C02M030](#) [MLDM2L-21SCBRP-.110](#)  
[85043GULSR](#)