

- 1. LOCKING DEVICE BETWEEN CAVITY-NO.
Verriegelung zwischen Kammer-Nr.
- 2. KEYING RIB ON FIRST AND LAST CAVITY
Kodierrippen bei erster und letzter Kammer SEE 13
- 2a. TYPICAL KEYING RIB
Typische Kodierrippen SEE 13
- 3. POLARIZATION RIB (ALL)
Polarisierungsrippen (alle) SEE 19
- 4. AMP LOGO, MATERIAL DISCRPTION (PA6)
AMP LOGO, Materialbezeichnung (PA6)
- 5. CONNECTOR WITH DOUBLE WIRE FOR WIRE RANGE: (ONLY Δ)
0.5+0.5, 0.5+0.75. (SEE APPL SPEC.ND.114-18288)
Connector mit Doppelanschlag fuer Litze: (nur Δ)
0.5+0.5, 0.5+0.75. siehe Appl.Spec.Nr.114-18288
- 6. CONNECTOR WITH SINGLE WIRE FOR WIRE RANGE: 0.35-1.5mm²
(SEE APPL SPEC.ND.114-18382), 0.35-1.0mm² SEE Δ, 1.0-1.5mm² SEE Δ
Connector mit Einzelanschlag fuer Litze: 0.35-1.5mm²
(siehe Appl.Spec.Nr.114-18382), 0.35-1.0mm² siehe Δ, 1.0-1.5mm² siehe Δ
- 7. STRANDED WIRE BENT TO 90° (ONLY FOR SINGLE WIRE POSSIBLE)
Litze 90° gebogen (nur bei Einzelanschlag moeglich)
- 8. AMP NO. (HOUSING PN), PRE- AND SUFFIX ONLY
AMP Nr. (Gehauese PN), nur Vor- und Nachstrichzahl
- 9. CAVITY LOADED WITH CONTACT FOR DGB 0.35-1.0mm² (CuZn30 POSTFINNED)
Kammer bestueckt mit Kontakt fuer DGB 0.35-1.0mm² (CuZn30 posttinnend)
- 10. PACKAGING SEE SPEC. 107-18008
Verpackung siehe Verpackungsanweisung 107-18008
- 11. CONTACT POSITION IN CAVITY
Kontaktlage in Kammer
- 12. ASS'Y PN, ONLY PRE- AND SUFFIX. ATTENTION: IDENTIFICATION OF THE COMPLETE ASS'Y PN ONLY POSSIBLE WITH PRE-, SUFFIX, MATERIAL Δ AND CHART. THE COMPLETE ASS'Y PN IS VISIBLE ON PACKAGING
Ass'y PN nur Vor- und Nachstrichzahl. Achtung: Identifizierung der kompletten Ass'y PN nur mit Vor-, Nachstrichzahl, Material Δ und Tabelle moeglich. Die komplette Ass'y PN ist auf der Verpackung ersichtlch
- 13. NOTE 2, 2a, 3, IN PROCESS CUT OFF INDIVIDUAL
Im Prozess betrieb abschneidbar
- 14. SLOT ACCEPT TAB 6.3x0.8, 4.8x0.8 AT DIN e.g. 46244
Kontaktbereich geeignet fuer Tab 6.3x0.8, 4.8x0.8 nach DIN z.B. 46244
- 15. WIRE SUPPORT
Drahtunterstuetzung

- 16. REEL CLIPS CAN BE CUT OFF
Reelverfassung kann abgeschnitten werden
- 17. MATING STOP
Tiefenanschlag
- 18. HSG. CAVITY NO.
Gehauese Kammer Nr.
- 19. CAVITY LOADED WITH CONTACT FOR DGB 1.0-1.5mm² (CuNiSi POSTSILVERED)
Kammer bestueckt mit Kontakt fuer DGB 1.0-1.5mm² (CuNiSi postsilvered)
- 20. ATTENTION: KEYING RIB "4d" FROM THIS SPECIAL VARIETY HAS ANOTHER HIGHT DIMENSION. SEE VIEW "V"
Achtung: Kodierrippe "4d" dieser Sondervariante hat eine andere Hoehenabmessung. Siehe Ansicht "V"
- 21. NOT DEFINED YET
Noch nicht festgelegt
- 22. VIEW WITH CLOSED COVER
Ansicht mit geschlossenem Deckel gezeichnet
- 23. EXPANSION OF DIMENSION "Y" AFTER TERMINATION BY USING 4 POS. CONNECTORS WITH 1.5mm² STRANDED WIRE AND 8 POS. CONNECTORS WITH 0.75mm² STRANDED WIRE SEE APPL. SPEC.
Aufweitung Mass "Y" nach dem Anschlag bei 4pol. Connectoren mit 1.5mm² Litze und bei 8pol. Connectoren mit 0.75mm² Litze siehe Appl. Spec.
- 24. FOR DOUBLE WIRE SEE APPL. SPEC.
Bei Doppelanschlag siehe Appl. Spec.
- 25. AREA FOR COLOUR MARKING POSSIBLE
Platz fuer farbige Markierung moeglich
- 26. KEYING. VIEW AT DIRECTION "Z"
Kodierschema: Ansicht in Richtung "Z"
- 27. VARIETY ON REQUEST
Variante auf Anfrage
- 28. FOR INFORMATION ONLY
Nur zur Info
- 29. MATERIAL PA6 (GW T. 750°C WITHOUT FLAME)
Material PA6 (Guehndrahtueruefung 750°C ohne Flamme)
- 30. ELASTIC DEFORMATION OUTWARDS IS ACCEPTABLE IN THE MARKED AREA.
WDRKABILITY AND MODULARITY IS GRANTED
Elastische Verformung nach auen ist im markierten Bereich zulässig.
Verarbeitbarkeit bzw. Anreihbarkeit ist nicht gefaehrdet
- 31. -
- 32. OBSOLETE
- 33. CAVITY LOADED WITH CONTACT FOR DGB 0.35-1.0mm² (CuZn37 POSTFINNED)
Kammer bestueckt mit Kontakt fuer DGB 0.35-1.0mm² (CuZn37 posttinnend)

LOC	DIST	REV	DATE	OWN	APVD
A1	-	3	22FEB2007	OFL	SZB
PROJECT NO.: EGPLC00537		C3	NOTE 30 AND SHEET 2 ADDED		
		C4	-		
		C5	ECR-16-014315	11OCT2016	FV RR
		C6	ECR-17-004546	06APR2017	IZ RR

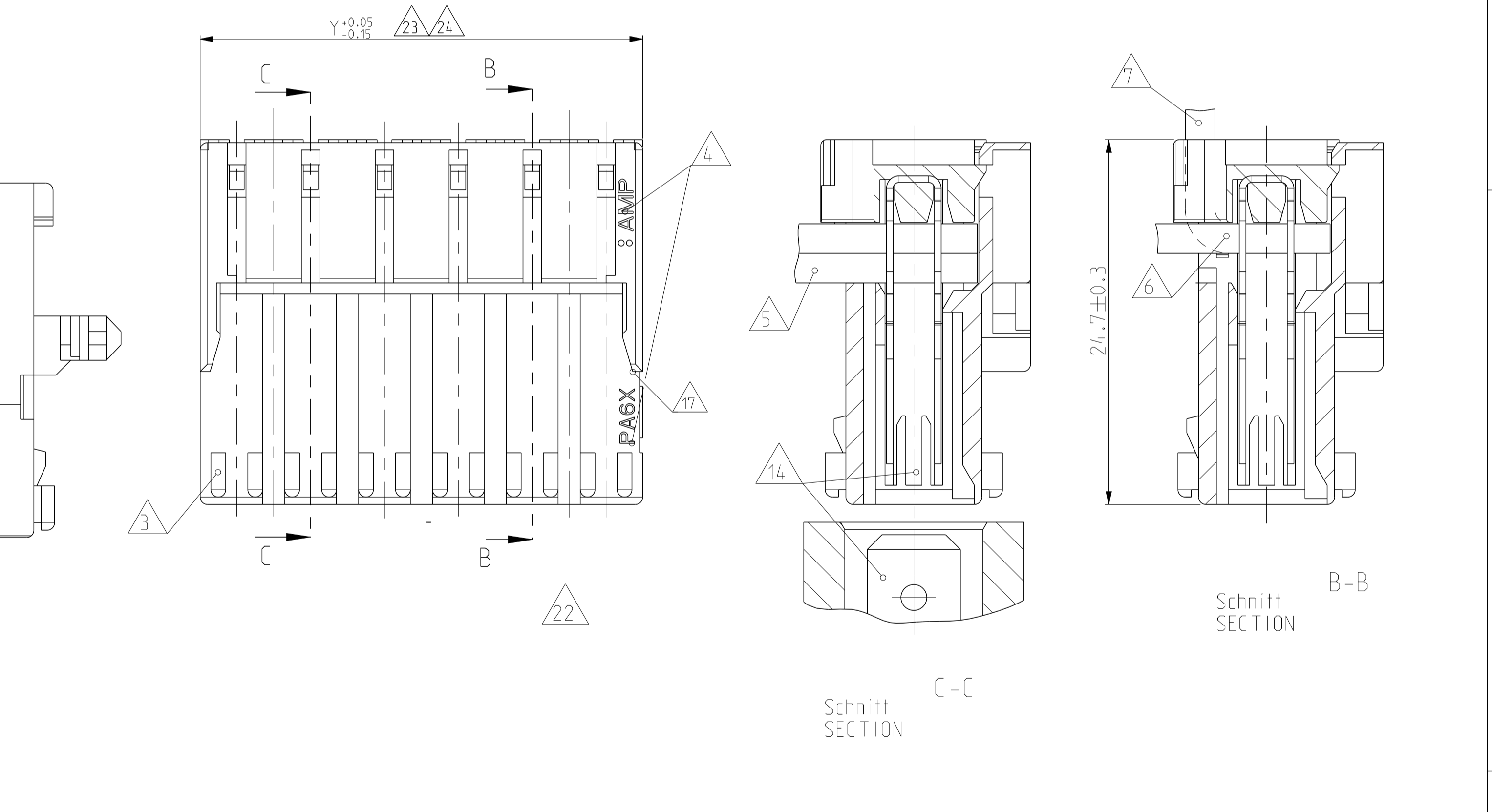
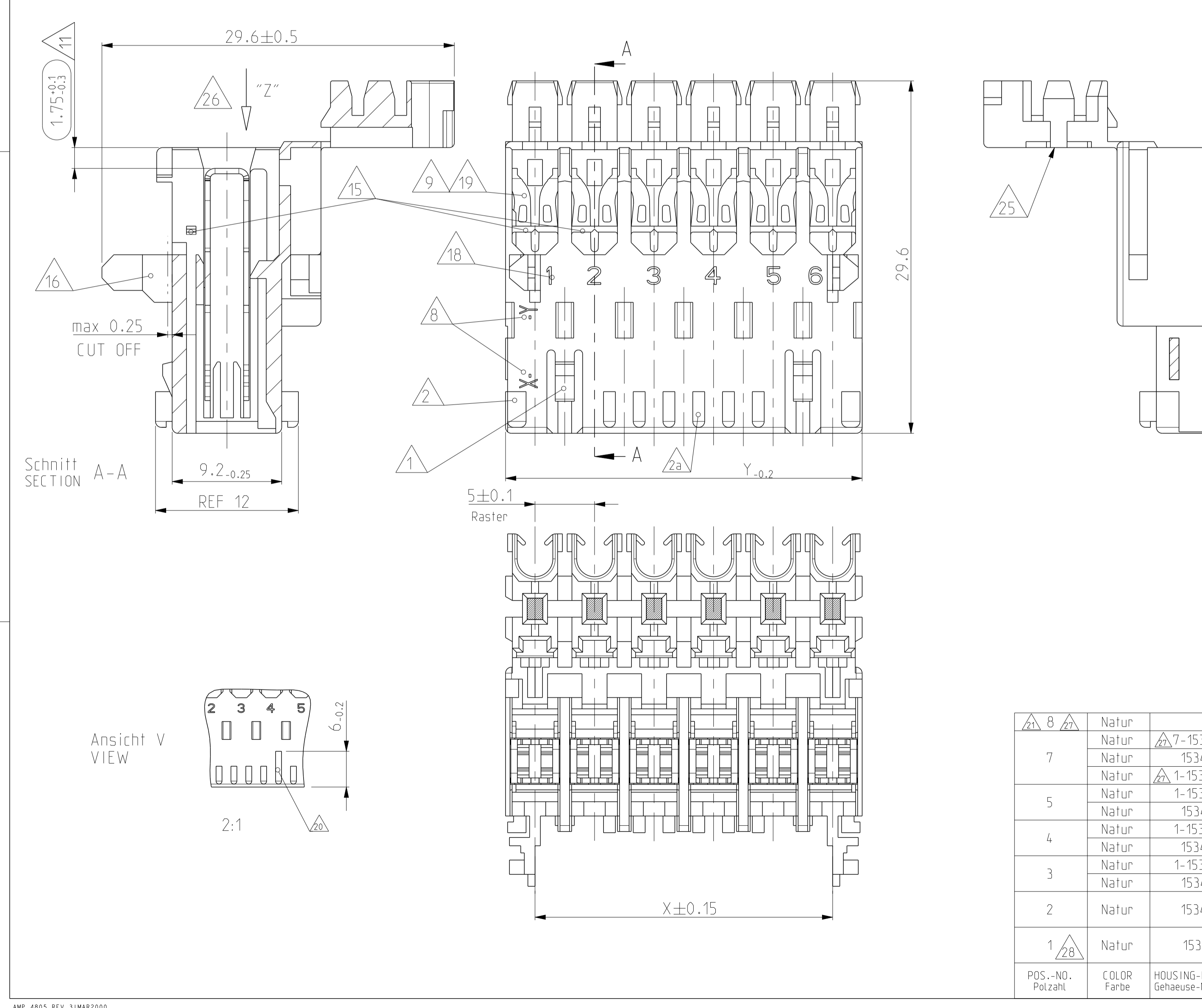

POS.-NO. Polzahl	COLOR Farbe	HOUSING-NO. Gehauese-Nr.	ASSY NO. Assy Nr.	ASSY NO. Assy Nr.	ASSY NO. Assy Nr.	DIM "X" Mass "X"	DIM "Y" Mass "Y"
8	Natur	-	-	-	-	35	39.95
7	Natur	7-1534076-7	7-1534077-7	7-2309920-7	-	30	34.95
	Natur	1534076-7	1534077-7	2309920-7	-	30	34.95
5	Natur	1-1534076-5	1-1534077-5	1-2309920-5	-	20	24.95
	Natur	1534076-5	1534077-5	2309920-5	-	20	24.95
4	Natur	1-1534076-4	1-1534077-4	1-2309920-4	1-1534078-4	15	19.95
	Natur	1534076-4	1534077-4	2309920-4	1534078-4	15	19.95
3	Natur	1-1534076-3	1-1534077-3	1-2309920-3	1-1534078-3	10	14.95
	Natur	1534076-3	1534077-3	2309920-3	1534078-3	10	14.95
2	Natur	1534076-2	1534077-2	2309920-2	1534078-2	5	9.95
1	Natur	1534071-1	1534072-1	-	1534073-1	-	4.95

THIS DRAWING IS UNCLASSIFIED
 RELEASED FOR PUBLICATION
 DATE 12/01/2010
 BY TYCO ELECTRONICS CORPORATION ALL RIGHTS RESERVED.
 COPYRIGHT 19 BY TYCO ELECTRONICS CORPORATION. ALLE RECHTE VORBEHALTEN.

OWNER: AMP Deutschland GmbH
 D - 63225 Langen
 DRAWING NO.: 1534077
 SCALE: 4:1
 SHEET: 1 OF 2
 REV: C6

AMP
 AMP Deutschland GmbH
 D - 63225 Langen

NAME: 2-8pos. AMP multifitting Mark II ASSEMBLY PITCH 5mm TAB VERSION INTERIOR LOCKING

SIZE: A1
 CAGE CODE: 00779
 DRAWING NO.: 1534077

RESTRICTED TO: NUR FÜR: -

CUSTOMER DRAWING

LOC	DIST	REVISIONS				
		P. LTH	DESCRIPTION	DATE	DWN	APVD
A1	-	-	SEE SHEET 1	-	-	-

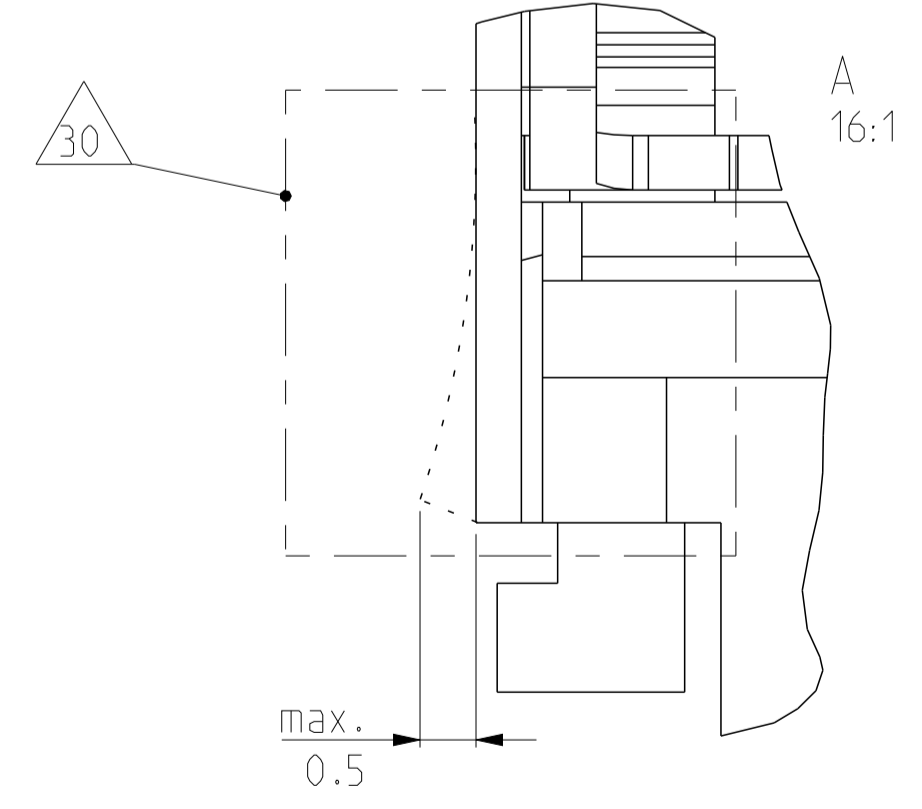
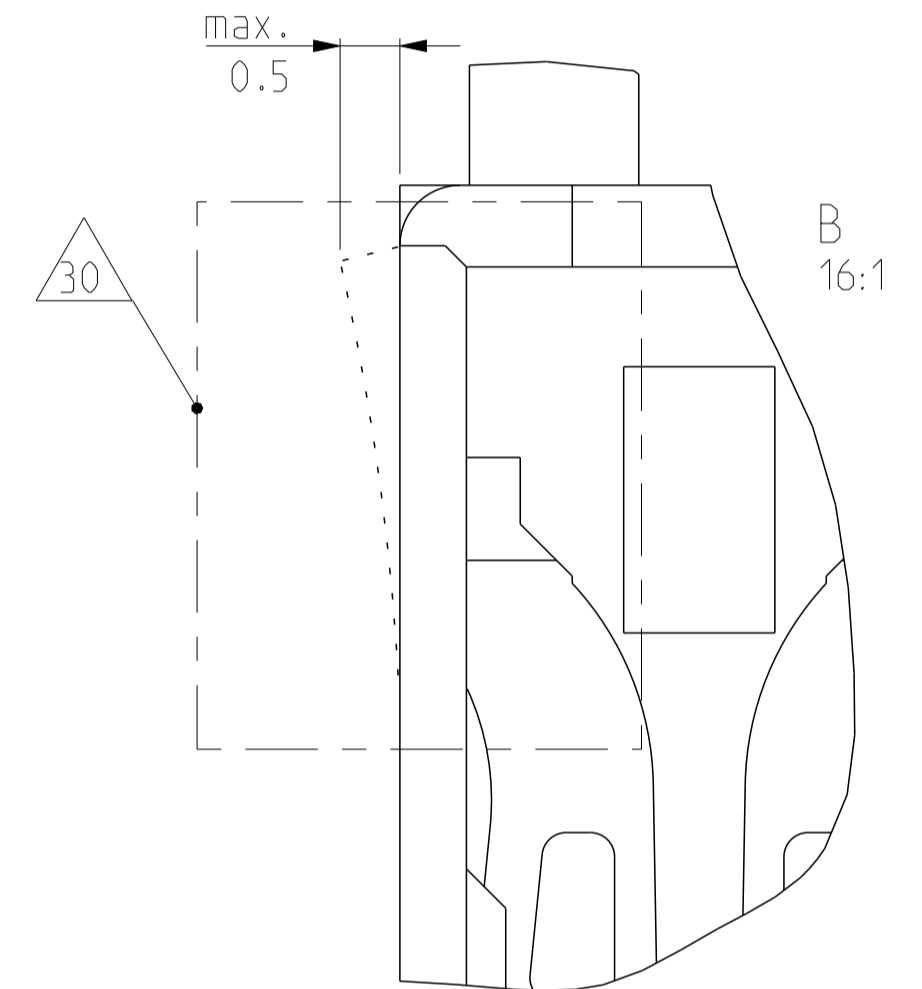
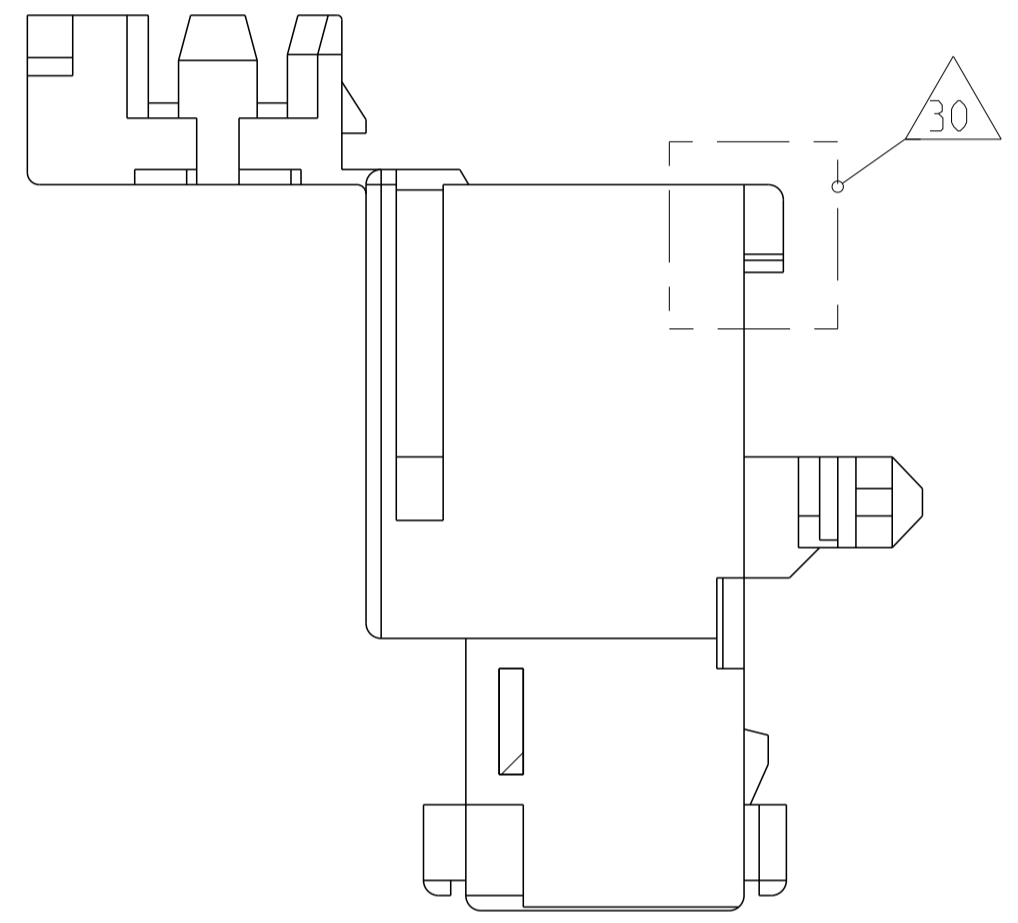
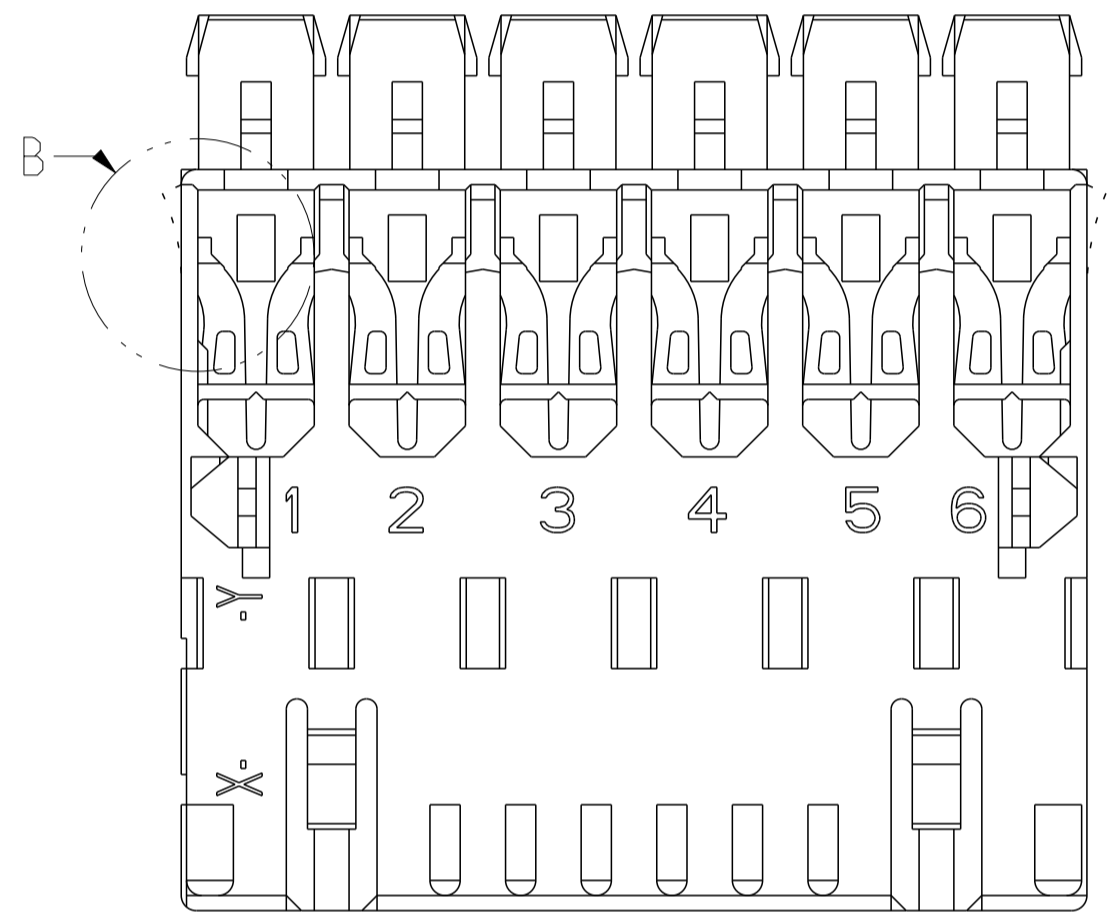

NOTES & TABLES, SEE SHEET 1
 Notizen & Tabellen, siehe Blatt 1

<small>THIS DRAWING IS UNPUBLISHED. RELEASED FOR PUBLICATION 19. THIS IS THE PROPERTY OF TYCO ELECTRONICS CORPORATION. IT IS THE POLICY OF TYCO ELECTRONICS CORPORATION TO CONTROL AND RESTRICT THE DISTRIBUTION OF THIS DRAWING TO THE LATEST REVISION.</small>		DWN: M. Otenloch 03DEC01 CHK: G. Bartosch 03DEC01 APVD: Th. Klenner 03DEC01	AMP AMP Deutschland GmbH D - 63225 Langen
DIMENSIONS: mm TOLERANCES UNLESS OTHERWISE SPECIFIED: 0 PLC ±0.2 1 PLC ± 2 PLC ± 3 PLC ± 4 PLC ± ANGLES ±2° MATERIAL: PA 6 FINISH: -		NAME: 2-8pos. AMP multifitting Mark II ASSEMBLY PITCH 5mm TAB VERSION INTERIOR LOCKING SIZE: 108-18652 APPLICATION SPEC: 116-18382 WEIGHT: - CUSTOMER DRAWING	RESTRICTED TO: - SCALE: 4:1 SHEET: 2 OF 2 REV: C6

X-ON Electronics

Largest Supplier of Electrical and Electronic Components

Click to view similar products for [Headers & Wire Housings](#) category:

Click to view products by [TE Connectivity](#) manufacturer:

Other Similar products are found below :

[892-18-020-10-001101](#) [58102-G61-06LF](#) [582553-1](#) [0009485154](#) [009176003701906](#) [0050291907](#) [LY20-4P-DT1-P1E-BR](#) [02.125.8002.8](#)
[609-3404](#) [61062-3](#) [61082-181009](#) [622-3653LF](#) [63453-116](#) [636-1030](#) [636-1427](#) [636-3427](#) [636-4007](#) [641938-9](#) [641991-4](#) [644827-2](#) [65817-](#)
[010LF](#) [65817-015LF](#) [65863-015LF](#) [66207-023LF](#) [67095-007LF](#) [67601157](#) [68645-018](#) [68648-049](#) [70.362.1628.0](#) [70-4210](#) [70-4226B](#) [70-](#)
[4853B](#) [707-5020](#) [707-5028](#) [71.350.2428.0](#) [71918-208LF](#) [71961-016LF](#) [733-134](#) [733-162](#) [754199-000](#) [760-3052](#) [787-8014-00](#) [79531-3000](#)
[FCN-360C032-B](#) [FCN-367T-T012/H](#) [FCN-723D010/2](#) [80.063.4001.1](#) [800-90-001-10-001000](#) [800-90-010-10-002000](#) [801-43-002-10-013000](#)