

THIS DRAWING IS UNPUBLISHED. RELEASED FOR PUBLICATION 20
 © COPYRIGHT 20 BY TYCO ELECTRONICS CORPORATION. ALL RIGHTS RESERVED.

LOC		DIST		REVISIONS			
P	LTR	DESCRIPTION	DATE	DWN	APVD		
	A2	REVISED PER ECO-09-004973	27FEB2009	HMR	CR		

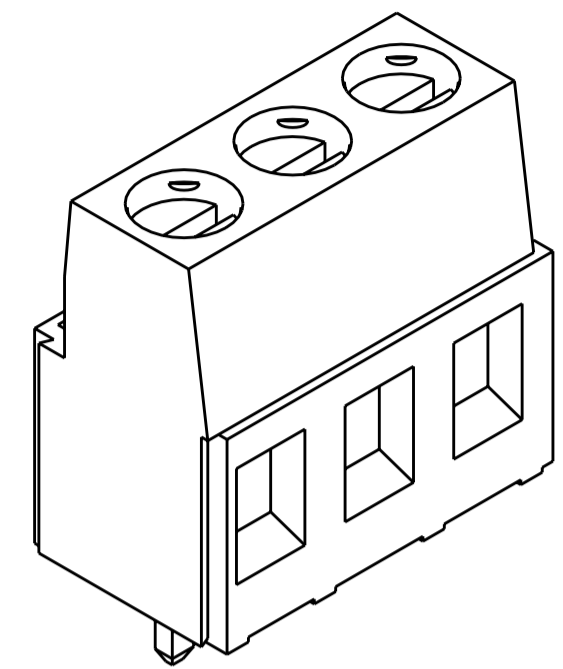
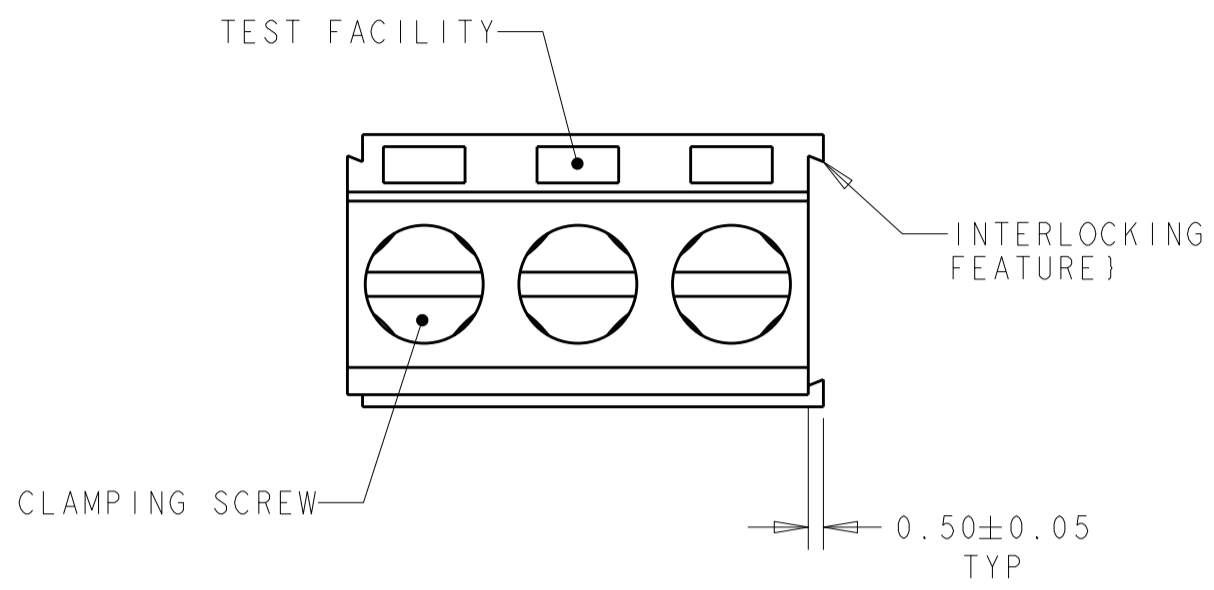

1546218-3 AS SHOWN

- 1. MATERIALS AND FINISH:
 HOUSING: PA 6-6, UL 94-V0, COLOR: GRAY.
 CLAMP: BRASS, NICKEL PLATED.
 TERMINAL: BRASS, TIN PLATED.
 CLAMPING SCREW: M3, BRASS, NICKEL PLATED.
- 2. SUITABLE FOR 1,6-2,4mm. PCB THICKNESS.
- 3. END-TO-END STACKABLE W/INTERLOCK WITHOUT LOSS OF CENTERLINE SPACING.
- 4. WIRE SIZE RANGE: 12-30 AWG
- 5. RECOGNIZED UNDER THE COMPONENT PROGRAM OF UNDERWRITERS LABORATORIES INC. FILE No E60677.
- 6. IMQ CERTIFICATE WITH SURVEILLANCE IN CONFORMITY WITH IEC 998-1/998-2-1.

7. NOT CUMULATIVE TOLERANCE.

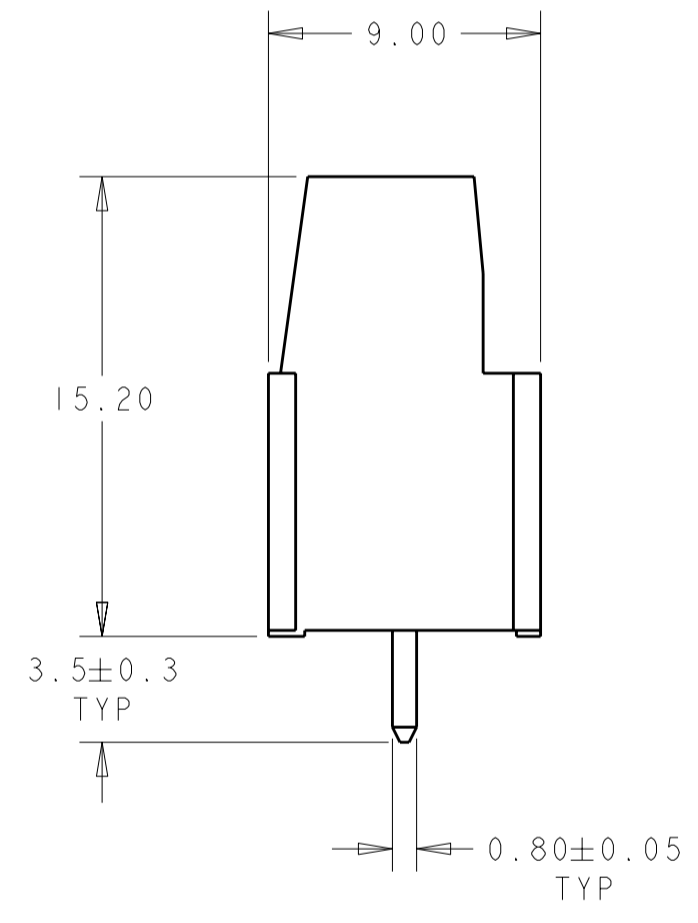
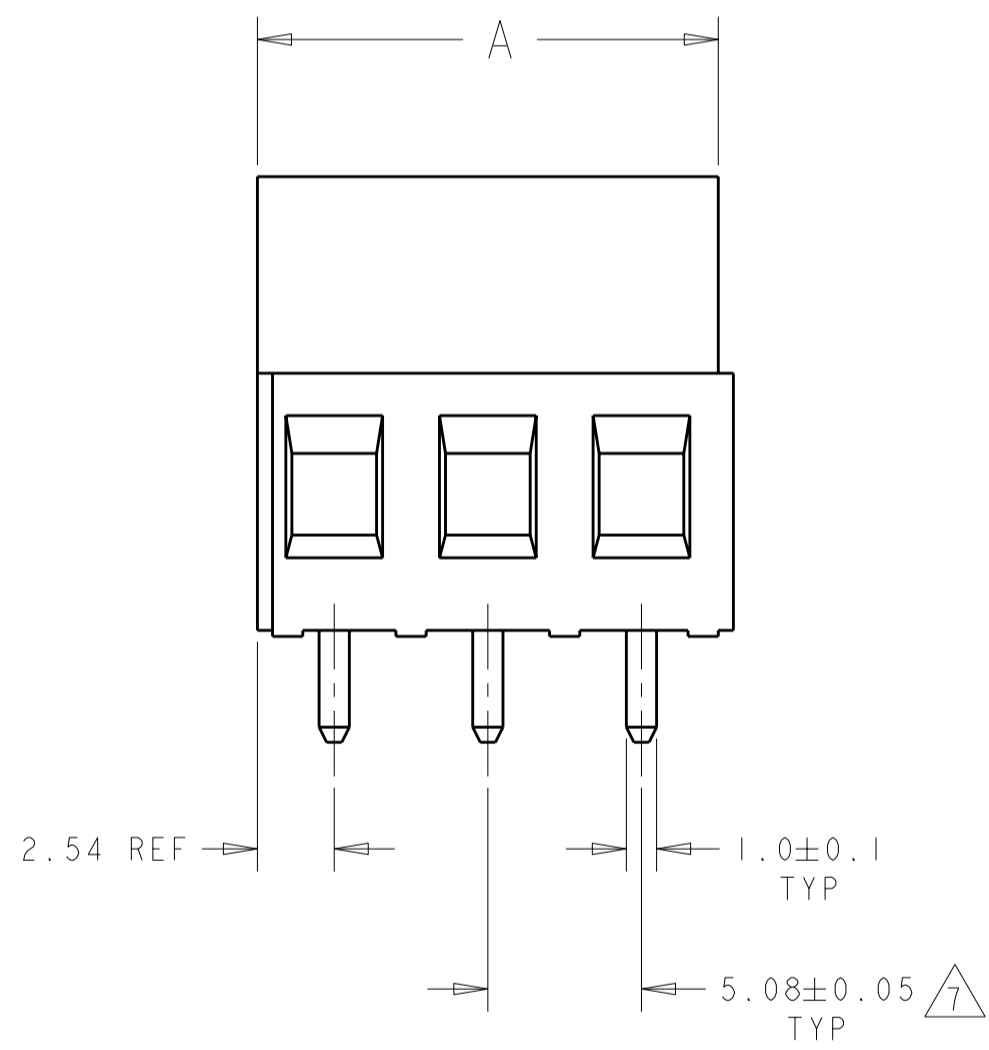

	127.00	25	2-1546218-8
	121.92	24	2-1546218-7
	116.84	23	2-1546218-6
	111.76	22	2-1546218-5
	106.68	21	2-1546218-4
	101.60	20	2-1546218-3
	96.52	19	2-1546218-2
	91.44	18	2-1546218-1
	86.36	17	2-1546218-0
	81.28	16	1-1546218-9
	76.20	15	1-1546218-8
	71.12	14	1-1546218-7
	66.04	13	1-1546218-6
OBSOLETE	40.64	8	1-1546218-5
OBSOLETE	35.56	7	1-1546218-4
OBSOLETE	35.56	7	1-1546218-3
	60.96	12	1-1546218-2
	55.88	11	1-1546218-1
	50.80	10	1-1546218-0
	45.72	9	1546218-9
	40.64	8	1546218-8
	35.56	7	1546218-7
	30.48	6	1546218-6
	25.40	5	1546218-5
	20.32	4	1546218-4
	15.24	3	1546218-3
	10.16	2	1546218-2
A	NO OF POSN		PART NUMBER

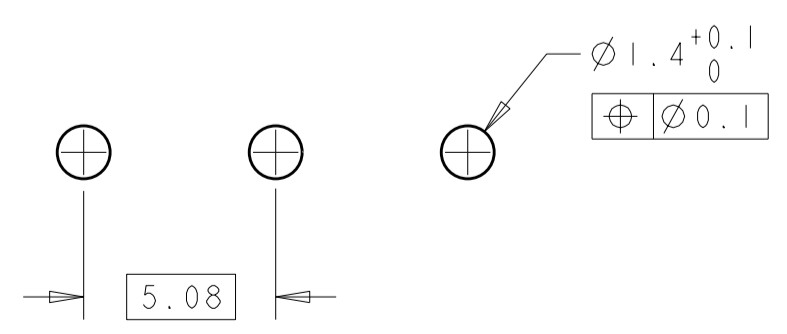

RECOMMENDED PC BOARD LAYOUT
SCALE 5:1

THIS DRAWING IS A CONTROLLED DOCUMENT FOR TYCO ELECTRONICS CORPORATION. IT IS SUBJECT TO CHANGE AND THE CONTROLLING ENGINEERING ORGANIZATION SHOULD BE CONTACTED FOR THE LATEST REVISION.		DWN S. WELDON 02OCT2003	Tyco Electronics Harrisburg, PA 17105-3608	
DIMENSIONS: mm		CHK C. RICHARD 02OCT2003	NAME TERMINAL BLOCK, PCB MOUNT, STACKABLE, W/ INTERLOCK, SIDE WIRE ENTRY, 5.08mm PITCH	
TOLERANCES UNLESS OTHERWISE SPECIFIED: 0 PLC ±0 1 PLC ±.3 2 PLC ±.25 3 PLC ±0 4 PLC ±0 ANGLES ±2° FINISH		APVD C. RICHARD 02OCT2003	SIZE A200779	
MATERIAL		PRODUCT SPEC -	DRAWING NO 1546218	
		APPLICATION SPEC -	RESTRICTED TO -	
		WEIGHT -	SCALE 4:1	
		CUSTOMER DRAWING	SHEET 1 OF 1 REV A2	

X-ON Electronics

Largest Supplier of Electrical and Electronic Components

Click to view similar products for [Fixed Terminal Blocks](#) category:

Click to view products by [TE Connectivity](#) manufacturer:

Other Similar products are found below :

[MBE-1512](#) [MBE-154](#) [MBE-156](#) [MBES-153](#) [MBES-156](#) [MH-2512](#) [MHE-132](#) [MHE-163](#) [MI-254 \(35\)](#) [MI-272](#) [880507](#) [MPT-275](#)
[15602-04-08-21](#) [ELM023100](#) [BA311TU](#) [BA411SU](#) [MV-152](#) [MV-252-D](#) [MV-253/NCNOC](#) [MV-254-D](#) [MV-255](#) [MV-462](#) [MV-493](#) [MVE-](#)
[252](#) [MVE-253](#) [MVE-273](#) [MVEB-153](#) [1700096](#) [1705142](#) [1712417](#) [1713020](#) [1713088](#) [1745195](#) [1760594](#) [1776118-2](#) [1790852](#) [1-796689-8](#)
[1-796692-6](#) [1800001](#) [1800114](#) [1995279](#) [20020314-C121B01LF](#) [CB2-12](#) [KP03215000J0G](#) [KP04215000J0G](#) [S451](#) [282802-2](#) [29.007](#) [29.116](#)
[30.103](#)