

REVISIONS				
REV	DATE	DESCRIPTION	DATE	APPD
633	REVISED PER ECO-19-005385		11APR2019	JMS HC
634	REVISED PER ECO-19-019125		17DEC2019	CN HC
635	REVISED PER ECO-20-012737		14SEP2020	AP GR
636	REVISED PER ECO-20-016542		28NOV2020	CN HC

LIST OF PARTS

QTY. REQUIRED		ITEM	DESCRIPTION	COLOR	SUPPLIER PART NUMBER	MATERIAL SPECIFICATION	RECYCLING CODE	WEIGHT (GRAM)	
INDEX C	INDEX B								INDEX A
-	-	1	HOUSING, KEYING OPTION 'A'	BLACK	0-1587054-1	30% GF PBT	>PBT-GF30<	49.3g	
-	1	-	HOUSING, KEYING OPTION 'B'	GRAY	0-1587054-2	30% GF PBT	>PBT-GF30<	49.3g	
1	-	-	HOUSING, KEYING OPTION 'C'	NATURAL	0-1587054-3	30% GF PBT	>PBT-GF30<	49.3g	
1	1	1	2	TPA	RED	0-1587055-1	15% GF PBT	>PBT-GF15<	3.1g
1	1	1	3	ALIGNMENT PLATE	NATURAL	0-1587056-1	15% GF PBT	>PBT-GF15<	2.2g
1	1	1	4	END SEAL COVER	BLACK	0-1587057-1	15% GF PBT	>PBT-GF15<	6.3g
1	1	1	5	END SEAL COVER	BLACK	0-1587057-3	15% GF PBT	>PBT-GF15<	6.1g
1	1	1	6	END SEAL GROMMET	LT GREEN	0-1587058-1	SILICON	>IMO<	2.7g

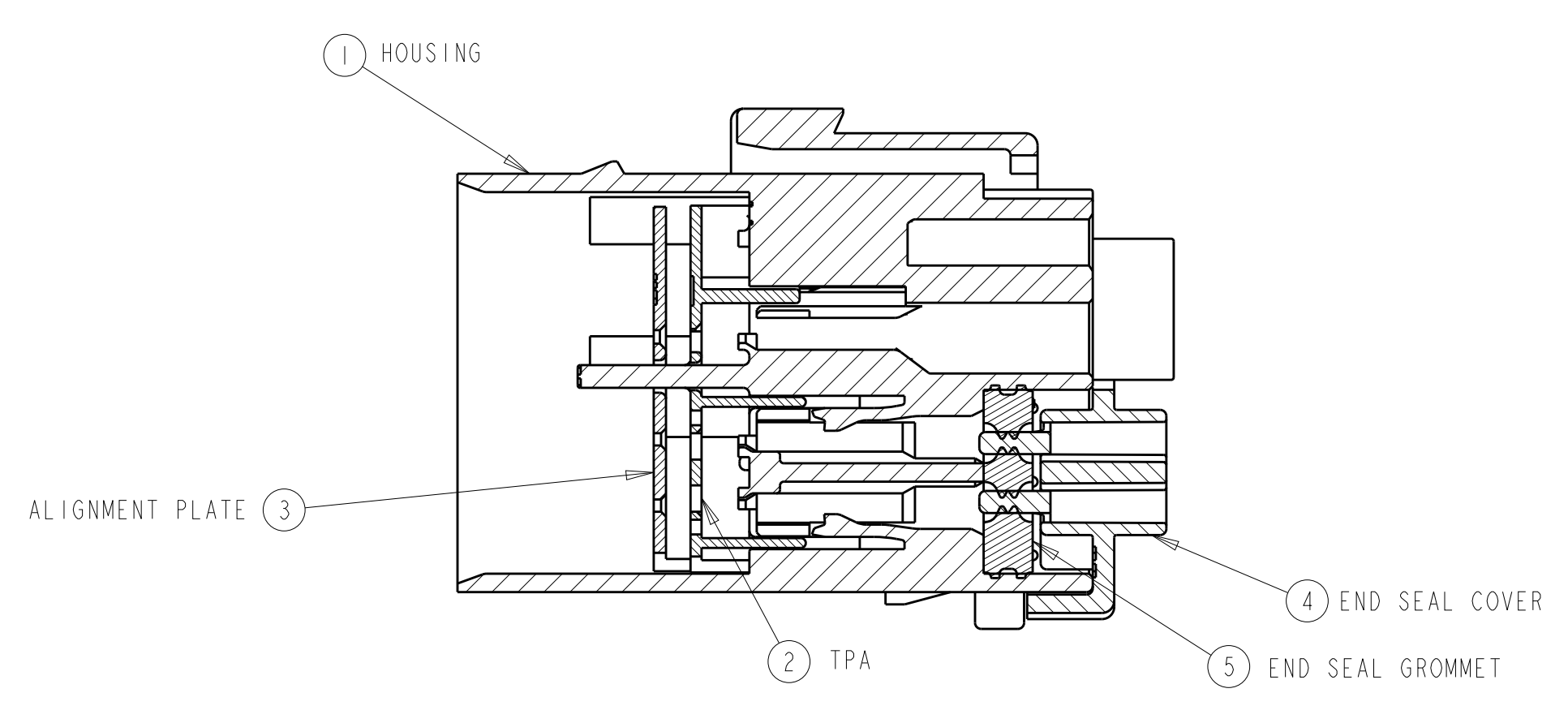
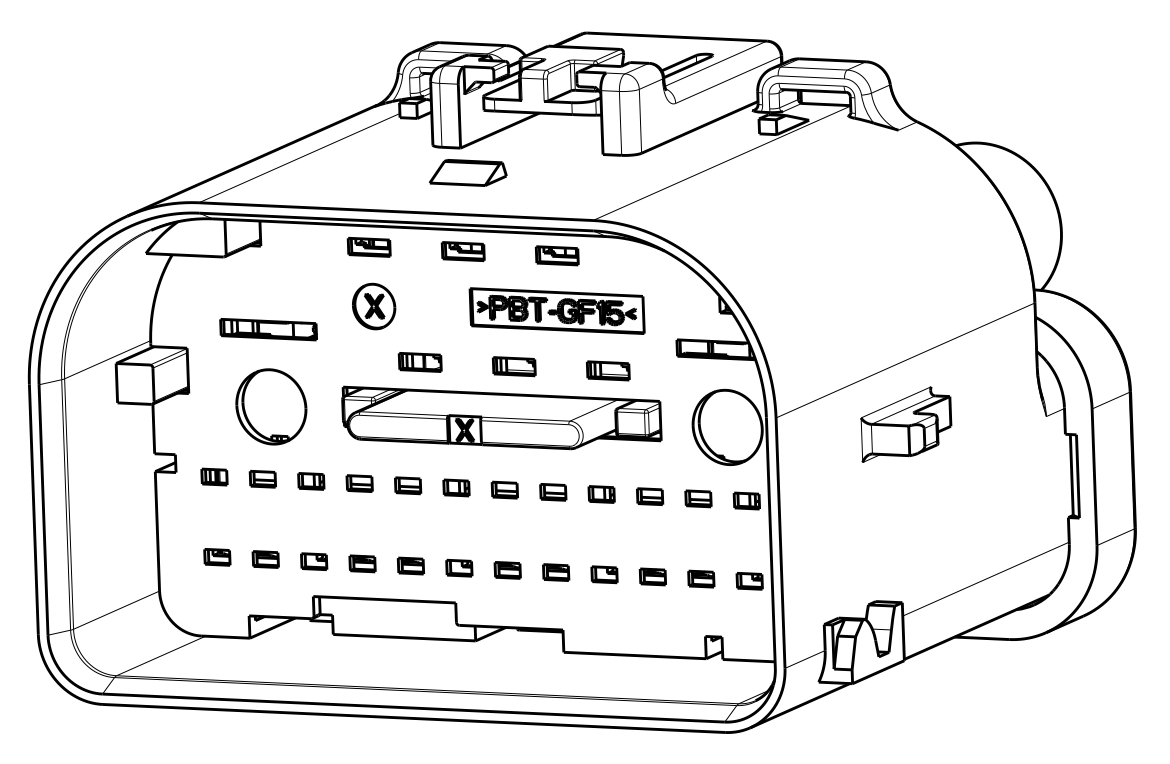
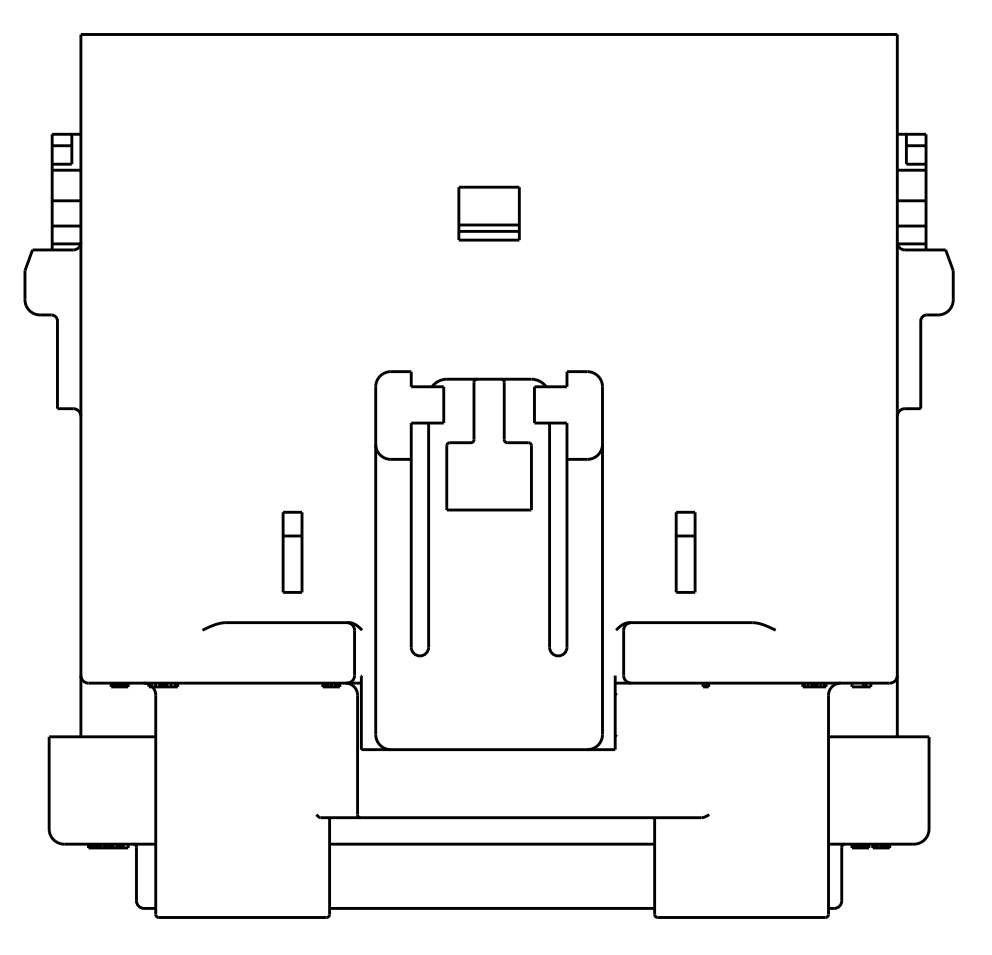

SECTION A-A
 TPA AND ALIGNMENT PLATE
 IN PRE-SEATED POSITION

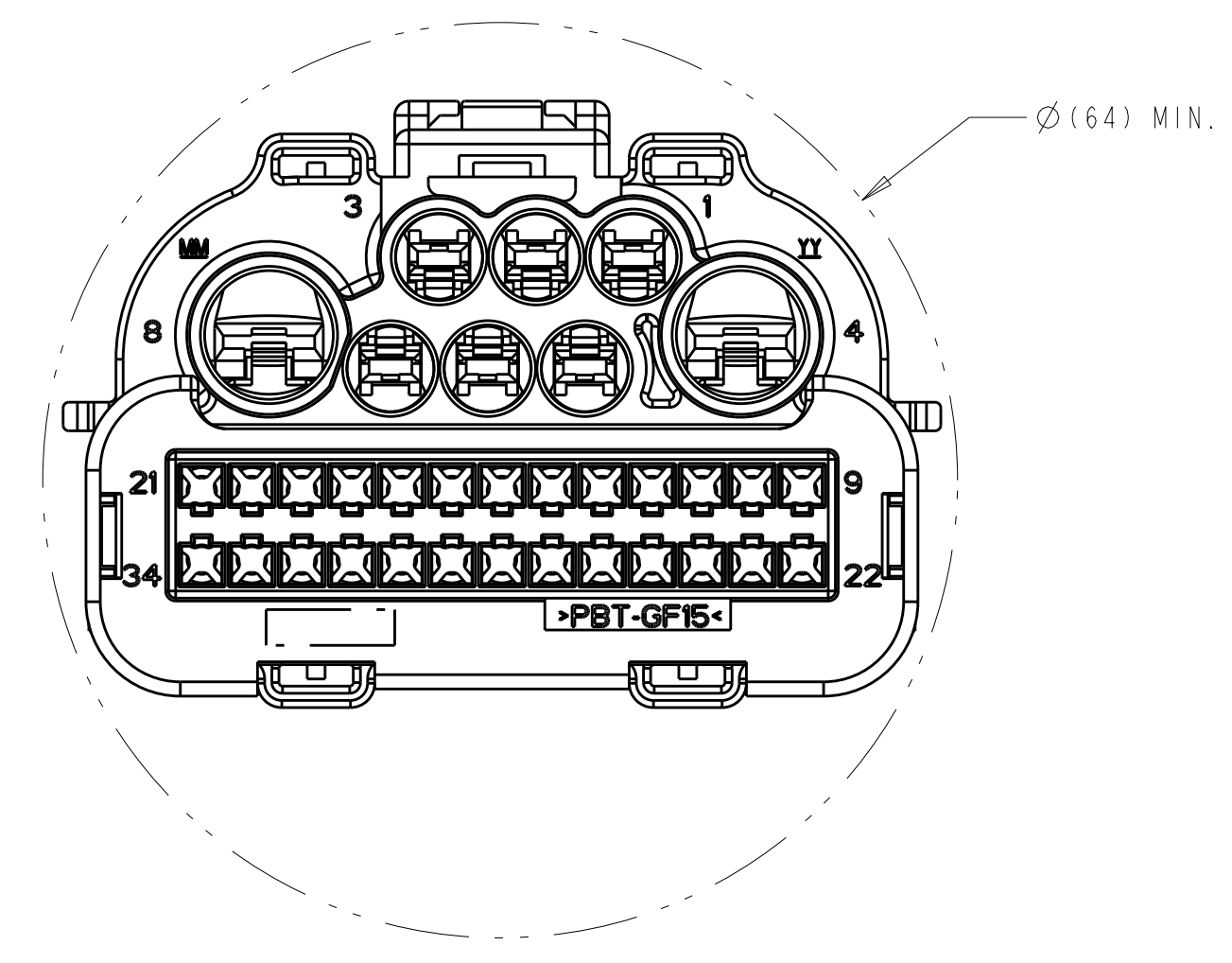
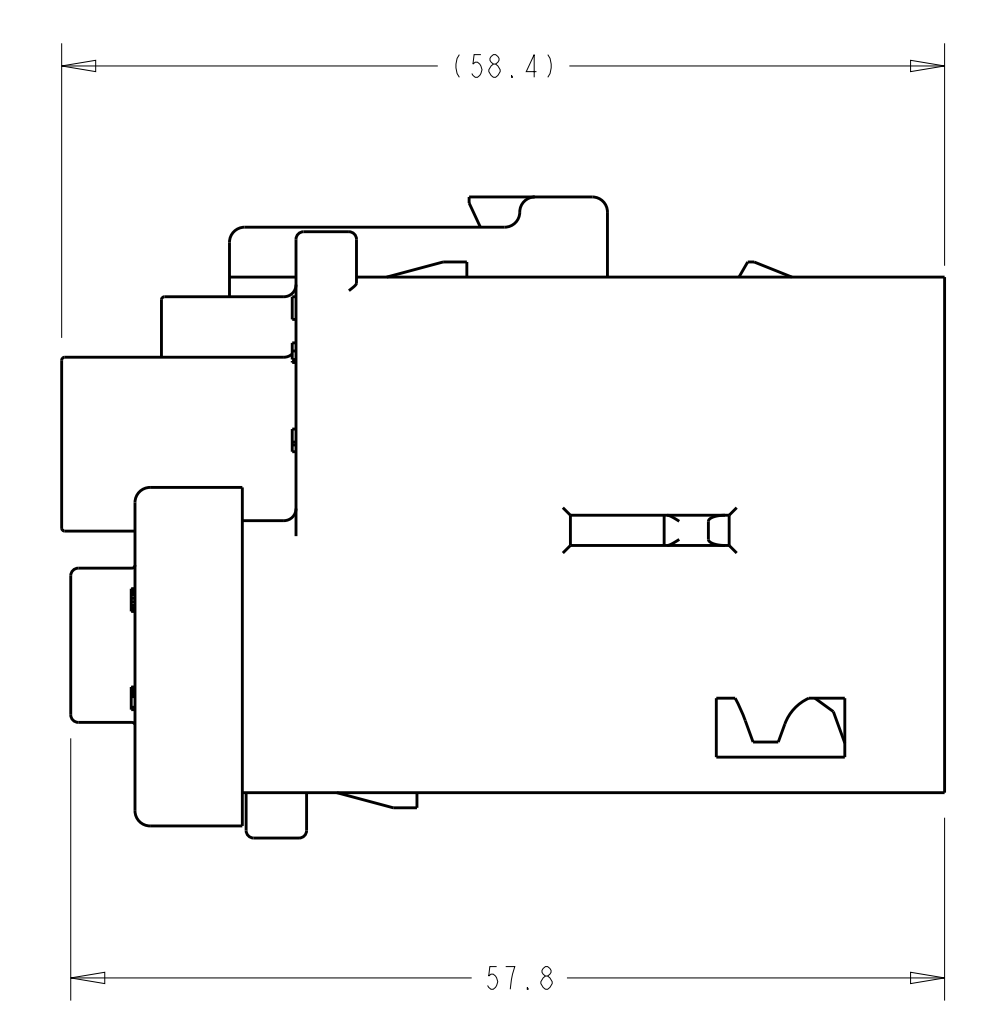
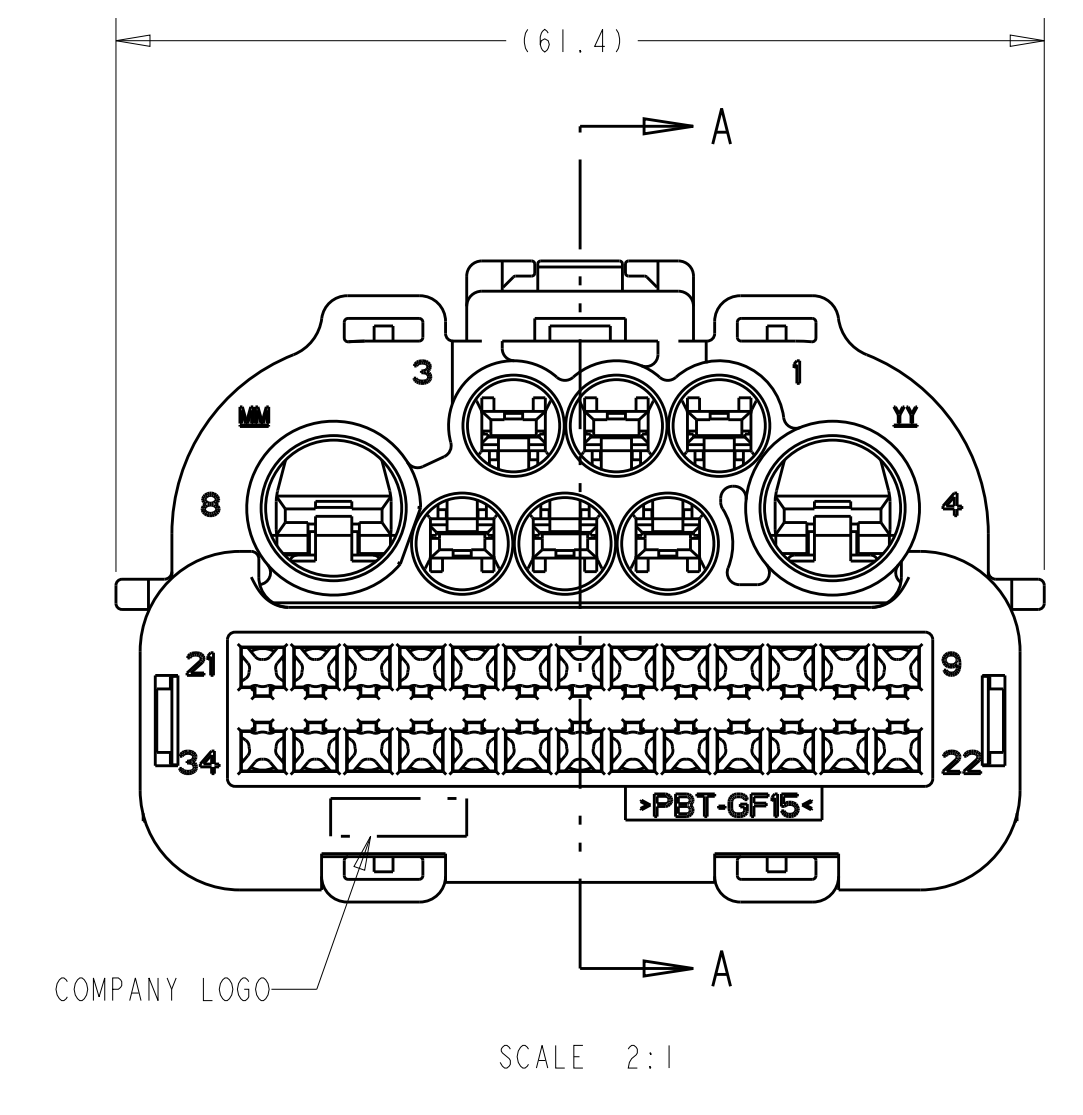

SCALE: 2:1
 MIN. FEED THRU CONDITION
 WITH 1mm CLEARANCE ALL AROUND

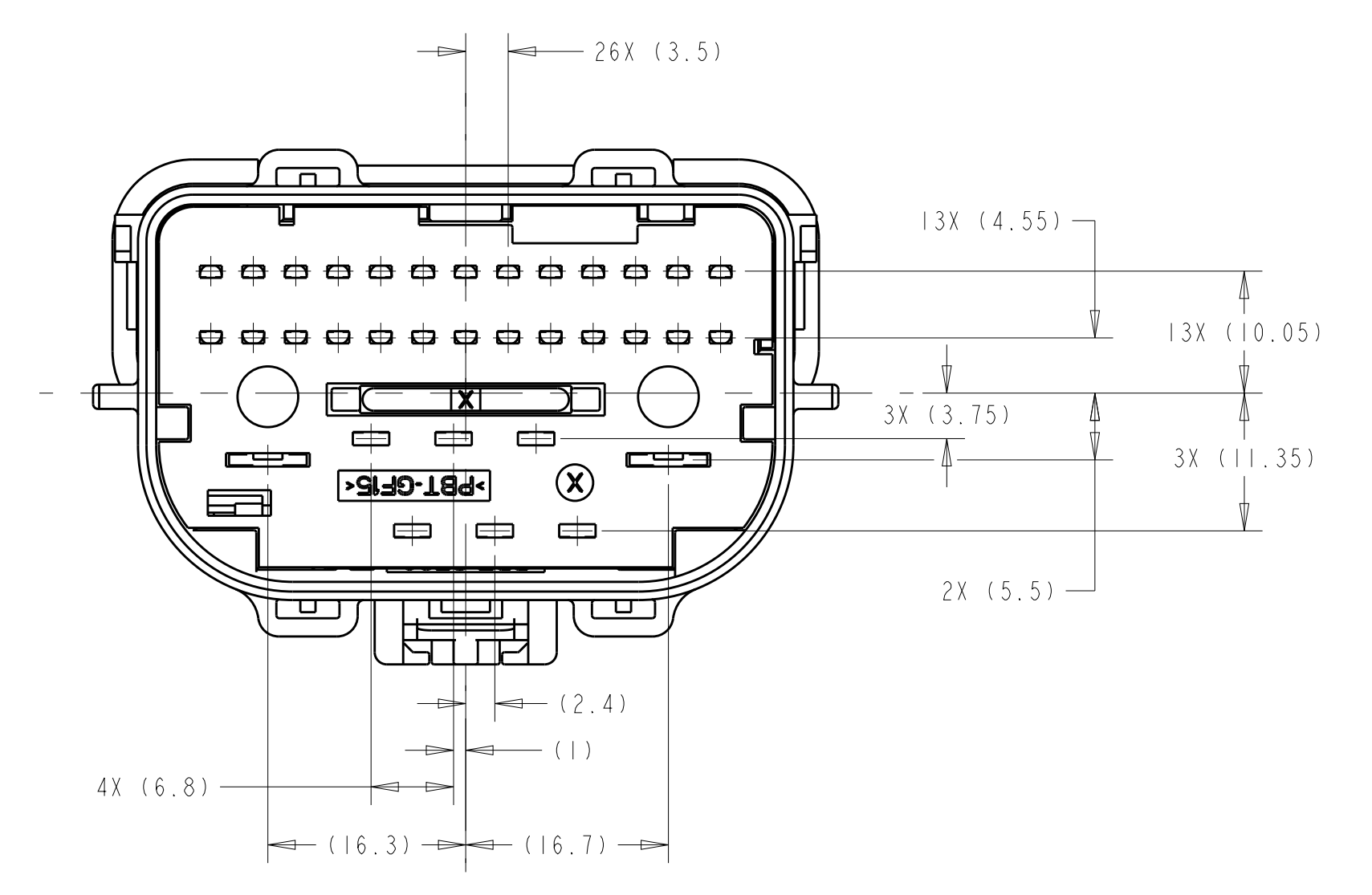
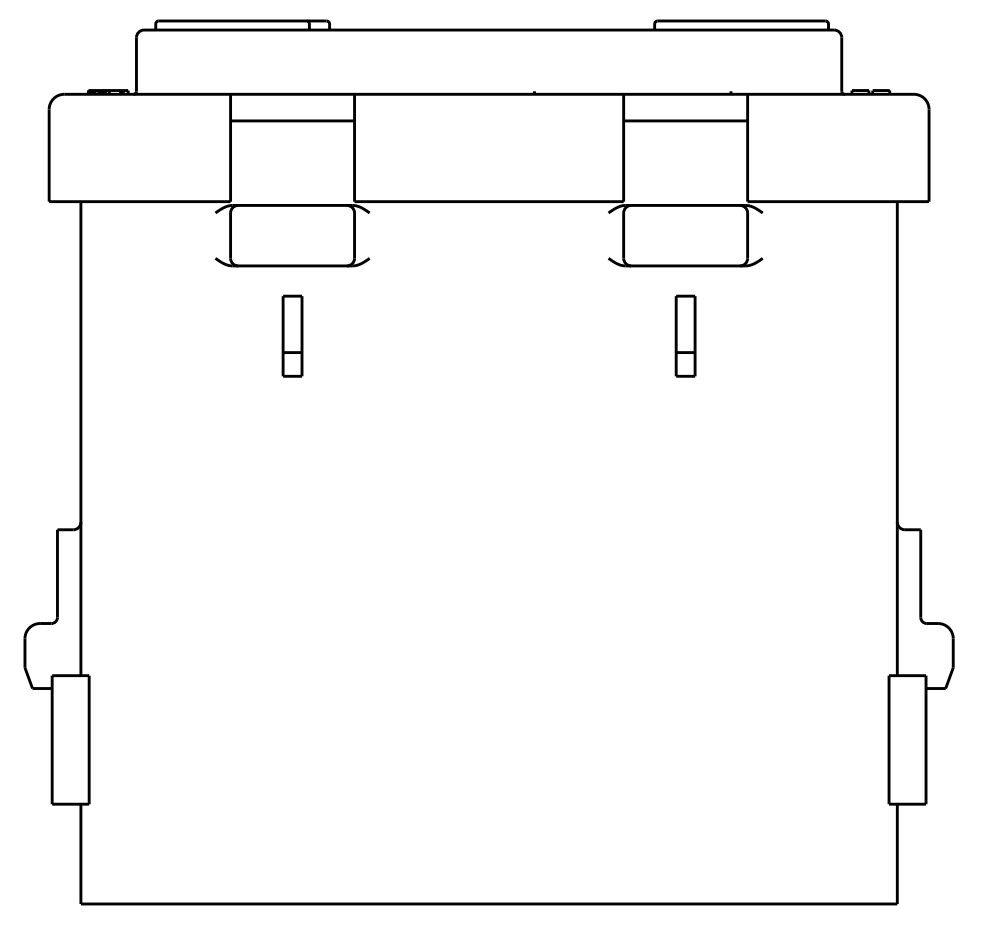

- PART MUST CONFORM TO THE USCAR-2 SPECIFICATION, DATED 07/DEC/00 (REVISION 3).
 - 0.2mm MAXIMUM RADIUS PERMISSIBLE ON EDGES AND FILLETS SHOWN AS SHARP FOR PLASTIC PARTS.
 - PRODUCTION DATE CODE (YYDD) AND ASSEMBLY PART NO. (LAST 3 DIGITS OF FORD/JLR PART NUMBER ACCEPTABLE) MUST BE LEGIBLE AND PERMANENTLY APPLIED WHEREVER PACKAGE SIZE PERMITS OR OTHER AGREEMENTS ARE MADE.
 - MATES WITH ASSEMBLY SHOWN ON DRAWING 1587041.
- ⚠ SEE TE CONNECTIVITY (TE) INSTRUCTION SHEET 408-8911 FOR PROPER POSITIONING OF TPA AND TE INSTRUCTION SHEET 408-8832 FOR APPLICATION USE OF CONNECTOR SYSTEM.
- ⚠ OBSOLETE PART
- ⚠ END SEAL COVER "ALL OPEN" IS PERMISSIBLE ONLY IN THE FOLLOWING ASSEMBLY NUMBERS: 1587042-1, 1587042-2 AND 1587042-3.

APPLICABLE COMPONENTS (FOR REFERENCE ONLY)				APPLICABLE WIRE SIZES (FOR REFERENCE ONLY)†	COMPONENT MATING PART NUMBER
DESCRIPTION	COLOR/PLATING	SUPPLIER	SUPPLIER PART NUMBER		
TERMINAL - MALE 1.5mm	TIN	MOLEX	33000-0002	16-20 AWG OR METRIC EQUIVALENT	33012-0002
TERMINAL - MALE 2.8mm	TIN	TYCO	1326031-2	20 AWG OR METRIC EQUIVALENT	1326032-2
TERMINAL - MALE 2.8mm	TIN	TYCO	1326031-3	18 AWG OR METRIC EQUIVALENT	1326032-3
TERMINAL - MALE 2.8mm	TIN	TYCO	1326031-4	16 AWG OR METRIC EQUIVALENT	1326032-4
TERMINAL - MALE 2.8mm	TIN	TYCO	1326031-5	14 AWG OR METRIC EQUIVALENT	1326032-5
TERMINAL - MALE 2.8mm	TIN	TYCO	1-1326031-1	12 AWG OR METRIC EQUIVALENT	1326032-6
CABLE SEAL - 2.8mm	GREEN	YAZAKI	7158-3111-60	1.2-1.9mm WIRE O.D.	N/A
CABLE SEAL - 2.8mm	YELLOW	YAZAKI	7158-3112-70	1.8-2.3mm WIRE O.D.	N/A
CABLE SEAL - 2.8mm	WHITE	YAZAKI	7158-3113-40	2.1-3.0mm WIRE O.D.	N/A
CABLE SEAL - 2.8mm	LT GRAY	YAZAKI	7158-3110-40	3.1-3.3mm WIRE O.D.	N/A
TERMINAL - MALE 6.3mm	TIN	YAZAKI	7114-4140-02	20-16 AWG OR METRIC EQUIVALENT	7116-4140-02
TERMINAL - MALE 6.3mm	TIN	YAZAKI	7114-4141-02	14 AWG OR METRIC EQUIVALENT	7116-4141-02
CABLE SEAL - 6.3mm	RED	YAZAKI	7158-3081-50	1.4-2.3mm WIRE O.D.	N/A
CABLE SEAL - 6.3mm	BLUE	YAZAKI	7158-3082-90	2.1-3.0mm WIRE O.D.	N/A
CABLE SEAL - 6.3mm	BLACK	YAZAKI	7158-3083	3.0-3.8mm WIRE O.D.	N/A

NOTE: SEE SUPPLIER DRAWINGS FOR LATEST INFORMATION AND CRIMP SPECIFICATIONS.

THIS DRAWING IS A CONTROLLED DOCUMENT. DATE: 15APR2003. DRAWN BY: N. SOCHI. CHECKED BY: T. DENILITE. DATE: 10JUN2003. REVISED BY: T. DENILITE. DATE: 16JUL2003. APPROVED BY: T. DENILITE. DATE: 16JUL2003.

TE Connectivity

34 WAY, SEALED, HYBRID, MALE

SCALE: 7:1 SHEET 1 OF 4 REV: 636

REVISIONS				
P	LV	DESCRIPTION	DATE	APPD
-	-	SEE SHEET 1	-	-

HARNESS KEYING OPTIONS
 SCALE 2X

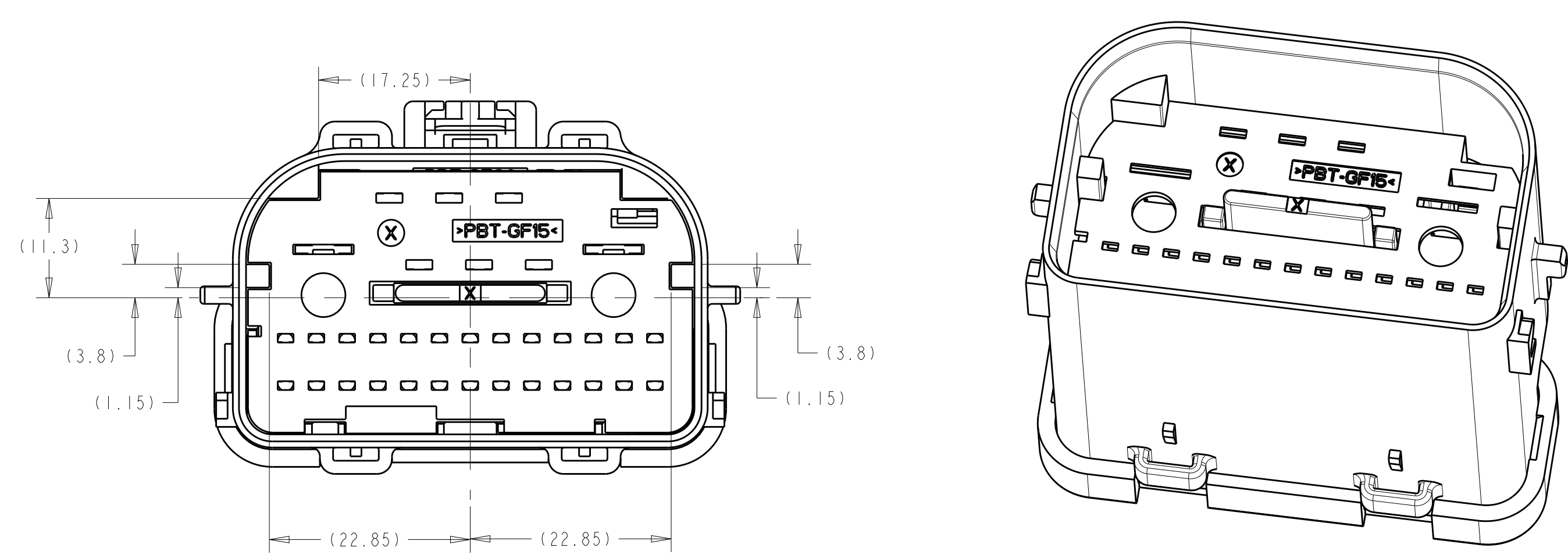
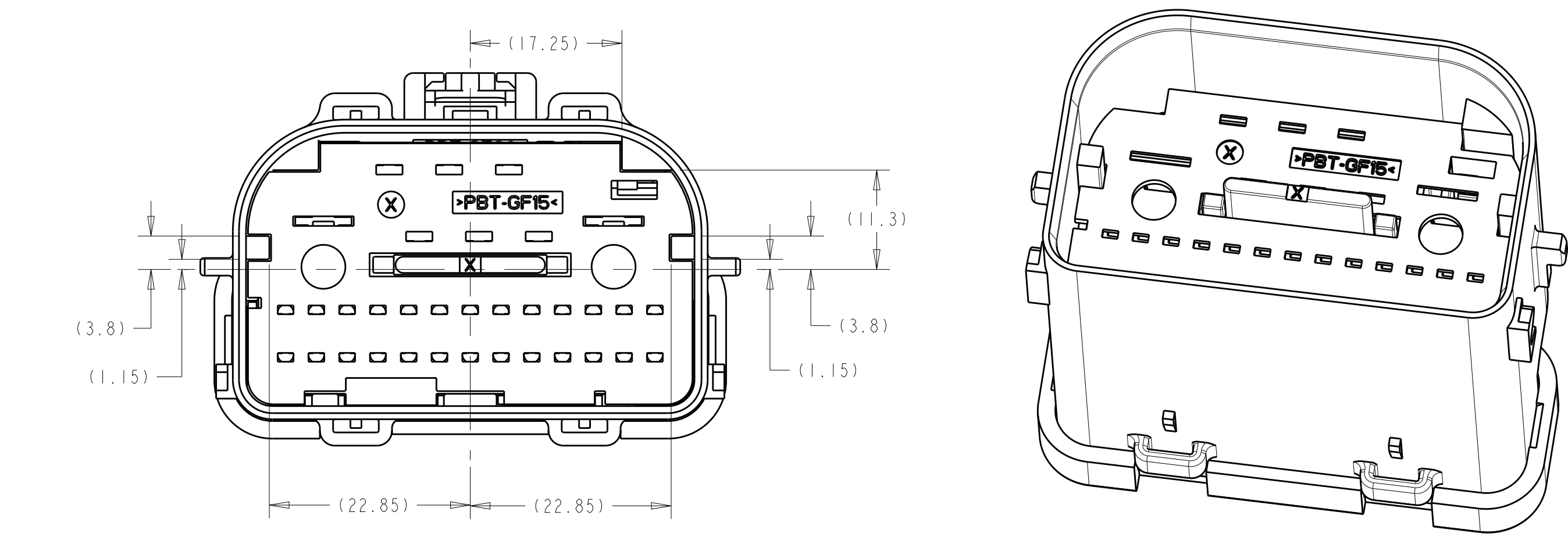
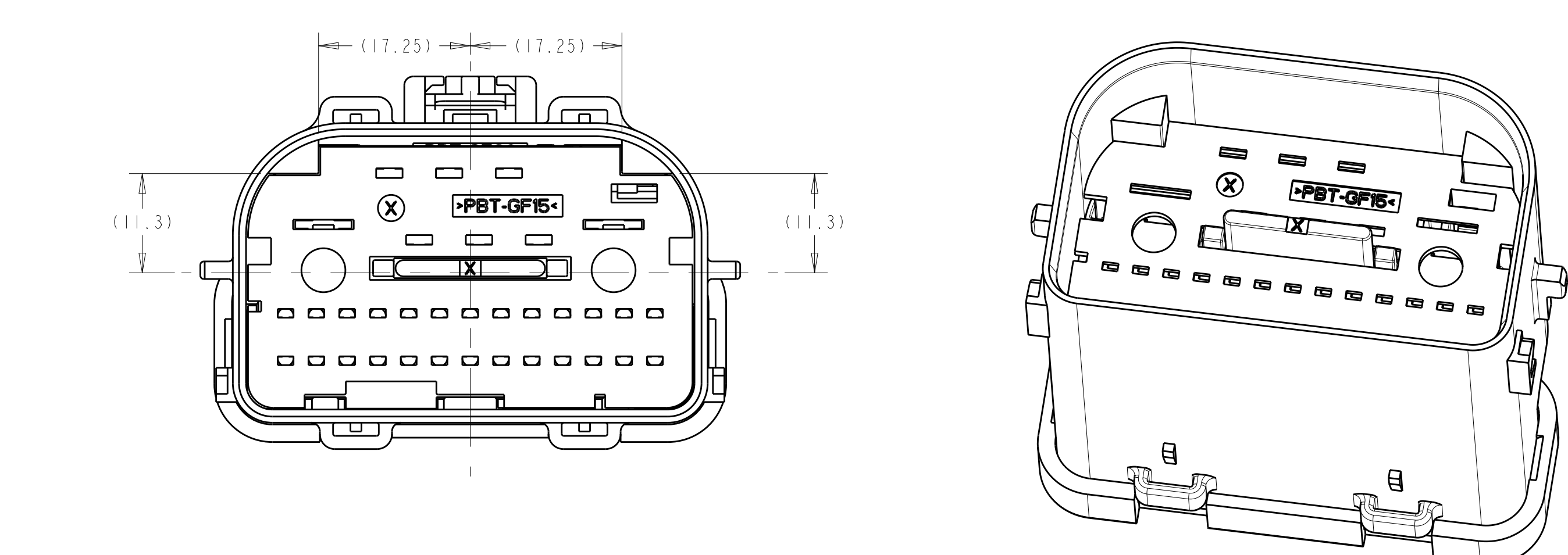
INDEX A	
INDEX B	
INDEX C	

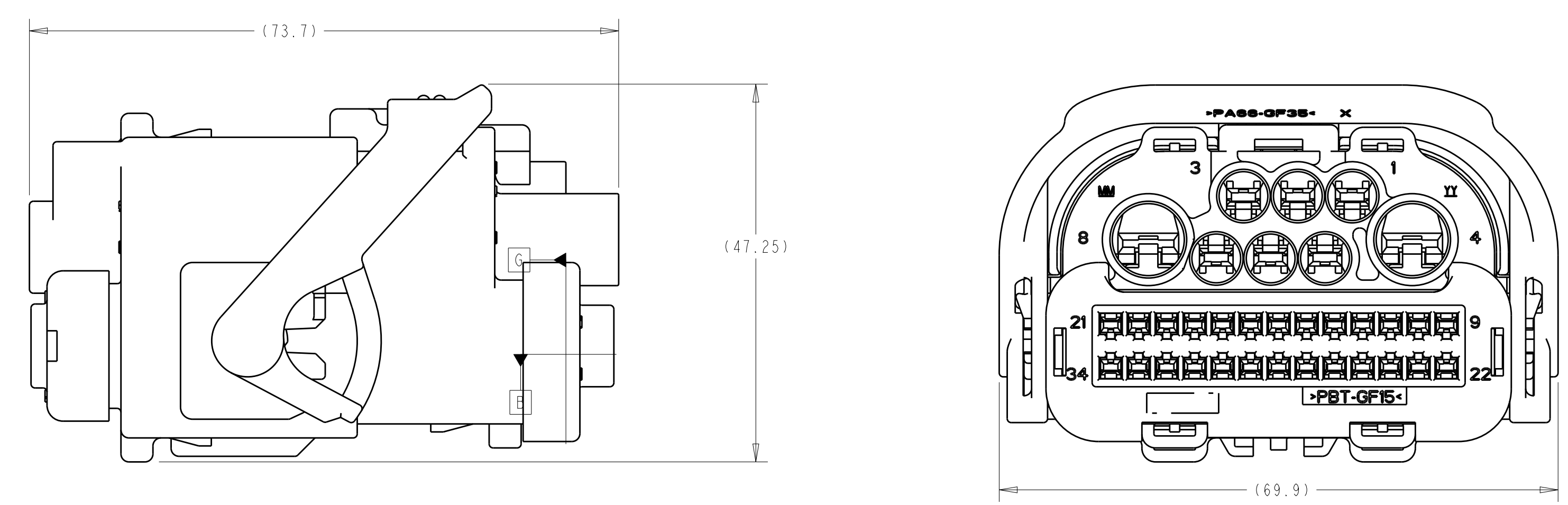
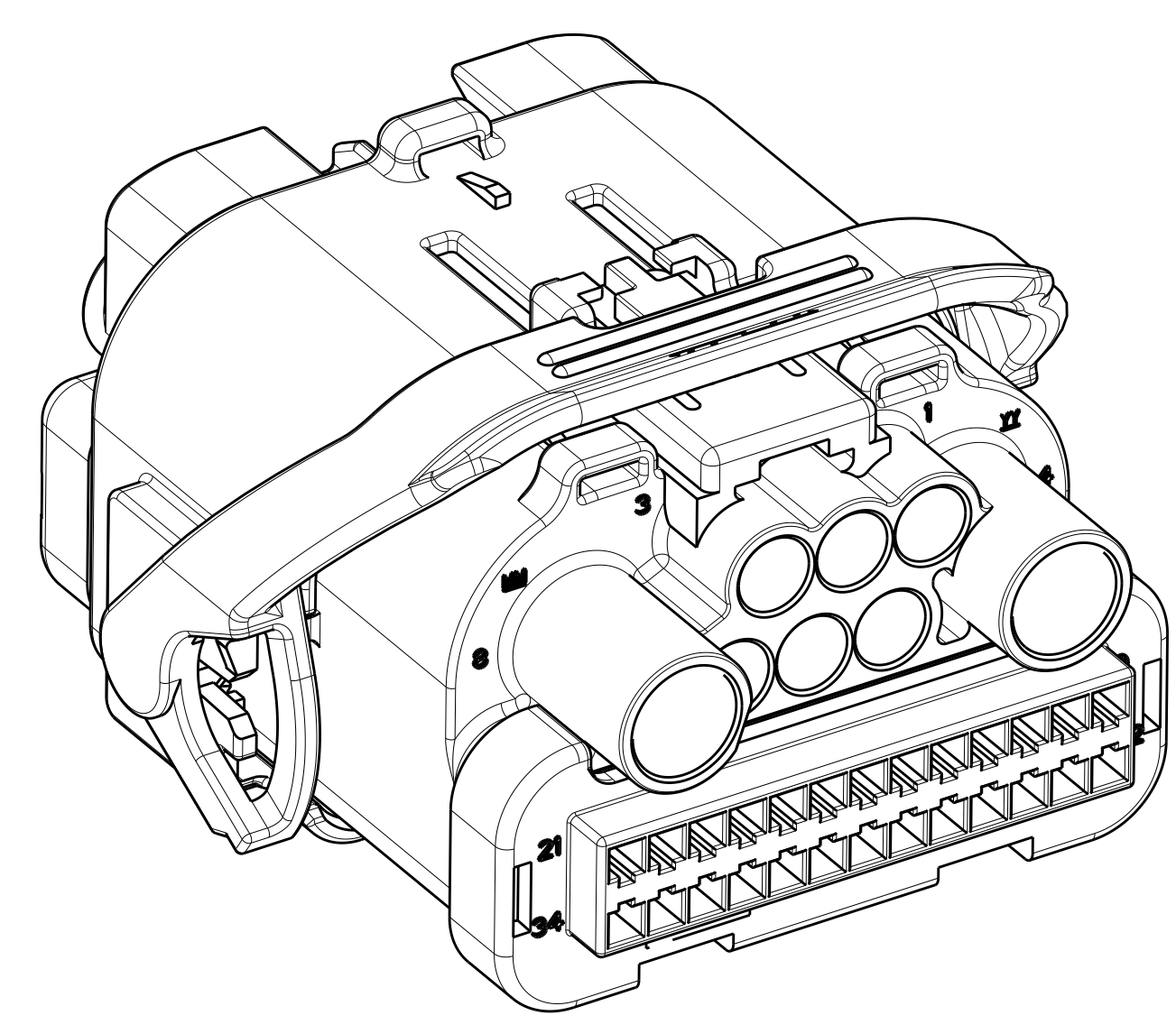

MATED ASSEMBLY
 SCALE 2:1

THIS DRAWING IS A CONTROLLED DOCUMENT.		DATE: 15APR2003	BY: N. SOOCH	TE Connectivity
DRAWN BY: N. SOOCH		DATE: 10JUN2003	CHK: T. DEWILLIE	
CHECKED BY: T. DEWILLIE		DATE: 16JUL2003	APPD: T. DEWILLIE	
DIMENSIONS: (mm)		PRODUCT SPEC:	NAME:	CAP ASSEMBLY, 34 WAY, SEALED, HYBRID, MALE
0 P/LC 85.3		APPLICATION SPEC:	SIZE:	A0
1 P/LC 85.3		WEIGHT:	CASE CODE:	00779
2 P/LC 85.1		CUSTOMER DRAWING:	DRAWING NO:	1587042
3 P/LC 85.1			SCALE:	7:1
4 P/LC 85.1			SHEET:	2 of 4
MATERIAL:			REV:	036
FINISH:				

REVISIONS			
REV	DATE	DESCRIPTION	BY
1		SEE SHEET 1	

TE CONNECTIVITY ASSEMBLY NUMBER		FORD PART NUMBER		JLR PART NUMBER		PIN OUT CHART	
8-1924425-4	...	GMCT-1A624-CA-144					
8-1924425-3	...	GMCT-1A624-CA-143					
8-1924425-2	...	GMCT-1A624-CA-142					
8-1924425-1	...	GMCT-1A624-CA-141					
8-1924425-0	...	GMCT-1A624-CA-140					
7-1924425-9	...	GMCT-1A624-CA-138					
7-1924425-8	...	GMCT-1A624-CA-137					
7-1924425-7	...	GMCT-1A624-CA-136					
7-1924425-6	...	GMCT-1A624-CA-135					
7-1924425-5	...	GMCT-1A624-CA-134					
7-1924425-4	...	GMCT-1A624-CA-133					
7-1924425-3	...	GMCT-1A624-CA-132					
7-1924425-2	...	GMCT-1A624-CA-131					
7-1924425-1	...	GMCT-1A624-CA-130					
7-1924425-0	...	GMCT-1A624-CA-129					
6-1924425-9	...	GMCT-1A624-CA-128					
6-1924425-8	...	GMCT-1A624-CA-128					
6-1924425-7	...	GMCT-1A624-CA-128					
6-1924425-6	...	GMCT-1A624-CA-128					
6-1924425-5	...	GMCT-1A624-CA-128					
6-1924425-4	...	GMCT-1A624-CA-128					
6-1924425-3	...	GMCT-1A624-CA-123					
6-1924425-2	...	GMCT-1A624-CA-122					
6-1924425-1	...	GMCT-1A624-CA-121					
6-1924425-0	...	GMCT-1A624-CA-120					
5-1924425-9	...	GMCT-1A624-CA-119					
5-1924425-8	...	GMCT-1A624-CA-118					
5-1924425-7	...	GMCT-1A624-CA-117					
5-1924425-6	...	GMCT-1A624-CA-116					
5-1924425-5	...	GMCT-1A624-CA-115					
5-1924425-4	...	GMCT-1A624-CA-114					
5-1924425-3	...	GMCT-1A624-CA-113					
5-1924425-2	...	GMCT-1A624-CA-112					
5-1924425-1	...	GMCT-1A624-CA-111					
5-1924425-0	...	GMCT-1A624-CA-110					

TE CONNECTIVITY ASSEMBLY NUMBER		FORD PART NUMBER		JLR PART NUMBER		PIN OUT CHART	
5-1587042-4	...	GMCT-1A624-CA-114					
5-1587042-3	...	GMCT-1A624-CA-114					
5-1587042-2	...	GMCT-1A624-CA-113					
5-1587042-1	...	GMCT-1A624-CA-112					
5-1587042-0	...	GMCT-1A624-CA-111					
4-1587042-9	...	GMCT-1A624-CA-110					
4-1587042-8	...	GMCT-1A624-CA-109					
4-1587042-7	...	GMCT-1A624-CA-108					
4-1587042-6	...	GMCT-1A624-CA-107					
4-1587042-5	...	GMCT-1A624-CA-106					
4-1587042-4	...	GMCT-1A624-CA-105					
4-1587042-3	...	GMCT-1A624-CA-104					
4-1587042-2	...	GMCT-1A624-CA-103					
4-1587042-1	...	GMCT-1A624-CA-102					
4-1587042-0	...	GMCT-1A624-CA-101					

TE CONNECTIVITY ASSEMBLY NUMBER		FORD PART NUMBER		JLR PART NUMBER		PIN OUT CHART	
0-1587042-4	...	GMCT-1A624-CA-101					
0-1587042-3	...	GMCT-1A624-CA-101					
0-1587042-2	...	GMCT-1A624-CA-101					
0-1587042-1	...	GMCT-1A624-CA-101					
0-1587042-0	...	GMCT-1A624-CA-101					

TERMINAL HOLE POSITION
 CAVITIES WITH A NUMERIC SYMBOL INDICATE CLOSED TERMINAL LOCATIONS
 BLANK CAVITIES INDICATE OPEN TERMINAL HOLE LOCATIONS
 PIN OUT CHART

TERMINAL HOLE POSITION
 CAVITIES WITH A NUMERIC SYMBOL INDICATE CLOSED TERMINAL LOCATIONS
 BLANK CAVITIES INDICATE OPEN TERMINAL HOLE LOCATIONS
 PIN OUT CHART

TERMINAL HOLE POSITION
 CAVITIES WITH A NUMERIC SYMBOL INDICATE CLOSED TERMINAL LOCATIONS
 BLANK CAVITIES INDICATE OPEN TERMINAL HOLE LOCATIONS
 PIN OUT CHART

THIS DRAWING IS A CONTROLLED DOCUMENT. DATE: 15APR2003. DRAWN BY: SOCHI. CHECKED BY: DENILITE. APPROVED BY: DENILITE. DIMENSIONS: (DIM). DIMENSIONS: 0.000. MATERIAL: 0.000. FINISH: 0.000. WEIGHT: 0.000. CUSTOMER DRAWING. SCALE: 7:1. SHEET: 4 OF 4. REV: 036.

STE TE Connectivity
 CAP ASSEMBLY, 34 WAY, SEALED, HYBRID, MALE

X-ON Electronics

Largest Supplier of Electrical and Electronic Components

Click to view similar products for [Automotive Connectors](#) category:

Click to view products by [TE Connectivity](#) manufacturer:

Other Similar products are found below :

[003-018-000](#) [60403001](#) [60993906-B](#) [M902-2131](#) [M902-2161](#) [72.330.1035.1](#) [73.353.4028.0](#) [F119300-B](#) [F166900](#) [F258300-B](#) [F358300-B](#)
[F407400](#) [F444110](#) [F487000](#) [F509500B-B](#) [827153-1](#) [8N1515-32-24P](#) [9-1326729-8](#) [925474-1](#) [928905-1](#) [964562-4](#) [968782-1](#) [GT17SA-8DS-](#)
[HU](#) [98891-1012](#) [98947-1016](#) [12004147](#) [12004475-L](#) [12010290](#) [12010309-B](#) [12015454](#) [12020219-B](#) [12020308](#) [12041318-B](#) [12052225-L](#)
[12052466](#) [12059125](#) [12064869](#) [12004327-B](#) [12010503-B](#) [12015308](#) [12015384](#) [12015909](#) [1-21030-1](#) [12041254](#) [12041318](#) [12047946-B](#)
[12047957](#) [12047957-L](#) [12059473](#) [12066261](#)