

THIS DRAWING IS UNPUBLISHED. RELEASED FOR PUBLICATION OCT ,2001.
 © COPYRIGHT 2001 BY TYCO ELECTRONICS CORPORATION. ALL RIGHTS RESERVED.

LOC	DIST	REVISIONS			
P	LTR	DESCRIPTION	DATE	DWN	APVD
J	/				
	D1	ECR-10-014669	13JUL10	B.W	S.Y

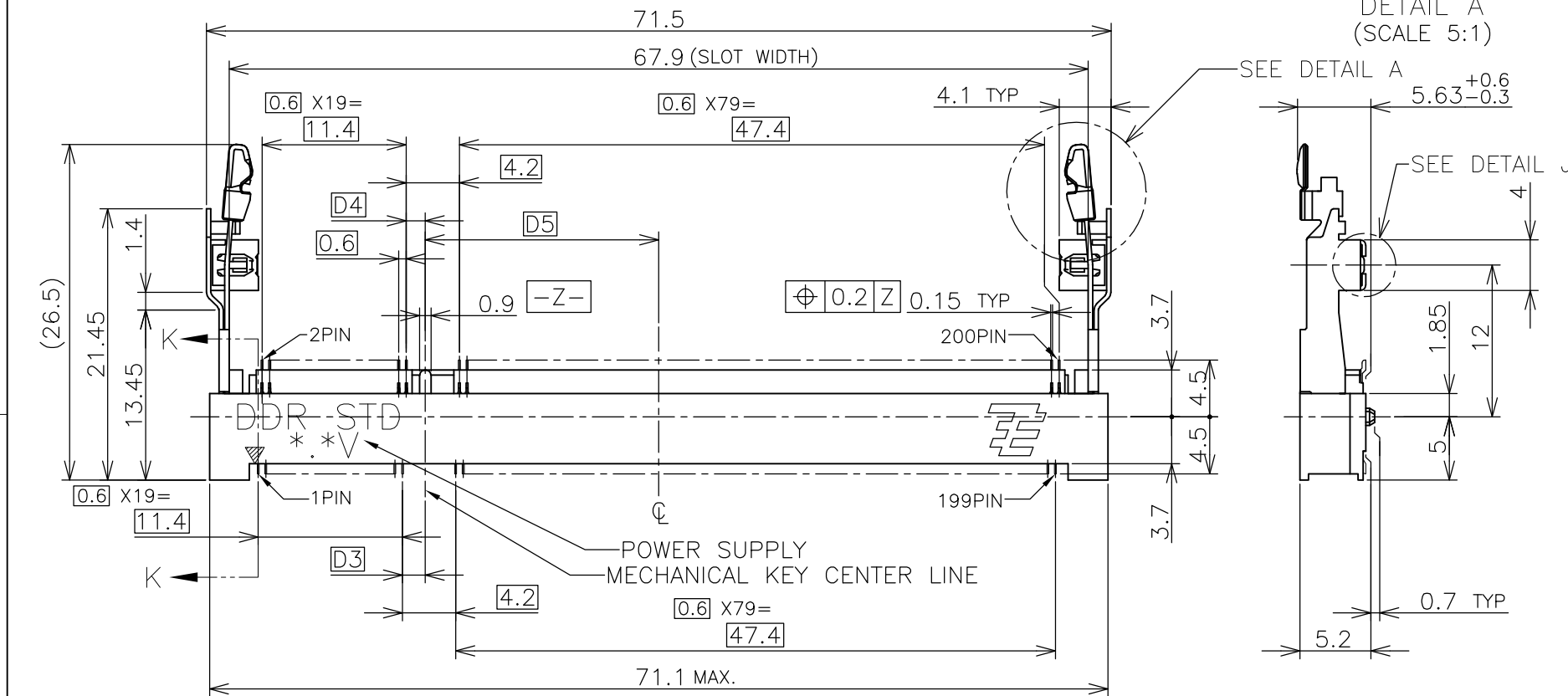

- (APPLIED TO SHEET 1-2)
- MATERIAL ; HOUSING: HIGH TEMPERATURE THERMO PLASTIC UL94V-0
 CONTACT: COPPER ARROY
 LOCK LEVER STAINLESS STEEL
 SOLDER PEG: COPPER ARROY
 - FINISH ; CONTACT AREA: GOLD FLASH ON 0.0013MIN ALL OVER NICKEL.
 SOLDERING AREA: GOLD FLASH PLT.
 SOLDER PEG: TIN LEAD OR TIN PLATING.
- MECHANICAL KEY POSITION OF CONNECTOR SEE TABLE.
 - TOLERANCES NON-CUMULATIVE.
 - NOT TO SCALE.
 - INSIDE MUST BE RESIST COAT EXCEPT SOLDER PATTERN.
7. IF THE MODULE DOESN'T INSERT AND LOCK IN THE LATCH SMOOTHLY, OPEN WIDE BOTH LATCHES BY MANUAL. AND THE MODULE MUST BE INSERTED AND LOCKED IN THE LATCH.

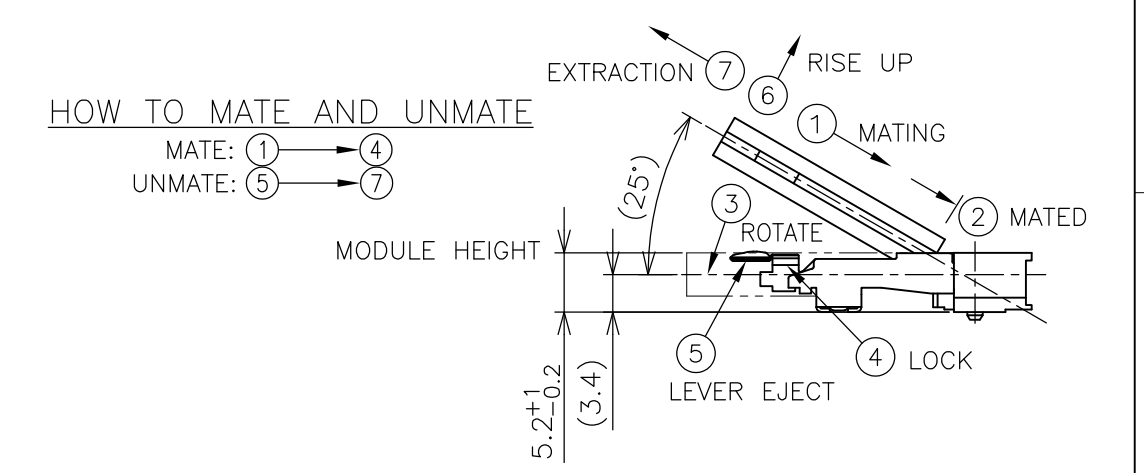
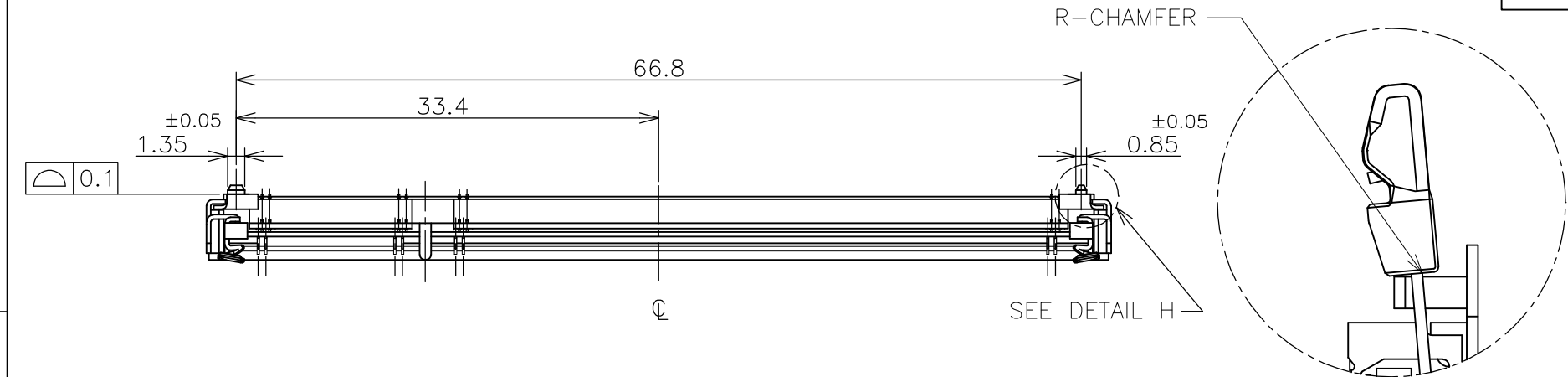
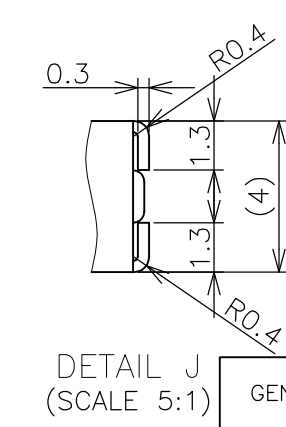
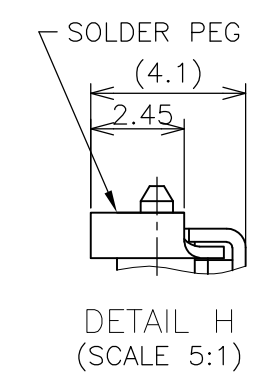
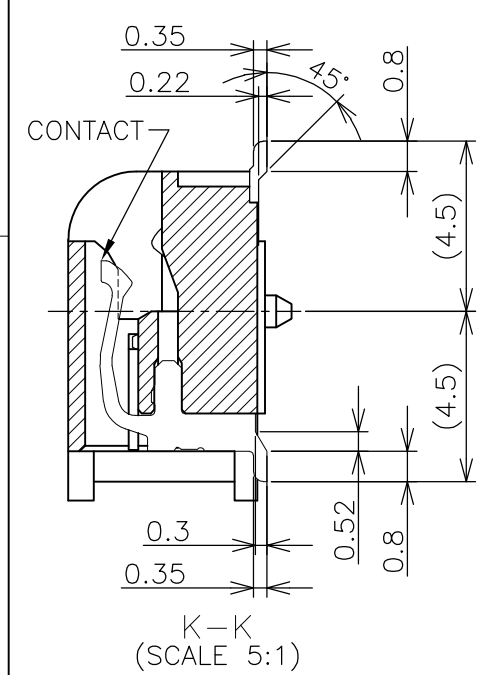

GENERAL TOLERANCE
 10 ≥ : ±0.2
 30 ≥ > 10 : ±0.25
 100 ≥ > 30 : ±0.3
 ANGLES : ±3°

TIN PLATING (LEAD FREE)	AVAILABLE	2.5V (DDR1)	18.45	1.5	1.8	200	1612507-3
TIN LEAD PLATING	AVAILABLE	2.5V (DDR1)	18.45	1.5	1.8	200	1612507-1
REMARK (PEG)	TOOLING STATUS	POWER SUPPLY	D5	D4	D3	POS	PART NO.
THIS DRAWING IS A CONTROLLED DOCUMENT.		DWN B.WONG 16JUL10	Tyco Electronics AMP K.K. Kawasaki, Japan				
DIMENSIONS: MM		CHK C.WANG 16JUL10					
TOLERANCES UNLESS OTHERWISE SPECIFIED:		APVD S.YAO 16JUL10					
MATERIAL		PRODUCT SPEC 108-5701	NAME				
		APPLICATION SPEC	DDR SODIMM SOCKET 200P STANDARD PROFILE STANDARD TYPE				
		WEIGHT 4.7g	SIZE A3	CAGE CODE 00779	DRAWING NO C-1612507	RESTRICTED TO	
CUSTOMER DRAWING			SCALE 2:1	SHEET 1 OF 4	REV D1		

THIS DRAWING IS UNPUBLISHED. RELEASED FOR PUBLICATION OCT., 2001.
 © COPYRIGHT 2001 BY TYCO ELECTRONICS CORPORATION. ALL RIGHTS RESERVED.

LOC	DIST	REVISIONS			
P	LTR	DESCRIPTION	DATE	DWN	APVD
		SEE SHEET 1	-	-	-

REFERENCE P.C.BOARD PATTERN LAYOUT (CONNECTOR MOUNTING SIDE)

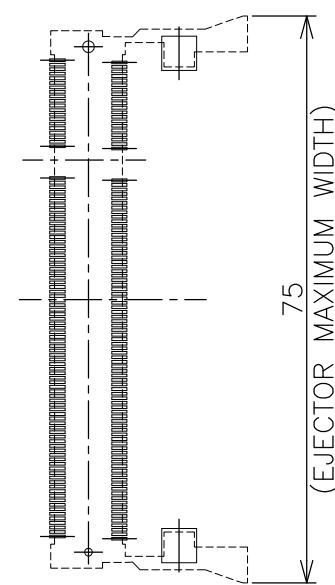

REAL SIZE (SCALE 1:1)

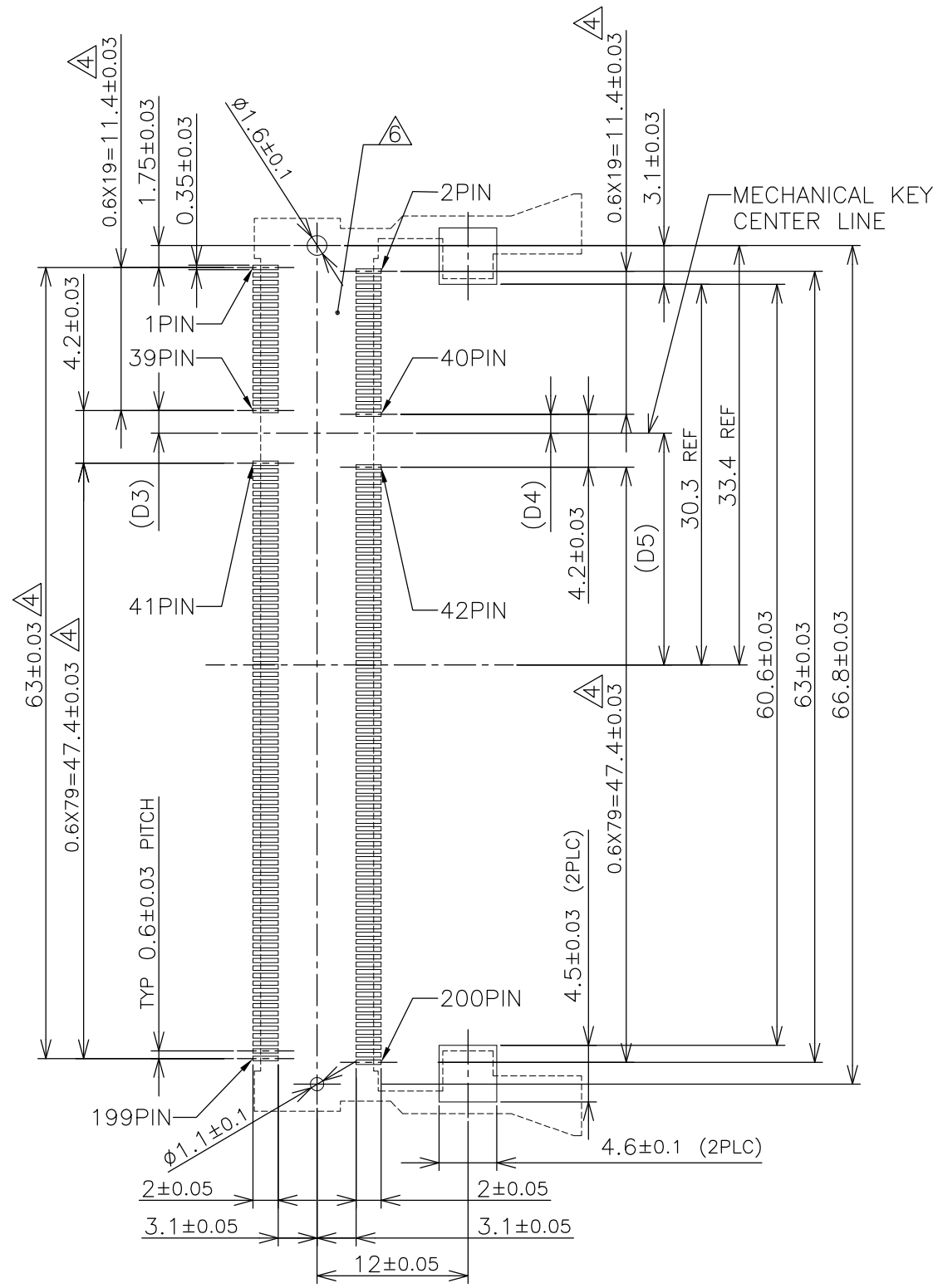

1.8V	17.55	2.4	2.7
2.5V	18.45	1.5	1.8
POWER SUPPLY	D5	D4	D3

THIS DRAWING IS A CONTROLLED DOCUMENT.		DWN	Tyco Electronics AMP K.K. Kawasaki, Japan			
DIMENSIONS: MM		CHK				
TOLERANCES UNLESS OTHERWISE SPECIFIED:		APVD	NAME			
0 PLC ± 1 PLC ± 2 PLC ± 3 PLC ± 4 PLC ± ANGLES ± FINISH ±		PRODUCT SPEC	DDR SODIMM SOCKET 200P STANDARD PROFILE STANDARD TYPE			
MATERIAL		APPLICATION SPEC	SIZE	CAGE CODE	DRAWING NO	RESTRICTED TO
		WEIGHT	A3	00779	C-1612507	-
CUSTOMER DRAWING			SCALE	SHEET	OF	REV
			2:1	2	4	D1

THIS DRAWING IS UNPUBLISHED. RELEASED FOR PUBLICATION OCT. 2001.
 © COPYRIGHT 2001 BY TYCO ELECTRONICS CORPORATION. ALL RIGHTS RESERVED.

LOC	DIST	REVISIONS			
P	LTR	DESCRIPTION	DATE	DWN	APVD
J	/	SEE SHEET 1	-	-	-

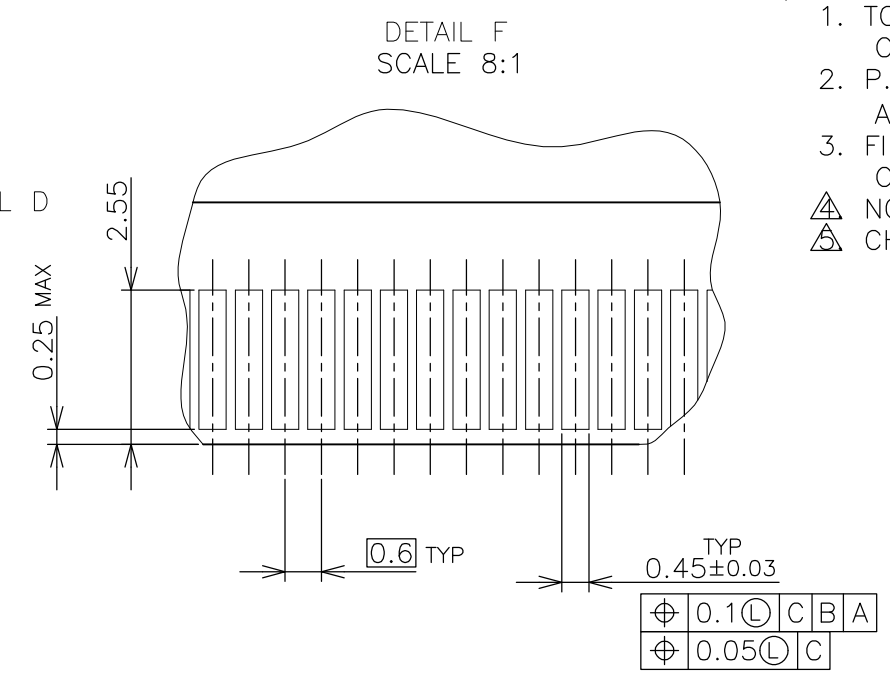
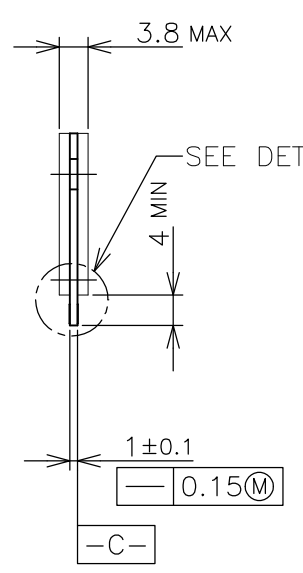
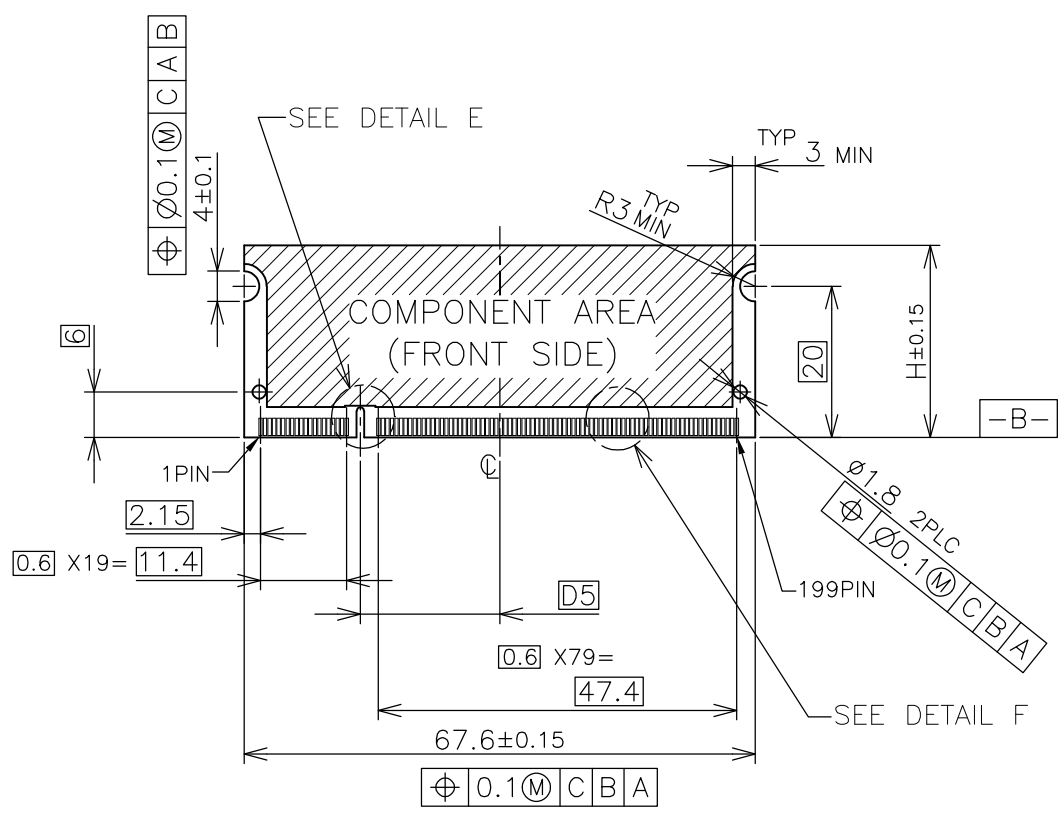

- (APPLIED TO SHEET 3)
1. TOLERANCES ON ALL DIMENSIONS ±0.15 UNLESS OTHERWISE SPECIFIED.
 2. P.C. BOARD THICKNESS APPLIES ACROSS TABS AND INCLUDES PLATING AND/OR METALIZATION.
 3. FINISH OF PAD : GOLD PLATING 0.00076 MIN. OVER Ni PLATING 0.002MIN.
- △ NO BURR
 ▽ CHAMFER 0.25 MAX x 45° IF EXIST.

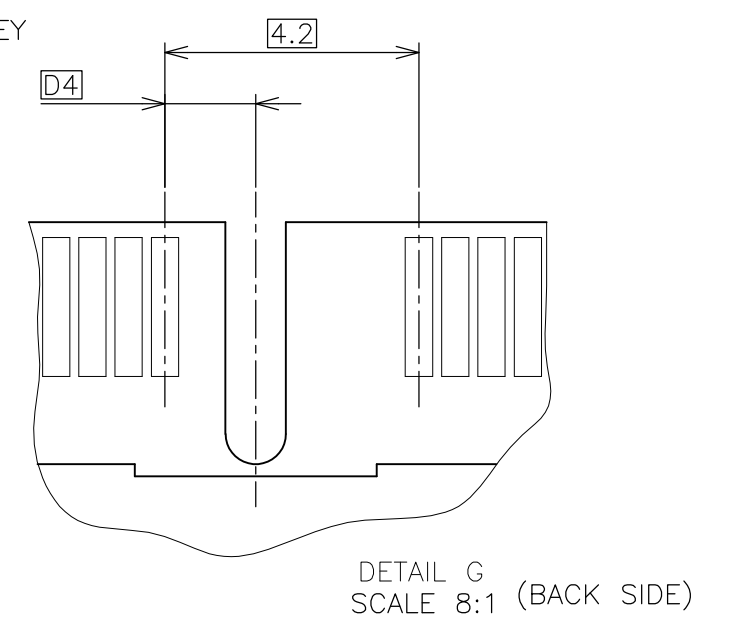
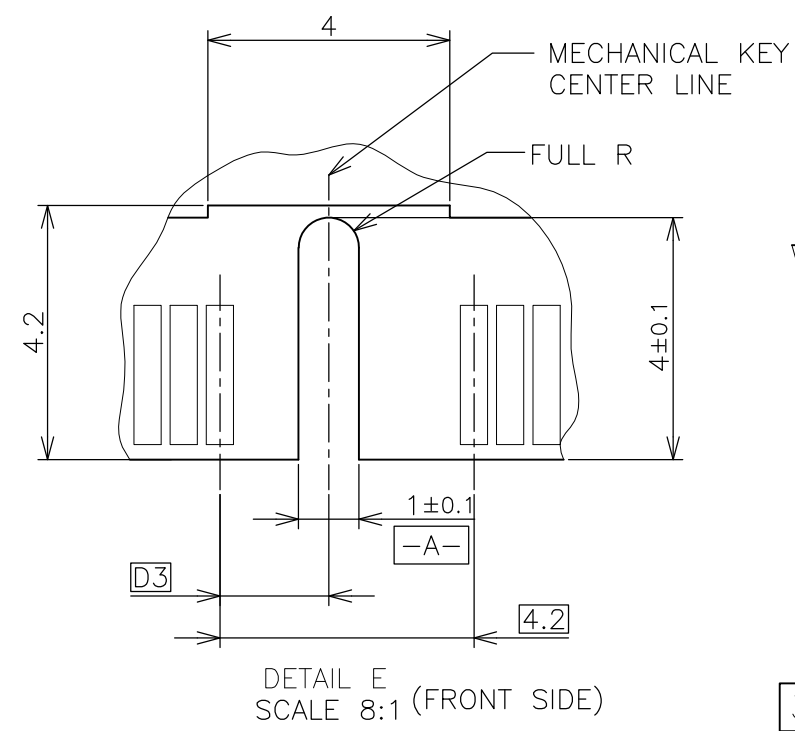
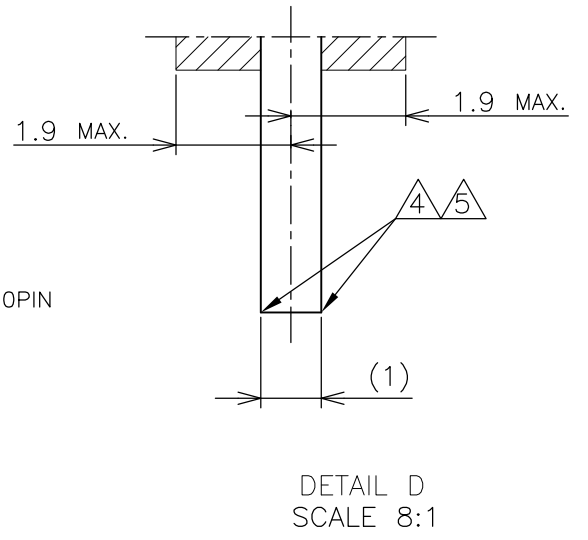
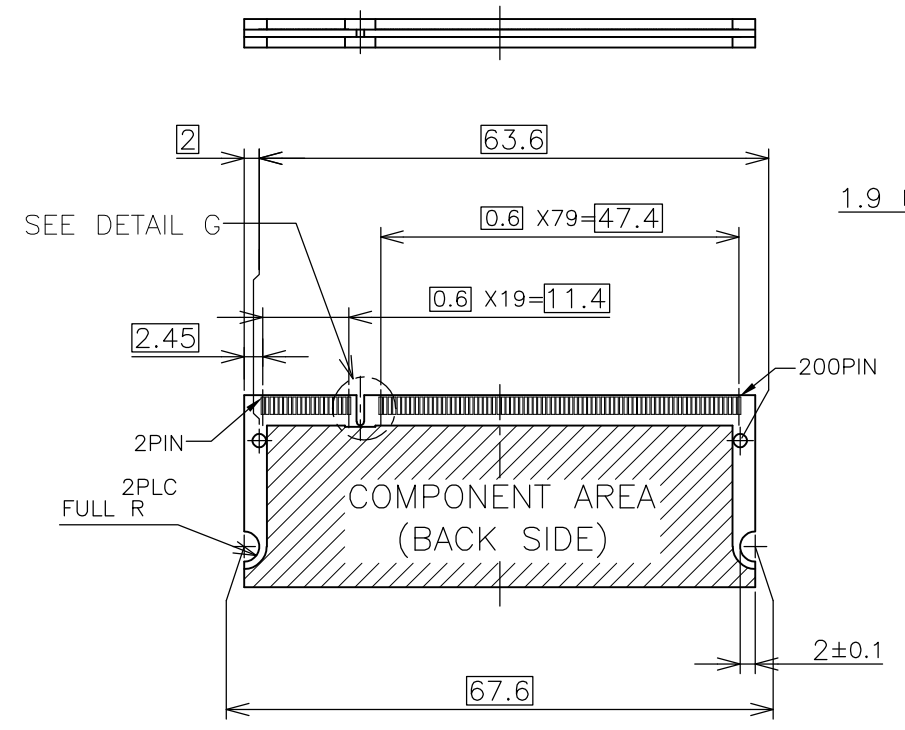

RECOMMENDED MATING P.C.B CONFIGURATION

THIS DRAWING IS A CONTROLLED DOCUMENT.		DWN	Tyco Electronics AMP K.K. Kawasaki, Japan			
DIMENSIONS: MM		CHK	NAME			
TOLERANCES UNLESS OTHERWISE SPECIFIED:		APVD	PRODUCT SPEC			
0 PLC ±		PRODUCT SPEC	APPLICATION SPEC			
1 PLC ±		APVD	SCALE			
2 PLC ±		APVD	CAGE CODE			
3 PLC ±		APVD	DRAWING NO			
4 PLC ±		APVD	RESTRICTED TO			
ANGLES ±		APVD	A3 00779 C-1612507			
FINISH		APVD	CUSTOMER DRAWING			
MATERIAL		APVD	SCALE 2:1 SHEET 3 OF 4 REV D1			

THIS DRAWING IS UNPUBLISHED. RELEASED FOR PUBLICATION OCT , 2001.
 © COPYRIGHT 2001 BY TYCO ELECTRONICS CORPORATION. ALL RIGHTS RESERVED.

LOC	DIST	REVISIONS					
		P	LTR	DESCRIPTION	DATE	DWN	APVD
J	—	—	—	SEE SHEET 1	—	—	—

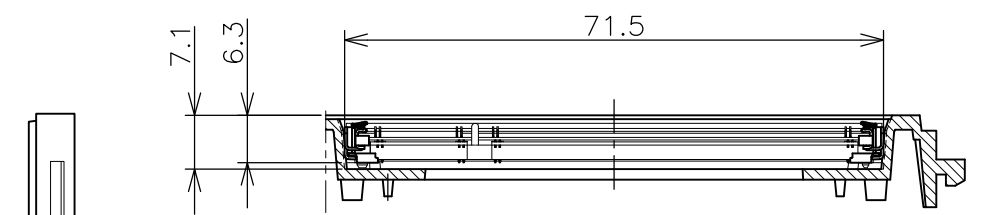
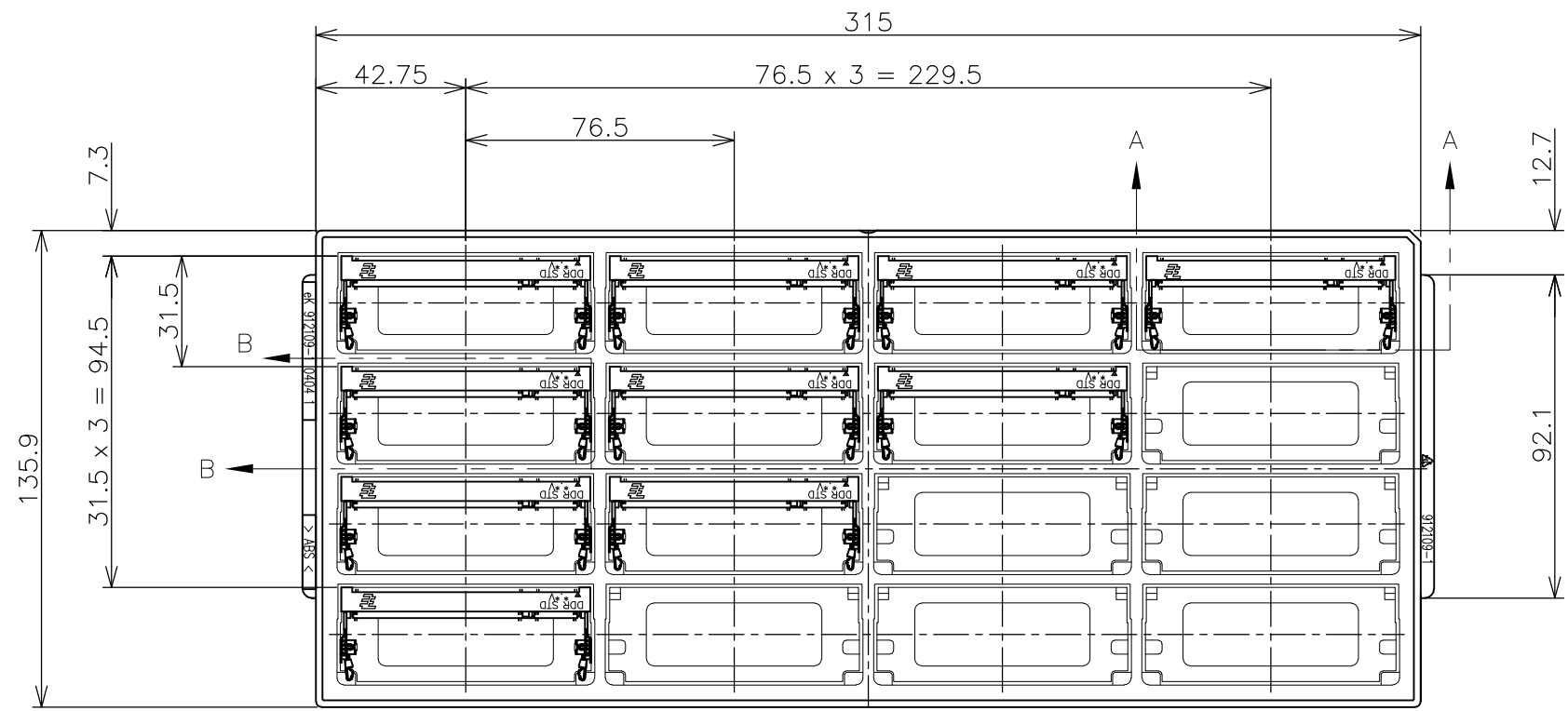

A-A
SCALE 1:1

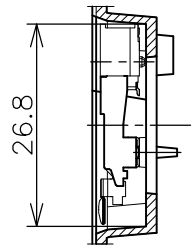

B-B
SCALE 1:1

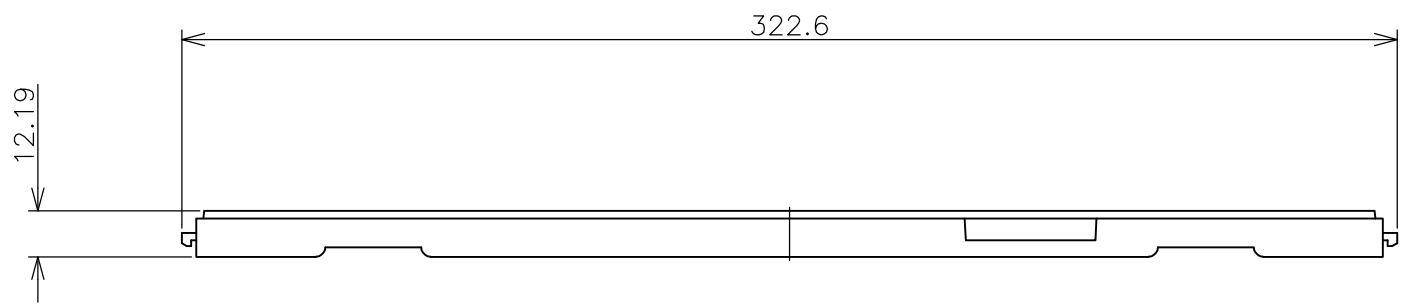

TIN PLATING	16EA/TRAY	1612507-3
TIN LEAD PLATING		1612507-1
REMARK (PEG)	QTY	P/N

- (APPLIED TO SHEET 4)
1. THE DIRECTION OF EACH CONNECTOR ON A TRAY IS REFERRED TO THIS DRAWING.
 2. GENERAL TOLERANCE: ±0.5

THIS DRAWING IS A CONTROLLED DOCUMENT.		DWN		Tyco Electronics AMP K.K. Kawasaki, Japan	
DIMENSIONS: MM		CHK			
TOLERANCES UNLESS OTHERWISE SPECIFIED:		APVD		NAME	
0 PLC ± 1 PLC ± 2 PLC ± 3 PLC ± 4 PLC ± ANGLES ±		PRODUCT SPEC		DDR SODIMM SOCKET 200P STANDARD PROFILE STANDARD TYPE	
MATERIAL		FINISH		RESTRICTED TO	
		WEIGHT		SIZE CAGE CODE DRAWING NO	
		CUSTOMER DRAWING		A3 00779 C-1612507	
		SCALE 1:2		SHEET 4 OF 4 REV D1	

X-ON Electronics

Largest Supplier of Electrical and Electronic Components

Click to view similar products for [DIMM Connectors](#) category:

Click to view products by [TE Connectivity](#) manufacturer:

Other Similar products are found below :

[1-1932649-2](#) [1-1761024-0](#) [2309411-5](#) [296409204002856+](#) [10116658-252ASLF](#) [5390471-1](#) [2309413-3](#) [78507-0061](#) [KIT-SODIMM-1X16GB/01](#) [10129206-0010013LF](#) [10086891-052TSLF](#) [10079192-11102LF](#) [10116658-152FSLF](#) [10129206-0011113LF](#) [1-2308107-0](#) [2013310-1](#) [2013289-1](#) [390111-1](#) [390112-1](#) [2309413-1](#) [2309407-1](#) [2309414-1](#) [10081530-12208LF](#) [151080-0001](#) [78726-1004](#) [10005639-11107LF](#) [10005639-11109LF](#) [10005639-12207LF](#) [10023061-10207LF](#) [10033853-252FSLF](#) [10033853-052ASLF](#) [10033853-052FSLF](#) [10033853-152FSLF](#) [10033854-052FSLF](#) [10034542-10002LF](#) [10037402-12207LF](#) [10081530-11107LF](#) [10081530-12207LF](#) [10081530-12218LF](#) [10081530-12228LF](#) [10124632-0030001LF](#) [10124806-01006LF](#) [10145226-0241N13LF](#) [59354-052FSLF](#) [59355-052FSLF](#) [DDR4288S0211TF](#) [DDR4288S0511H](#) [DDR4288S0511TF](#) [DDR4288V0123TF](#) [DDR4288V0213TF](#)