

4

3

2

1

This drawing involves proprietary design rights of Tyco Electronics Corporation, and all design, manufacture, reproduction, use and sale rights regarding the same are expressly reserved. It is submitted for a specific purpose and the recipient by accepting this drawing, assumes custody and control and agrees to take reasonable precautions: (a) that this drawing will not be copied and reproduced, in whole or in part, or its contents revealed in any manner, or to any person except to meet the purpose for which it was delivered and (b) that any special features peculiar to this design will not be incorporated in other projects without the expressed written permission of Tyco Electronics Corporation.

## REVISIONS

EC	REV	DESCRIPTION	DATE
CPR	A	NEW RELEASE	03/04/06

## TYPICAL SPECIFICATION TABLE

POSITION	CONTACT SIZE	RATING	VOLTAGE RATING
1 - 3	#16	15 AMPERES	250 VOLTS
4 - 19	#20	5 AMPERES	250 VOLTS
20 - 22	#16	15 AMPERES	250 VOLTS

6. ITEMS PROVIDED TO THIS SPECIFICATION TO BE PERMANENTLY IDENTIFIED PER THE FOLLOWING IDENTIFIER:

YEAR  WEEK

TYCO PART NUMBER      DATE CODE (e.g. 0625)

XXXXXXX-X      XXXX

5. ALL DIMENSIONS SHOWN ACROSS A CENTERLINE (⌀) SHALL BE CENTRALIZED WITHIN THE TOLERANCE INDICATED FOR THAT DIMENSION.

4. A REFERENCE DIMENSION (XXX) IS WITHOUT TOLERANCE AND USED FOR INFORMATION PURPOSE ONLY.

3. RECOMMENDED MOUNTING HARDWARE: TO BE ORDERED SEPARATELY.

- FOR PANEL MOUNTING, USE

1650402-1: SHOULDER SCREW, #8-32

1650106-1: SHOULDER SCREW, #6-32

1650589-1: SHOULDER SCREW, M4X0.7

- FOR PCB MOUNTING, USE COMMERCIALY AVAILABLE SCREW AND WASHER (IF REQUIRED).

2. MATERIALS:

HOUSING: THERMOPLASTIC, GLASS REINFORCED, COLOR-BLACK  
UL94V-0 FLAMMABILITY RATED.



RETENTION CLIP: COPPER ALLOY OR STAINLESS STEEL

1. PART NUMBER CHANGES AND OR DESIGN CHANGES AFFECTING ITEM INTERCHANGEABILITY REQUIRE PRIOR ELCON APPROVAL AND AUTHORIZATION BY REVISION TO THIS DRAWING.

NOTES: UNLESS OTHERWISE SPECIFIED

1648111-1      AS SHOWN

PART NUMBER      DESCRIPTION

INCH MM  THIRD ANGLE PROJECTION UNLESS OTHERWISE SPECIFIED DIMENSIONS ARE IN INCHES (METRIC) TOLERANCES ANGLES ± .5° DECIMALS .XXX ± .010 (.25) .XX ± .02 (.3)	DRAWN HA NGUYEN	DATE 03/04/06	 Tyco Electronics Corporation Menlo Park, Ca 94025 
	CHECKED		
	APPROVED		
	APPROVED STEVE FLICKINGER	03/04/06	
	DCA APPROVED HA NGUYEN	03/04/06	TITLE CONNECTOR, PIN HOUSING #16, #20, #16 CONFIGURATION MINI DRAWER
	ACAD FILE NUMBER C1648111A.DWG		SIZE DWG NUMBER B C = 1648111 REV. A
		DWG SCALE 1=1	SH 1 OF 3

4

3

2

1

This drawing involves proprietary design rights of Tyco Electronics Corporation, and all design, manufacture, reproduction, use and sale rights regarding the same are expressly reserved. It is submitted for a specific purpose and the recipient by accepting this drawing, assumes custody and control and agrees to take reasonable precautions: (a) that this drawing will not be copied and reproduced, in whole or in part, or its contents revealed in any manner, or to any person except to meet the purpose for which it was delivered and (b) that any special features peculiar to this design will not be incorporated in other projects without the expressed written permission of Tyco Electronics Corporation.

REVISIONS			
EC	REV	DESCRIPTION	DATE
		SEE SHEET 1	

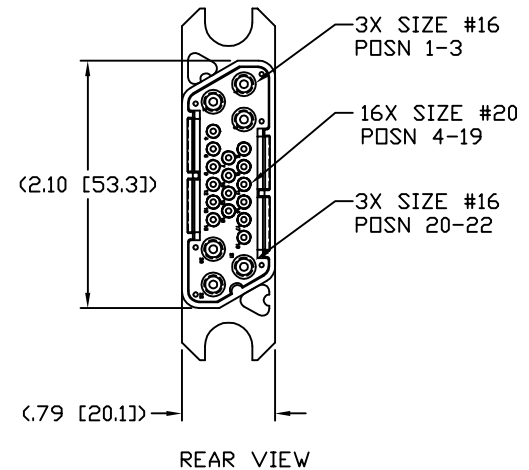
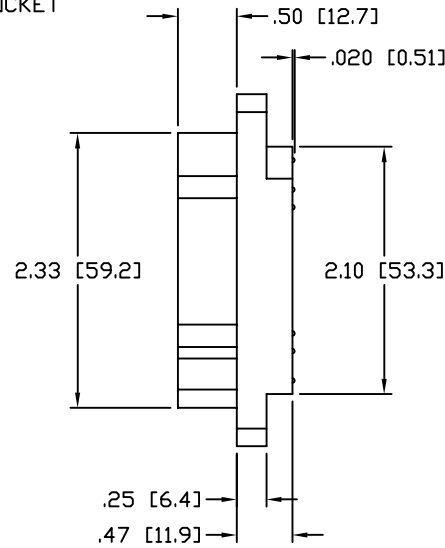
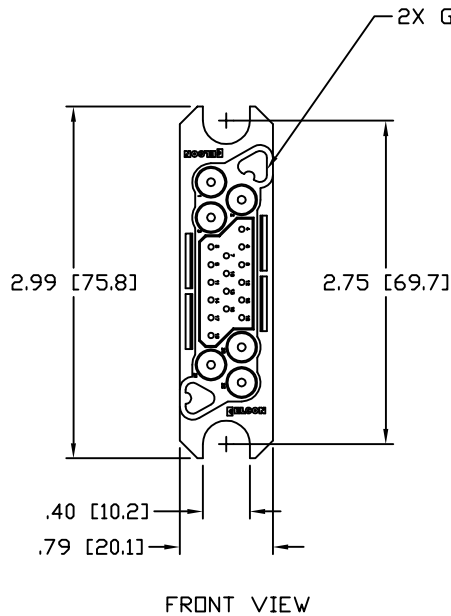

FRONT VIEW

REAR VIEW

INCH OR INCH (MM)  THIRD ANGLE PROJECTION UNLESS OTHERWISE SPECIFIED DIMENSIONS ARE IN INCHES (METRIC) TOLERANCES ANGLES ± .5° DECIMALS .XXX ± .010 (.25) .XX ± .02 (.3)	DRAWN HA NGUYEN	DATE 03/04/06	Tyco Electronics Corporation Menlo Park, Ca 94025 		
	CHECKED			TITLE CONNECTOR, PIN HOUSING #16, #20, #16 CONFIGURATION MINI DRAWER	
	APPROVED STEVE FLICKINGER	03/04/06		SIZE DWG NUMBER B C = 1648111	REV. A
	DCA APPROVED HA NGUYEN	03/04/06		ACAD FILE NUMBER C1648111A.DWG	DWG SCALE 1=1 SH 2 OF 3

This drawing involves proprietary design rights of Tyco Electronics Corporation, and all design, manufacture, reproduction, use and sale rights regarding the same are expressly reserved. It is submitted for a specific purpose and the recipient by accepting this drawing, assumes custody and control and agrees to take reasonable precautions: (a) that this drawing will not be copied and reproduced, in whole or in part, or its contents revealed in any manner, or to any person except to meet the purpose for which it was delivered and (b) that any special features peculiar to this design will not be incorporated in other projects without the expressed written permission of Tyco Electronics Corporation.

REVISIONS			
EC	REV	DESCRIPTION	DATE
		SEE SHEET 1	

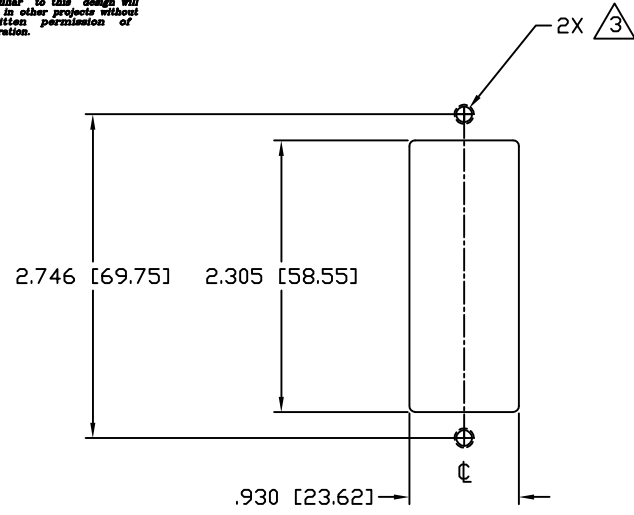

RECOMMENDED PANEL CUTOUT  
AS VIEWED FROM CONNECTOR MOUNTING SIDE  
(FRONT VIEW)

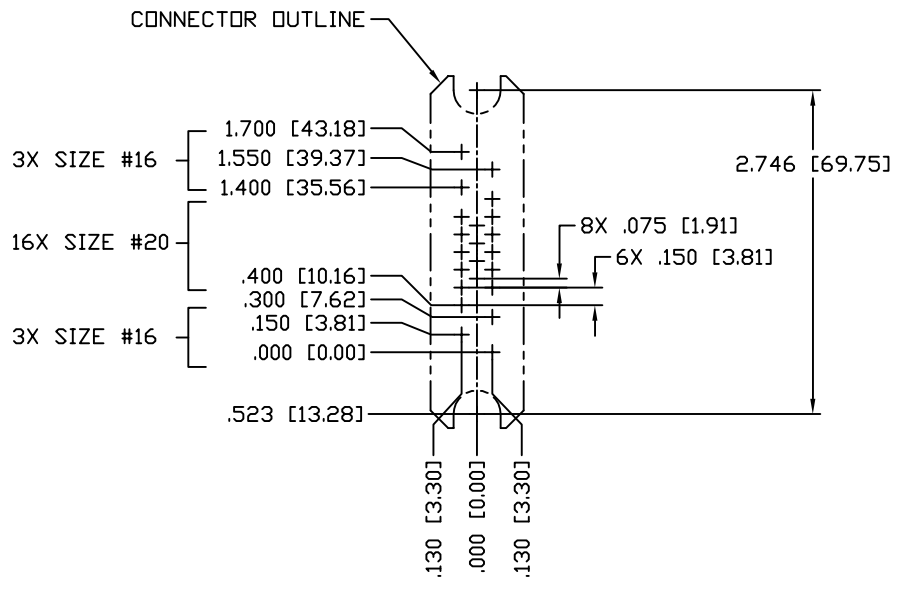

CONTACT LAYOUT  
AS VIEWED FROM CONNECTOR MOUNTING SIDE  
(FRONT VIEW)

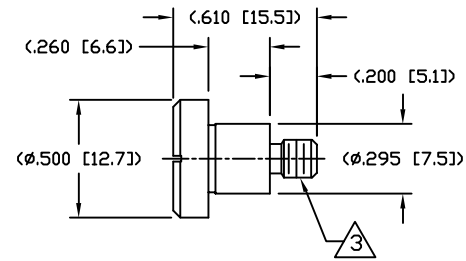

SHOULDER SCREW  
SCALE 2:1  
SHOWN FOR REFERENCE ONLY

INCH OR INCH (MM)  THIRD ANGLE PROJECTION UNLESS OTHERWISE SPECIFIED DIMENSIONS ARE IN INCHES (METRIC) TOLERANCES ANGLES ± .5° DECIMALS .XXX ± .010 (.25) .XX ± .02 (.3)	DRAWN HA NGUYEN	DATE 03/04/06	Tyco Electronics Corporation Menlo Park, Ca 94025 	
	CHECKED			TITLE USER INFORMATION RECOMMENDED PANEL CUTOUT AND CONTACT LAYOUT
	APPROVED		SIZE DWG NUMBER B C = 1648111	REV. A
	APPROVED STEVE FLICKINGER DCA APPROVED HA NGUYEN	03/04/06 03/04/06	ACAD FILE NUMBER C1648111A.DWG	DWG SCALE 1=1 SH 3 OF 3

## X-ON Electronics

Largest Supplier of Electrical and Electronic Components

*Click to view similar products for [Heavy Duty Power Connectors](#) category:*

*Click to view products by [TE Connectivity](#) manufacturer:*

Other Similar products are found below :

[647757-1](#) [6643411-1](#) [6646058-2](#) [6646137-1](#) [6646138-1](#) [6646479-1](#) [6646608-1](#) [6646786-1](#) [6646940-1](#) [6651091-1](#) [6651525-1](#) [6651529-1](#)  
[6651788-1](#) [696475-1](#) [702-32-01109](#) [703-25-02205](#) [73000005059](#) [73000005642](#) [73080255059](#) [73080965046](#) [765-15-0080A](#) [765-16-0080B](#)  
[765-18-0080D](#) [829992-1](#) [902-77-02113](#) [PS00/A0620/6300](#) [PS25/A0420/63](#) [129-1J](#) [1409400](#) [AN0024023](#) [E6374G1](#) [e6389g2](#) [157-43GW8](#)  
[MS3117-14AC](#) [1643543-1](#) [1650540-1](#) [1651811-2](#) [1766260-1](#) [1766282-1](#) [1766966-1](#) [1791340000](#) [NLDFT-3-BL-L-S120-M40A](#) [NLDFT-N-](#)  
[W-L-C240-M40B](#) [NLS-2-R-C240-M40B](#) [NLS-N-W-C240-M40B](#) [NPS-3-BL-T6](#) [1986615-1](#) [2-1589900-8](#) [2199314-1](#) [KA8102](#)