

THIS DRAWING IS UNPUBLISHED. RELEASED FOR PUBLICATION
 © COPYRIGHT - By - ALL RIGHTS RESERVED.

REVISIONS					
P	LTR	DESCRIPTION	DATE	DWN	APVD
AE		REVISED PER ECO-12-012316	05JUL12	KH	MZ
AF		REVISED PER ECO-16-017885	06OCT2017	RS	MZ

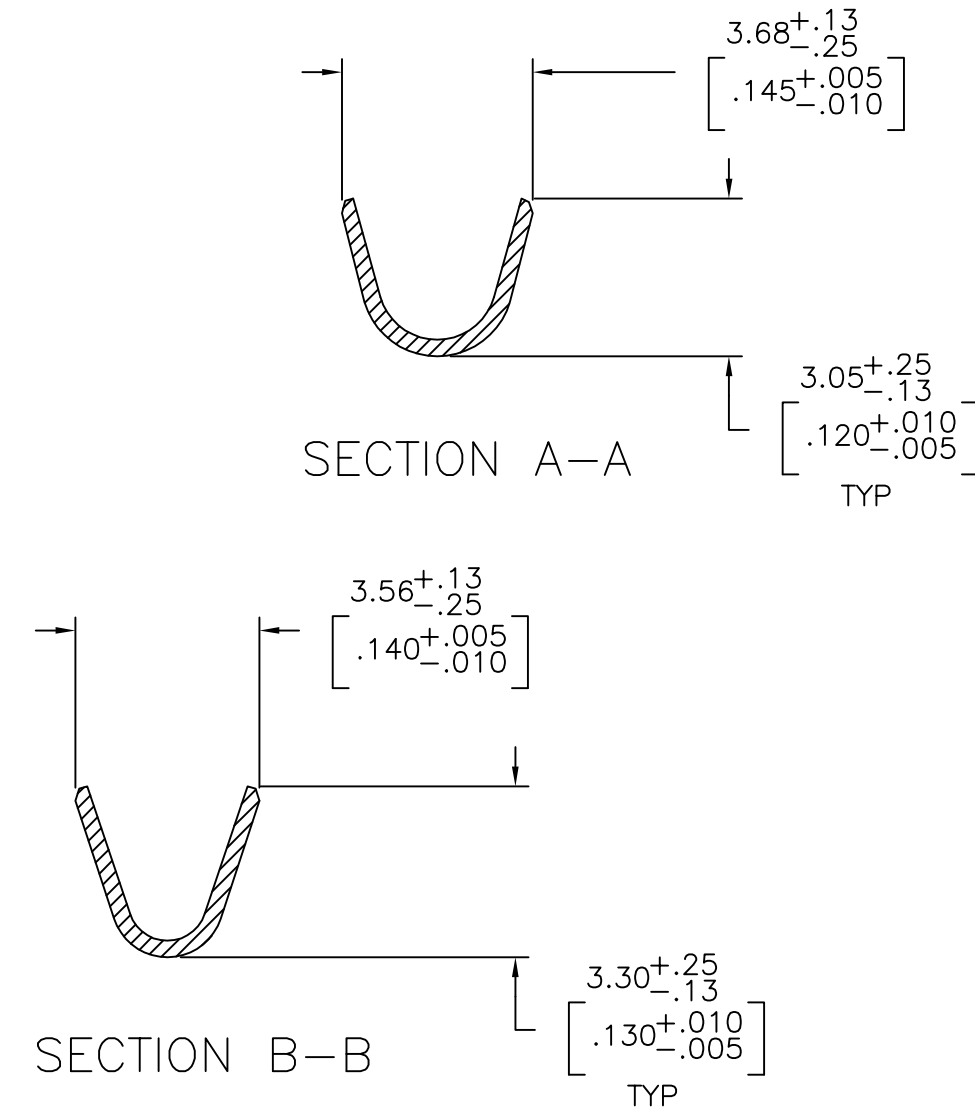
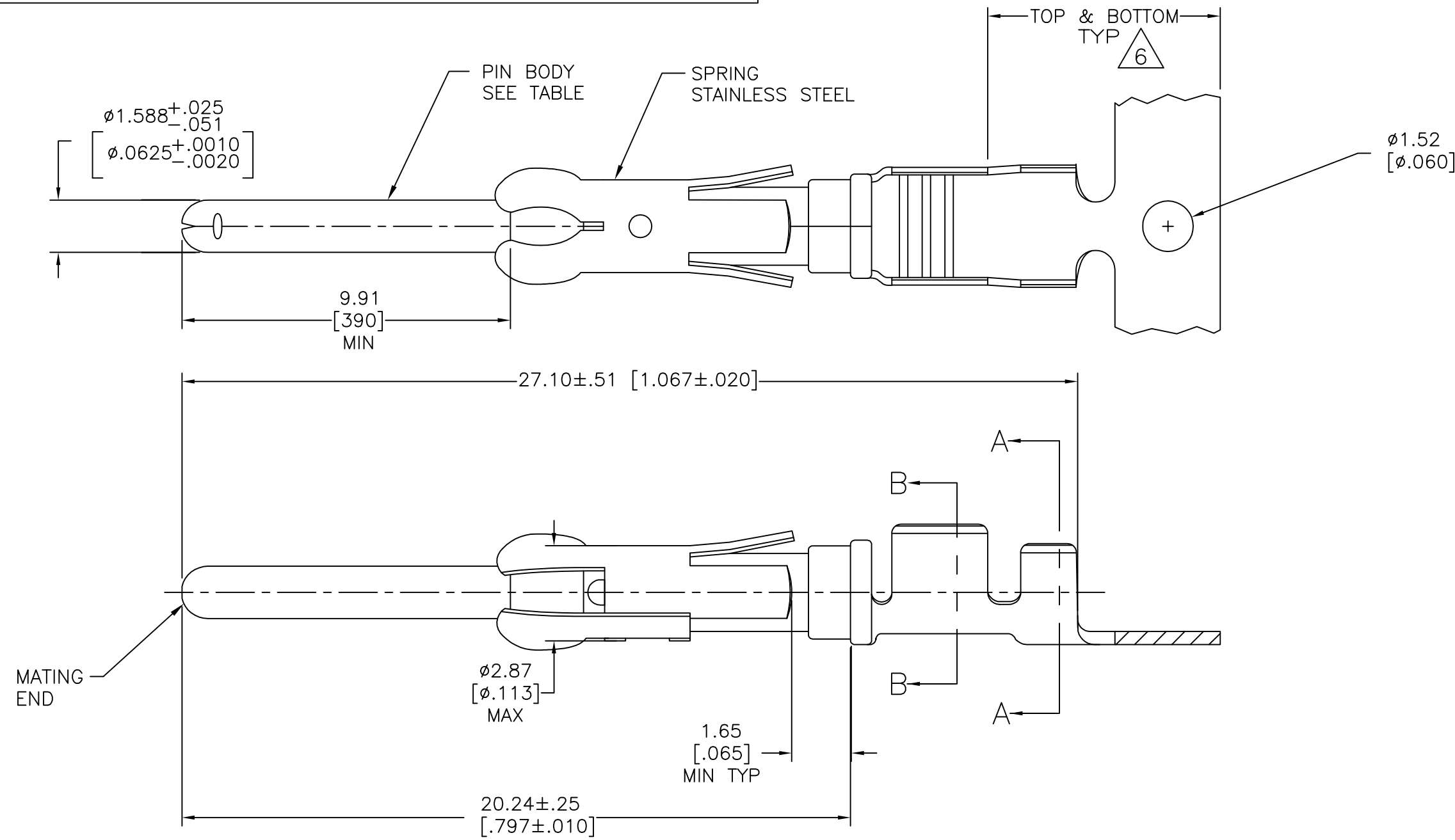

- 1 REVERSE REELED FOR MINI-APPLICATOR.
- 2 $0.76\mu\text{m}$ [.000030] MIN PRECIOUS METAL PLATE ON MATING END FOR A LENGTH OF 5.08 [.200] MIN OVER $1.27\mu\text{m}$ [.000050] MIN NICKEL. GOLD FLASH ALL OVER. CONFORMS TO THE REQUIREMENTS OF TE CONNECTIVITY PRODUCT SPEC 108-10042, BASED ON EIA/ECA-364-1000.01 (CONTROLLED ENVIRONMENT APPLICATIONS),
- 3 $0.76\mu\text{m}$ [.000030] MIN PRECIOUS METAL PLATE ON MATING END FOR A LENGTH OF 5.08 [.200] MIN WITH A UNIFORM GRADIENT TO $0.25\mu\text{m}$ [.000010] MIN ON REMAINDER, OVER $1.27\mu\text{m}$ [.000050] MIN NICKEL PLATE. GOLD FLASH ALL OVER. CONFORMS TO THE REQUIREMENTS OF TE CONNECTIVITY PRODUCT SPEC 108-10042, BASED ON EIA/ECA-364-1000.01 (CONTROLLED ENVIRONMENT APPLICATIONS).
- 4 $0.38\mu\text{m}$ [.000015] MIN GOLD PER MIL-G-45204 ON MATING END FOR A LENGTH OF 5.08 [.200] MIN WITH $1.27\mu\text{m}$ [.000050] MATTE TIN PLATE IN WIRE CRIMP AREA, BOTH OVER $1.27\mu\text{m}$ [.000050] MIN NICKEL PER QQ-N-290.
- 5 $1.27\mu\text{m}$ [.000050] MIN TIN-LEAD PER MIL-T-10727 OVER $1.27\mu\text{m}$ [.000050] MIN NICKEL PER QQ-N-290.
- 6 GOLD PLATING NEED NOT APPEAR IN THIS AREA.
- 7 WIRE RANGE 18-14 AWG.
- 8 INSULATION RANGE 2.03[.080]-2.54[.100] DIA.
- 9 $0.38\mu\text{m}$ [.000015] MIN GOLD PER MIL-G-45204 ON MATING END FOR A LENGTH OF 5.08 [.200] MIN, $1.27\mu\text{m}$ [.000050] MIN TIN-LEAD PER MIL-T-10727 FOR A LENGTH OF 5.69 [.224] MIN ON OPPOSITE END, BOTH OVER $1.27\mu\text{m}$ [.000050] MIN NICKEL PER QQ-N-290 ON ENTIRE CONTACT.
- 10 $1.27\mu\text{m}$ [.000050] MIN TIN PER MIL-T-10727 OVER $1.27\mu\text{m}$ [.000050] MIN NICKEL PER QQ-N-290.
- 11 $2.54\mu\text{m}$ [.000100] MIN SILVER OVER $0.76\mu\text{m}$ [.000030] MIN NICKEL PER QQ-N-290
- 12 $0.76\mu\text{m}$ [.000030] MIN PRECIOUS METAL PLATE ON MATING END FOR A LENGTH OF 5.08 [.200] MIN WITH $1.27\mu\text{m}$ [.000050] MATTE TIN PLATE IN WIRE CRIMP AREA, BOTH OVER $1.27\mu\text{m}$ [.000050] NICKEL PLATE. CONFORMS TO THE REQUIREMENTS OF TE CONNECTIVITY PRODUCT SPEC 108-10042, BASED ON EIA/ECA-364-1000.01A (CONTROLLED ENVIRONMENT APPLICATIONS).

OBSOLETE	1	11	BRASS	-	2-66359-0
	1	10	CU-NI ALLOY	1-66361-6	1-66359-9
	STANDARD	10	BRASS	1-66361-2	1-66359-8
	1	5	CU-NI ALLOY	1-66361-5	1-66359-7
	1	2	CU-NI ALLOY	1-66361-4	1-66359-6
	1	10	PHOSPHOR BRONZE	-	1-66359-5
	1	10	BRASS	1-66361-2	1-66359-4
OBSOLETE	1	9	BRASS	66361-9	1-66359-3
	1	2	PHOSPHOR BRONZE	66361-8	1-66359-2
	1	5	PHOSPHOR BRONZE	66361-7	1-66359-1
	1	12	BRASS	66361-4	1-66359-0
	1	4	BRASS	66361-3	66359-9
	1	5	BRASS	66361-2	66359-6
	1	3	BRASS	66361-1	66359-5
	STANDARD	12	BRASS	66361-4	66359-4
	STANDARD	4	BRASS	66361-3	66359-3
	STANDARD	5	BRASS	66361-2	66359-2
	STANDARD	3	BRASS	66361-1	66359-1
	REELING	PIN BODY FINISH	PIN BODY	LOOSE PIECE REF	PART NO

THIS DRAWING IS A CONTROLLED DOCUMENT. DWN V. FURLER 23JUL2003
 CHK G. STEINHAUER 24JUL03
 APVD G. STEINHAUER 24JUL03

DIMENSIONS: mm [INCHES] TOLERANCES UNLESS OTHERWISE SPECIFIED:
 0 PLC ± -
 1 PLC ± -
 2 PLC ± 0.13 [.005]
 3 PLC ± -
 4 PLC ± -
 ANGLES ± -
 FINISH SEE TABLE

NAME: G. STEINHAUER
 PRODUCT SPEC: -
 APPLICATION SPEC: -
 WEIGHT: -

TE Connectivity
 PIN ASSEMBLY, .062, TYPE III+

SIZE: A2 CAGE CODE: 00779 DRAWING NO: C=66359 RESTRICTED TO: -
 CUSTOMER DRAWING SCALE: NTS SHEET: 1 of 1 REV: AF

X-ON Electronics

Largest Supplier of Electrical and Electronic Components

Click to view similar products for [Standard Circular Contacts](#) category:

Click to view products by [TE Connectivity](#) manufacturer:

Other Similar products are found below :

[RC16M23J](#) [133780-1](#) [RM20M13D28](#) [RM24M9D28](#) [RMMX110-1D28](#) [ELFH02211](#) [ELVP16100E](#) [164-901-CD](#) [BACS16X1A](#)
[EN3545007SCE](#) [BV002BSQ20049CZ](#) [BV002SSQ160404CZ](#) [1900ND05S1B00B](#) [SJS862201](#) [166566-1](#) [1900ND04S1X00D](#) [ST-JL05-16S-](#)
[C3-100](#) [ST-JL05-20S-C1-100](#) [ST-JL05-20S-C2-100](#) [T01-CRIMP-S03](#) [APK-SA16A07-002](#) [27963-15T12](#) [CONT-JL05-08S-C2-10](#) [CONT-](#)
[JL05-12S-C1-10](#) [RC16M-23T](#) [RFD26L-1D28](#) [BV002ASJ16049CW](#) [33505815019](#) [JN1-22-20S-R-PKG100](#) [031-50213](#) [031-50794](#)
[ELFH08251](#) [ELFP0641GE](#) [SJS861301M](#) [ST-JL05-16S-C1-100](#) [ST-JL05-20P-C1-100](#) [82911466K](#) [82911467NK](#) [ESLM03200](#) [192991-0087](#)
[192900-0570](#) [T3P16FC3LZ](#) [ST-JL05-16S-C2-3500](#) [ZP-4016-10NF](#) [CONT-JL05-12P-C1-10](#) [RM20M12G8D28](#) [031-50676](#) [12115010110](#)
[RJFTVC2MG](#) [CAP-DACMDPC2](#)