

THIS DRAWING IS UNPUBLISHED. RELEASED FOR PUBLICATION
 © COPYRIGHT - By - ALL RIGHTS RESERVED.

REVISIONS					
P	LTR	DESCRIPTION	DATE	DWN	APVD
J1		REVISED PER ECO-14-001124	24JAN2014	NK	MZ
J2		REVISED PER ECO-18-006394	27APR2018	RS	MZ

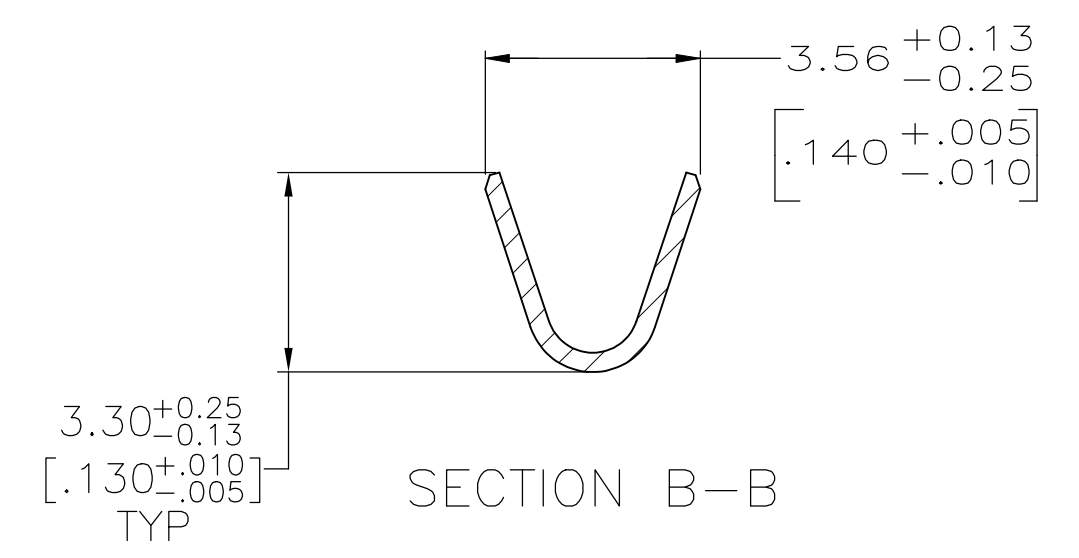
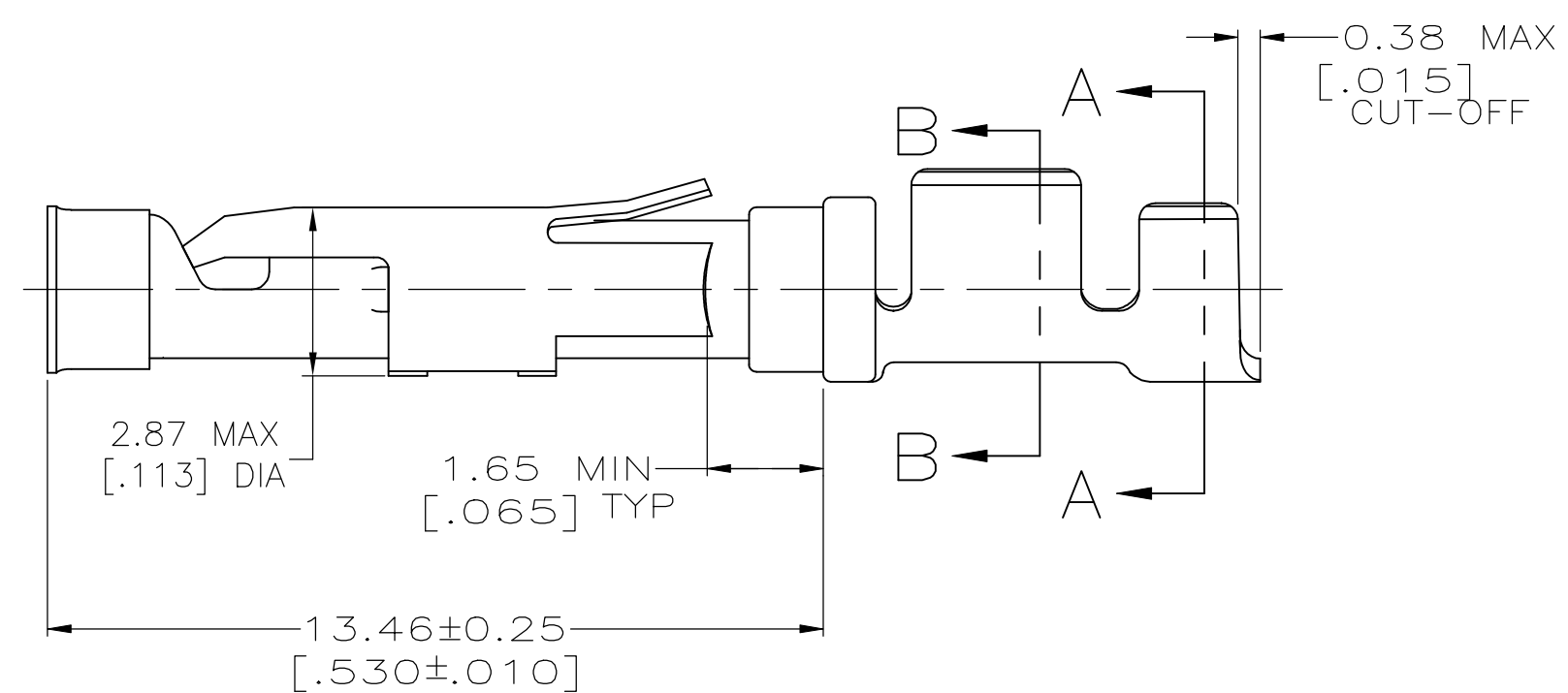
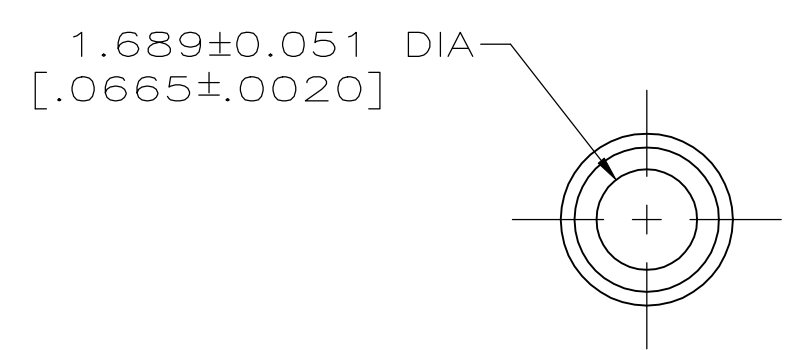
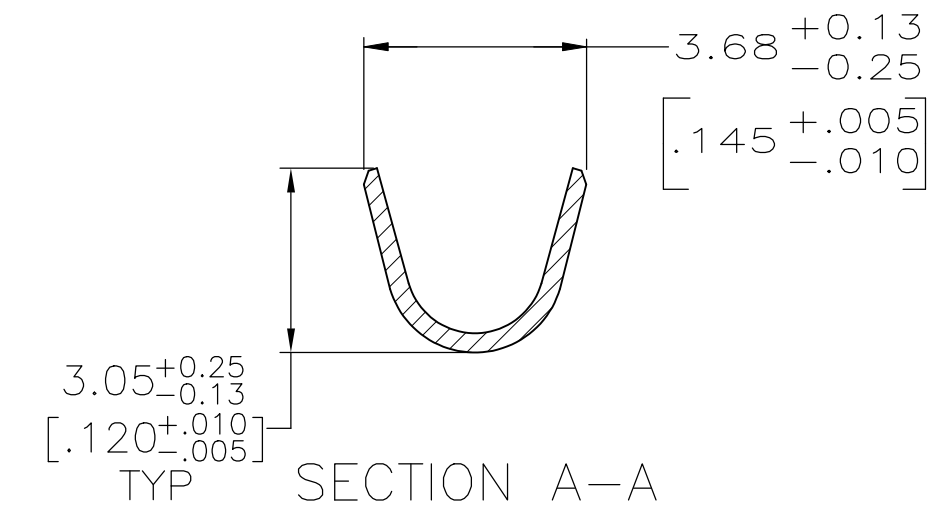
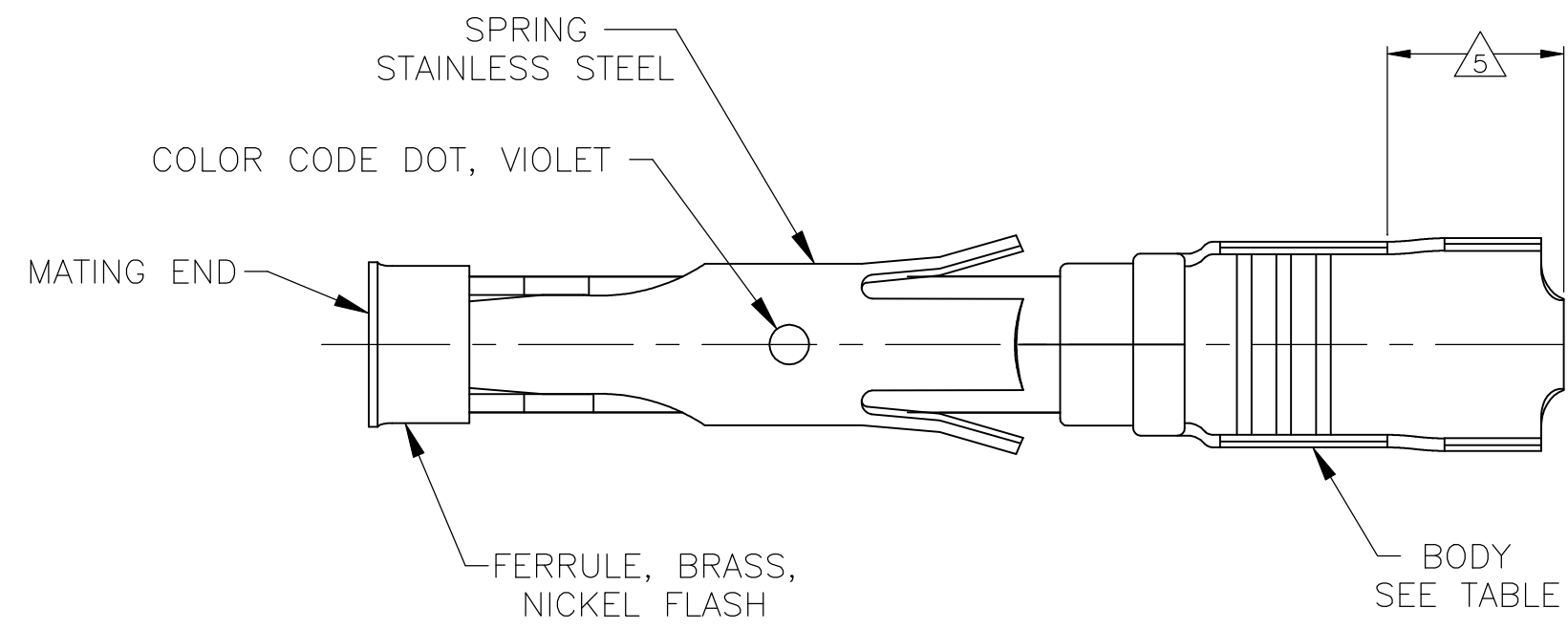

- 1 0.76µm [.000030] MIN GOLD PER MIL-G-45204 ON MATING END FOR A LENGTH OF 5.08 [.200] MIN WITH GOLD FLASH ON THE REMAINDER OVER 0.76µm [.000030] MIN NICKEL PER QQ-N-290.
- 2 1.27µm [.000050] MIN TIN-LEAD PER MIL-T-10727 OVER 0.76µm [.000030] MIN NICKEL PER QQ-N-290.
- 3 0.76µm [.000030] MIN GOLD PER MIL-G-45204 ON MATING END FOR A LENGTH OF 5.08 [.200] MIN WITH A UNIFORM GRADIENT TO 0.25µm [.000010] MIN GOLD PER MIL-G-45204 ON THE REMAINDER OVER 0.76µm [.000030] MIN NICKEL PER QQ-N-290.
- 4 0.38µm [.000015] MIN GOLD PER MIL-G-45204 ON MATING END FOR A LENGTH OF 5.08 [.200] MIN WITH 1.27µm [.000050] MIN MATTE TIN PLATE IN WIRE CRIMP AREA, BOTH OVER 0.76µm [.000030] MIN NICKEL PER QQ-N-290.
- 5 GOLD PLATING NOT REQUIRED IN THIS AREA.
- 6 WIRE RANGE 18-14 AWG. INSULATION RANGE 2.03[.080]-2.54[.100].
- 7 0.38µm [.000015] MIN GOLD PER MIL-G-45204 ON MATING END FOR A LENGTH OF 5.08 [.200] MIN, 1.27µm [.000050] MIN TIN-LEAD PER MIL-T-10727 FOR A LENGTH OF 5.69 [.224] MIN ON OPPOSITE END, BOTH OVER 1.27µm [.000050] MIN NICKEL PER QQ-N-290 ON ENTIRE CONTACT.
- 8 1.27µm [.000050] MIN TIN PER MIL-T-10727 OVER 0.76µm [.000030] MIN NICKEL PER QQ-N-290.
- 9 0.76µm [.000030] MIN GOLD PER MIL-G-45204 ON MATING END FOR A LENGTH OF 5.08[.200]MIN WITH 1.27µm [.000050] MIN MATTE TIN PLATE IN WIRE CRIMP AREA, BOTH OVER 0.76µm [.000050] MIN NICKEL PER QQ-N-290.

STANDARD	8	CU-NI ALLOY	2-66358-1	1-66360-6	
STANDARD	2	CU-NI ALLOY	2-66358-0	1-66360-5	
STANDARD	1	CU-NI ALLOY	1-66358-9	1-66360-4	
SMALL PACK	8	BRASS	1-66358-6 OR 1-66358-7	1-66360-3	
STANDARD	8	BRASS	1-66358-6 OR 1-66358-7	1-66360-2	
SMALL PACK	9	BRASS	66358-4	1-66360-1	
SMALL PACK	2	BRASS	66358-2	1-66360-0	
OBSOLETE	STANDARD	7	BRASS	1-66358-5	66360-9
STANDARD	1	PHOSPHOR BRONZE	1-66358-3	66360-8	
OBSOLETE	STANDARD	2	PHOSPHOR BRONZE	1-66358-2	66360-7
STANDARD	9	BRASS	66358-4	66360-4	
STANDARD	4	BRASS	66358-3	66360-3	
STANDARD	2	BRASS	66358-2	66360-2	
STANDARD	3	BRASS	66358-1	66360-1	
PACKAGING	BODY FINISH	BODY MATERIAL	STRIP P/N REF	PART NUMBER	

THIS DRAWING IS A CONTROLLED DOCUMENT. DWN L.SIPE 06/03/92
 CHK W.LENKER 6-11-92
 APVD G.STEINHAUER 7-8-92
 PRODUCT SPEC
 APPLICATION SPEC

STE TE Connectivity Ltd.
 SOCKET ASSEMBLY, LOOSE PIECE, TYPE III+

SIZE A2 CAGE CODE 00779 DRAWING NO. C=66360 RESTRICTED TO -
 MATERIAL SEE CALLOUTS FINISH SEE TABLE WEIGHT CUSTOMER DRAWING SCALE 8:1 SHEET 1 of 1 REV J2

X-ON Electronics

Largest Supplier of Electrical and Electronic Components

Click to view similar products for [Standard Circular Contacts](#) category:

Click to view products by [TE Connectivity](#) manufacturer:

Other Similar products are found below :

[RC16M23J](#) [133780-1](#) [RM20M13D28](#) [RM24M9D28](#) [RMMX110-1D28](#) [MS3474W10-6P L/C](#) [ELVP16100E](#) [164-901-CD](#) [EN3545007SCE](#)
[BV002BSQ20049CZ](#) [BV002SSQ160404CZ](#) [1900ND05S1B00B](#) [SJS862201](#) [166566-1](#) [1900ND04S1X00D](#) [ST-JL05-16S-C3-100](#) [ST-JL05-20S-C1-100](#) [ST-JL05-20S-C2-100](#) [T01-CRIMP-S03](#) [APK-SA16A07-002](#) [27963-15T12](#) [CONT-JL05-08S-C2-10](#) [CONT-JL05-12S-C1-10](#)
[RC16M-23T](#) [RFD26L-1D28](#) [BV002ASJ16049CW](#) [JN1-22-20S-R-PKG100](#) [031-50213](#) [031-50565](#) [031-50794](#) [SJS861301M](#) [ST-JL05-16S-C1-100](#) [ST-JL05-20P-C1-100](#) [82911466K](#) [82911467NK](#) [192991-0087](#) [192900-0570](#) [T3P16FC3LZ](#) [ST-JL05-16S-C2-3500](#) [ZP-4016-10NF](#)
[CONT-JL05-12P-C1-10](#) [RM20M12G8D28](#) [031-50676](#) [12115010110](#) [RJFTVC2MG](#) [CAP-DACMDPC2](#) [031-50675-002](#) [CAP-DD1FDPC2](#)
[CAP-DACMDPC1](#) [031-50966-010](#)