

REVISIONS				
P	LTN	DESCRIPTION	DATE	APVD
D15		REVISED PER ECO-20-004256	25MAR2020	JM DS
D16		REVISED PER PCN E-20-016603	24NOV2020	PN DS
E		REVISED PER ECN-21-123056	08NOV2021	DK CB

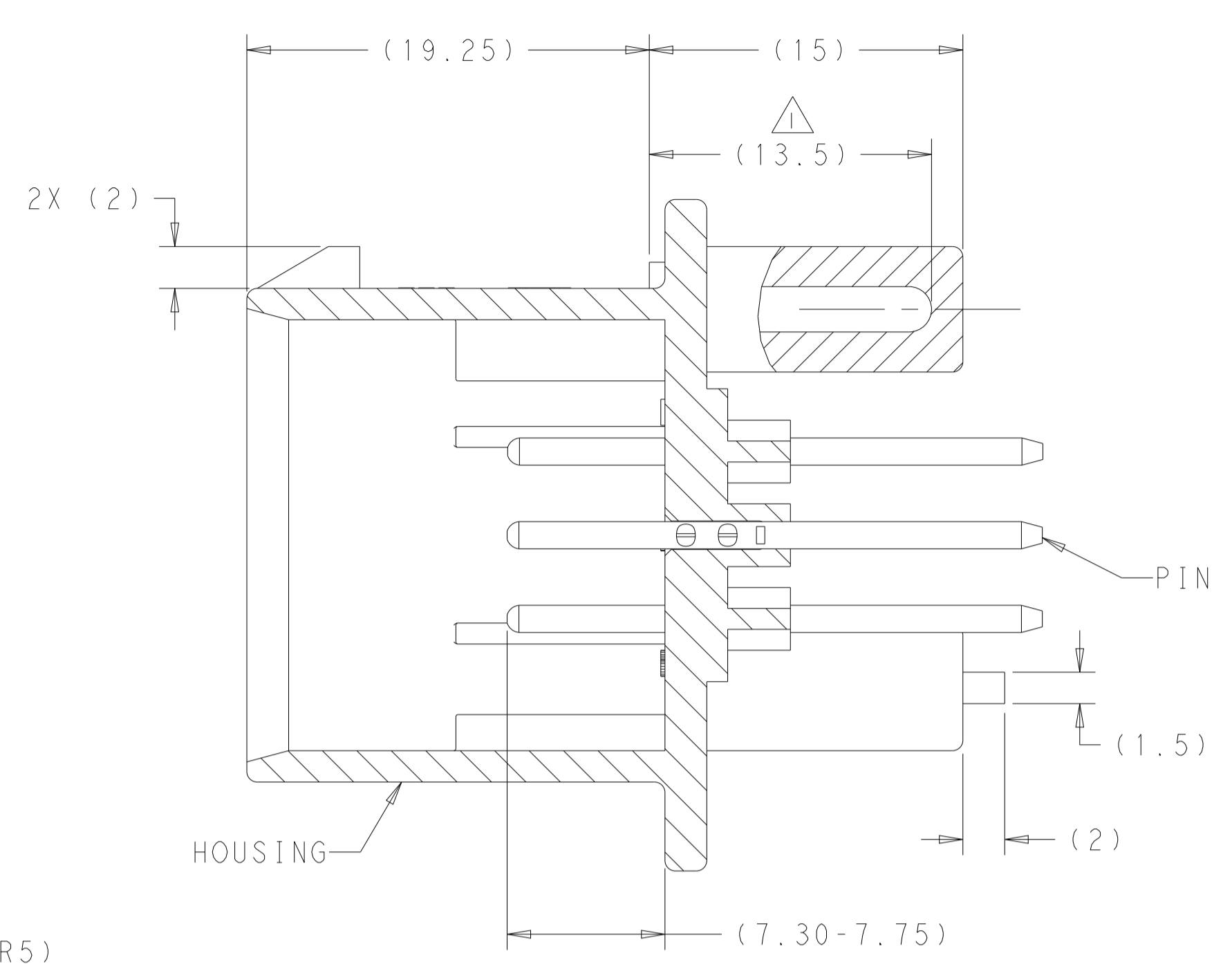

SECTION A-A

- 1 SUGGESTED MOUNTING SCREW SIZE IS $\varnothing 2.50-3.00\text{mm}$ [$\varnothing 0.099 - 0.118$ INCH] SELF TAPPING THREAD FORMING SCREW, SUCH AS DELTA PT, TO BE DRIVEN AT 0.6-0.8 N-m. THE CUSTOMER SHOULD TEST THE SCREW SIZE AND TYPE IN ORDER TO VERIFY THEIR SELECTION FOR THEIR APPLICATION.
- 2 DATE CODE IN THIS LOCATION USING 5 DIGIT CODE. FIRST 2 DIGITS = YEAR, SECOND 2 DIGITS = WEEK, LAST DIGIT = DAY.
- 3 MATERIALS: HEADER HOUSING - GLASS FILLED PBT; PINS - TIN OR GOLD PLATED BRASS.
- 4 HOUSING COLORS ARE MECHANICALLY KEYS TO MATE ONLY WITH IDENTICALLY COLORED PLUG ASSEMBLIES.
- 5. HEADER MATES TO PLUG ASSEMBLY 770680 WHICH USES REELED TERMINAL 770520 OR LOOSE PIECE TERMINAL 770854.

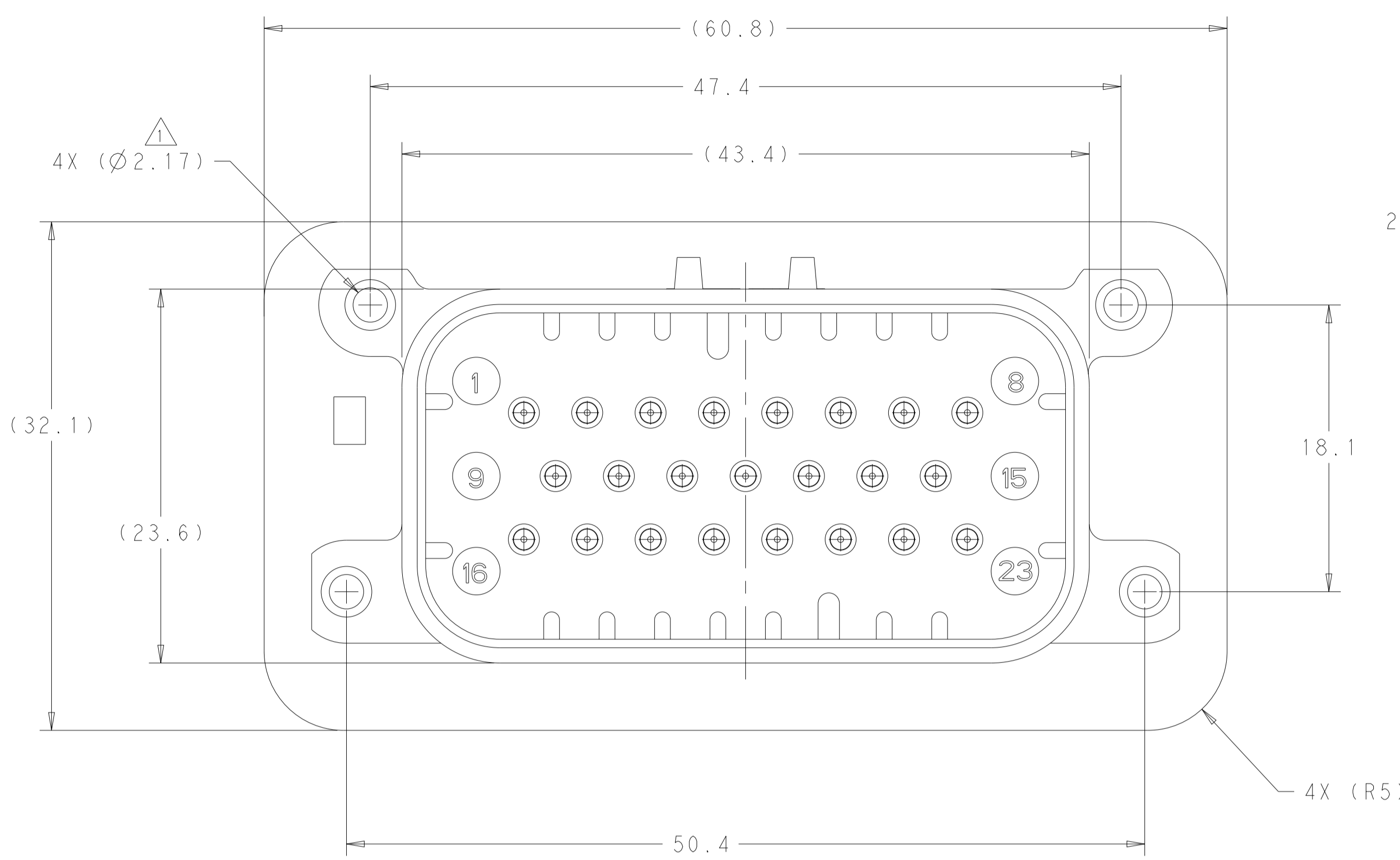
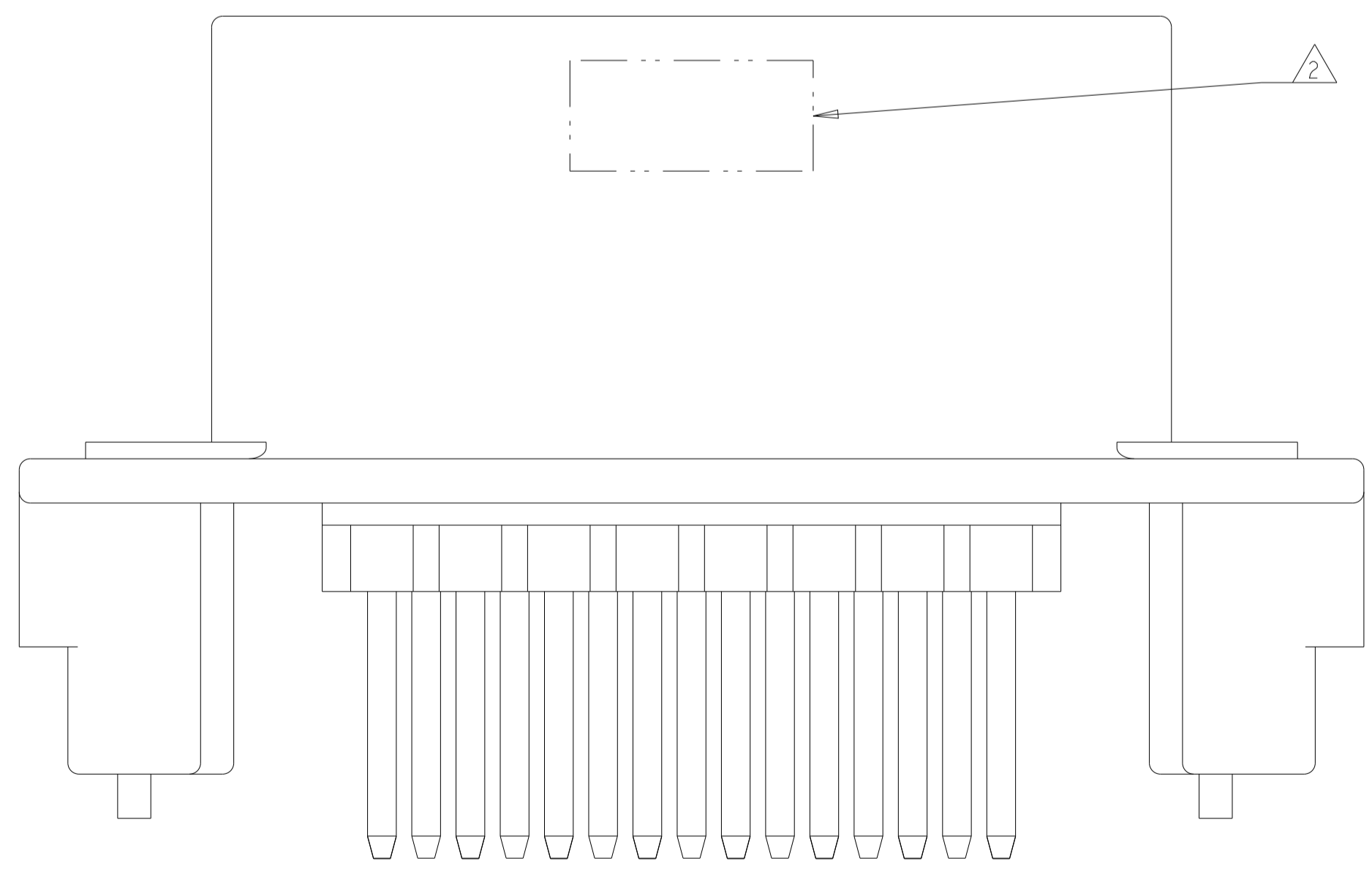

776200-1 & 1-776200-1 SHOWN

HEADER COLOR	PLATING	PART NUMBER
BLUE	GOLD	1-776200-5
GRAY	GOLD	1-776200-4
NATURAL	GOLD	1-776200-2
BLACK	GOLD	1-776200-1
BLUE	TIN	776200-5
GRAY	TIN	776200-4
NATURAL	TIN	776200-2
BLACK	TIN	776200-1

THIS DRAWING IS A CONTROLLED DOCUMENT.

DIMENSIONS:	TOLERANCES UNLESS OTHERWISE SPECIFIED:	OWN: D. STRAUSSER 04FEB2010	CHK: D. STRAUSSER 22MAR2010	APVD: D. STRAUSSER 27APR2010
mm	0 PLC ±0.2	NAME: D. STRAUSSER		
	1 PLC ±0.2	PRODUCT SPEC: 108-1329		
	2 PLC ±0.2	APPLICATION SPEC: 114-16016		
	3 PLC ±0.2	SIZE: A1	CAGE CODE: 00779	DRAWING NO: 776200
	4 PLC ±0.2	WEIGHT: 22.48g	SCALE: 4:1	SHEET 1 OF 2
ANGLES	FINISH	CUSTOMER DRAWING		

RESTRICTED TO: -

TE Connectivity

HEADER ASSEMBLY, 23 POSITION, VERTICAL, AMPSEAL

REVISIONS				
P	LTN	DESCRIPTION	DATE	APVD
-	-	SEE SHEET 1	-	-

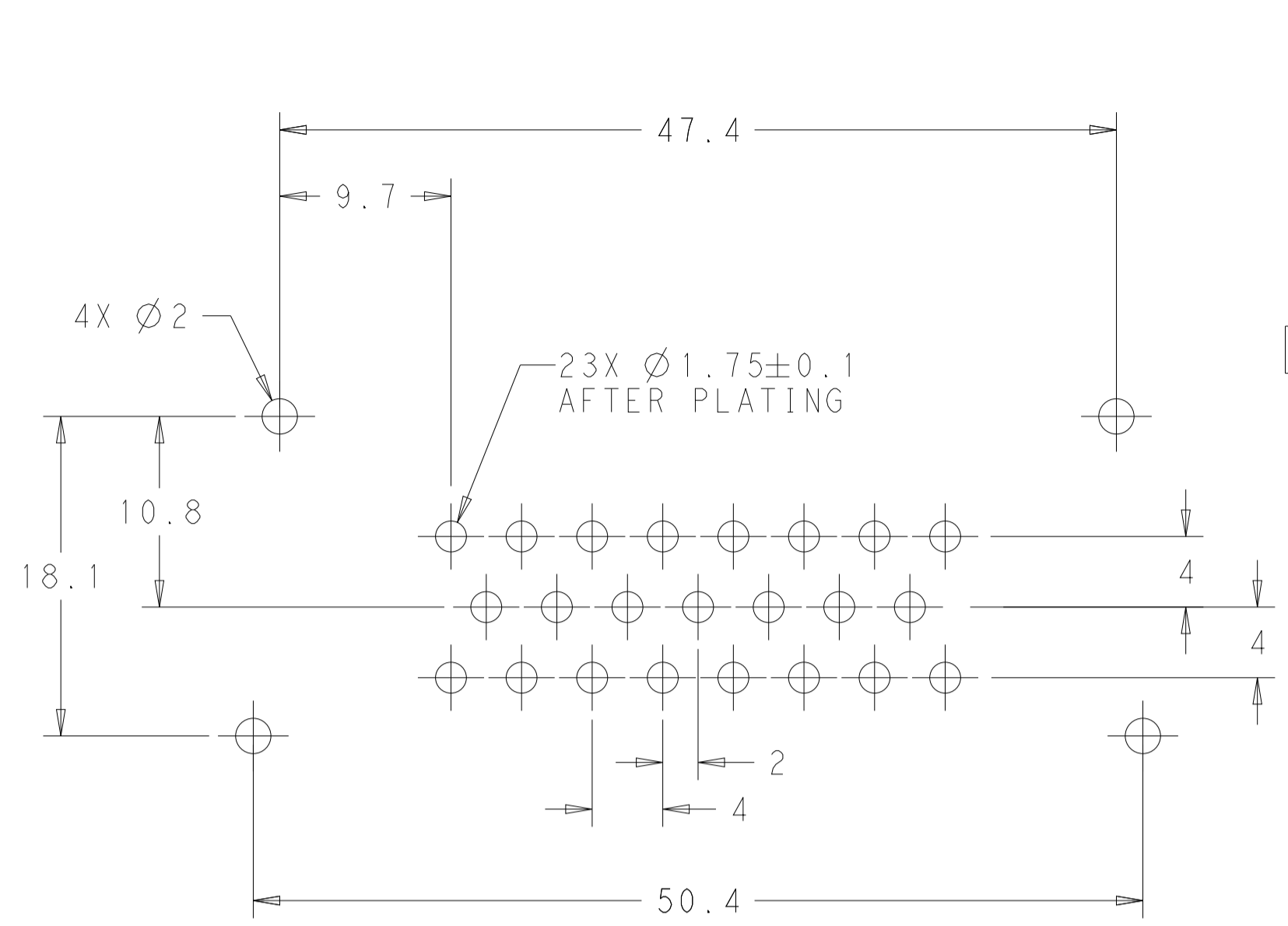

RECOMMENDED P.C. BOARD LAYOUT FOR 1.57 THICK P.C. BOARD

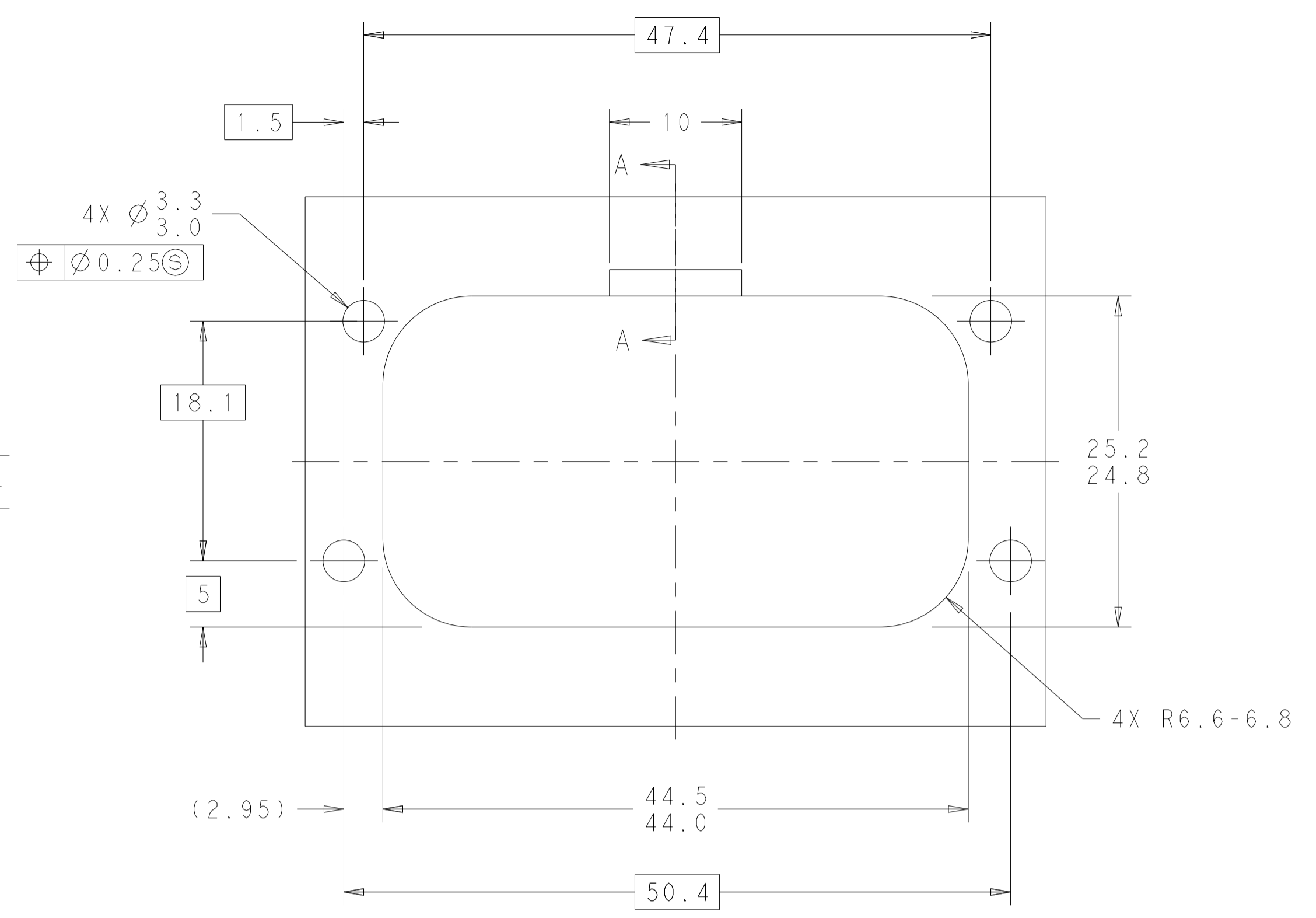

RECOMMENDED MOUNTING HOLE LAYOUT FOR 5.0 MAX THICK PANEL

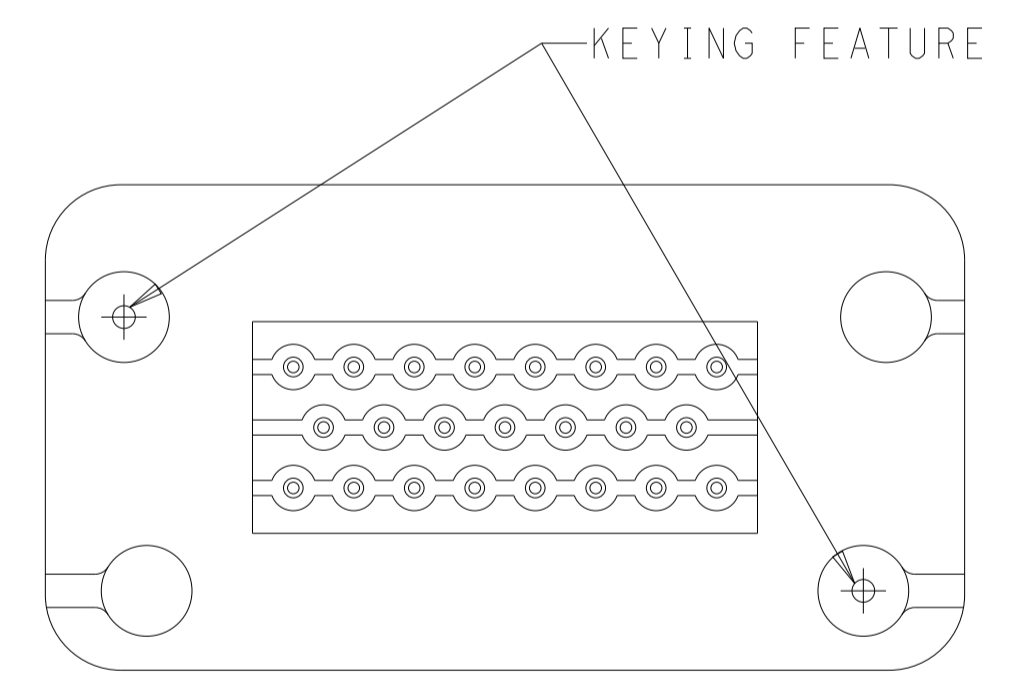
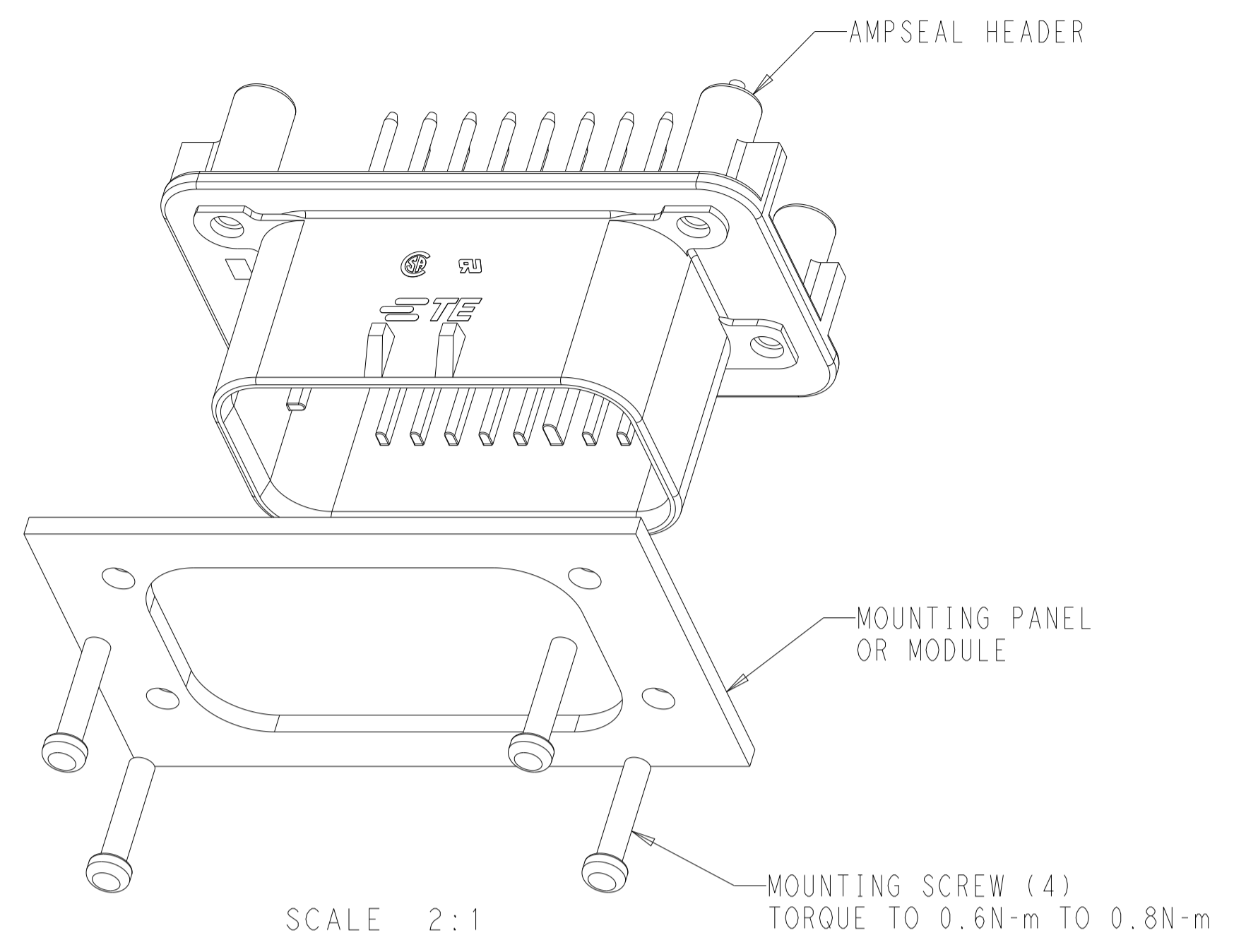

KEYING FOR 776200-1 AND 776200-5 SCALE 2:1

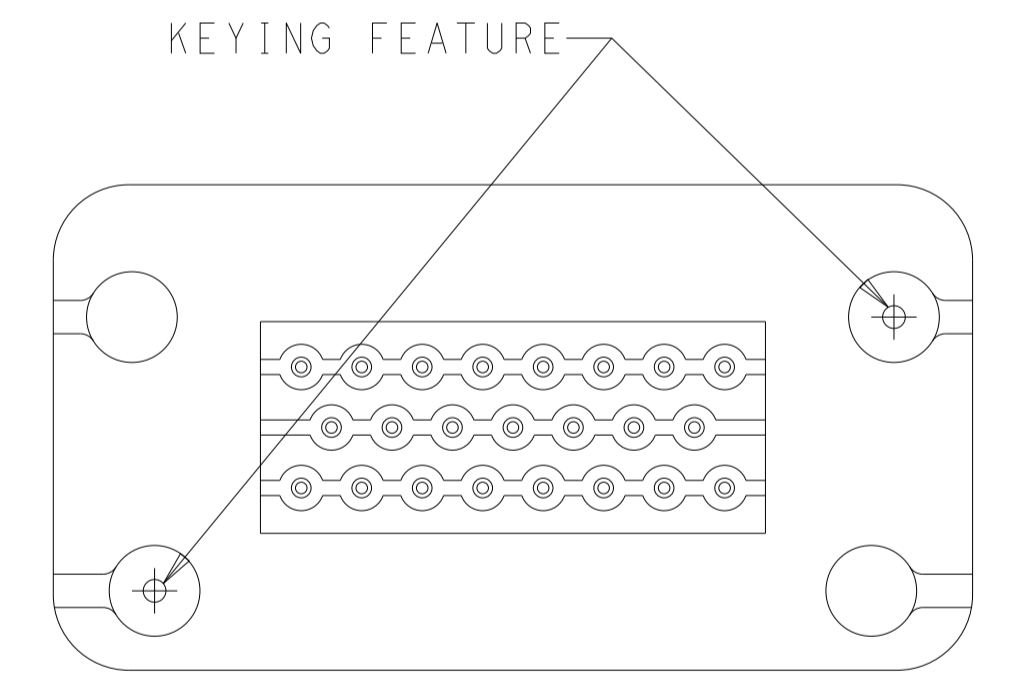

KEYING FOR 776200-2 AND 776200-4 SCALE 2:1

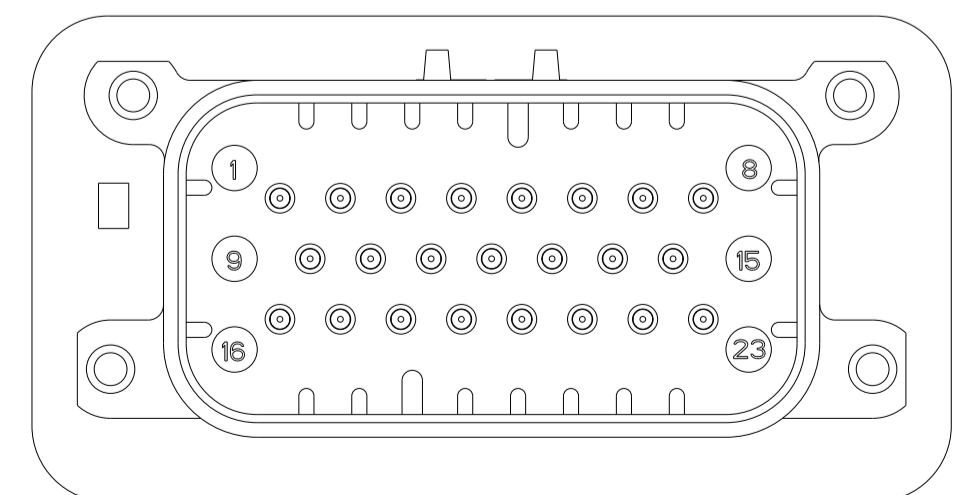

776200-2 & 1-776200-2 KEY LOCATION SCALE 2:1

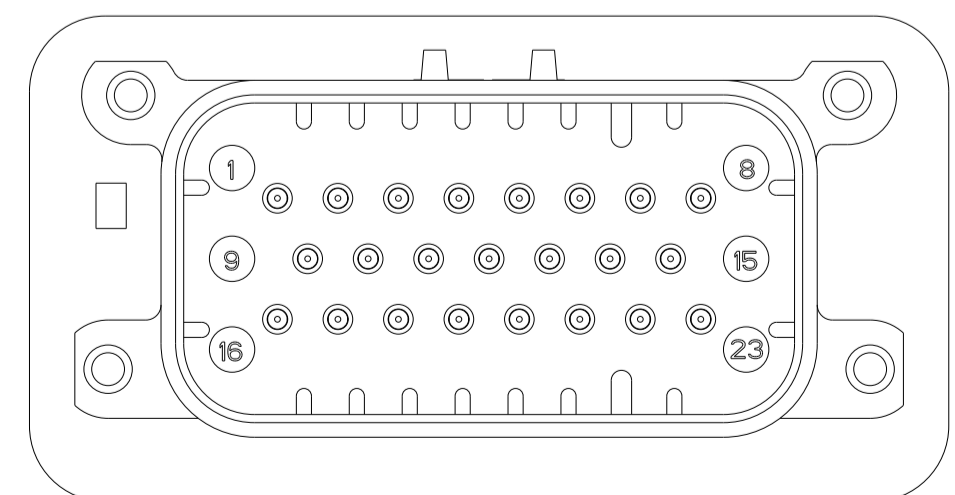

776200-4 & 1-776200-4 KEY LOCATION SCALE 2:1

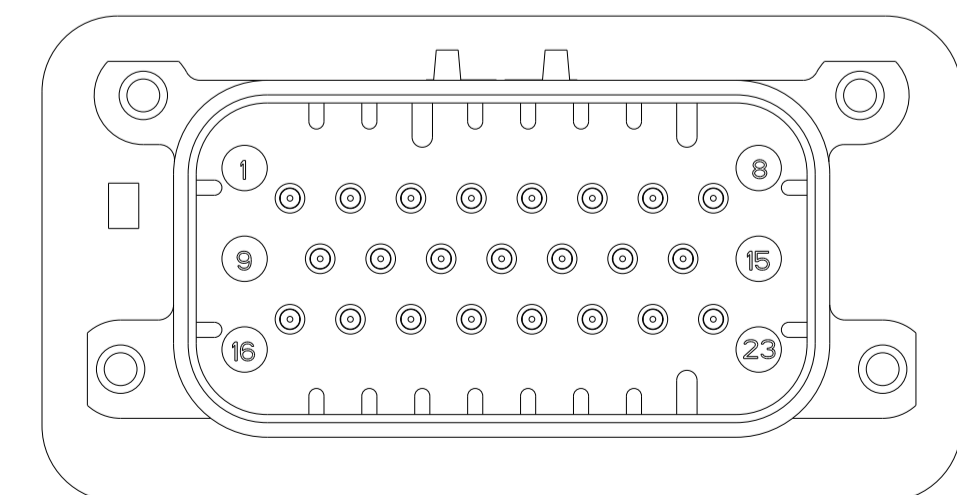

776200-5 & 1-776200-5 KEY LOCATION SCALE 2:1

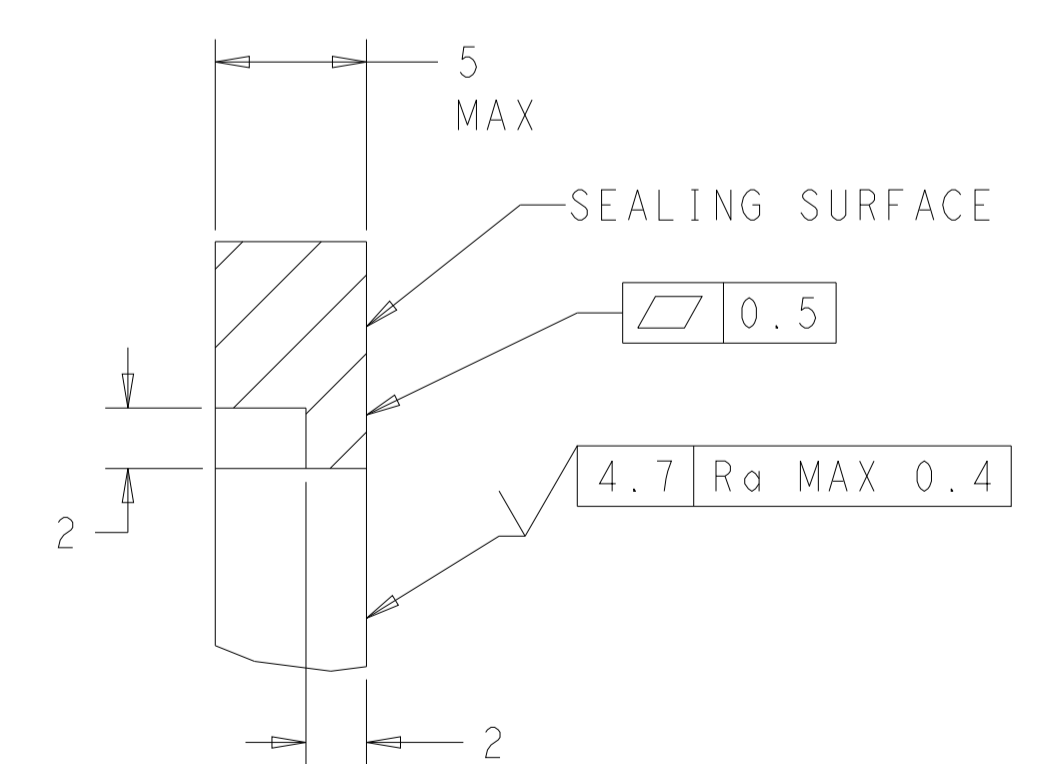
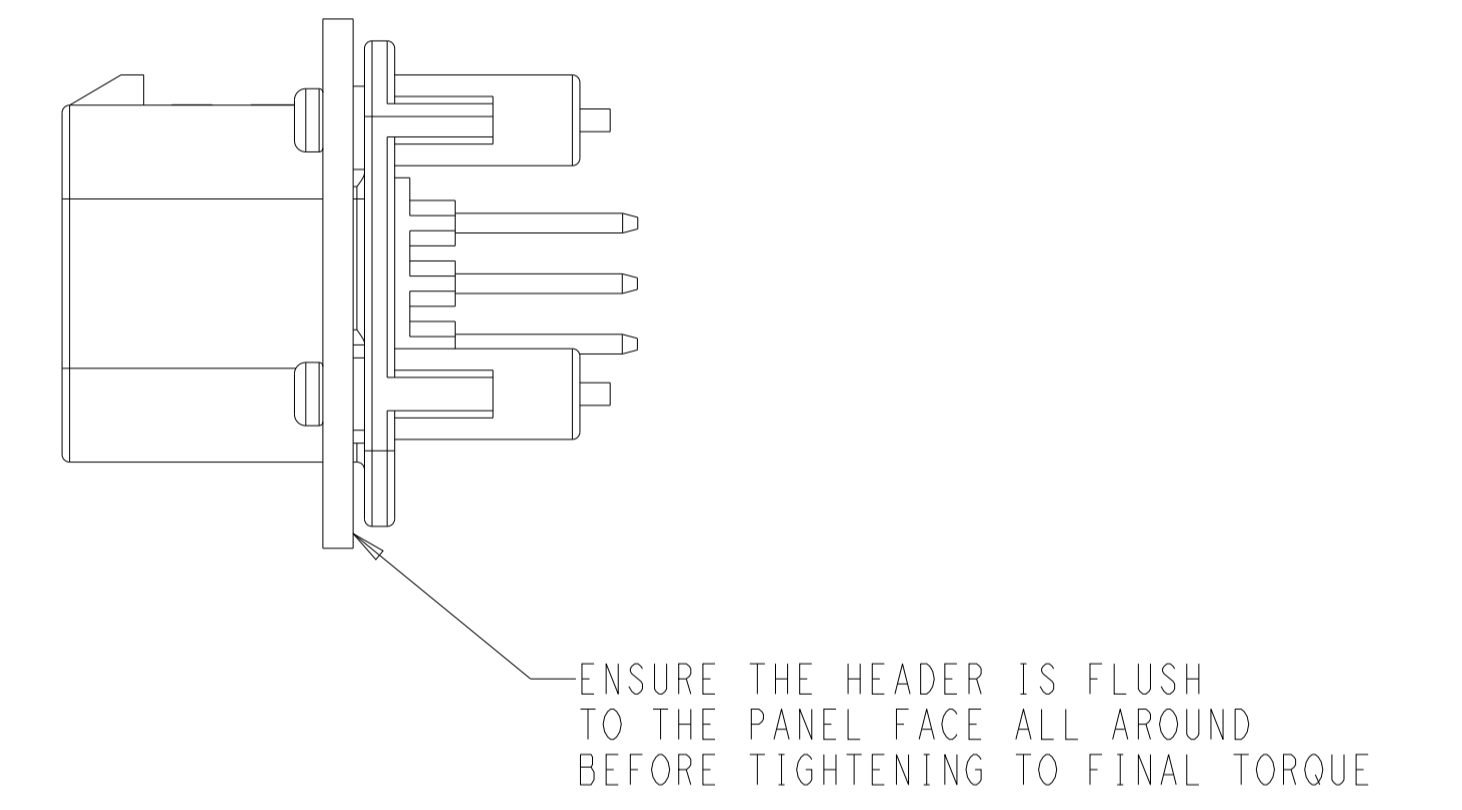

SECTION A-A OPTIONAL CONSTRUCTION IF PANEL THICKNESS IS GREATER THAN 2.0 SCALE 4:1

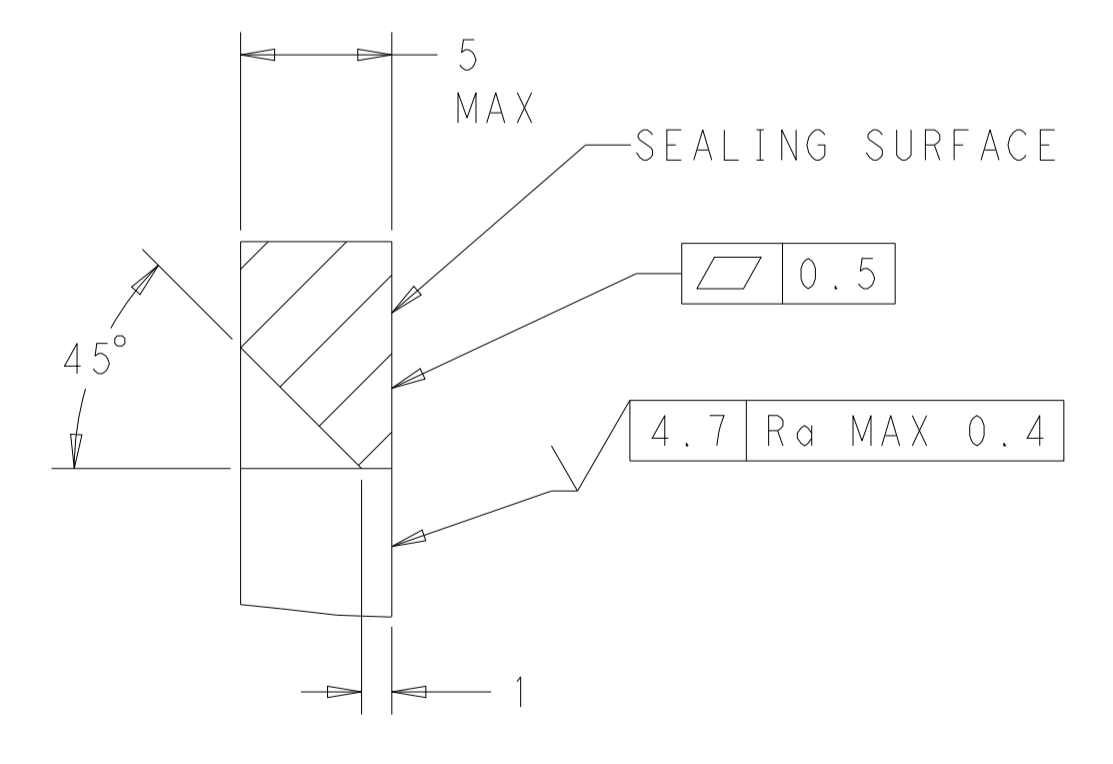

SECTION A-A OPTIONAL CONSTRUCTION IF PANEL THICKNESS IS GREATER THAN 2.0 SCALE 4:1

THIS DRAWING IS A CONTROLLED DOCUMENT.		OWN D. STRAUSSER 04FEB2010	TE Connectivity	
DIMENSIONS: mm		CHK D. STRAUSSER 22MAR2010		
TOLERANCES UNLESS OTHERWISE SPECIFIED:		APVD D. STRAUSSER 27APR2010	NAME HEADER ASSEMBLY, 23 POSITION, VERTICAL, AMPSEAL	
0 PLC ±0.2		PRODUCT SPEC 108-1329	SIZE CAGE CODE DRAWING NO RESTRICTED TO	
1 PLC ±0.2		APPLICATION SPEC 114-16016	A100779C=776200	
2 PLC ±0.2		WEIGHT 22.48g	SCALE 4:1 SHEET 2 OF 2 REV E	
3 PLC ±0.2		CUSTOMER DRAWING		
4 PLC ±0.2				
ANGLES FINISH				

X-ON Electronics

Largest Supplier of Electrical and Electronic Components

Click to view similar products for [Automotive Connectors](#) category:

Click to view products by [TE Connectivity](#) manufacturer:

Other Similar products are found below :

[003-018-000](#) [60403001](#) [60993906-B](#) [M902-2131](#) [M902-2161](#) [72.330.1035.1](#) [73.353.4028.0](#) [F119300-B](#) [F166900](#) [F258300-B](#) [F358300-B](#)
[F407400](#) [F444110](#) [F487000](#) [F509500B-B](#) [827153-1](#) [8N1515-32-24P](#) [9-1326729-8](#) [925474-1](#) [928905-1](#) [964562-4](#) [968782-1](#) [GT17SA-8DS-](#)
[HU](#) [98891-1012](#) [98947-1016](#) [12004147](#) [12004475-L](#) [12010290](#) [12010309-B](#) [12015454](#) [12020219-B](#) [12020308](#) [12041318-B](#) [12052225-L](#)
[12052466](#) [12059125](#) [12064869](#) [12004327-B](#) [12010503-B](#) [12015308](#) [12015384](#) [12015909](#) [1-21030-1](#) [12041254](#) [12041318](#) [12047946-B](#)
[12047957](#) [12047957-L](#) [12059473](#) [12066261](#)