

REVISIONS				
P	LTN	DESCRIPTION	DATE	OWN APVD
C15		REVISED PER ECO-20-004256	25MAR2020	JM DS
C16		REVISED PER PCN E-20-016603	20NOV2020	PN DS
D		REVISED PER ECN-21-123056	08NOV2021	DK CB

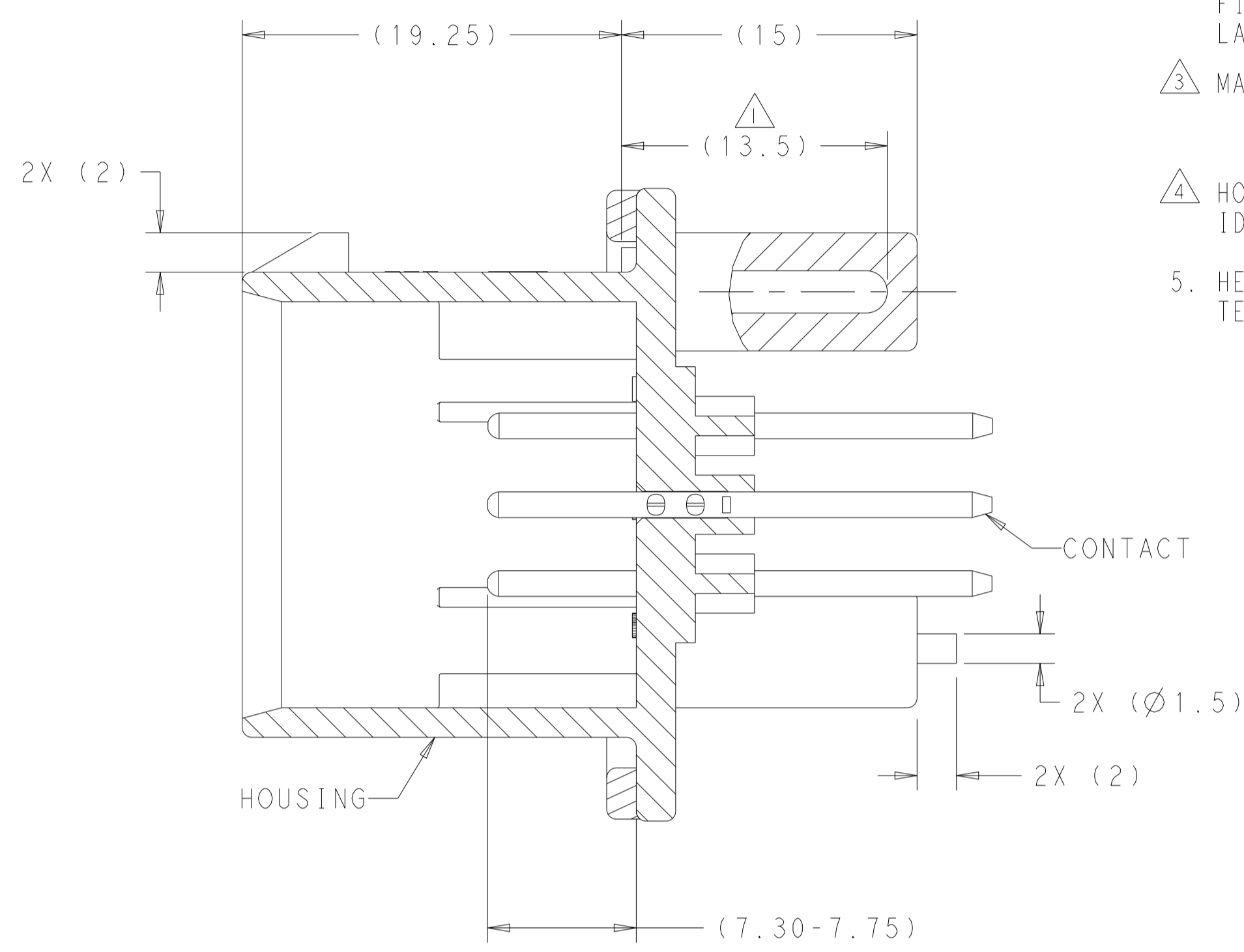

- 1. SUGGESTED MOUNTING SCREW SIZE IS $\varnothing 2.50-3.00\text{mm}$ ($\varnothing 0.099 - 0.118$ INCH) SELF TAPPING THREAD FORMING SCREW, SUCH AS DELTA PT, TO BE DRIVEN AT 0.6-0.8 N-m. THE CUSTOMER SHOULD TEST THE SCREW SIZE AND TYPE IN ORDER TO VERIFY THEIR SELECTION FOR THEIR APPLICATION
- 2. DATE CODE IN THIS LOCATION USING 5 DIGIT CODE. FIRST 2 DIGITS = YEAR, SECOND 2 DIGITS = WEEK, LAST DIGIT = DAY
- 3. MATERIALS: HEADER HOUSING - GLASS FILLED PBT
PINS - TIN OR GOLD PLATED BRASS
GASKET - SILICONE
- 4. HOUSING COLORS ARE MECHANICALLY KEYED TO MATE ONLY WITH IDENTICALLY COLORED PLUG ASSEMBLIES.
- 5. HEADER MATES TO PLUG ASSEMBLY 770680 WHICH USES REELED TERMINAL 770520 OR LOOSE PIECE TERMINAL 770854

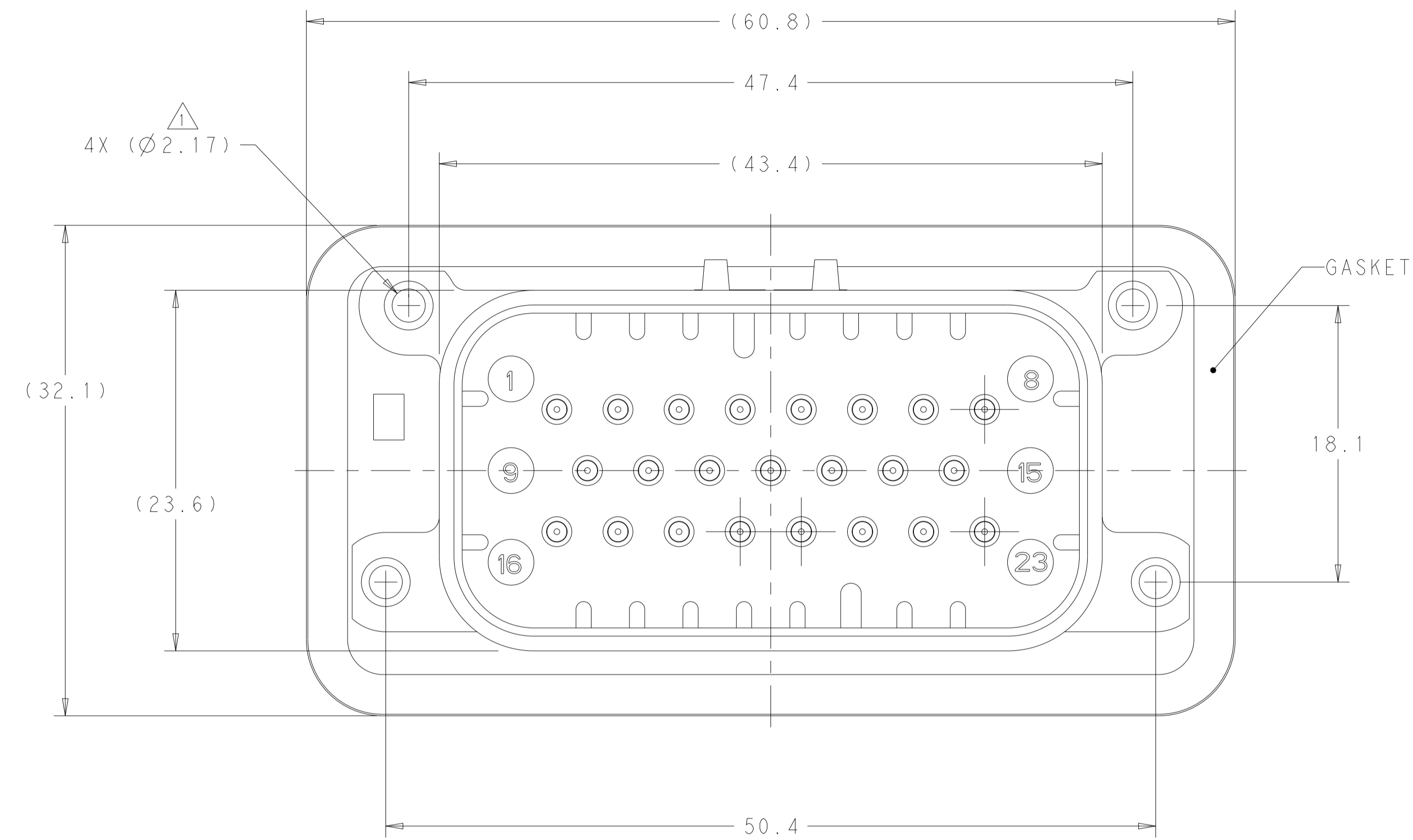
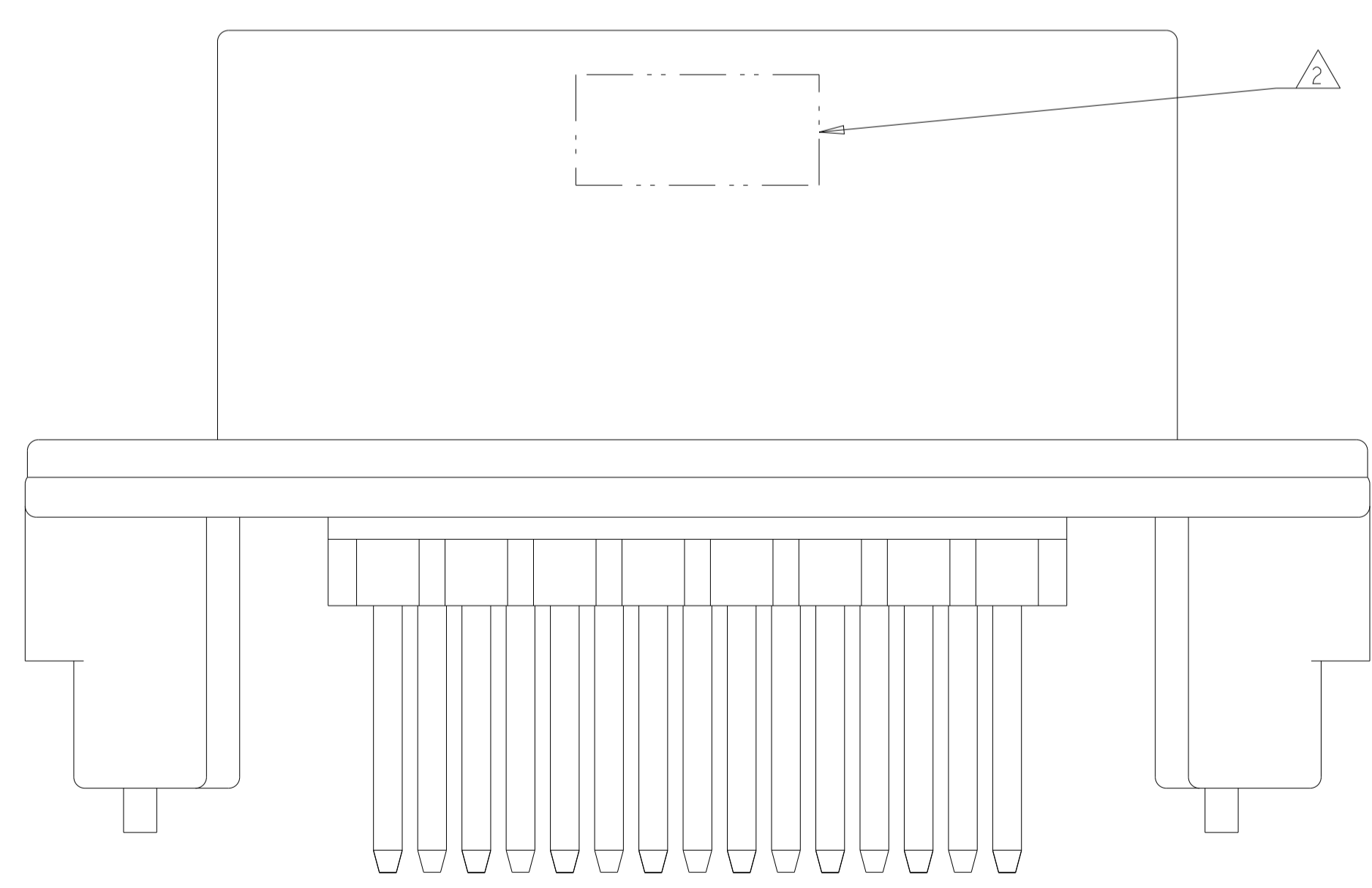

SECTION A-A

776228-1 & 1-776228-1 SHOWN

BLUE	GOLD	1-776228-5
GRAY	GOLD	1-776228-4
NATURAL	GOLD	1-776228-2
BLACK	GOLD	1-776228-1
BLUE	TIN	776228-5
GRAY	TIN	776228-4
NATURAL	TIN	776228-2
BLACK	TIN	776228-1
HEADER COLOR	PLATING	PART NUMBER

THIS DRAWING IS A CONTROLLED DOCUMENT.		OWN D. STRAUSSER 25MAR2020	APVD D. STRAUSSER 27APR2020	NAME ASSEMBLY, HEADER, 23 POSITION, VERTICAL, AMPSEAL WITH FLANGE SEAL
DIMENSIONS:	TOLERANCES UNLESS OTHERWISE SPECIFIED:	PRODUCT SPEC 108-1329	APPLICATION SPEC 114-16016	RESTRICTED TO
mm	0 PLC ± 1 PLC ±0.2 2 PLC ± 3 PLC ± 4 PLC ± ANGLES ± FINISH ±	WEIGHT 22.68g	SIZE A1	SCALE 4:1
MATERIAL	FINISH	CUSTOMER DRAWING	SCALE 4:1	SHEET 1 OF 2

REVISIONS				
P.	LTN.	DESCRIPTION	DATE	APPV.
-	-	SEE SHEET 1	-	-

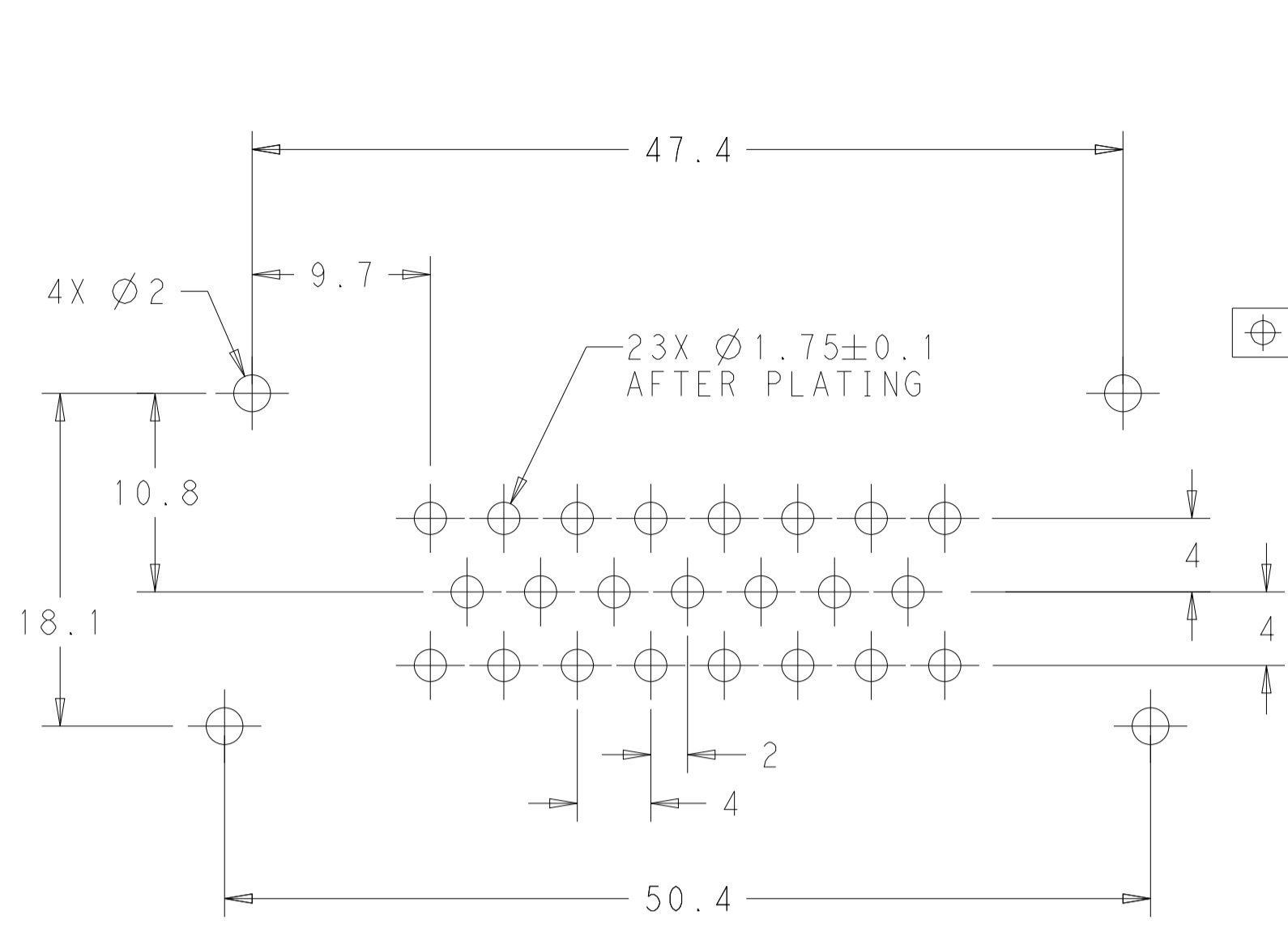

RECOMMENDED P.C. BOARD LAYOUT FOR 1.57 THICK P.C. BOARD

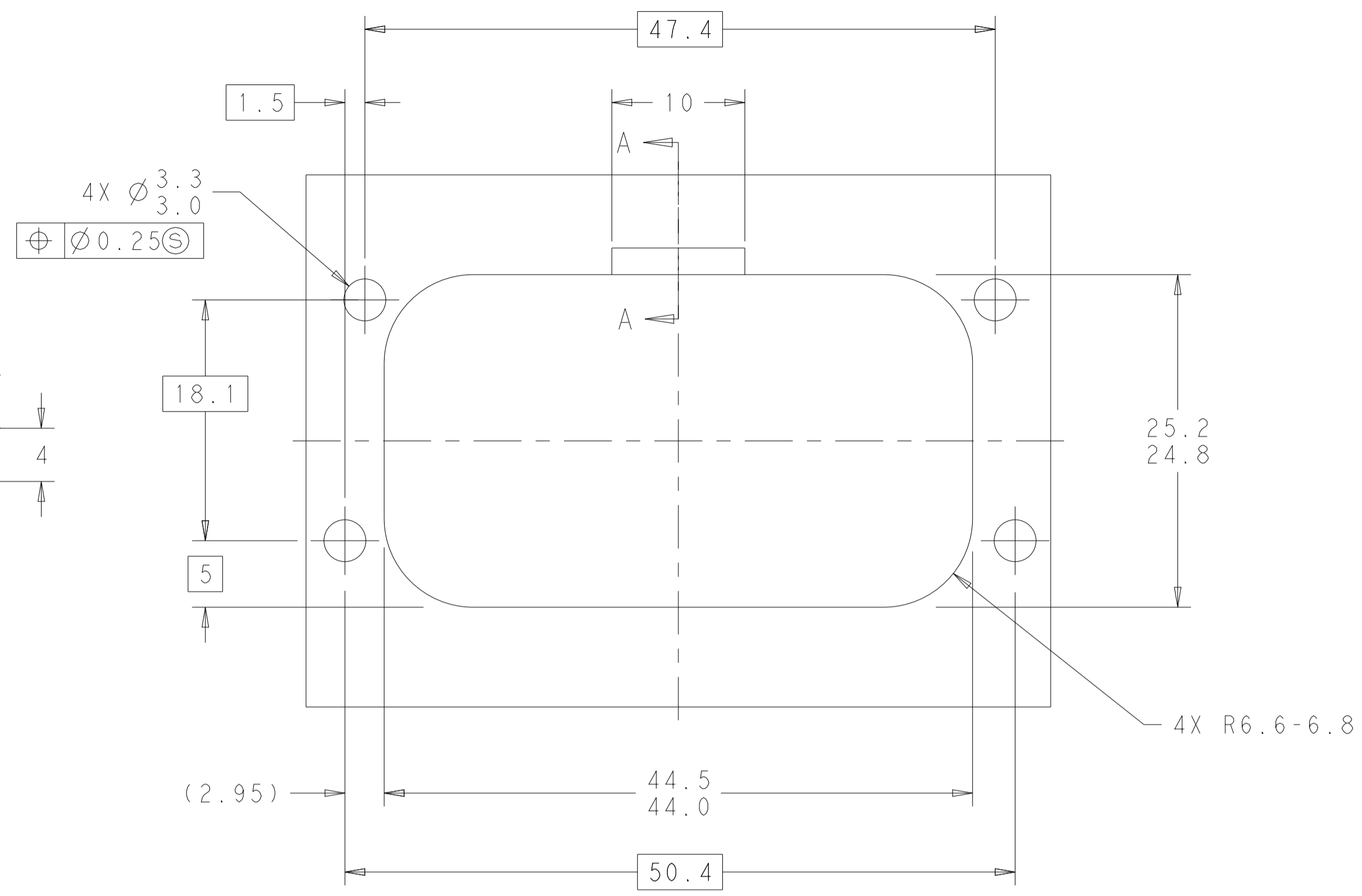

RECOMMENDED MOUNTING HOLE LAYOUT FOR 5.0 MAX THICK PANEL

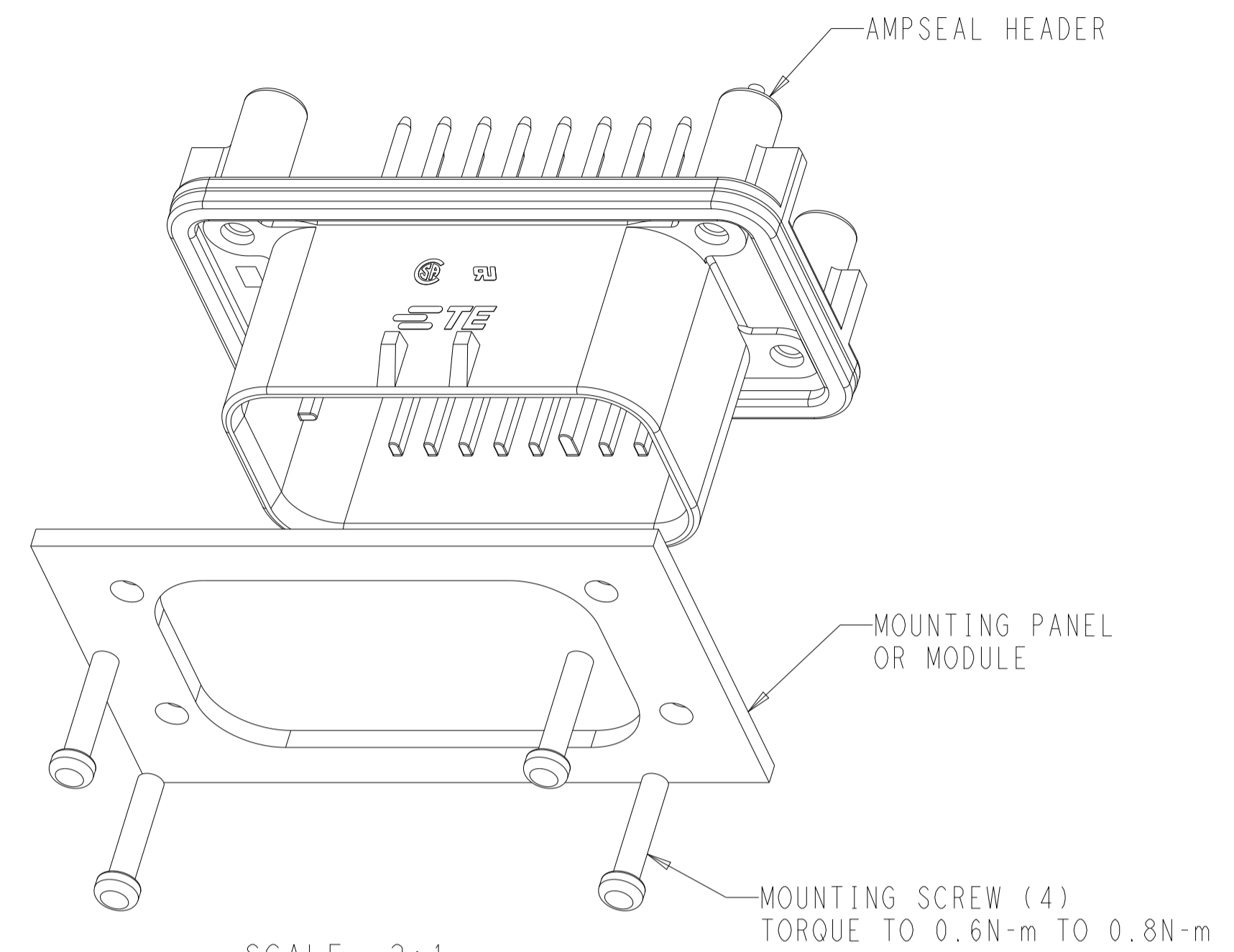

SCALE 2:1

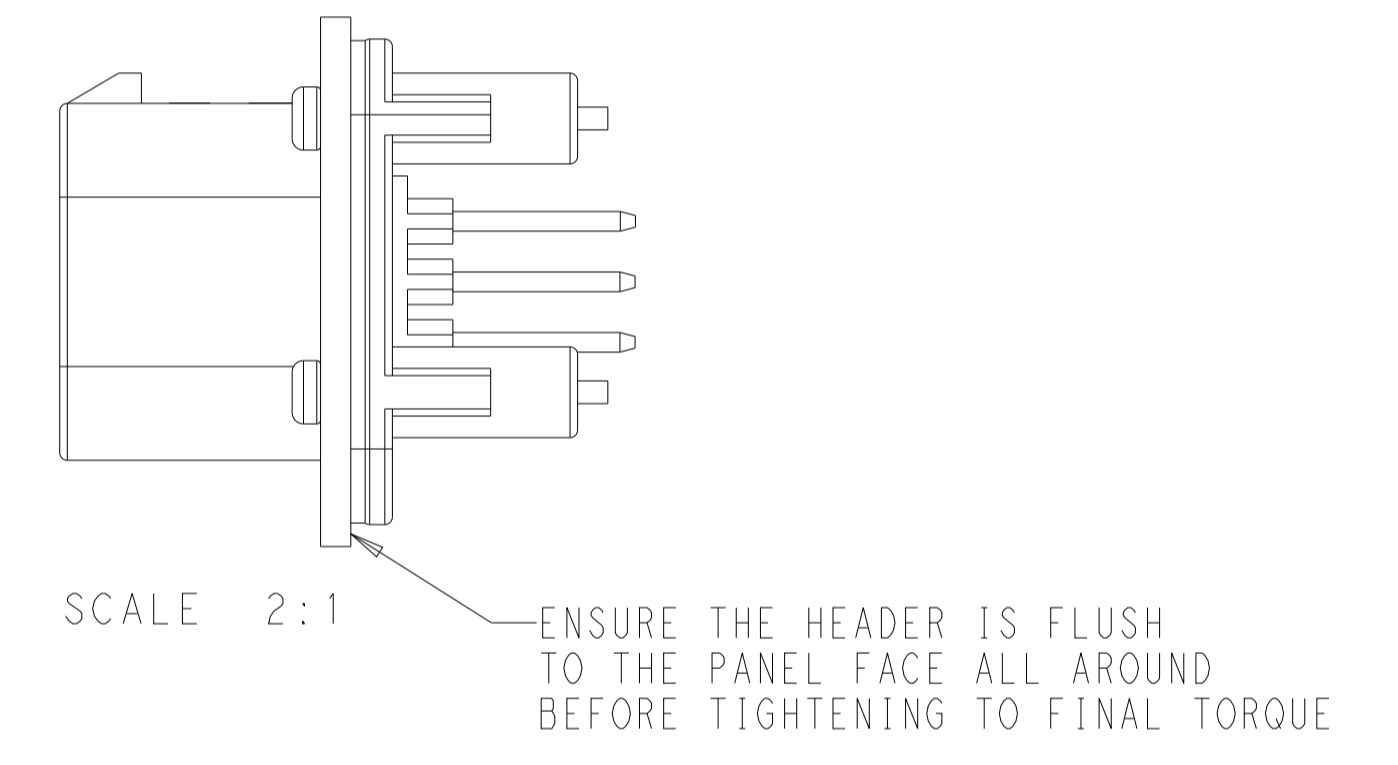

SCALE 2:1

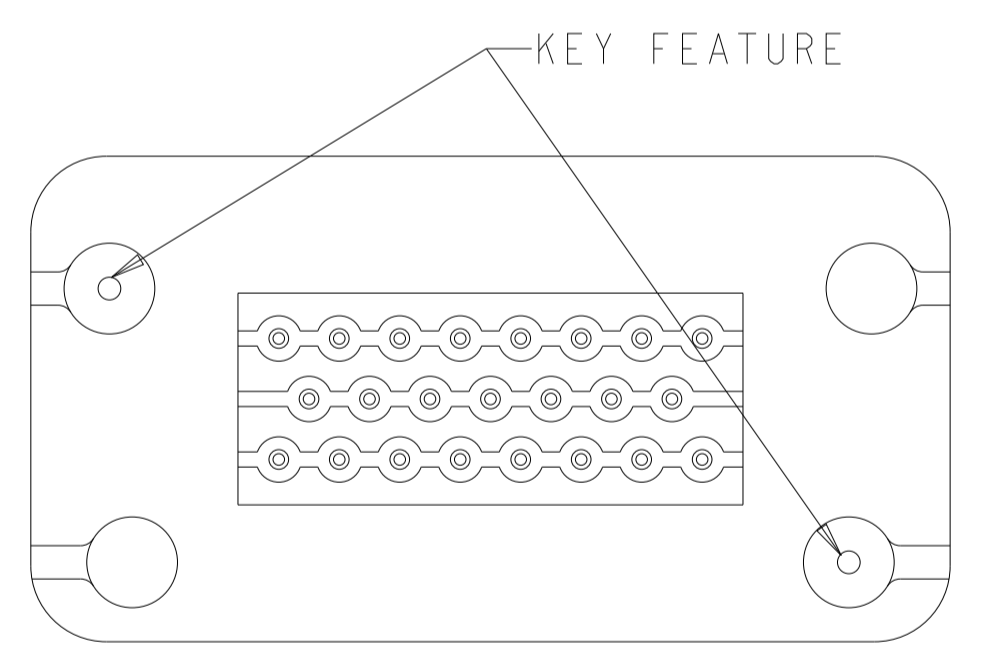

KEYING FOR 776228-1 AND 776228-5 SCALE 2:1

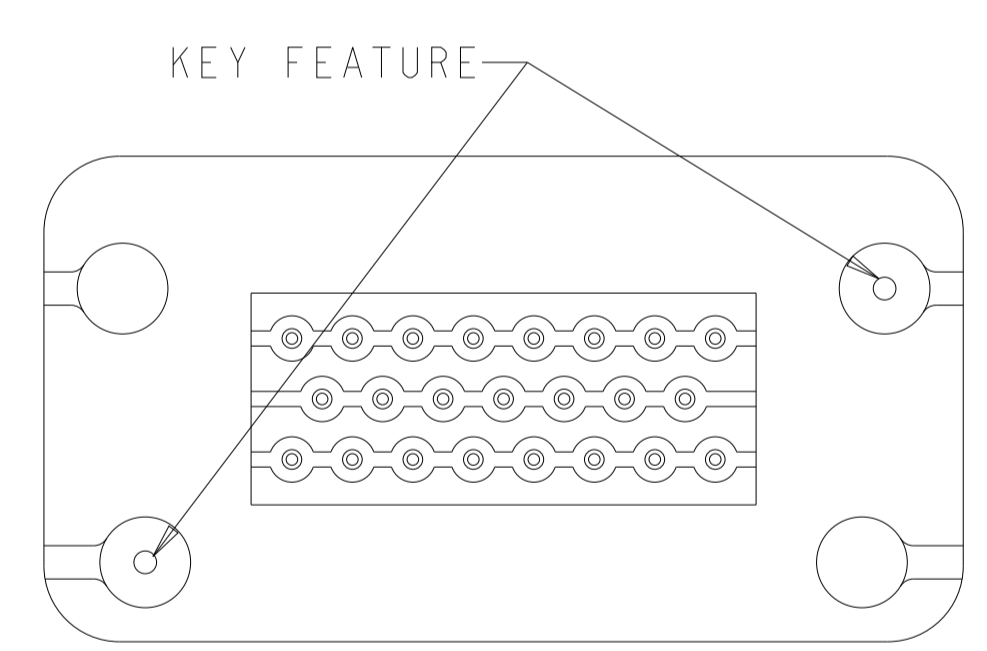

KEYING FOR 776228-2 AND 776228-4 SCALE 2:1

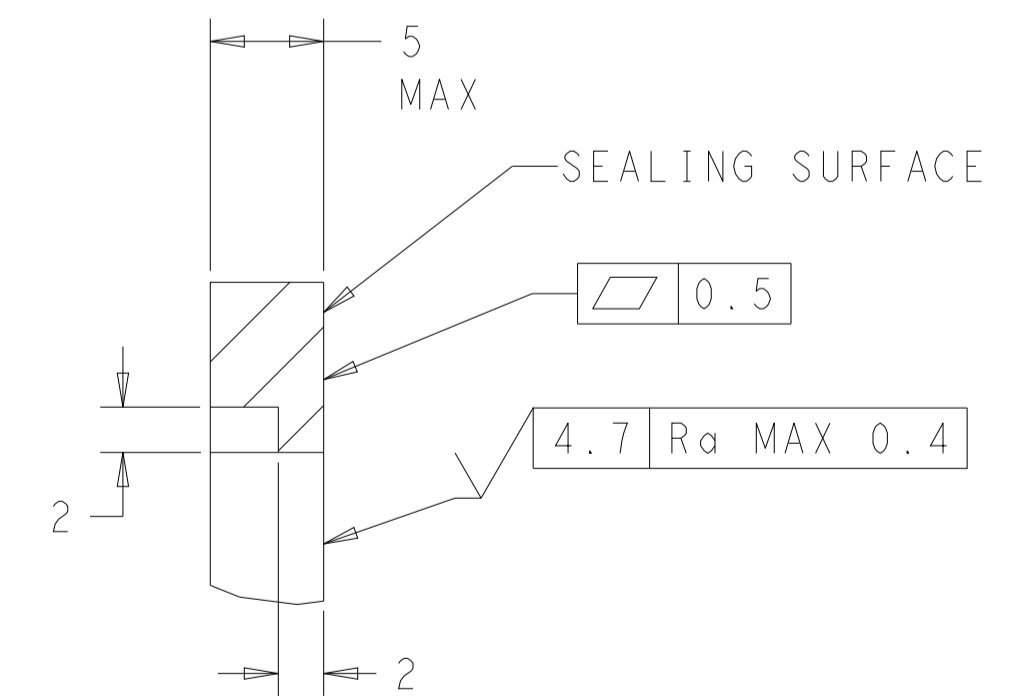

SECTION A-A
OPTIONAL CONSTRUCTION IF PANEL THICKNESS IS GREATER THAN 2.0

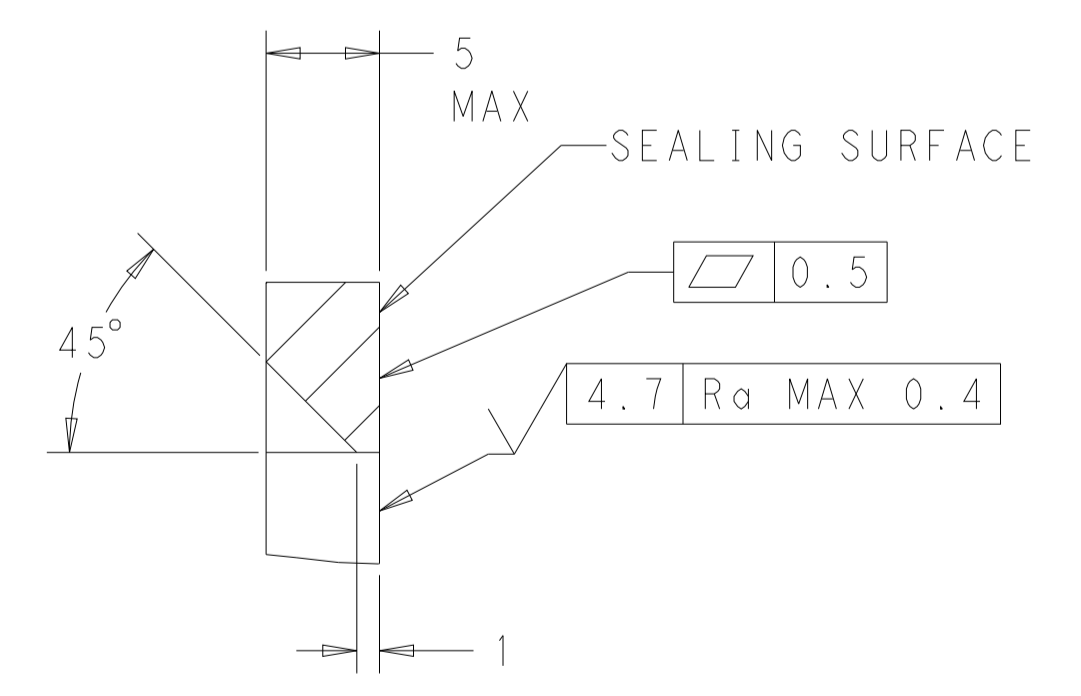

SECTION A-A
OPTIONAL CONSTRUCTION IF PANEL THICKNESS IS GREATER THAN 2.0

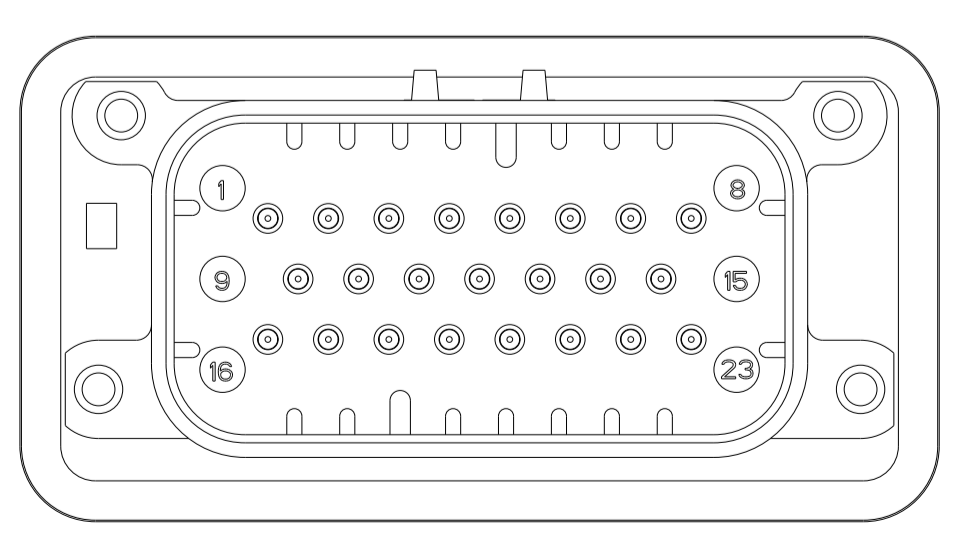

776228-2 & 1-776228-2
KEY LOCATION
SCALE 2:1

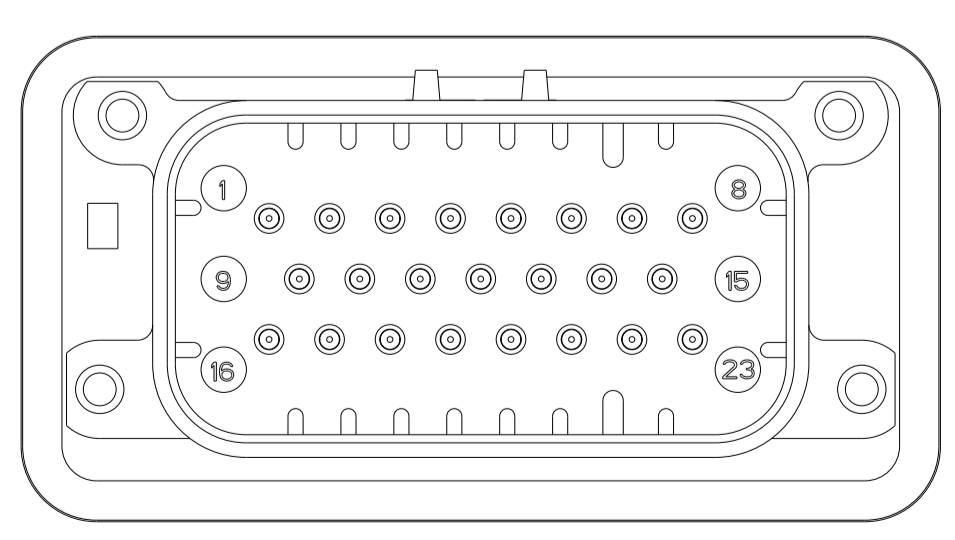

776228-4 & 1-776228-4
KEY LOCATION
SCALE 2:1

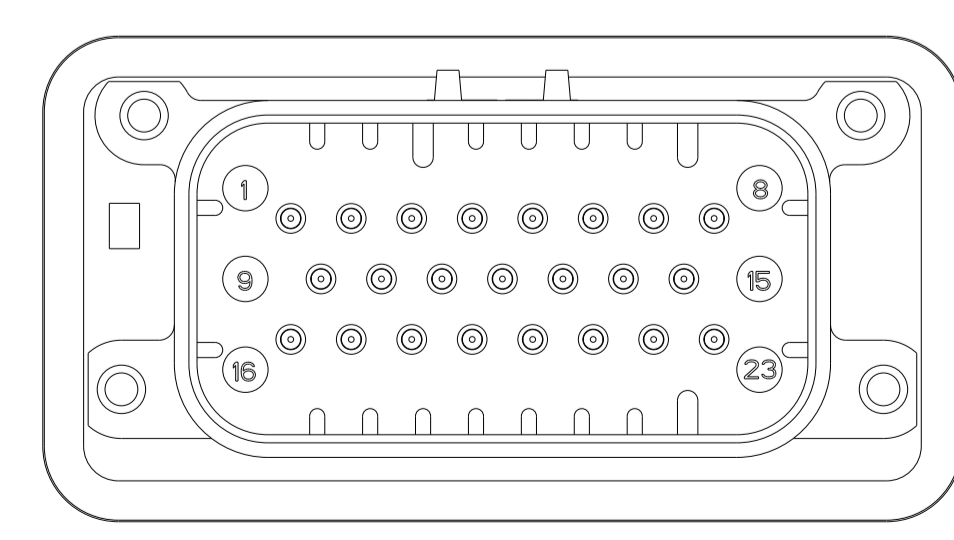

776228-5 & 1-776228-5
KEY LOCATION
SCALE 2:1

THIS DRAWING IS A CONTROLLED DOCUMENT.		OWN: D. STRAUSSER 05MAR2010	STE TE Connectivity	
DIMENSIONS:		CHK: D. STRAUSSER 22MAR2010	NAME: ASSEMBLY, HEADER, 23 POSITION, VERTICAL, AMPSEAL WITH FLANGE SEAL	
mm	TOLERANCES UNLESS OTHERWISE SPECIFIED:	APPV: D. STRAUSSER 27APR2010	PRODUCT SPEC: 108-1329	RESTRICTED TO: -
Ø	0 PLC ±0.2	APPLICATION SPEC: 114-16016	SIZE: A1	CAGE CODE: 00779
∅	1 PLC ±0.2	WEIGHT: 22.68g	DRAWING NO: 776228	SCALE: 2:1
∅	2 PLC ±0.2	CUSTOMER DRAWING	SHEET: 2 OF 2	REV: D
∅	3 PLC ±0.2			
∅	4 PLC ±0.2			
∅	ANGLES ±0.5			
∅	FINISH ±0.4			

X-ON Electronics

Largest Supplier of Electrical and Electronic Components

Click to view similar products for [Automotive Connectors](#) category:

Click to view products by [TE Connectivity](#) manufacturer:

Other Similar products are found below :

[003-018-000](#) [60403001](#) [60993906-B](#) [M902-2131](#) [M902-2161](#) [M902-2344](#) [72.330.1035.1](#) [73.353.4028.0](#) [F119300-B](#) [F166900](#) [F258300-B](#)
[F358300-B](#) [F407400](#) [F444110](#) [F487000](#) [F509500B-B](#) [827153-1](#) [8N1515-32-24P](#) [9-1326729-8](#) [925474-1](#) [928905-1](#) [964562-4](#) [968782-1](#)
[GT17SA-8DS-HU](#) [98891-1012](#) [98947-1016](#) [12004147](#) [12004475-L](#) [12010290](#) [12010309-B](#) [12015454](#) [12020219-B](#) [12041318-B](#) [12052225-](#)
[L](#) [12052466](#) [12064869](#) [12004327-B](#) [12015308](#) [12015384](#) [12015909](#) [1-21030-1](#) [12041254](#) [12041318](#) [12047946-B](#) [12047957](#) [12047957-L](#)
[12059473](#) [12066261](#) [12110546](#) [12110546-B](#)