

THIS DRAWING IS UNPUBLISHED. RELEASED FOR PUBLICATION  
 © COPYRIGHT BY TYCO ELECTRONICS CORPORATION. ALL RIGHTS RESERVED.

LOC	DIST	REVISIONS			
P	LTR	DESCRIPTION	DATE	DWN	APVD
	B	REVISED PER ECO-07-029494	2/8/08	SS	MW

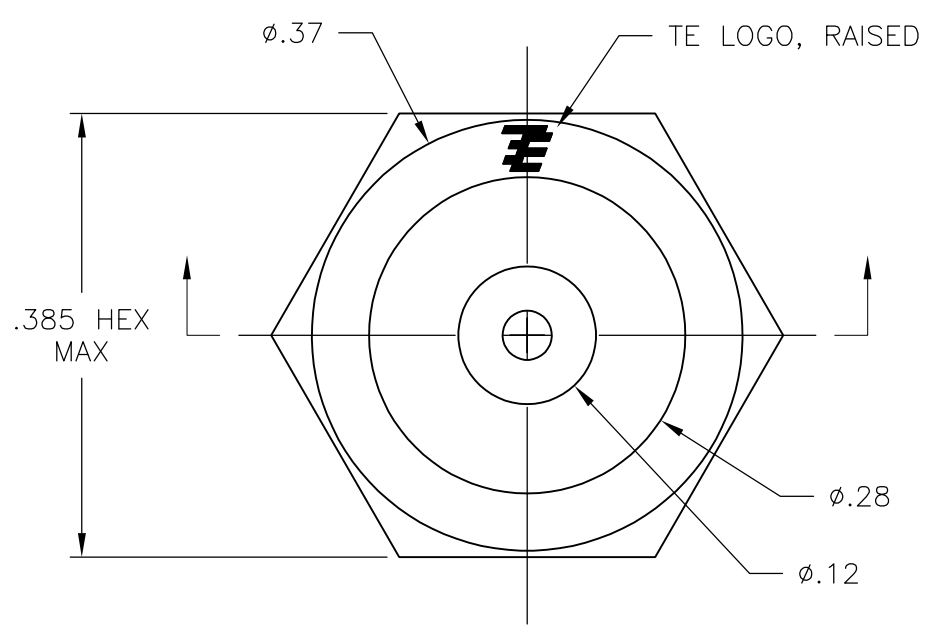

1. ALL COLORS AND MATERIALS MADE FROM ONE TOOL.
  2. SOME DIMENSIONS MAY VARY DUE TO DIFFERENT COMPOUND SHRINKAGE FACTOR.
  3. MINOR FLASH ACCEPTABLE ON INSERT THREAD.
  4. BLACK FINISH/NICKEL PLATING ON INSIDE THREADS REMOVED DUE TO MOLDING PROCESS PERMITTED.
  5. RUBBER TO METAL BOND MUST MEET OR EXCEED THE TEAR STRENGTH OF RUBBER.
  6. RUBBER OVERLAY IS PERMISSIBLE OVER HEX FLATS AS SHOWN IN THE DRAWING.
- △ TREAT WITH PERMANENT LUBRICANT.
8. COMPONENTS MUST COMPLY WITH EU DIRECTIVE 2002/95/EC ON RESTRICTION OF THE USE OF CERTAIN HAZARDOUS SUBSTANCES IN ELECTRICAL AND ELECTRONICS EQUIPMENT (ROHS).

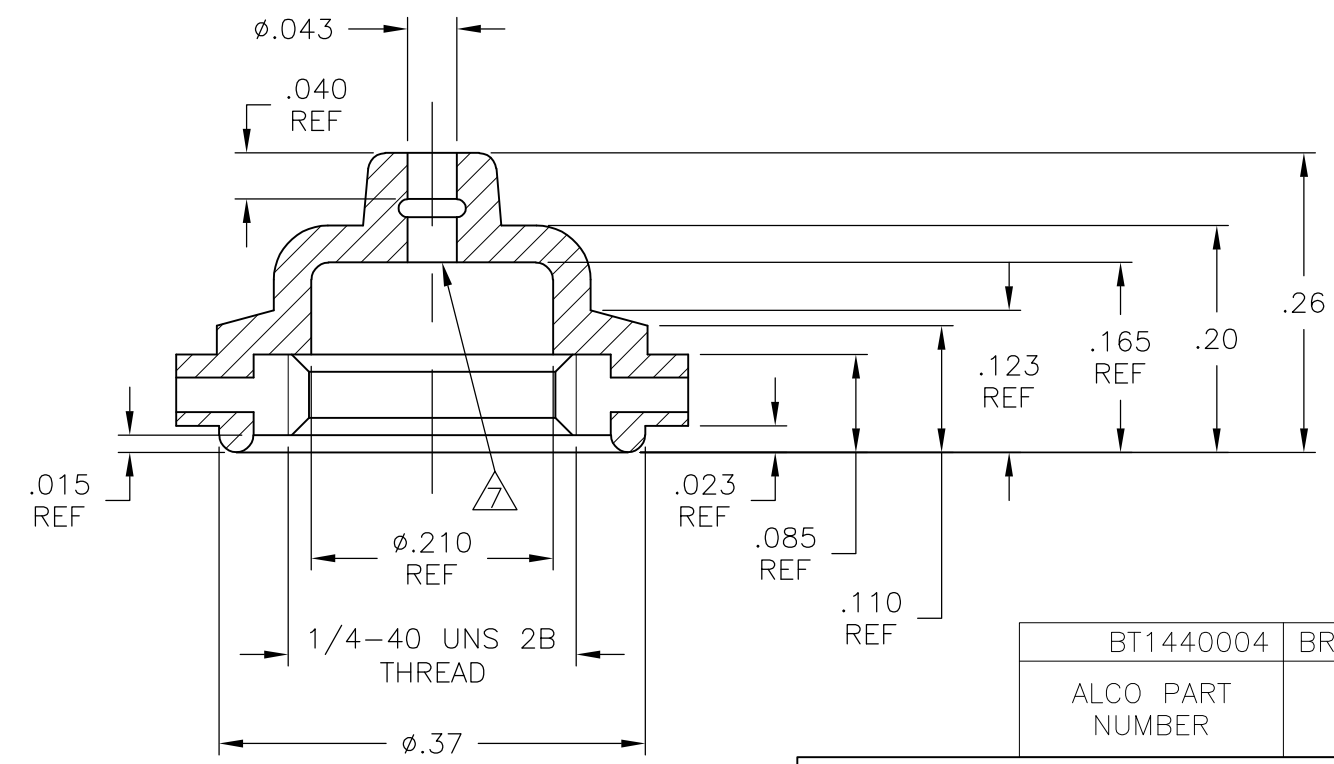

BT1440004	BRASS, BLACK OXIDE PER MIL-F-495	SILICONE, COLOR BLACK	1825619-1
ALCO PART NUMBER	HEX NUT MATERIAL	RUBBER BOOT MATERIAL	PART NUMBER

THIS DRAWING IS A CONTROLLED DOCUMENT.		DWN S SCHLEGEL 08FEB2008	Tyco Electronics Corporation Harrisburg, PA 17105-3608	
DIMENSIONS: INCHES		CHK M WILBOURN 2/8/08	NAME 1/4-40 TOGGLE SWITCH BOOT SEAL	
TOLERANCES UNLESS OTHERWISE SPECIFIED:		APVD M WILBOURN 2/8/08	PRODUCT SPEC	
0 PLC ± -		APPLICATION SPEC		
1 PLC ± -		SIZE A3		
2 PLC ± .01		CAGE CODE 00779		
3 PLC ± .005		DRAWING NO C-1825619		
4 PLC ± -		RESTRICTED TO		
ANGLES ± 5'		WEIGHT -		
MATERIAL -		CUSTOMER DRAWING		
FINISH -		SCALE 6:1		
		SHEET 1 OF 1		
		REV B		

## X-ON Electronics

Largest Supplier of Electrical and Electronic Components

*Click to view similar products for te connectivity manufacturer:*

Other Similar products are found below :

[570416-000](#) [CLTEQ-M81CE-SSRELAY-4-20V](#) [4-1633138-8](#) [D38999/24FJ4AN](#) [4-1195131-0](#) [650069-000](#) [SMD100-2](#) [2EDL4CM](#)  
[DTS20W19-11PD-3028](#) [DTS20W19-11PD-3028-LC](#) [DTS20W19-32SD-3028-LC](#) [DTS20W19-32SD-3028](#) [NC6-P104-06](#) [TXR64AB90-](#)  
[3616AI](#) [DTS26F21-41HE](#) [DTS26F21-41AE](#) [DTS26F21-41PE-LC](#) [DTS26F21-11SE-3028-LC](#) [D38999/24WF32JE](#) [D38999/24WF32SE-LC](#)  
[DTS24W19-32HE](#) [5-2027513-8](#) [D38999/20JB35HA](#) [D38999/24WJ20PA](#) [164-8033-08](#) [D38999/24FF32JE](#) [D38999/24FF32SE-LC](#)  
[D38999/24WF32JB](#) [D38999/24WG11HA](#) [D38999/24WG11HN](#) [MS27467T21F11H](#) [DJT16E21-11HA](#) [DTS24F19-32HE](#) [1-532955-3](#)  
[DTS20W19-32SA-3028-LC](#) [DTS24F19-11SC-3028-LC](#) [DTS24F19-11SC-3028](#) [DJT14E13-98HB](#) [D38999/20WC8BB](#) [1-330599-5](#)  
[DTS24F21-41HN-LC](#) [DTS24F21-41HN](#) [DTS24F21-41AN](#) [DTS24F21-39HN](#) [DTS24F21-41PN-LC](#) [AFD50-10-6SN-1A-LC](#) [DBAS 70-7-0](#)  
[SN 090-1A SCC](#) [DJT10F17-26HC](#) [DTS24W19-32HB](#) [ACT20JE99HA](#)