

- ① THESE SURFACES WILL NOT BE PLATED
- ② THE NOTED DIMENSIONS APPLY AT THE INTERSECTION OF THE POST AND THE HOUSING
- ③ .000100-.000200 TIN LEAD OVER .000030 NICKEL.
- ④ .000100-.000200 TIN OVER .000030 NICKEL.
- ⑤ PRELIMINARY PART
- ⑥ ROHS 2002/95/EC COMPLIANT.
- ⑦ OBSOLETE PARTS: OBSOLETE CIS STREAMLINING PER D.RENAUD/D.SINISI

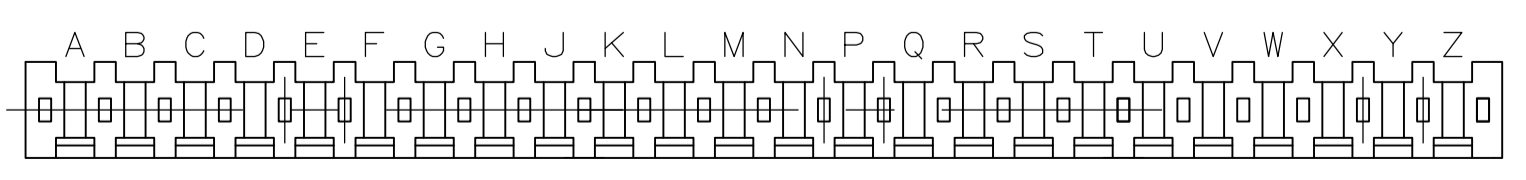
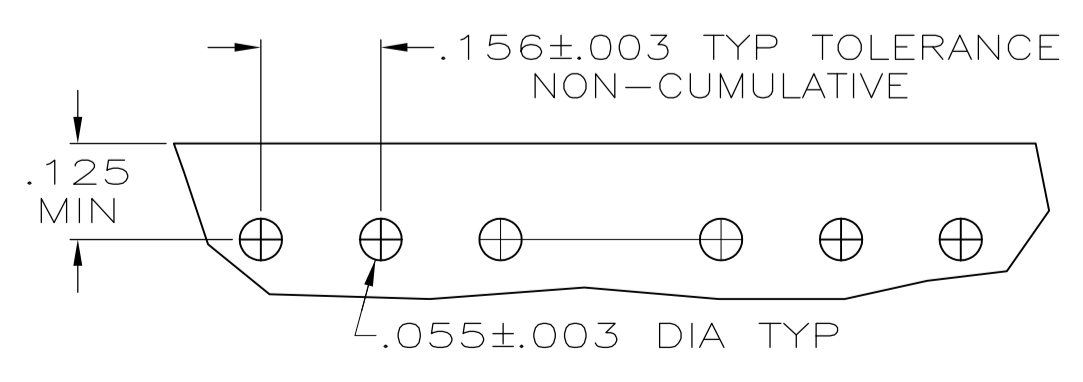

KEYWAY LOCATIONS (REF-SEE TABLE)
(MATING LENGTH OF POST ON NEAR SIDE)
SCALE: 2:1

FINISH	KEYWAY LOCATIONS	NO OF KEYWAY	C	B	A	NO OF POSN	ASSEMBLY PART NUMBER
	NONE	0	.111	-	-	1	7-87160-6
	A,C,E,H,K,M,Q,S,U,W,Y	11	3.855	3.744	24	25	7-87160-5
	A,C,E,G,J,L,N,Q,S,U,W,Y	12	3.699	3.588	23	24	7-87160-4
	A,D,G,K,N,R,U,X	8	3.543	3.432	22	23	7-87160-3
	A,C,E,G,J,L,N,Q,S,U,W	11	3.387	3.276	21	22	7-87160-2
	A,D,G,K,N,R,U	7	3.231	3.120	20	21	7-87160-1
	A,C,E,G,J,L,N,Q,S,U	10	3.075	2.964	19	20	7-87160-0
	B,D,F,J,L,N,Q,S	8	2.919	2.808	18	19	6-87160-9
	A,D,F,J,M,P,S	7	2.763	2.652	17	18	6-87160-8
	A,D,G,K,N,R	6	2.607	2.496	16	17	6-87160-7
	A,C,E,G,J,L,N,Q	8	2.451	2.340	15	16	6-87160-6
	A,D,G,K,N	5	2.295	2.184	14	15	6-87160-5
	A,C,E,G,J,L,N	7	2.139	2.028	13	14	6-87160-4
	A,C,E,G,J,L	6	1.827	1.716	11	12	6-87160-3
	A,D,G,K	4	1.671	1.560	10	11	6-87160-2
	A,C,E,G,J	5	1.515	1.404	9	10	6-87160-1
	A,D,G	3	1.359	1.248	8	9	6-87160-0
	A,C,E,G	4	1.203	1.092	7	8	5-87160-9
	A,C,E	3	1.047	.936	6	7	5-87160-8
	A,C,E	3	.891	.780	5	6	5-87160-7
	A,C	2	.579	.468	3	4	5-87160-6
	A	1	.423	.312	2	3	5-87160-5
	A	1	.267	.156	1	2	5-87160-4
	A,D,J,M	4	1.983	1.872	12	13	5-87160-2
	A,D	2	.735	.624	4	5	5-87160-1
	A	1	.267	.156	1	2	3-87160-7
	NONE	0	5.415	5.304	34	35	3-87160-6
	NONE	0	5.259	5.148	33	34	3-87160-5
	NONE	0	5.103	4.992	32	33	3-87160-4
	NONE	0	4.947	4.836	31	32	3-87160-3
	NONE	0	4.791	4.680	30	31	3-87160-2
	NONE	0	4.635	4.524	29	30	3-87160-1
	NONE	0	4.479	4.368	28	29	3-87160-0
	NONE	0	4.323	4.212	27	28	2-87160-9
	NONE	0	4.167	4.056	26	27	2-87160-8
	NONE	0	4.011	3.900	25	26	2-87160-7
	NONE	0	.111	-	-	1	2-87160-6
	A,C,E,H,K,M,Q,S,U,W,Y	11	3.855	3.744	24	25	2-87160-5
	A,C,E,G,J,L,N,Q,S,U,W,Y	12	3.699	3.588	23	24	2-87160-4
	A,D,G,K,N,R,U,X	8	3.543	3.432	22	23	2-87160-3
	A,C,E,G,J,L,N,Q,S,U,W	11	3.387	3.276	21	22	2-87160-2
	A,D,G,K,N,R,U	7	3.231	3.120	20	21	2-87160-1
	A,C,E,G,J,L,N,Q,S,U	10	3.075	2.964	19	20	2-87160-0
	B,D,F,J,L,N,Q,S	8	2.919	2.808	18	19	1-87160-9
	A,D,F,J,M,P,S	7	2.763	2.652	17	18	1-87160-8
	A,D,G,K,N,R	6	2.607	2.496	16	17	1-87160-7
	A,C,E,G,J,L,N,Q	8	2.451	2.340	15	16	1-87160-6
	A,D,G,K,N	5	2.295	2.184	14	15	1-87160-5
	A,C,E,G,J,L,N	7	2.139	2.028	13	14	1-87160-4
	A,C,E,G,J,L	6	1.827	1.716	11	12	1-87160-3
	A,D,G,K	4	1.671	1.560	10	11	1-87160-2
	A,C,E,G,J	5	1.515	1.404	9	10	1-87160-1
	A,D,G	3	1.359	1.248	8	9	1-87160-0
	A,C,E,G	4	1.203	1.092	7	8	87160-9
	A,C,E	3	1.047	.936	6	7	87160-8
	A,C,E	3	.891	.780	5	6	87160-7
	A,C	2	.579	.468	3	4	87160-6
	A	1	.423	.312	2	3	87160-5
	A	1	.267	.156	1	2	87160-4
	A	1	.267	.156	1	2	87160-3
	A,D,J,M	4	1.983	1.872	12	13	87160-2
	A,D	2	.735	.624	4	5	87160-1

THIS DRAWING IS A CONTROLLED DOCUMENT.

DIN L.A.MAYER 3-16-87
CHK: F.B.HURBEN 3-18-87
APVD: J.SCHIEFFER 3-18-87

TE Connectivity

HEADER ASSEMBLY, MOD I, VERTICAL, SINGLE ROW, .156

SIZE: A1 CASE CODE: 00779 DRAWING NO: 87160

RESTRICTED TO: -

CUSTOMER DRAWING SCALE: 4:1 SHEET: 1 OF 1 REV: U3

X-ON Electronics

Largest Supplier of Electrical and Electronic Components

Click to view similar products for [Headers & Wire Housings](#) category:

Click to view products by [TE Connectivity](#) manufacturer:

Other Similar products are found below :

[892-18-020-10-001101](#) [58102-G61-06LF](#) [582553-1](#) [0009485154](#) [009176003701906](#) [0050291907](#) [LY20-4P-DT1-P1E-BR](#) [02.125.8002.8](#)
[609-3404](#) [61062-3](#) [61082-181009](#) [622-3653LF](#) [63453-116](#) [636-1030](#) [636-1427](#) [636-3427](#) [636-4007](#) [641938-9](#) [641991-4](#) [644827-2](#) [65817-](#)
[010LF](#) [65817-015LF](#) [65863-015LF](#) [66207-023LF](#) [67095-007LF](#) [67601157](#) [68645-018](#) [68648-049](#) [70.362.1628.0](#) [70-4210](#) [70-4226B](#) [70-](#)
[4853B](#) [707-5020](#) [707-5028](#) [71.350.2428.0](#) [71918-208LF](#) [71961-016LF](#) [733-134](#) [733-162](#) [754199-000](#) [760-3052](#) [79531-3000](#) [FCN-](#)
[360C032-B](#) [FCN-367T-T012/H](#) [FCN-723D010/2](#) [80.063.4001.1](#) [800-90-001-10-001000](#) [800-90-010-10-002000](#) [801-43-002-10-013000](#)
[801-43-006-10-002000](#)