

REVISONS		DATE	DWH	APVD
LOC	DIST			
A1	-			
B48	ECR-20-008727	22JAN2020	DC	FL
B49	ECN-20-100216	21JAN2020	DC	FL
B50	ECR-20-101113	22DEC2020	PJ	FL
B51	ECR-21-100139	12JAN2021	KD	FL

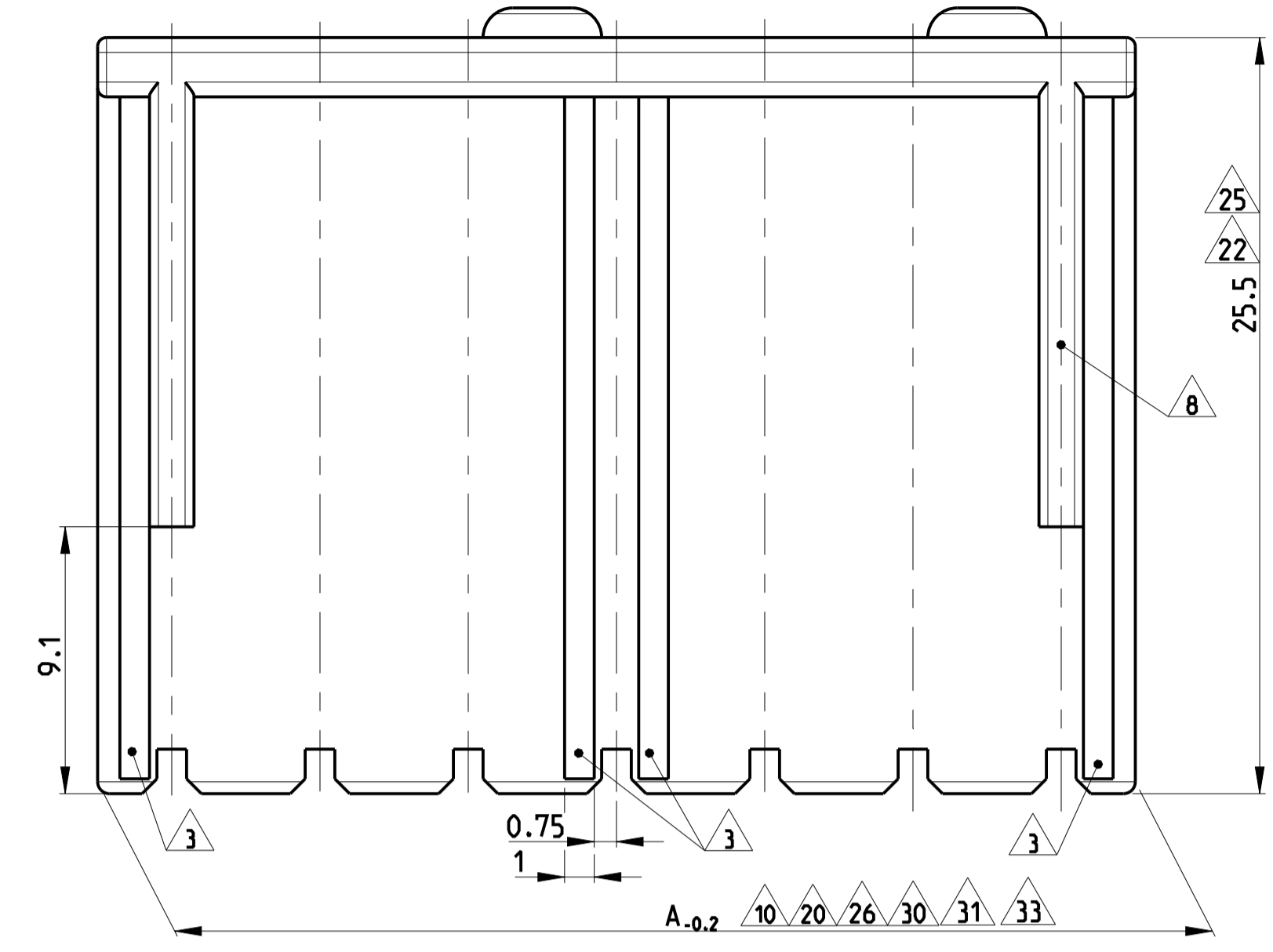

DESCRIPTION
POSITION OF THE KEYING RIBS, POLARISATION RIBS AND THE LOCKING LATCH

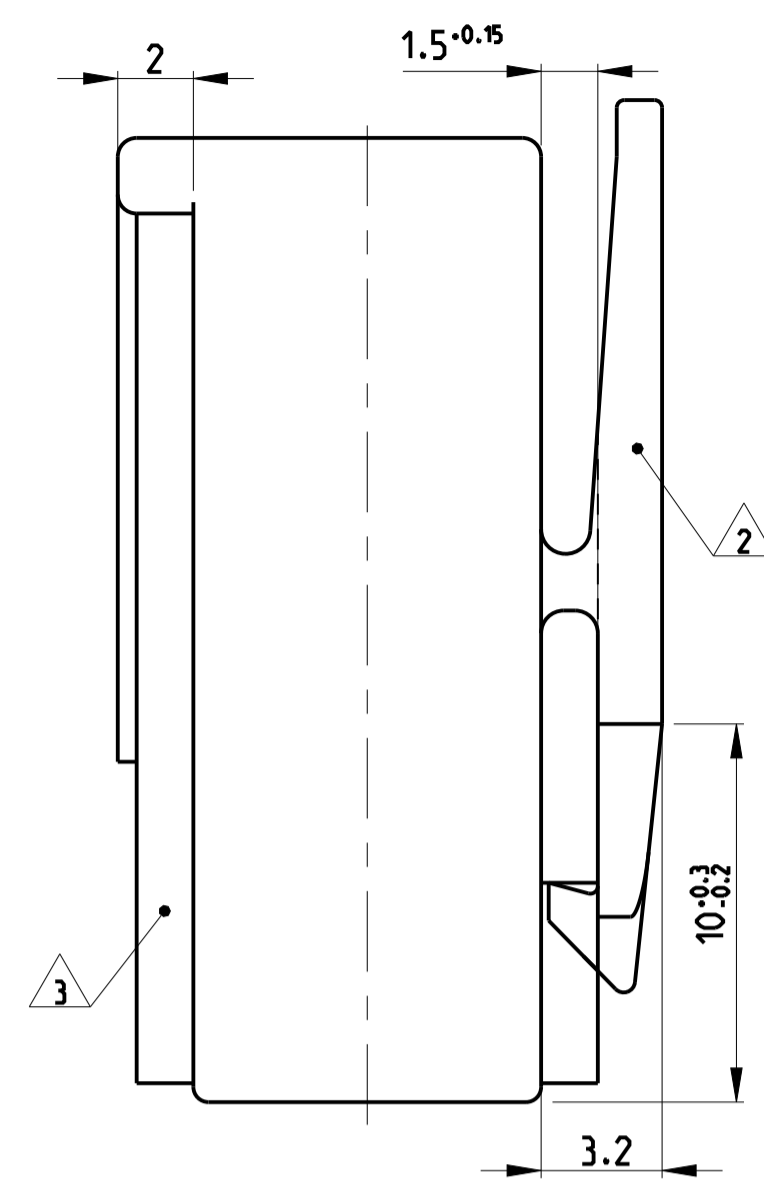
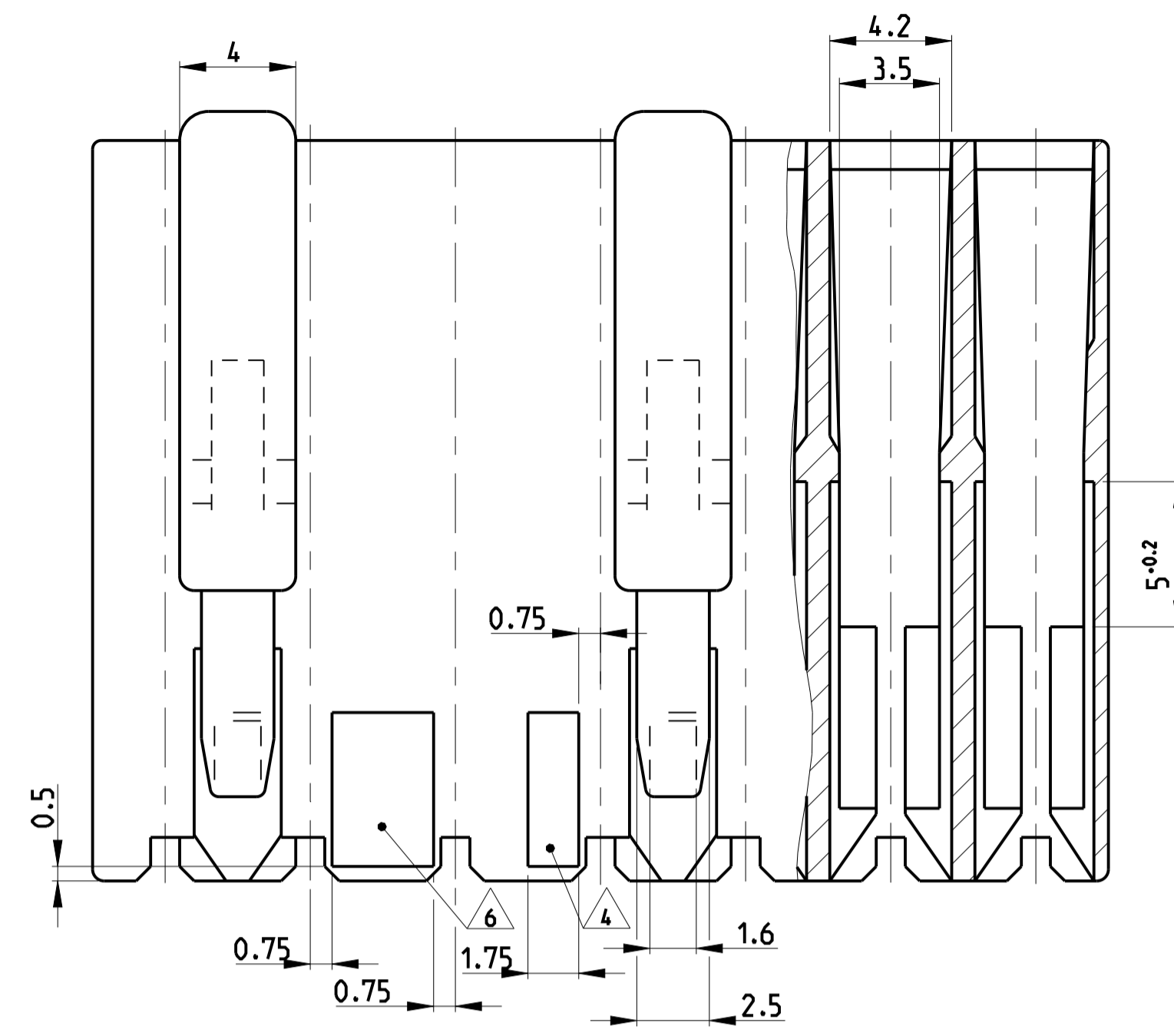
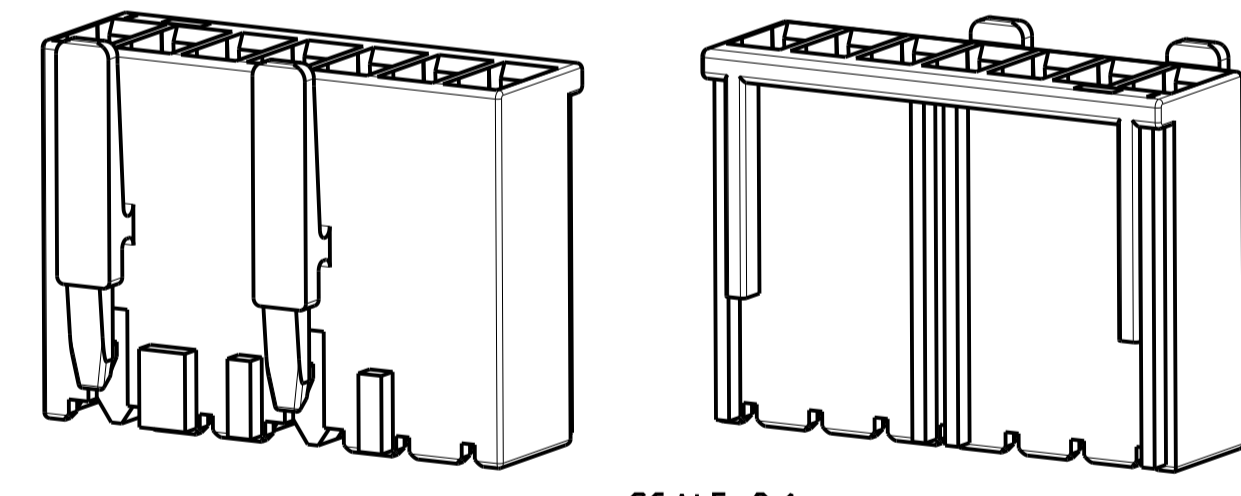
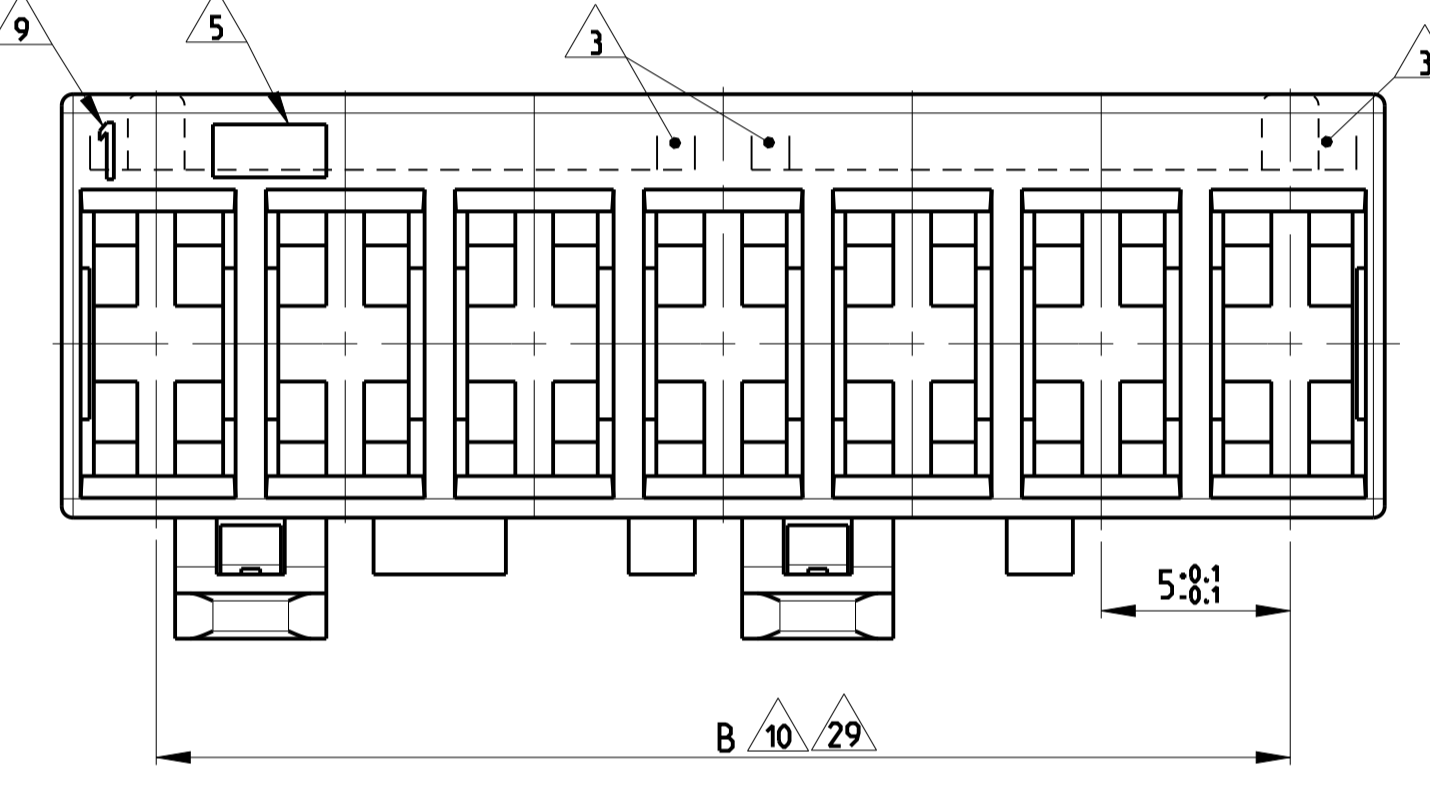
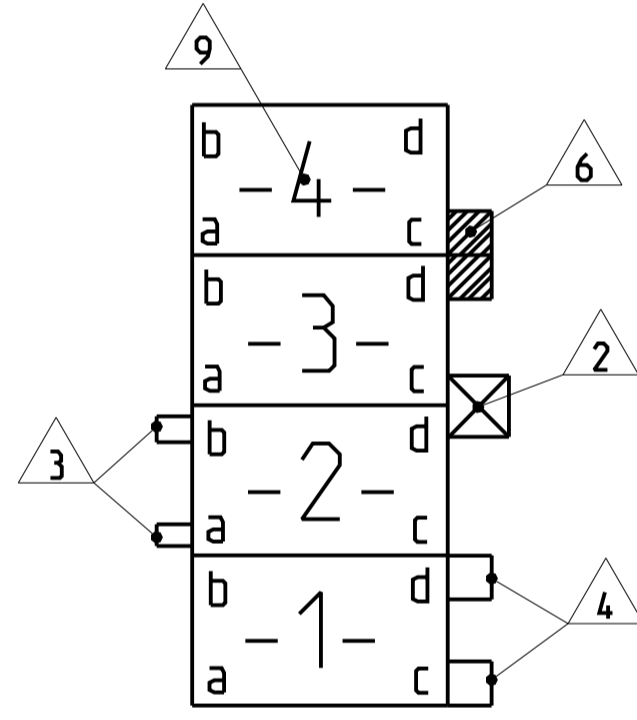
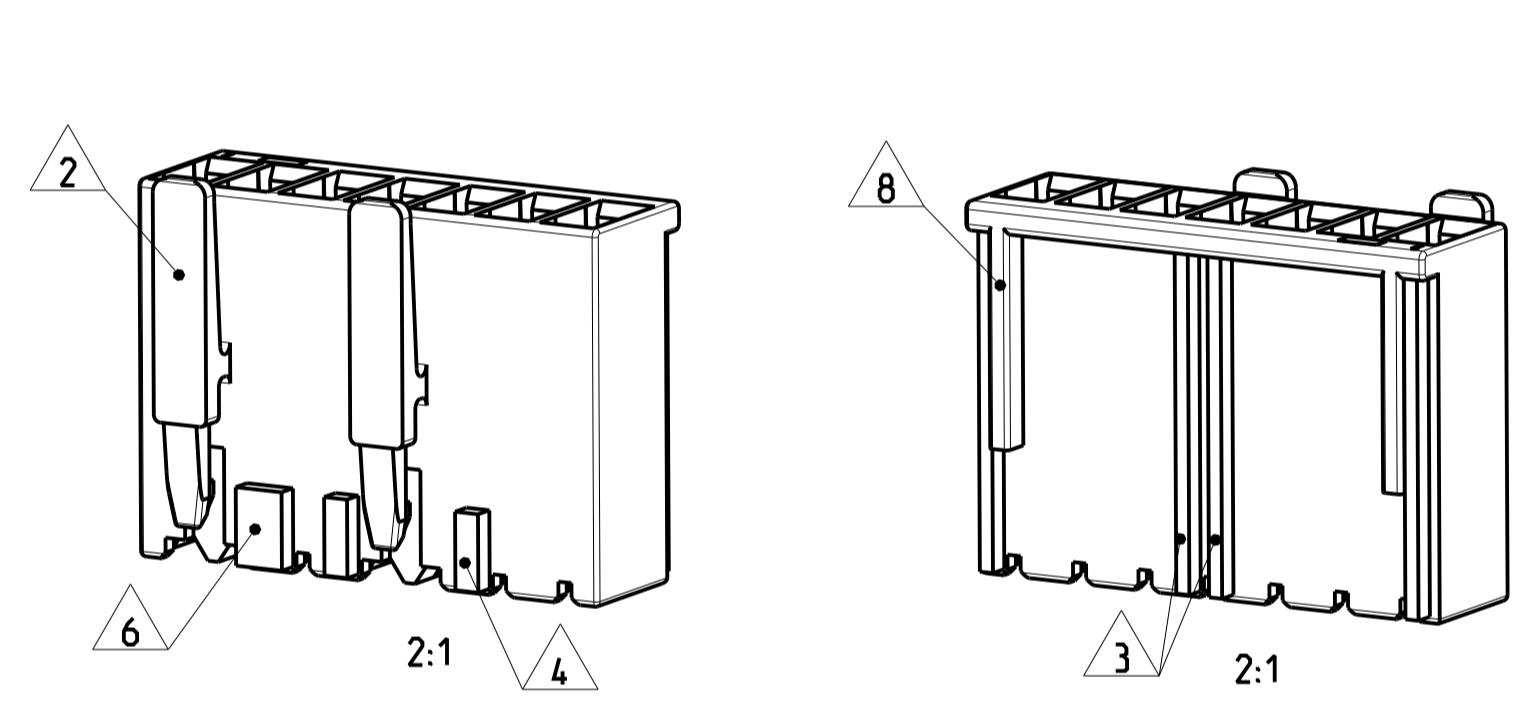

SCALE 2:1

ALL OTHER DIMENSIONS ARE SAME

PAY ATTENTION!
DIFFERENT LOCKING LATCHES

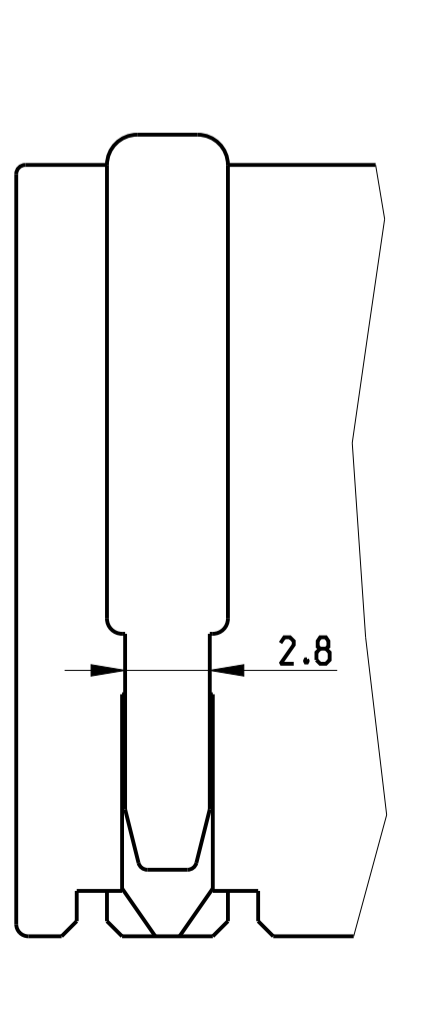
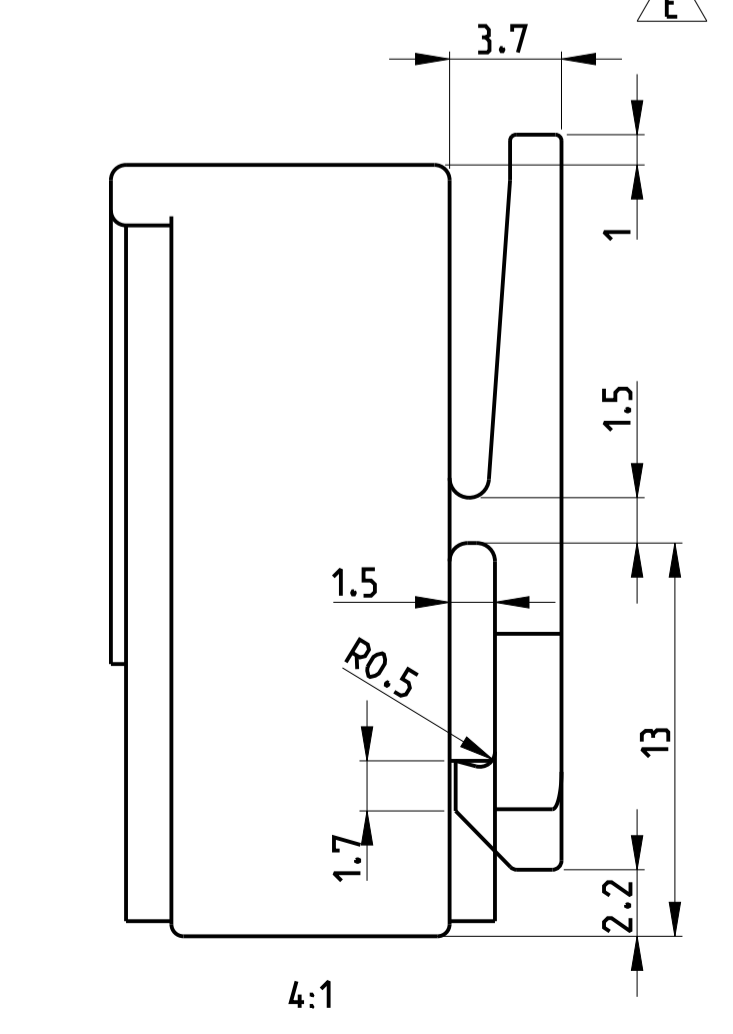
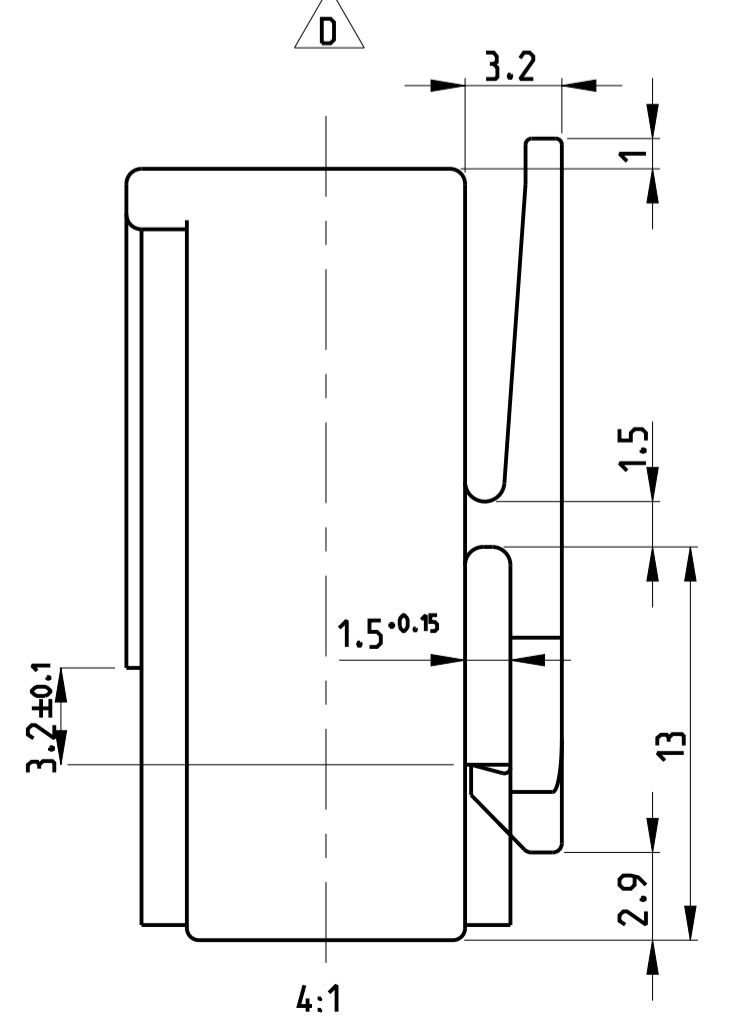
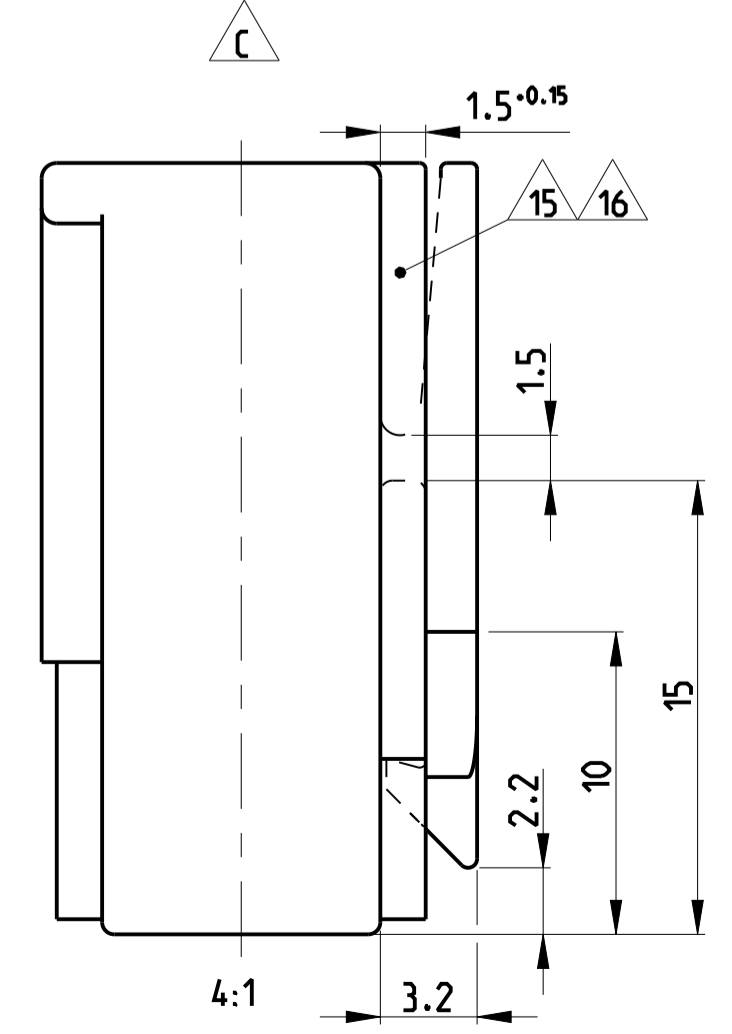
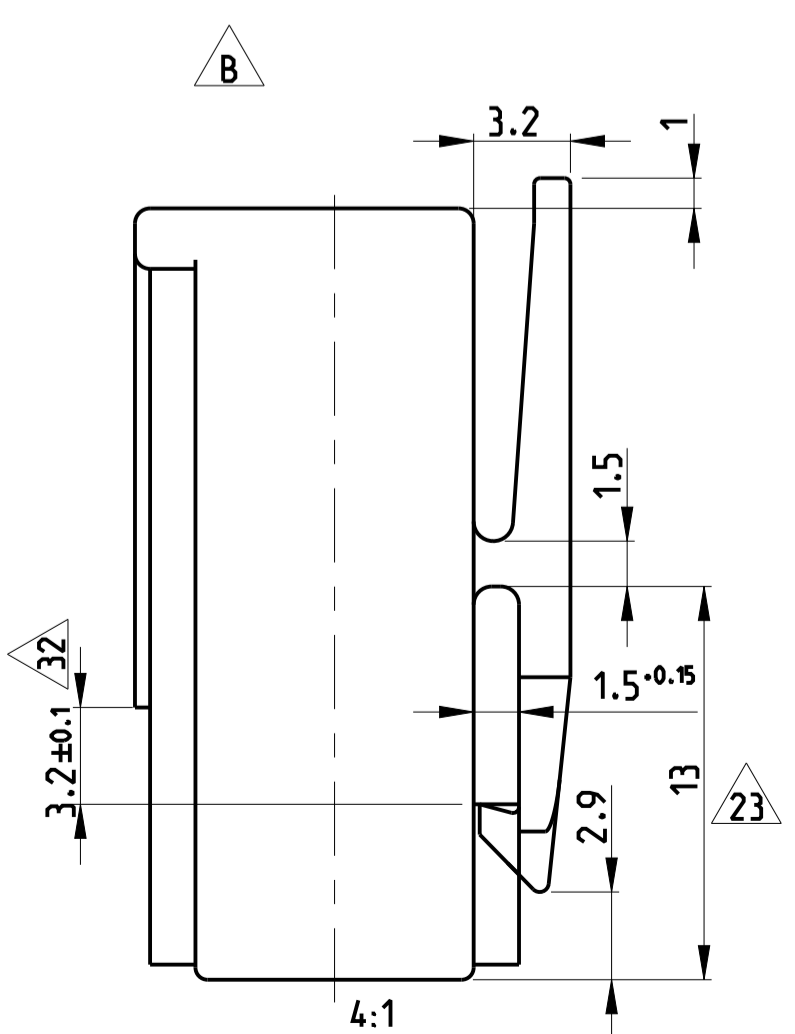
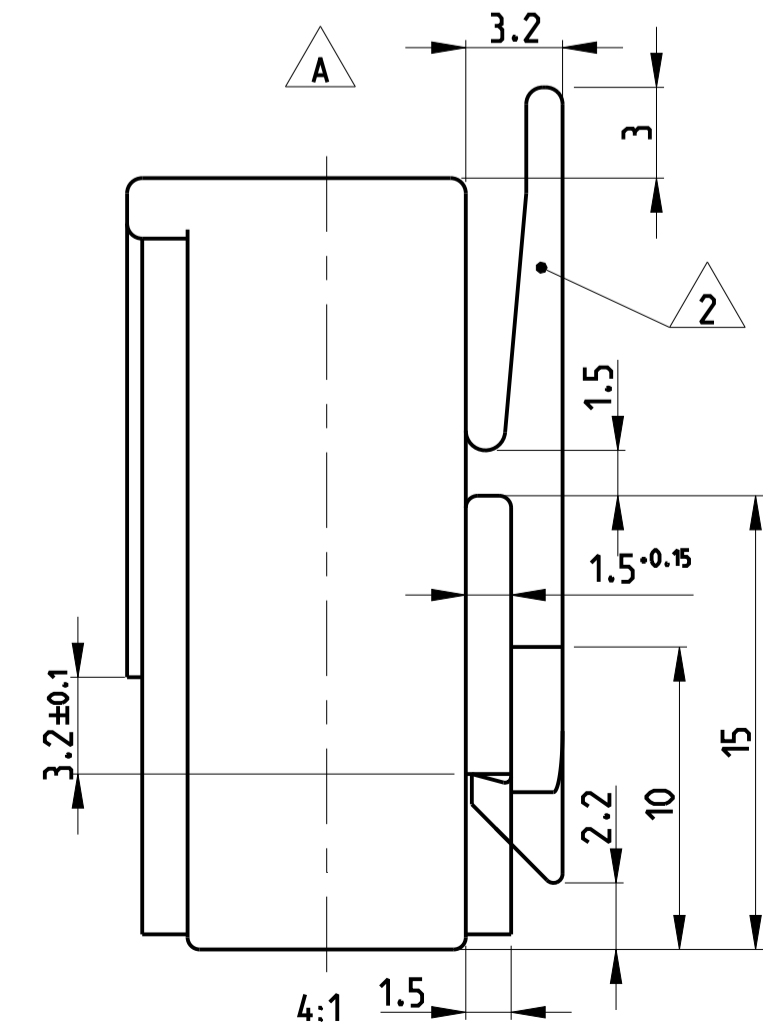

- 1 CAVITY SUITABLE TO STANDARD TIMER CONTACTS LISTED IN PROD: SPEC: 108-18049, ITEM 3.3.2
Kammer geeignet für Standard Timer Kontakte gelistet in Prod. Spec. 108-18049, Punkt 3.3.2
- 2 LOCKING LATCH BETWEEN CAVITY NO. Rasthaken zwischen Kammernummer
- 3 POLARIZATION RIB POSITION "a" OR POSITION "b", AT CAVITY NO..
Polarisierungsrippen (Lage "a") oder (Lage "b") versetzt bei Kammer Nr
- 4 KEYING RIB POSITION "c" OR POSITION "d", AT CAVITY NO..
Kodierungsrippen nach unten (Lage "c") oder oben (Lage "d") versetzt bei Kammernummer
- 5 AREA FOR TE LOGO ACC. TO SPEC 202-36
Bereich für TE Logo nach Spec. 202-36
- 6 WIDTH KEYING RIB BETWEEN CAVITY NO. Breite Kodierrippe zwischen Kammer Nr.
- 7 SUITABLE TO TAB 6.3x0.8mm AND 4.8x0.8mm ACCORDING TO DIN 46244
Geeignet für Flachstecker 6.3x0.8mm und 4.8x0.8mm nach DIN 46244
- 8 MATING STOP BETWEEN CAVITY NO.1 AND 2, ALSO BETWEEN THE LAST AND THE LAST BUT ONE CAVITY
Tiefenanschlag zwischen Kammer Nr.1 und 2, ebenfalls zwischen der letzten und vorletzten Kammer
- 9 CONTACT CAVITY NO. Kammernummer
- 10 DIMENSION A AND DIMENSION B SEE SHEET 2 OF 3
Maß A und Maß B siehe Blatt 2 von 3
- 11 MATED WITH TE CONNECTOR: SEE TABLE, SHEET 2 OF 3
Passender TE Gegenstecker: siehe Tabelle, Seite 2 von 3
- 12 GENERAL SUITABLE TAB HEADER HOUSING SEE RAST 5 PERFORMANCE
Generell passende Flachsteckerwanne, siehe RAST 5 Vorgabe
- 13 CONNECTION TO THE PC BOARD SEE DRAWING 88-9935-4
Leiterplattenanschluß siehe Zeichnung 88-9935-4
- A B SEE TABLE, SHEET 2 OF 3
C D E Siehe Tabelle, Blatt 2 von 3
- 14 MATERIAL CORRESPONDS TO THE REQUIREMENT EN 60335 (INCL. GLOW WIRE TEST 750°C WITHOUT FLAME)
- 15 WIRE TANGLING PROTECTION
- 16 WIRE TANGLING PROTECTION IN COMBINATION WITH CODING RIBS, ONLY VALID FOR VERSIONS 5-964702-3, 0-964702-3, 0-964702-1
- 17 KEYING ACC. TO RAST-5 STANDARD; COLOUR IS DIFFERENT
- 18 8 POS. SPECIAL VERSION WITH SWAGED KEYING RIB
- 19 SPECIAL MATERIAL PA66, UL 94 V0
- 20 DIMENSION "A" IS ACCEPTED WITHIN TOLERANCE +0.05/-0.20.
- 21 PRELIMINARY PART- NOT YET RELEASED FOR PRODUCTION
- 22 ONLY FOR PN 2178600-2, 3-2178600-2, 4-2178600-2, 5-2178600-2, TOLERANCE IS +0.4 -0.2, WORST CASE CAN BE OUT OF RAST STANDARD.
- 23 ONLY FOR PN 2178600-2, 3-2178600-2, 4-2178600-2, 5-2178600-2, TOLERANCE IS +0.4 -0.2
- 24 ONLY FOR PN 2178600-2, 3-2178600-2, 4-2178600-2, 5-2178600-2, TOLERANCE IS ±4°
- 25 ONLY FOR PN 3-1241965-5, 3-1241965-7 TOLERANCE IS +0.3 -0.2
- 26 ONLY FOR PN 3-1241965-5, 3-1241965-7 TOLERANCE IS +0.2 -0.2
- 27 ONLY FOR PN 3-1241965-5, 3-1241965-7 TOLERANCE IS +0.05 -0.2
- 28 OBSOLETE PART
- 29 ONLY FOR 4-1241965-7, 1-2364737-1, TOLERANCE IS -0.3
- 30 ONLY FOR 4-1241965-7, TOLERANCE IS +0.2/-0.25
- 31 ONLY FOR 1-2178029-3, TOLERANCE IS +0.15/-0.2

ADDITIONAL NOTES SEE 3 OF SHEET 4

THIS DRAWING IS A CONTROLLED DOCUMENT.		DWH: Kishor M 18JUL2017		TE Connectivity	
DIMENSIONS: mm		CHK: K. Muntz 07-NOV-06		NAME	
TOLERANCES UNLESS OTHERWISE SPECIFIED:		APPD: Tm Klenner 07-NOV-06		PRODUCT SPEC	
1-PLC ±0.2		108-18049-1		APPLICATION SPEC	
2-PLC ±0.05		SIZE		RESTRICTED TO	
3-PLC ±0.001		CAGE CODE		DRAWING NO	
4-PLC ±0.0001		WEIGHT		A1 00779 C=1241965	
MATERIAL SEE TABLES		FINISH		SHEET 1 OF 4	
		Customer Drawing		SCALE 5:1 REV B51	

KEYING PLAN

LOC		DIST		REVISIONS			
A1	-	P	LTN	DESCRIPTION	DATE	DWN	APVD
				SEE SHEET 1			

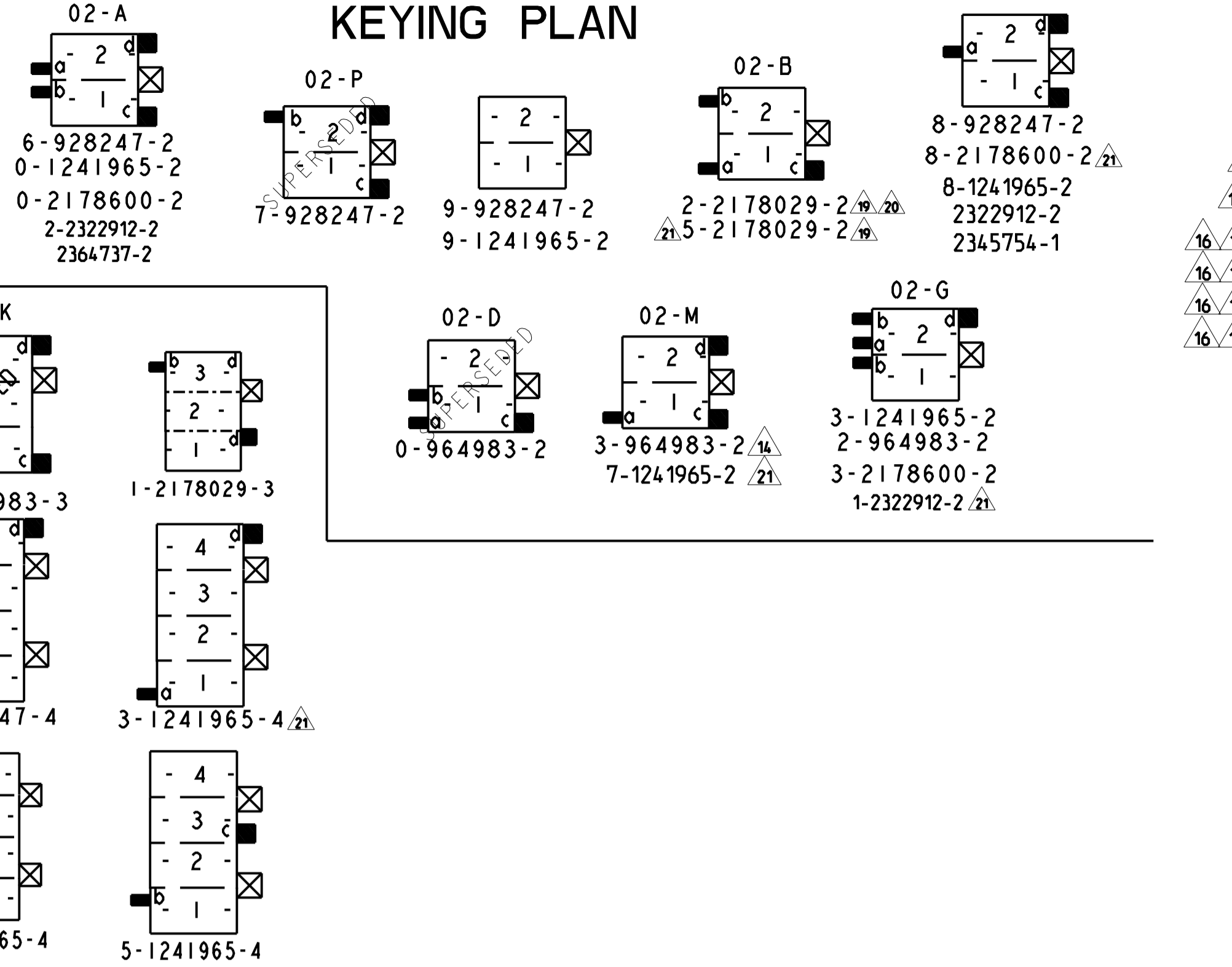
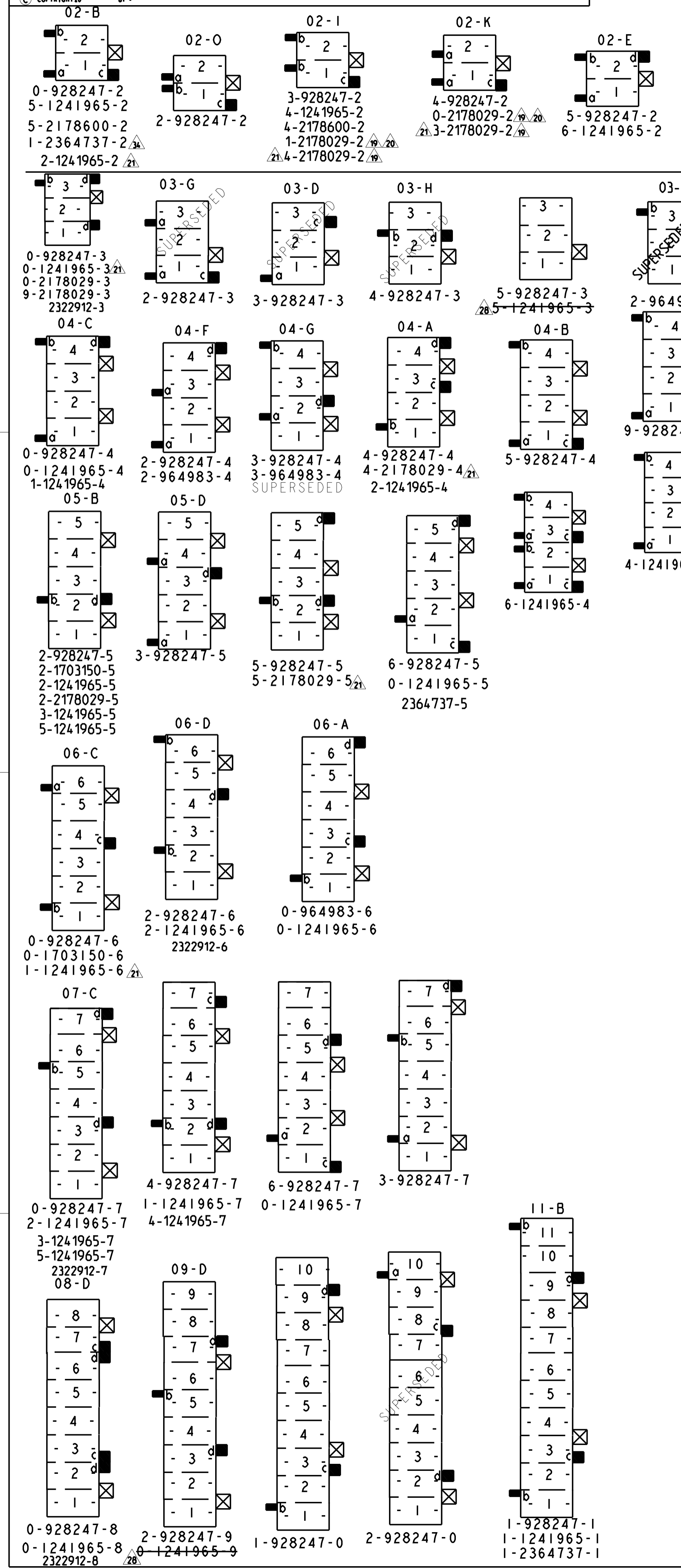

PART NO.	POS.	RAST 5	DIM A	DIM B	COLOUR	MATERIAL	LOCKING LATCH	REV.	MATED WITH
Bestell-Nr.	Pol.	Rast 5	Maß A	Maß B	Farbe	Material	Rasthaken	Rev.	Gegenstecker
3-1241965-7	7	07-C	35	30	NATURAL	PA6 GF15 UL94V-2	D	A	12/13
3-1241965-5	5	05-B	25	20	NATURAL	UL94V-2	D	A	12/13
8-2178600-2	2	02-C	10	5	NATURAL	PA6 GF15 UL94V-2	B	1	12/13
5-2178600-2	2	02-B	10	5	BLACK	UL94V-2	B	B	12/13
4-2178600-2	2	02-I	10	5	RED	UL94V-2	B	B	12/13
3-2178600-2	2	02-G	10	5	BLUE	UL94V-2	B	B	12/13
0-2178600-2	2	02-A	10	5	NATURAL	UL94V-2	B	B	12/13
2-1241965-7	7	07-C	35	30	NATURAL	PA6 UL94V-2	B	A	12/13
1-1241965-6	6	06-C	30	25	NATURAL	UL94V-2	B	1	12/13
0-1241965-6	6	06-A	30	25	NATURAL	UL94V-2	B	A	12/13
5-1241965-3	3	-	15	10	NATURAL	UL94V-2	A	1	12/13
0-1241965-3	3	-	15	10	NATURAL	UL94V-2	B	1	12/13
6-1241965-2	2	02-E	10	5	NATURAL	UL94V-2	B	A	12/13

PART NO.	POS.	RAST 5	DIM A	DIM B	COLOUR	MATERIAL	LOCKING LATCH	REV.	MATED WITH
Bestell-Nr.	Pol.	Rast 5	Maß A	Maß B	Farbe	Material	Rasthaken	Rev.	Gegenstecker
5-2178029-5	5	-	25	20	GREEN	PA66 UL94V-0	B	1	12/13
2-2178029-5	5	-	25	20	BLACK	UL94V-0	B	A	12/13
4-2178029-4	4	-	20	15	NATURAL	UL94V-0	B	1	12/13
9-2178029-3	3	-	15	10	YELLOW	UL94V-0	B	A	12/13
1-2178029-3	3	-	15	10	NATURAL	UL94V-0	B	B	12/13
0-2178029-3	3	-	15	10	NATURAL	UL94V-0	B	A	12/13
5-2178029-2	2	02-B	10	5	NATURAL	UL94V-0	B	1	12/13
4-2178029-2	2	02-I	10	5	NATURAL	UL94V-0	B	1	12/13
3-2178029-2	2	02-K	10	5	NATURAL	UL94V-0	B	1	12/13
2-2178029-2	2	02-B	10	5	BLACK	UL94V-0	B	A	12/13
1-2178029-2	2	02-I	10	5	RED	UL94V-0	B	A	12/13
0-2178029-2	2	02-K	10	5	GREEN	UL94V-0	B	A	12/13

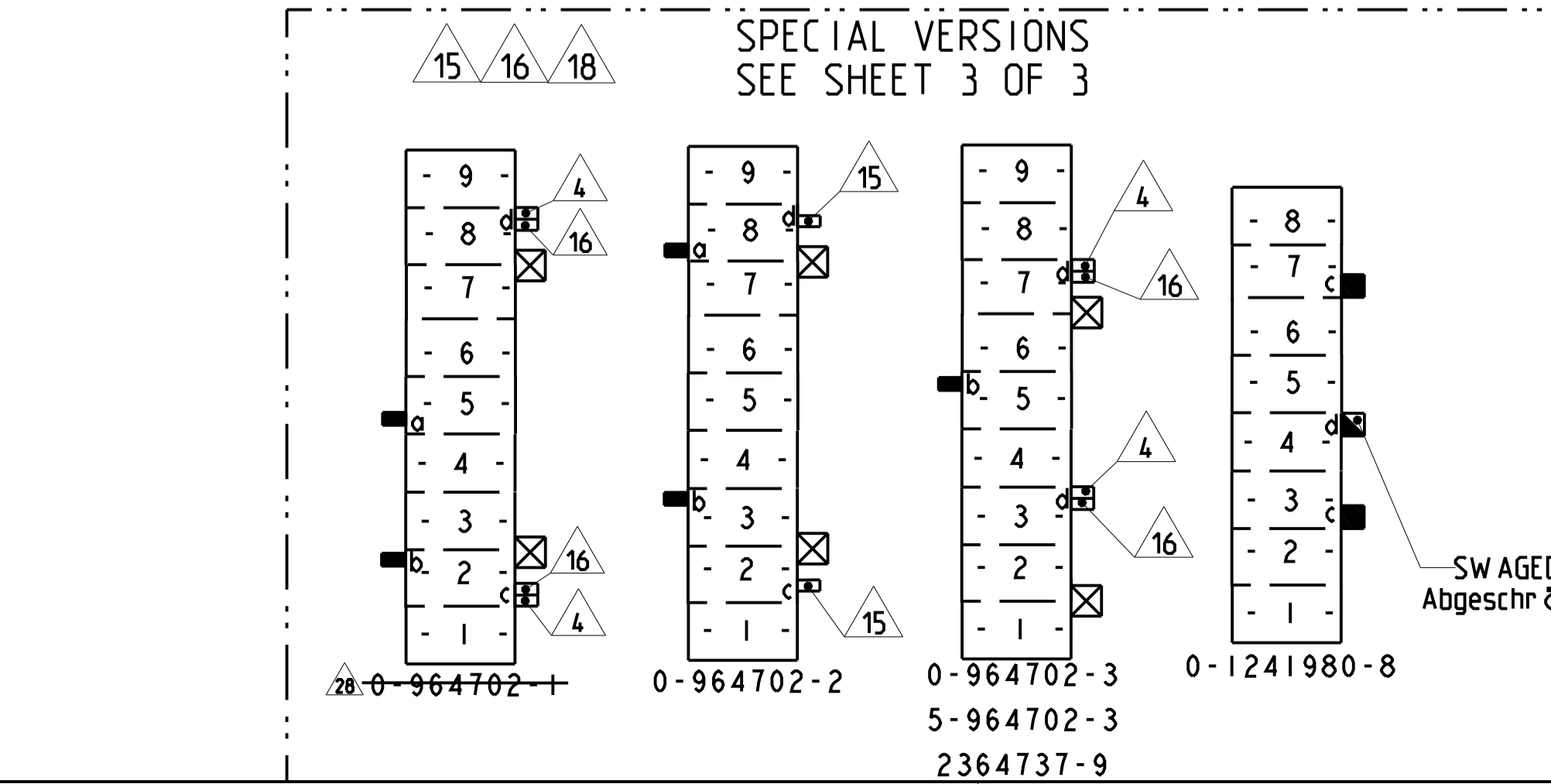

COLOUR	SUPERSEDED BY PN:	PART NO.	POS.	RAST 5	DIM A	DIM B	COLOUR	MATERIAL	LOCKING LATCH	REV.	MATED WITH
Farbe	Bestell-Nr.	Pol.	Rast 5	Maß A	Maß B	Farbe	Material	Rasthaken	Rev.	Gegenstecker	
NATURE	1-969484-7	3	03-H	15	10	BROWN/braun	UL94V-2	B	A	12/13	
NATURE	1-969484-8	3	03-D	15	10	BLUE/blau	UL94V-2	A	A	12/13	
NATURE	3-969484-7	2	02-B	10	5	VIOLET/violett (lila)	UL94V-2	A	A	12/13	
		0-928247-3	3	-	15	YELLOW/gelb	UL94V-2	B	B	12/13	
		9-928247-2	2	-	10	NATURE/natur	UL94V-2	B	B	12/13	
		8-928247-2	2	02-C	10	GREY/grau	UL94V-2	B	B	12/13	
NATURE	0-969484-3	7	02-P	10	5	PURPLED/purpurröt	UL94V-2	A	A	12/13	
		6-928247-2	2	02-A	10	NATURE/natur	UL94V-2	B	B	12/13	
		5-928247-2	2	02-E	10	GREEN/grün	UL94V-2	B	B	12/13	
		4-928247-2	2	02-K	10	YELLOW GREEN/gelbgrün	UL94V-2	B	B	12/13	
		3-928247-2	2	02-I	10	ORANGE/orange	UL94V-2	A	A	12/13	
		2-928247-2	2	02-O	10	PINK/rosa	UL94V-2	A	A	12/13	
		0-928247-2	2	02-B	10	BLACK/schwarz	UL94V-2	B	B	12/13	

THIS DRAWING IS A CONTROLLED DOCUMENT. DIMENSIONS: mm. TOLERANCES UNLESS OTHERWISE SPECIFIED: ±0.2. MATERIAL: SEE TABLES. FINISH: -.

DATE: 18 JUL 2017. CHK: K. Munz. APPVD: T. Klenner. PRODUCT SPEC: 108-18049. APPLICATION SPEC: -.

Customer Drawing. SCALE: 5:1. SHEET 2 OF 4. REV B51.

LOC	DIST	REV	DATE	BY	APPROV
A1	-				

REVISIONS					
NO	DATE	DESCRIPTION	BY	CHKD	APPROV
		SEE SHEET 1			

- △32 ONLY FOR 2322912-3. TOLERANCE IS +0.1/-0.15
- △33 ONLY FOR 2322912-6. 1-2364737-1. TOLERANCE IS -0.30
- △34 CANDIDATE PRELIMINARY P/N. NOT YET OFFICIAL. ONLY FOR DISCUSSION. NOT YET RELEASED FOR PRODUCTION.
- △35 DOUBLE SOURCE RESIN: ALTERNATIVE RESIN UNDER APPROVAL.

	5-1241965-5	5	05-B	25	20	NATURAL	UL94-V0 & GW EPT 750 no flame	E	B	△12 △13
△32	1-2364737-2	2	02-B	10	5	BLUE		B	2	△12 △13
△33	2364737-9	9	-	45	40	BLUE		C	B	△12 △13
	1-2364737-1	11	11-B	55	50	BLUE		B	B	△12 △13
	2364737-5	5	-	25	20	BLUE		B	B	△12 △13
	2364737-2	2	02-A	10	5	BLUE	△34 △35	B	B	△12 △13
	2322912-8	8	08-D	40	35	BLUE	PA66 UL94 V0 GW T 750	B	B	△12 △13
	2322912-7	7	07-C	35	30	GREY		B	B	△12 △13
	2322912-6	6	06-D	30	25	BLUE		B	B	△12 △13
	2322912-3	3	-	15	10	YELLOW		B	B	△12 △13
	2-2322912-2	2	02-A	10	5	NATURE		B	B	△12 △13
△32	1-2322912-2	2	02-G	10	5	BLUE		B	1	△12 △13
	2322912-2	2	02-C	10	5	GREY	B	B	△12 △13	
△32	2-1241965-2	2	-	10	5	NATURAL	PA66 UL94 V0 GW T 750 CTI350	E	1	△12 △13
	5-1241965-4	4	-	20	15	NATURAL		E	B	△12 △13
	4-1241965-4	4	-	20	15	NATURAL		E	B	△12 △13
△32	3-1241965-4	4	-	20	15	NATURAL		E	1	△12 △13
	2-1241965-4	4	-	20	15	NATURAL		E	A	△12 △13
	1-1241965-4	4	04-C	20	15	NATURAL		E	A	△12 △13
	8-1241965-2	2	02-C	10	5	NATURAL		E	A	△12 △13
	4-1241965-7	7	-	35	30	NATURAL		E	A	△12 △13
	5-1241965-7	7	07-C	35	30	NATURAL		E	B	△12 △13
△32	5-1241965-5	5	05-B	25	20	NATURAL		E	1	△12 △13
	PART NO.	POS.	RAST 5	DIM A	DIM B	COLOUR	MATERIAL	LOCKING LATCH	REV.	MATED WITH
SPECIAL VERSION: UL94 V0 & GW T 750										

2345754-1	2	02-C	10	5	NATURAL	PA66 UL94 V0	E	B	△12 △13
PART NO.	POS.	RAST 5	DIM A	DIM B	COLOUR	MATERIAL	LOCKING LATCH	REV.	MATED WITH
SPECIAL VERSION: UL94 V0									

KEYING PLAN SEE SHEET 2 OF 4

THIS DRAWING IS A CONTROLLED DOCUMENT.		DATE: 18 JUL 2017	 TE Connectivity
DIMENSIONS: mm		DWG: Kishor M CHK: K. Munz APD: Tn. Klennner	
TOLERANCES UNLESS OTHERWISE SPECIFIED: 0 PLC ± 1 PLC ±0.1 2 PLC ±0.01 3 PLC ±0.001 4 PLC ±0.0001 ANGLES FINISH *		07-NOV-06 07-NOV-06 NAME: Tn. Klennner PRODUCT SPEC: 108-18049 APPLICATION SPEC:	2-12 POS. STANDARD TIMER HSG WITH EXTERIOR LOCKING SIZE: A1 CAGE CODE: 1241965 DRAWING NO: 00779
MATERIAL SEE TABLES		WEIGHT: -	RESTRICTED TO: -
		Customer Drawing	SCALE: 5:1 SHEET 3 OF 4

SPECIAL VERSIONS 15 16
9 POS STD. TIMER HSG. WITH TANGLING PROTECTION

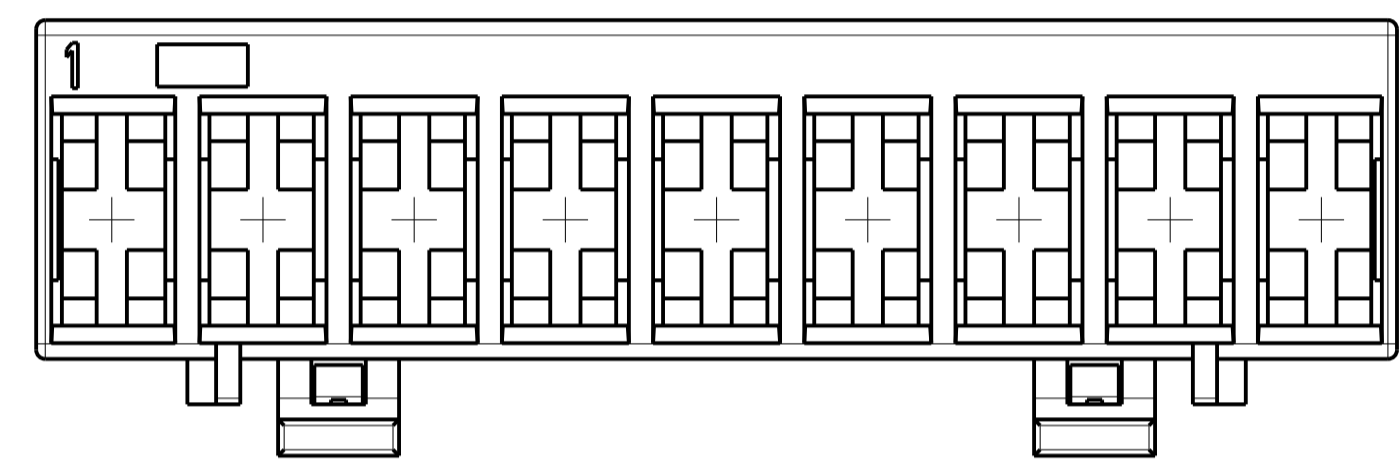
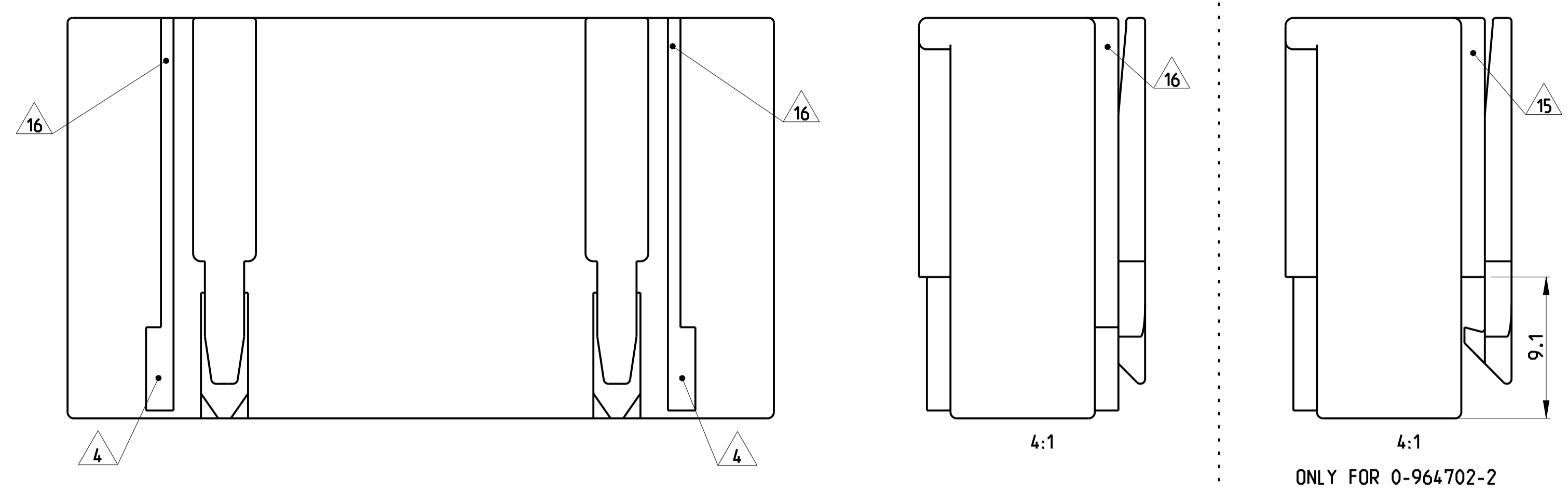

SPECIAL VERSION 18
8 POS SPECIAL STD. TIMER HSG.

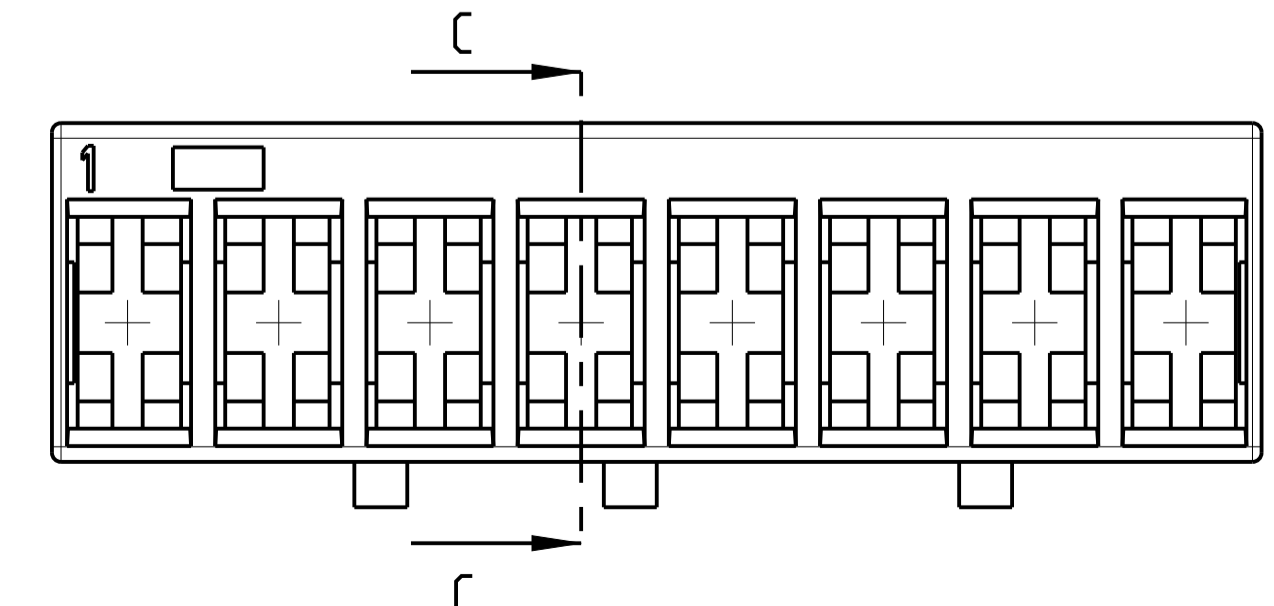
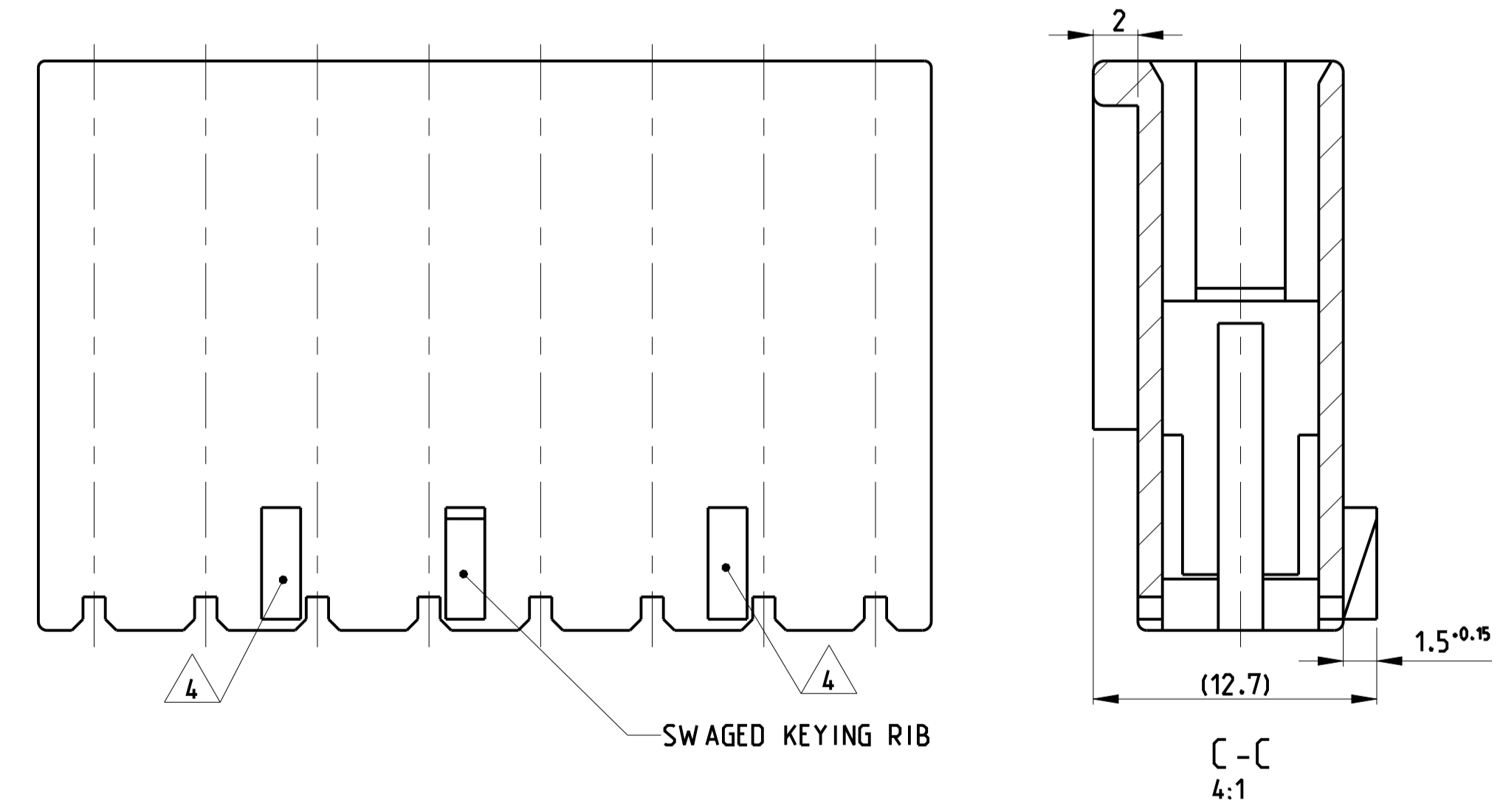

LOC	DIST	REV	DESCRIPTION	DATE	DRW	APPD
A1	-	-	SEE SHEET 1	-	-	-

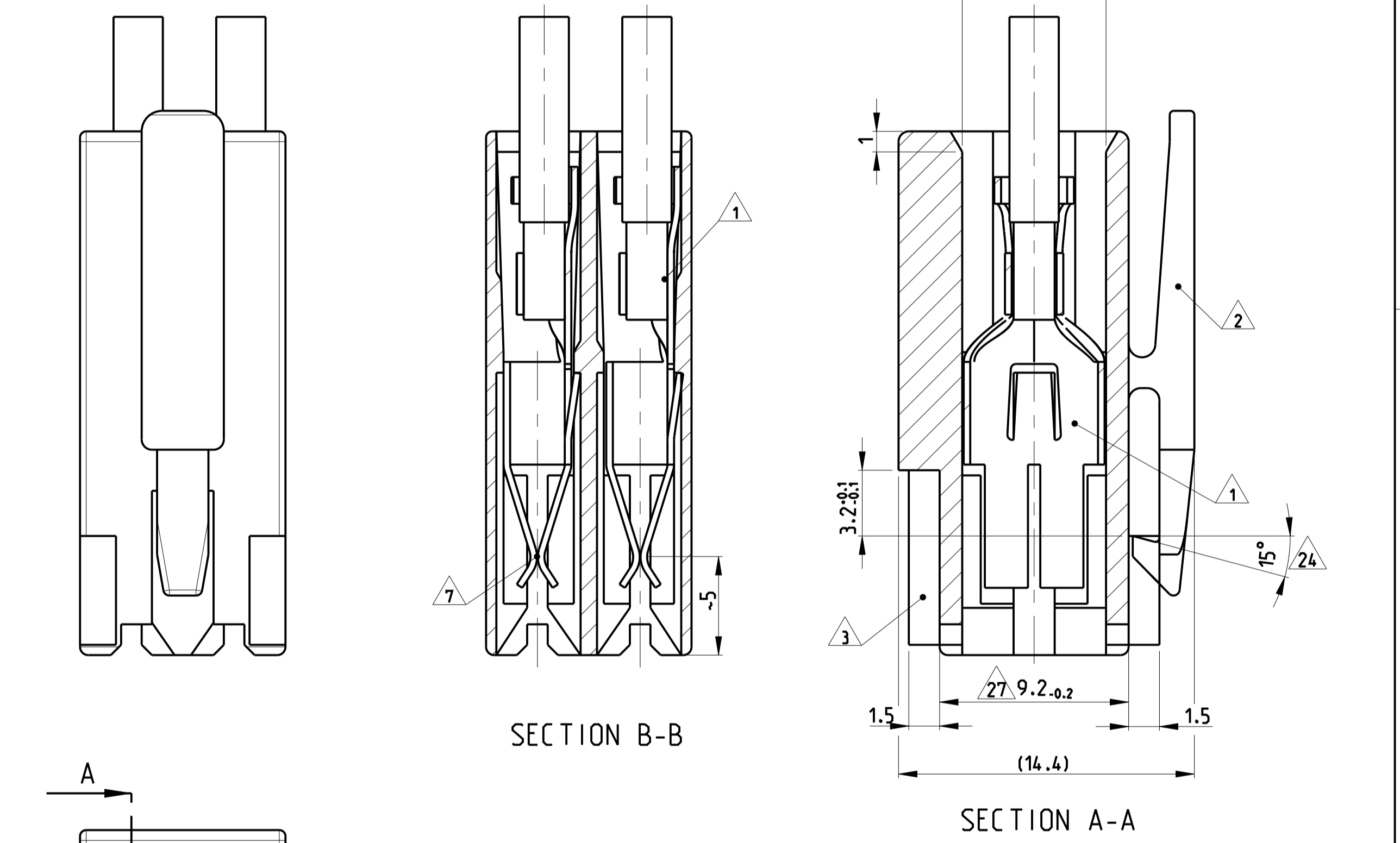
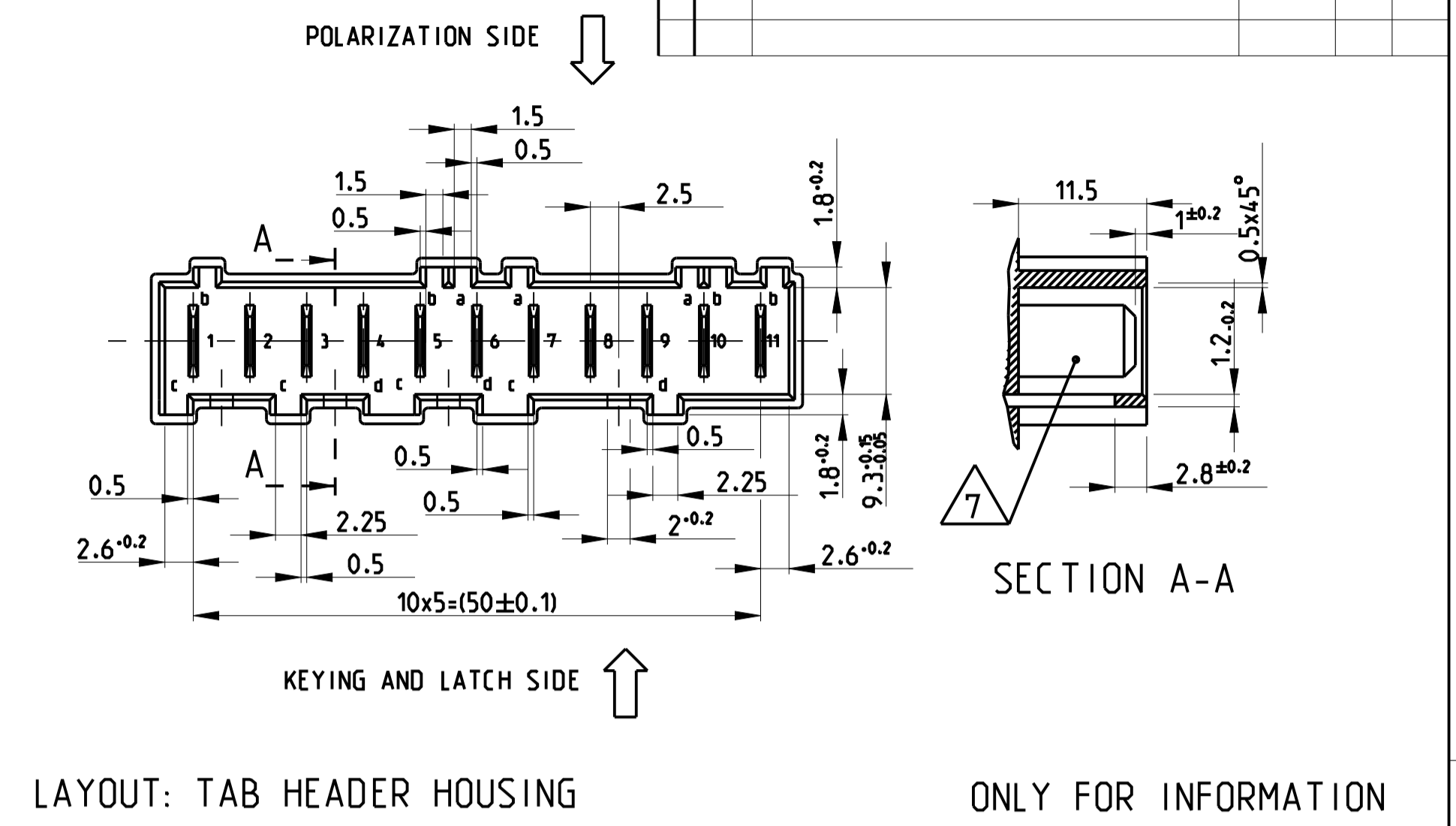

THIS DRAWING IS A CONTROLLED DOCUMENT.		DRW: Kishor M 18 JUL 2017	TE Connectivity
DIMENSIONS: mm		CHK: K. Muntz 07-NOV-06	
TOLERANCES UNLESS OTHERWISE SPECIFIED: ±0.2		APPD: Th. Klenner 07-NOV-06	NAME
0-PLC ±0.1 1-PLC ±0.1 2-PLC ±0.05 3-PLC ±0.001 4-PLC ±0.0001		PRODUCT SPEC	2-12 POS. STANDARD TIMER HSG WITH EXTERIOR LOCKING
MATERIAL SEE TABLES		FINISH	SIZE: CAGE CODE DRAWING NO. RESTRICTED TO
		WEIGHT	A1 00779 C=1241965
		Customer Drawing	SCALE: 5:1 SHEET 4 OF 4 REV B51

X-ON Electronics

Largest Supplier of Electrical and Electronic Components

Click to view similar products for [Automotive Connectors](#) category:

Click to view products by [TE Connectivity](#) manufacturer:

Other Similar products are found below :

[003-018-000](#) [600858](#) [60403001](#) [60993906-B](#) [60993913-B](#) [629515004020001](#) [M83723/71R1808N L/C](#) [M902-2131](#) [M902-2161](#) [M902-2344](#)
[72.330.1035.1](#) [73.353.4028.0](#) [F118010](#) [F119300-B](#) [F132210](#) [F166900](#) [F180100](#) [F258300](#) [F258300-B](#) [F294300-B](#) [F339100](#) [F339700](#)
[F358300-B](#) [F374110](#) [F407400](#) [F412210](#) [F444110](#) [F487000](#) [F495100](#) [F500900-B](#) [F509500B-B](#) [770444-1](#) [827153-1](#) [881735-1](#)
[8N1515-32-24P](#) [9-1326729-8](#) [925467-1](#) [925474-1](#) [928905-1](#) [936398-2](#) [964562-4](#) [964731-2](#) [968782-1](#) [GT17SA-8DS-HU](#) [GT17VS-10DP-](#)
[5.2CF](#) [98315-0001](#) [98315-0010](#) [98891-1012](#) [98895-2014](#) [98936-1039](#)