

LOC	DIST	REVISIONS					
		P	LTN	DESCRIPTION	DATE	DWN	APVD
GP	00						
		C1		REVISED PER ECO-11-004835	11MAR2011	RK	HMR
		D		REVISED PER ECO-12-005533	31MAR2012	JY	AC
		E		REVISED PER ECO-13-009872	26NOV2013	RG	MC
		F		REVISED PER ECO-14-016878	30EC2014	RG	MC

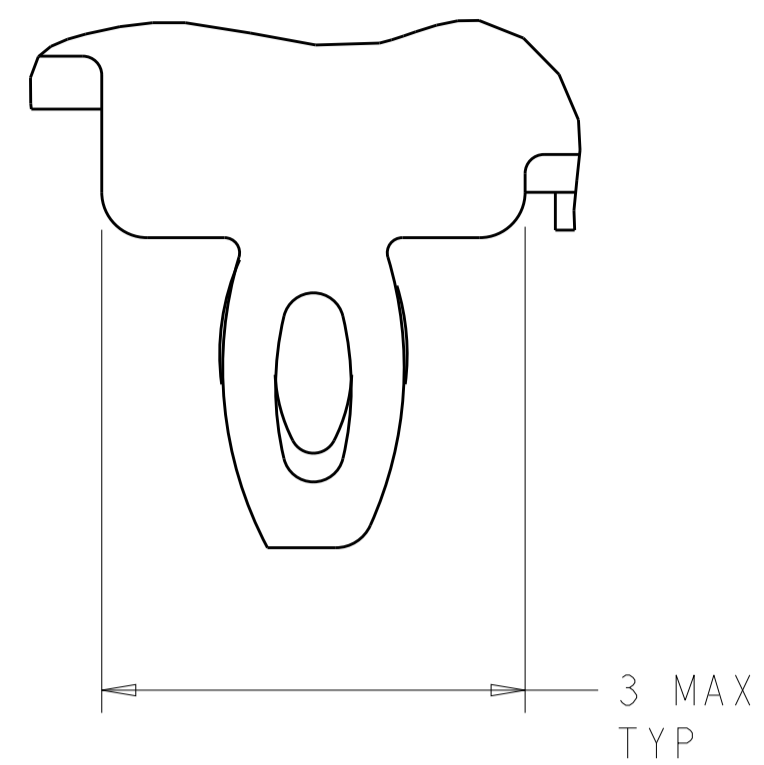

DETAIL S  $\Delta 12$   
 SCALE 20:1

- $\Delta 1$  CAGE ASSEMBLY MATERIAL: NICKEL SILVER, 0.25 THICK  
 HEAT SINK MATERIAL: ALUMINUM  
 HEAT SINK CLIP MATERIAL: STAINLESS STEEL  
 EMI SPRINGS MATERIAL: COPPER ALLOY  
 FRONT FLANGE MATERIAL: ZINC ALLOY  
 LIGHT PIPE MATERIAL: CLEAR POLYCARBONATE
- $\Delta 2$  PITCH BETWEEN PORTS OF ONE 1X3 CAGE ASSEMBLY.
- $\Delta 3$  SPACING BETWEEN CAGES ON THE SAME PC BOARD, TO BE SPECIFIED BY CUSTOMER, MUST COMPLY WITH MINIMUM DIMENSIONS SHOWN.
- $\Delta 4$  REFERENCE APPLICATION SPEC 114-13218 FOR RECOMMENDED DRILL HOLE DIAMETER AND PLATING THICKNESS.
- $\Delta 5$  DATUMS AND BASIC DIMENSIONS ESTABLISHED BY CUSTOMER.
- $\Delta 6$  DIMENSION F IS THE NOMINAL THICKNESS OF CUSTOMER SUPPLIED PC BOARD, SINGLE SIDED PC BOARD MINIMUM THICKNESS = 1.45mm, DOUBLE SIDED PC BOARD MINIMUM THICKNESS = 2.2mm PER QSFP
- $\Delta 7$  HEAT SINKS, LIGHT PIPES, AND HEAT SINK CLIPS SHIPPED ASSEMBLED TO CAGE ASSEMBLY. CAGE ASSEMBLY MAY BE PRESSED INTO THE PCB AS SHIPPED.
- $\Delta 8$  DATUM -A- IS TOP SURFACE OF PC BOARD.
- $\Delta 9$  DIMENSION APPLIES WITH MODULE INSERTED IN CAGE.
- $\Delta 10$  UNPLATED THRU HOLE.
- 11. MATES WITH QSFP MSA COMPATIBLE TRANSCEIVER.
- $\Delta 12$  SURFACE TRACES PERMITTED WITHIN THIS AREA EXCEPT WHERE CAGE STANDOFFS, SHOWN IN DETAIL S, CONTACT PC BOARD.
- $\Delta 13$  BASELINE FOR THESE DIMENSIONS IS THE CENTER OF COMPLIANT PIN HOLE.
- $\Delta 14$  2D BARCODE AND DATE CODE (YYWWD) MARKED ON SIDE OF CAGE ASSEMBLY.

- $\Delta 15$  REFERENCE APP SPEC 114-13218 FOR GASKET THICKNESS CALCULATION.
- $\Delta 16$  EMI SPRING FINISH: 2 $\mu$ m MIN TIN  
 FRONT FLANGE FINISH: 3 $\mu$ m MIN TIN OVER 1.27 $\mu$ m MIN NICKEL OVER 5.08 $\mu$ m MIN COPPER.  
 HEAT SINK FINISH: BLACK ANODIZED.
- $\Delta 17$  HEAT SINKS AND CLIPS SHIPPED ASSEMBLED TO CAGE ASSEMBLY. CAGE ASSEMBLY MAY BE PRESSED IN TO THE PCB AS SHIPPED. LIGHT PIPES, SHIPPED UNATTACHED, MUST BE ASSEMBLED BY CUSTOMER AFTER THE CAGE IS SEATED IN THE PCB.

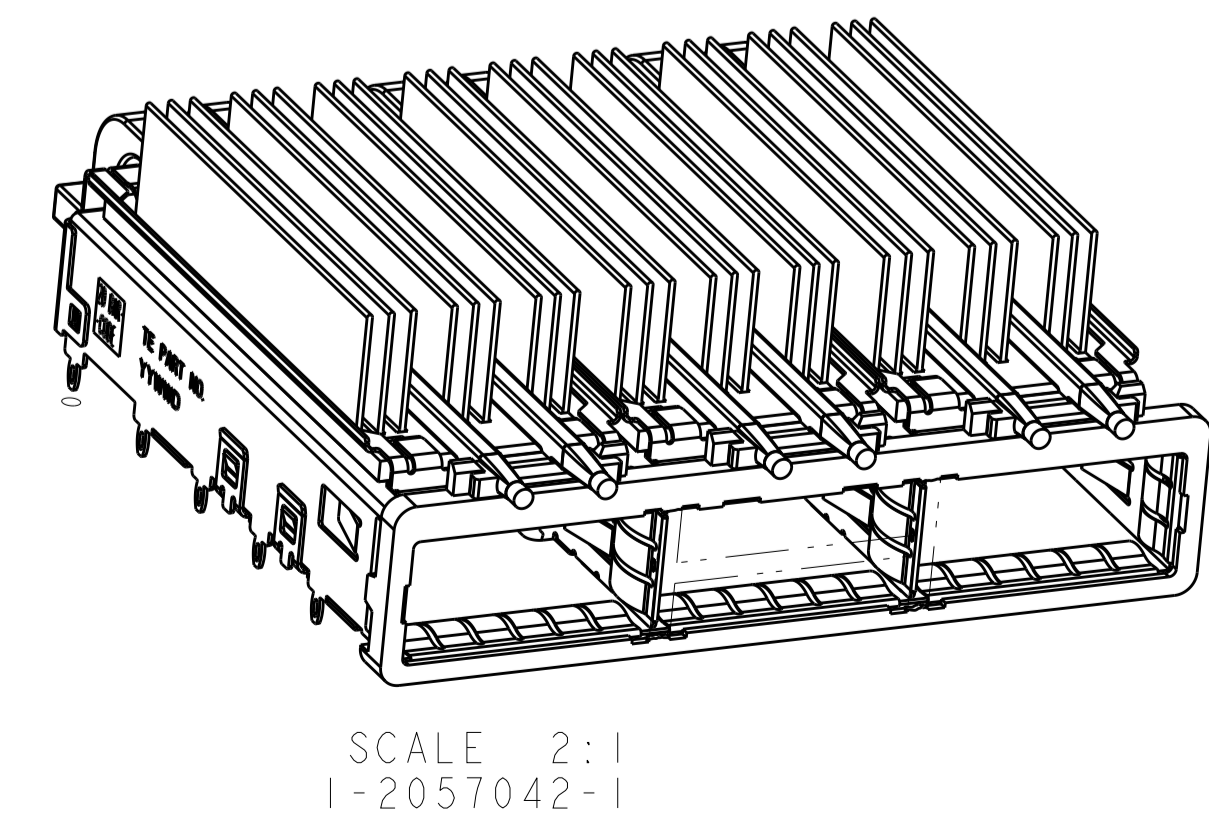
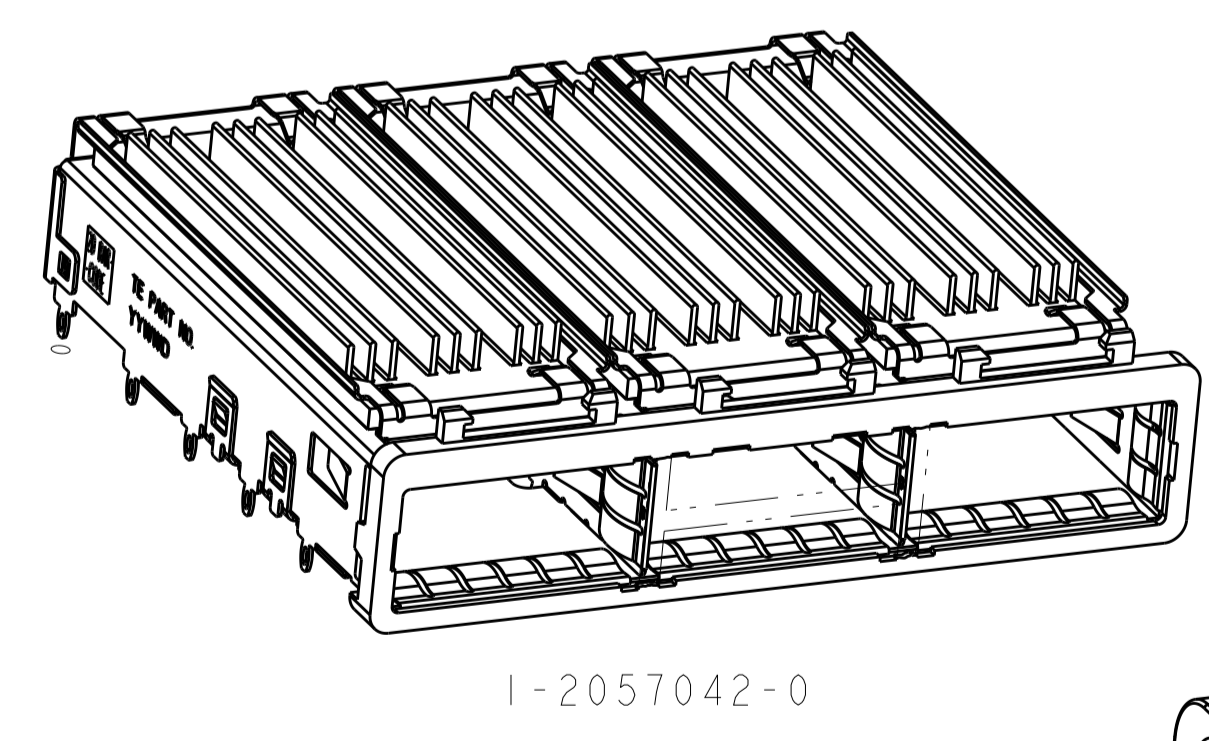
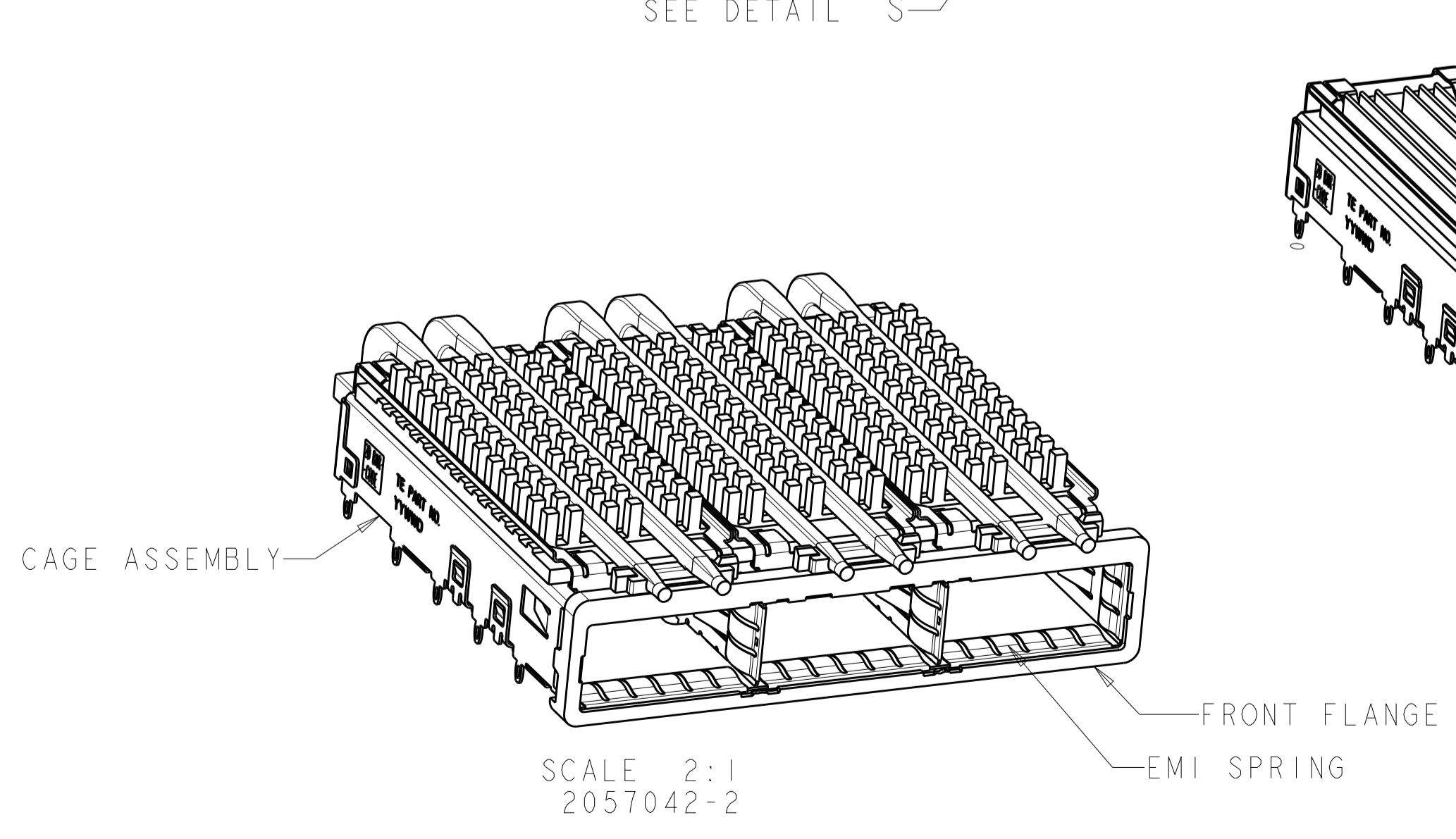
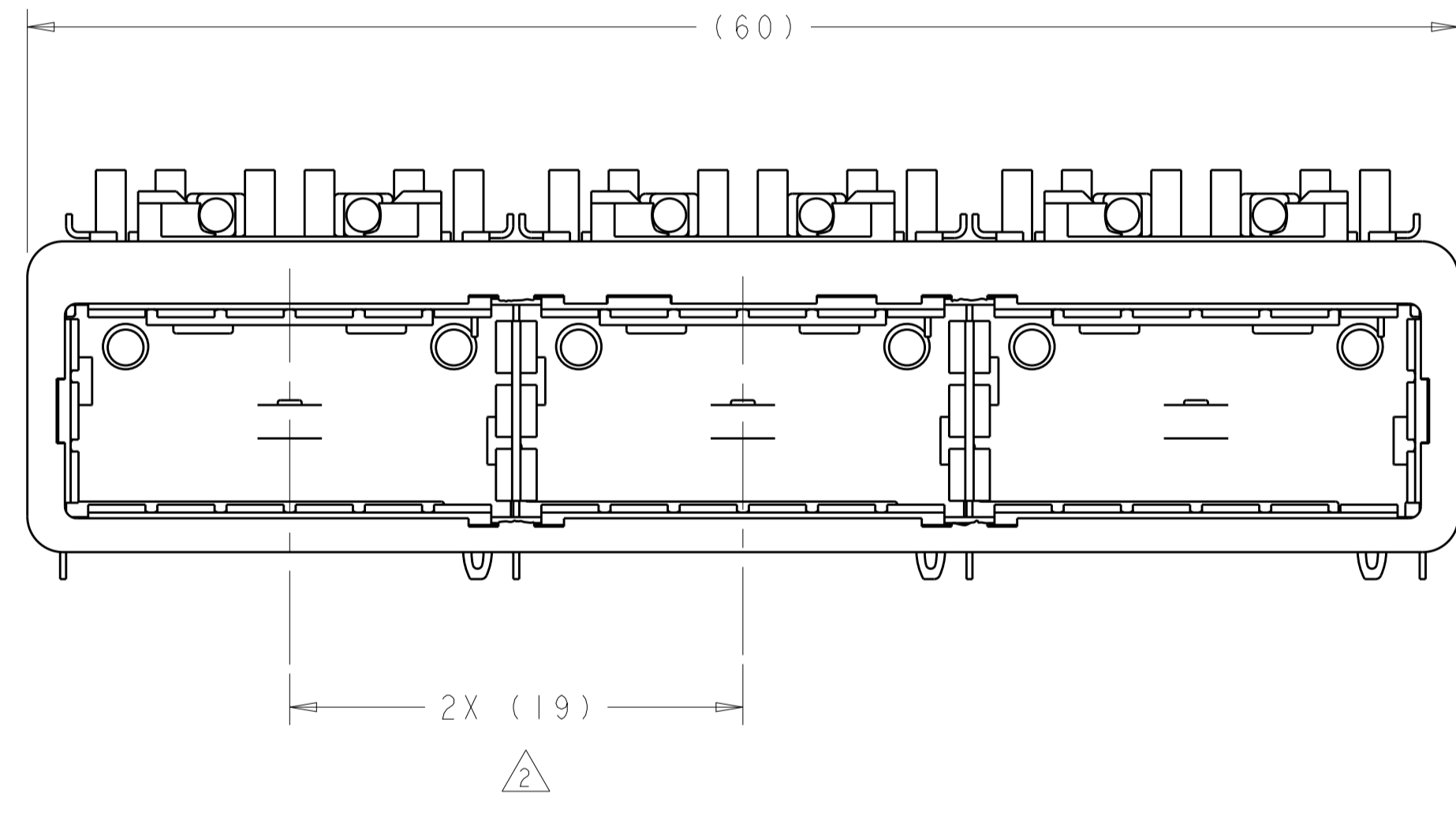
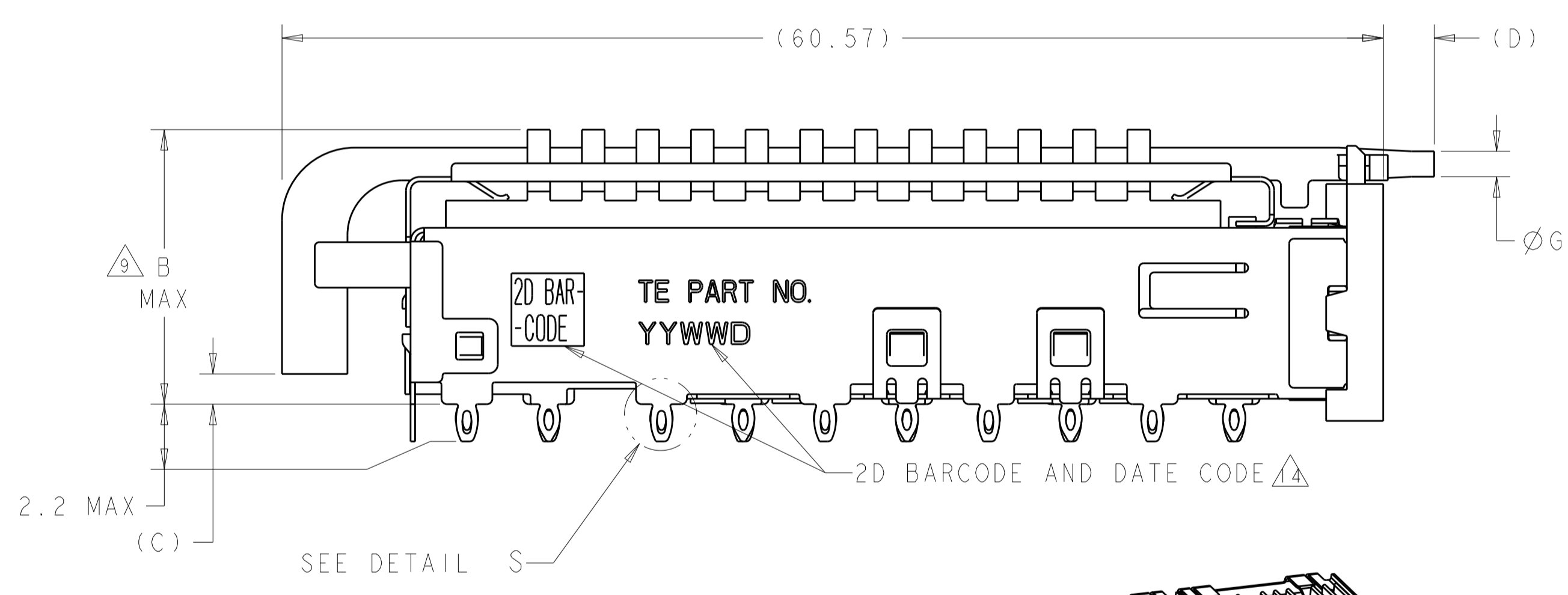

$\Delta 1$	1.4	0.8-1.1	2.0	1.70	21.0	FIN TYPE	1-2057042-1
	N/A	N/A	N/A	N/A	15.0	FIN TYPE	1-2057042-0
$\Delta 1$	2.0	0.8-1.1	3.5	1.70	16.8	CUSTOMERIZED	2057042-9
$\Delta 1$	1.4	0.8-1.1	2.0	1.70	23.0	NETWORKING	2057042-8
$\Delta 1$	1.4	0.8-1.1	2.0	1.70	16.0	SAN	2057042-7
$\Delta 17$	1.4	0.8-1.1	2.0	1.70	13.7	PCI	2057042-6
$\Delta 1$	1.4	1.3-1.4	5.7	2.15	16.0	SAN	2057042-5
$\Delta 17$	1.4	1.3-1.4	5.7	2.15	13.7	PCI	2057042-4
$\Delta 1$	1.4	0.8-1.1	2.8	1.70	23.0	NETWORKING	2057042-3
$\Delta 1$	1.4	0.8-1.1	2.8	1.70	16.0	SAN	2057042-2
$\Delta 17$	1.4	0.8-1.1	2.8	1.70	13.7	PCI	2057042-1
	G	E	D	C	B	HEAT SINK PROFILE	PART NUMBER

THIS DRAWING IS A CONTROLLED DOCUMENT. DWN: C. VALENTINI 28FEB2008  
 CHK: E. BRIGHT 28FEB2008  
 APVD: E. BRIGHT 28FEB2008

TE Connectivity

NAME: 1X3 CAGE ASSEMBLY, BEHIND BEZEL, W/ LIGHT PIPES AND HEAT SINKS, QSFP

PRODUCT SPEC: 108-2286  
 APPLICATION SPEC: 114-13218

SIZE: A1 CAGE CODE: 00779 DRAWING NO: 2057042  
 WEIGHT: -

CUSTOMER DRAWING

SCALE: 4:1 SHEET 1 OF 5 REV F

LOC	DIST	REVISIONS					
GP	00	P.	LYR	DESCRIPTION	DATE	DWN	APVD
		-		SEE SHEET 1			

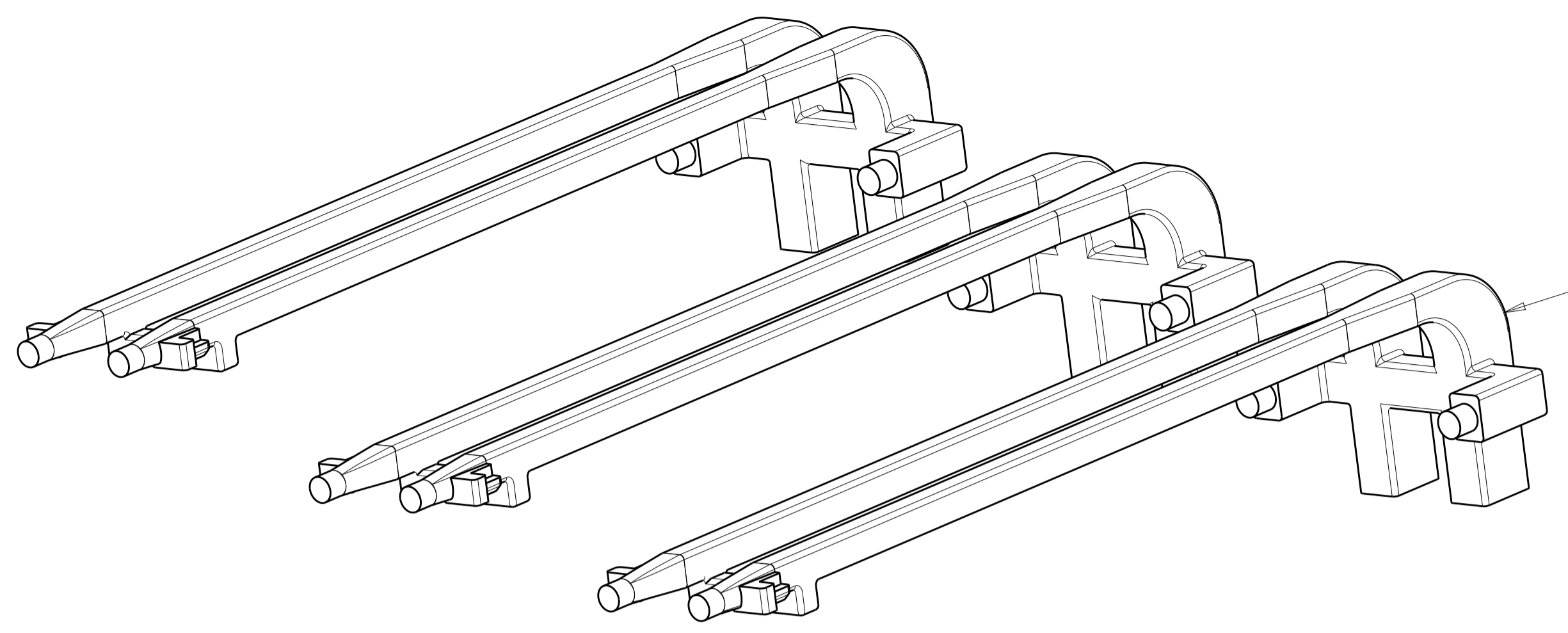

DOUBLE LIGHT PIPES  
 QUANTITY: 3

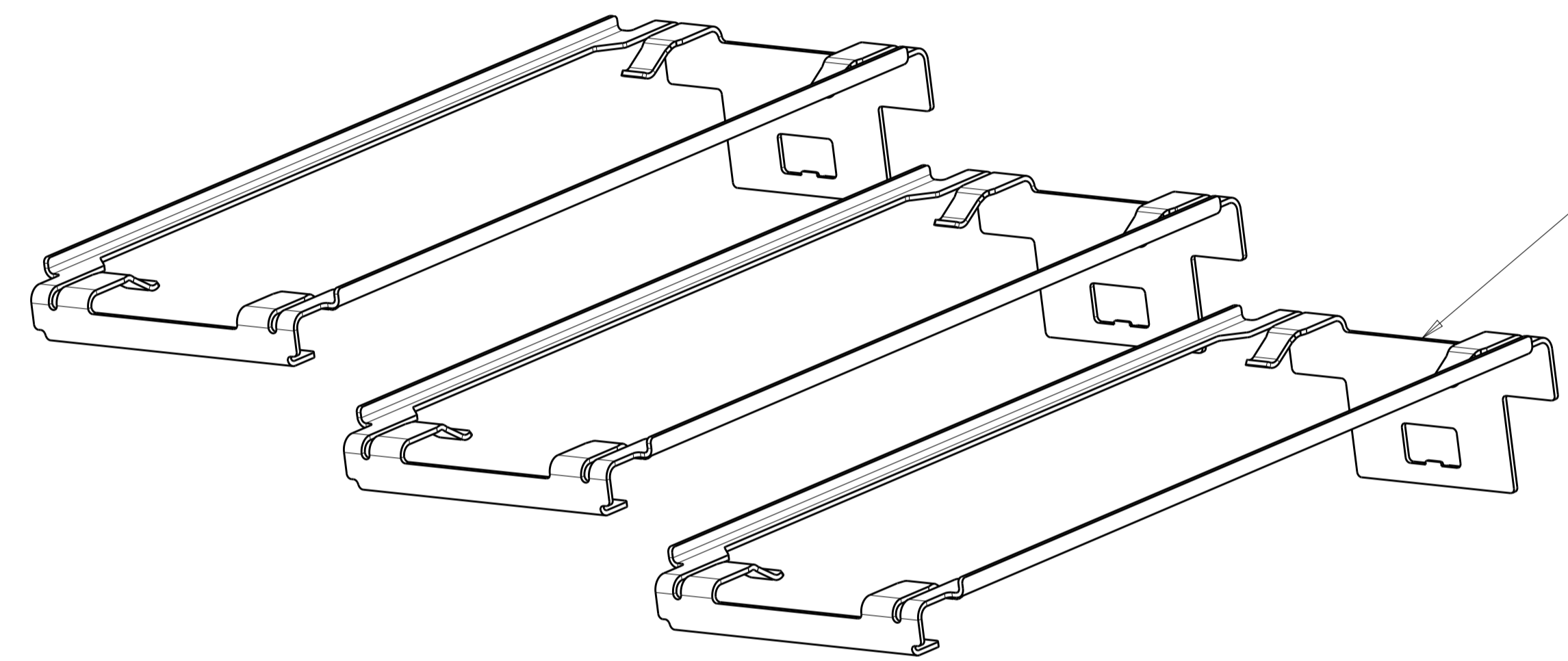

HEAT SINK CLIPS  
 QUANTITY: 3

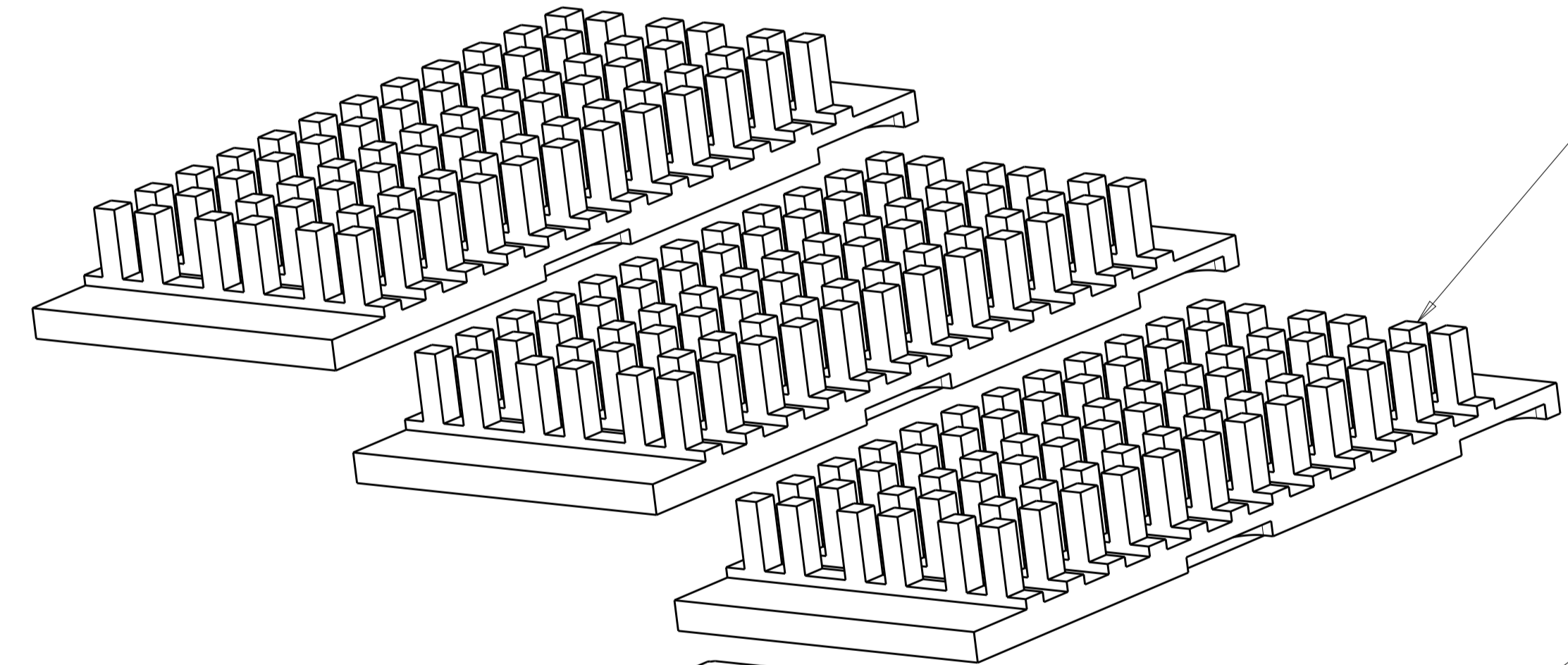

72 PIN HEAT SINKS  
 QUANTITY: 3

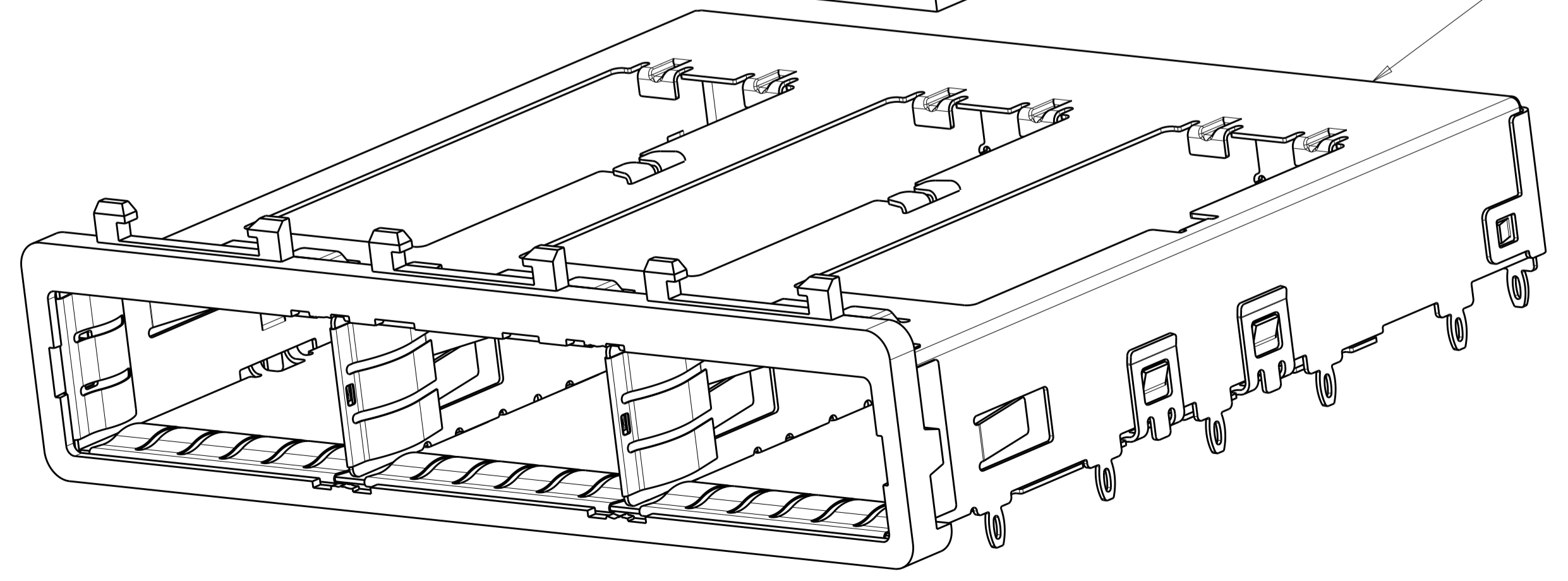

1X3 BEHIND BEZEL QSFP  
 CAGE ASSEMBLY  
 QUANTITY: 1

THIS PRODUCT HAS NOT COMPLETED  
 VALIDATION/QUALIFICATION TESTING

THIS DRAWING IS A CONTROLLED DOCUMENT.		DWN C. VALENTIN 28FEB2008	TE Connectivity
DIMENSIONS: mm		CHK E. BRIGHT 28FEB2008	
TOLERANCES UNLESS OTHERWISE SPECIFIED:		APVD E. BRIGHT 28FEB2008	NAME 1X3 CAGE ASSEMBLY, BEHIND BEZEL, W/ LIGHT PIPES AND HEAT SINKS, QSFP
0 PLC ±.1		PRODUCT SPEC	SIZE A100779C=2057042
1 PLC ±0.1		108-2286	RESTRICTED TO
2 PLC ±.1		APPLICATION SPEC	
3 PLC ±.1		114-13218	
4 PLC ±.1		WEIGHT	
ANGLES ±.1		CUSTOMER DRAWING	SCALE 4:1 SHEET 2 OF 5 REV F
FINISH			

LOC		DIST		REVISIONS			
GP	00	P	LTN	DESCRIPTION	DATE	OWN	APVD
-	-	-	-	SEE SHEET 1	-	-	-

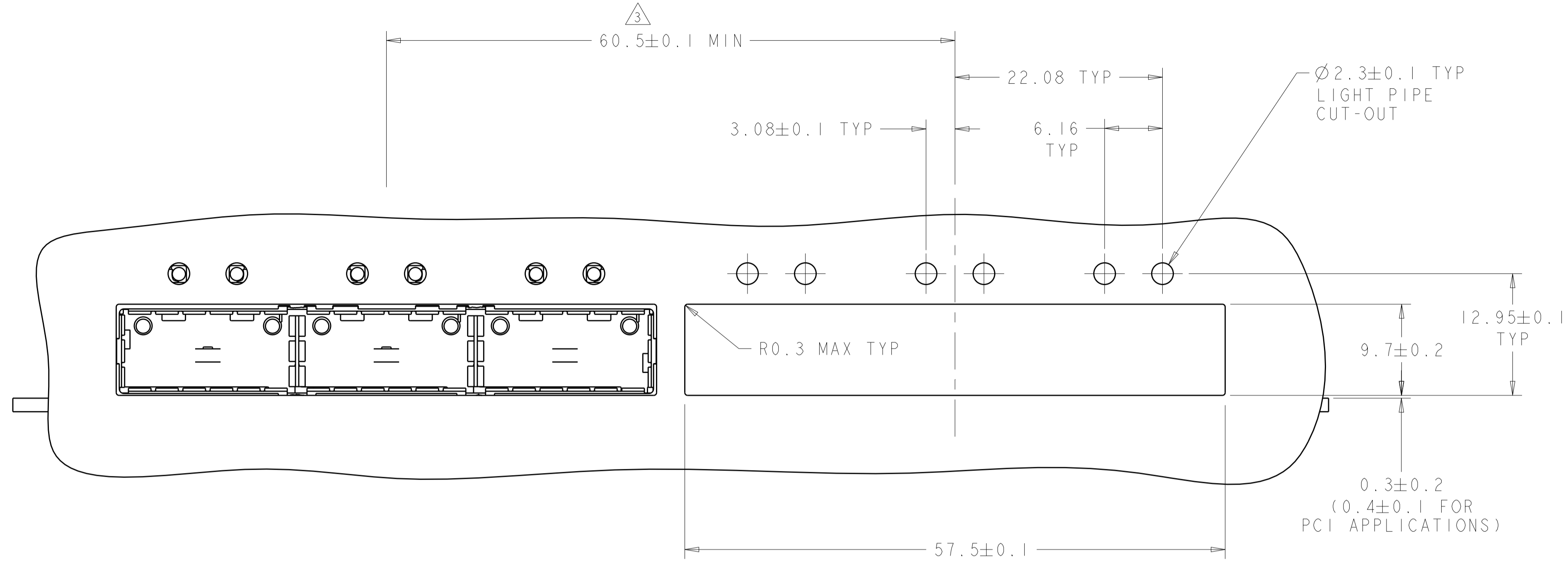

ONE SIDED CONFIGURATION  
 SCALE 3:1

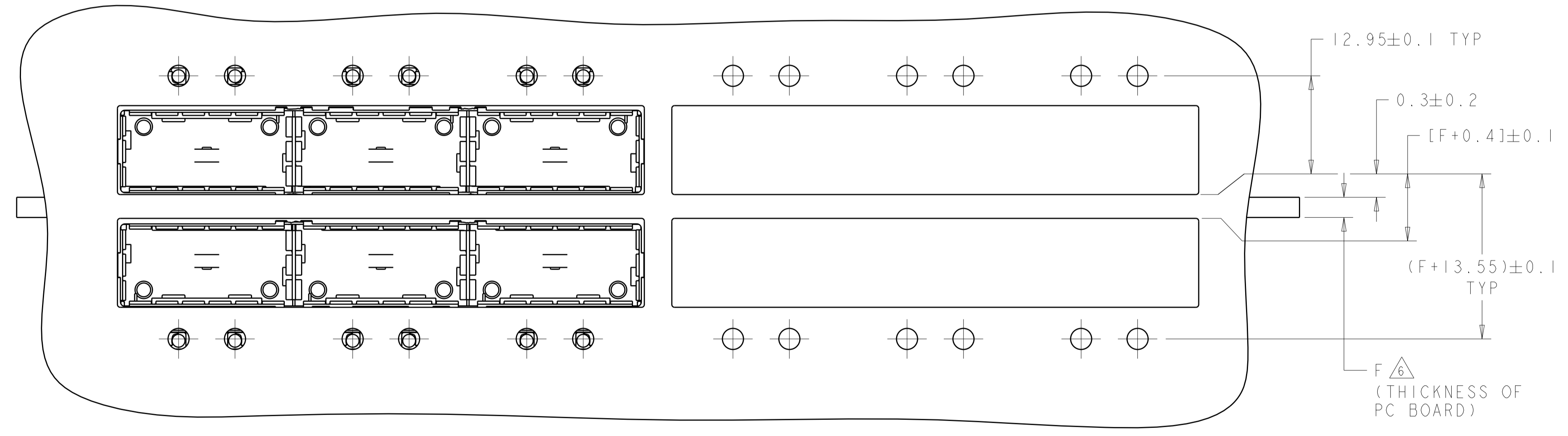
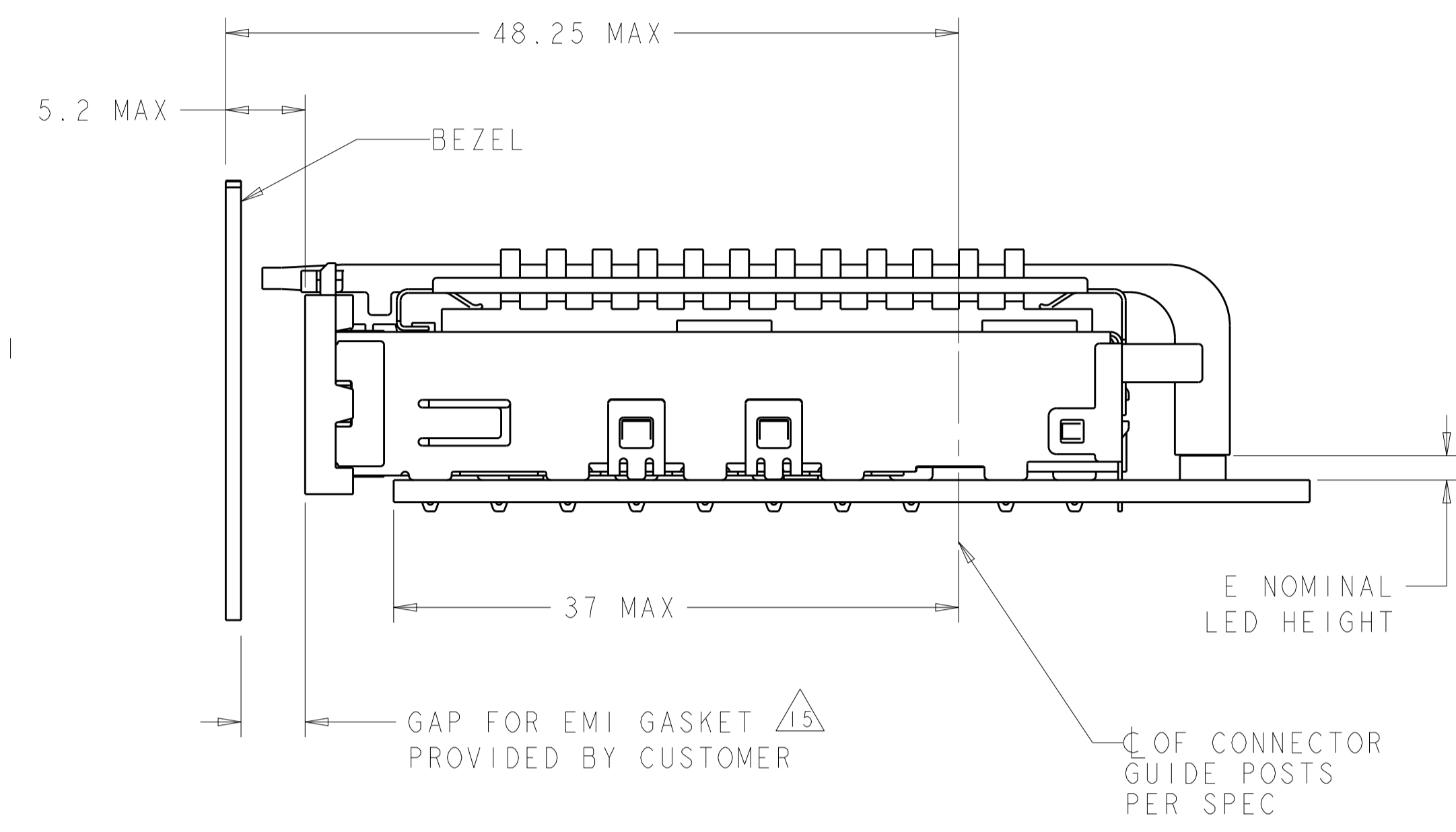

BELLY TO BELLY CONFIGURATION SIMILAR  
 TO ONE SIDED EXCEPT WHERE NOTED  
 SCALE 3:1

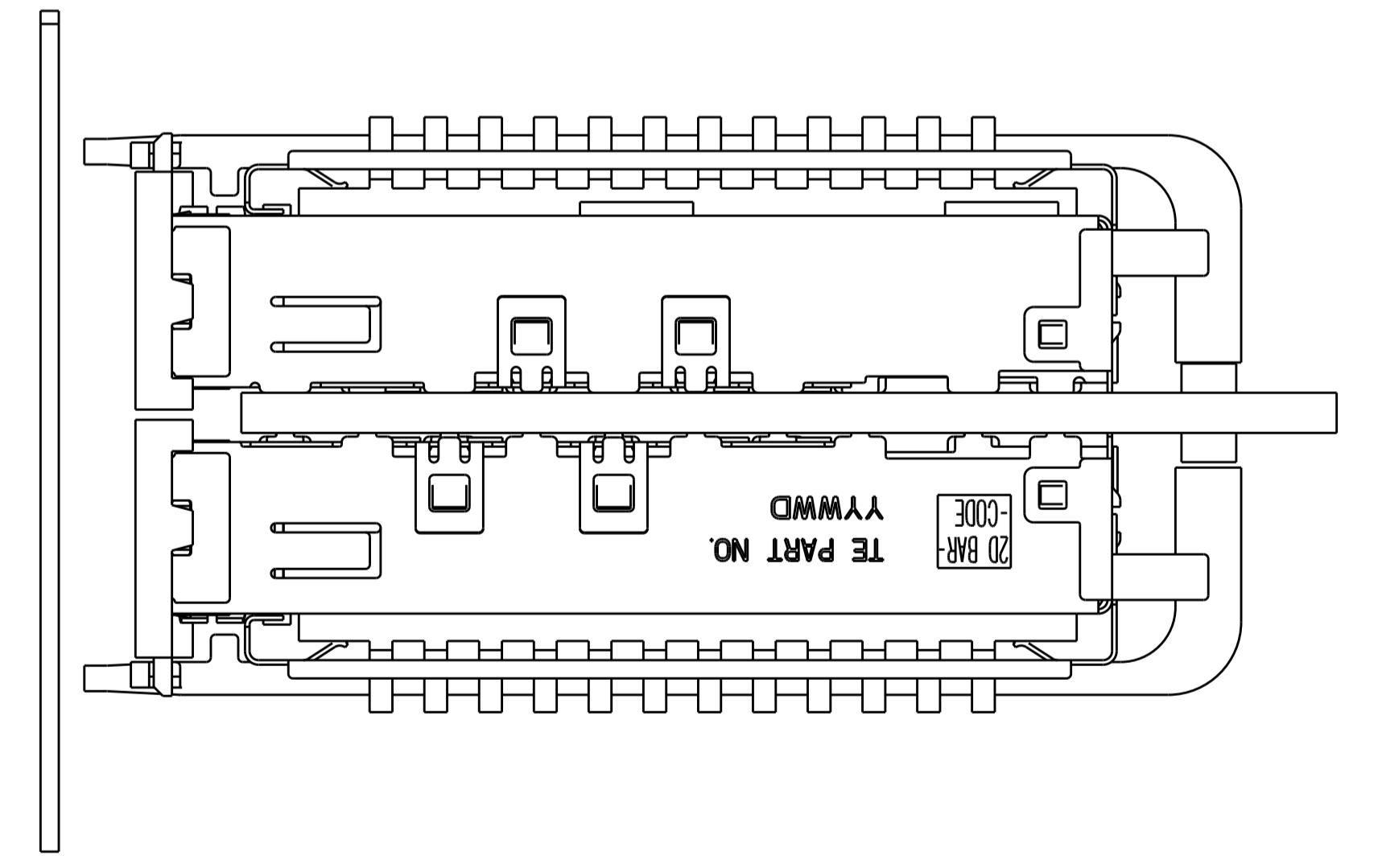

THIS PRODUCT HAS NOT COMPLETED VALIDATION/QUALIFICATION TESTING

THIS DRAWING IS A CONTROLLED DOCUMENT.		OWN C. VALENTINE 28FEB2008	
DIMENSIONS:		CHK E. BRIGHT 28FEB2008	
mm	TOLERANCES UNLESS OTHERWISE SPECIFIED:	APVD E. BRIGHT 28FEB2008	NAME 1X3 CAGE ASSEMBLY, BEHIND BEZEL, W/ LIGHT PIPES AND HEAT SINKS, QSFP
	0 PLC ± 1 PLC ±0.1 2 PLC ±0.1 3 PLC ± 4 PLC ± ANGLES ±	PRODUCT SPEC 108-2286	SIZE A100779
MATERIAL	FINISH	APPLICATION SPEC 114-13218	RESTRICTED TO
		WEIGHT	SCALE 4:1 SHEET 3 OF 5 REV F
		CUSTOMER DRAWING	

LOC	DIST	REVISIONS			
GP	00	REV	DATE	BY	APPV
-	-	SEE SHEET 1	-	-	-

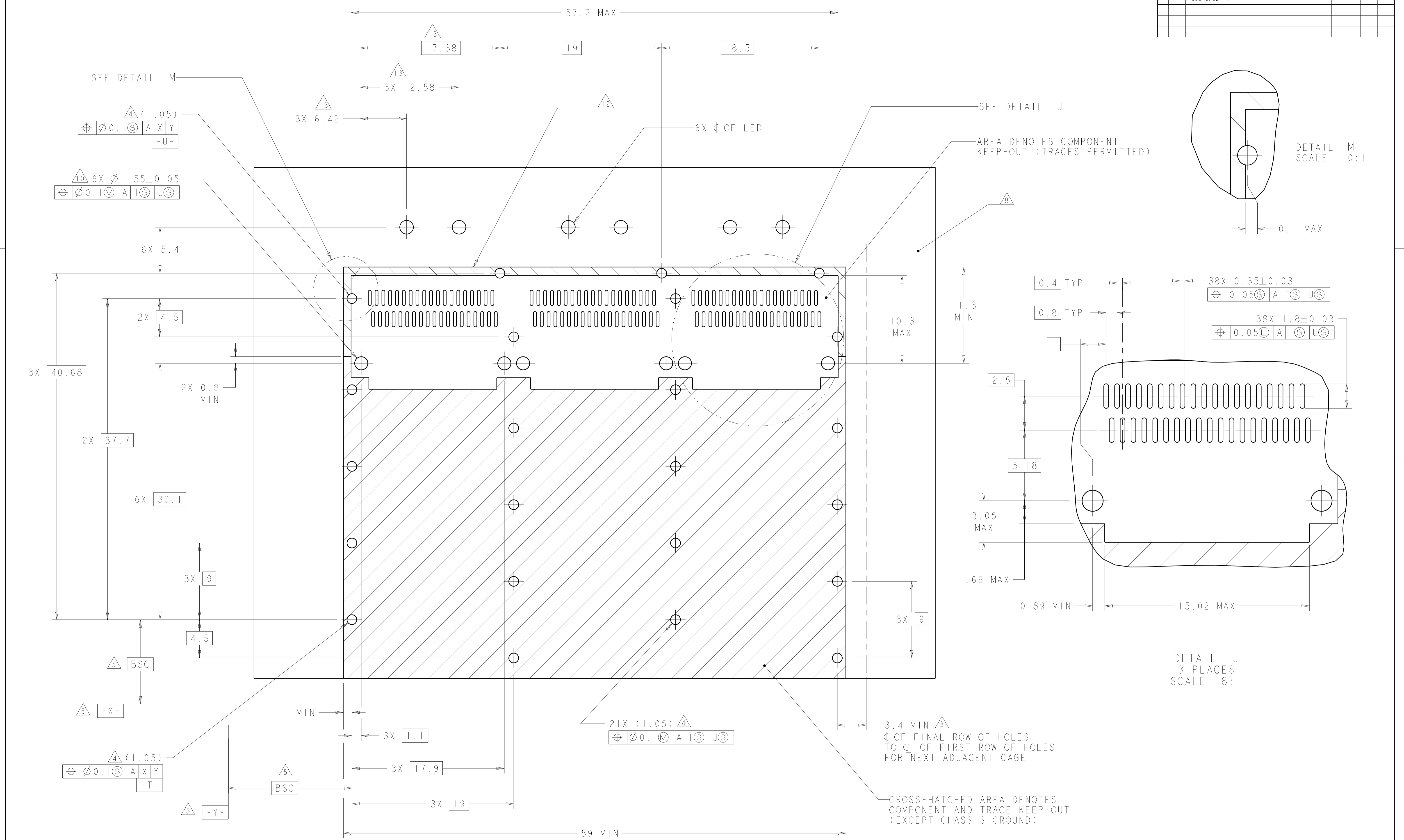

RECOMMENDED PC BOARD LAYOUT  
 SINGLE SIDE MOUNT CONFIGURATION  
 SCALE 5:1

THIS PRODUCT HAS NOT COMPLETED VALIDATION/QUALIFICATION TESTING

THIS DRAWING IS A CONTROLLED DOCUMENT.		DWN C. VALENTINE 28FEB2008	TE Connectivity												
DIMENSIONS: mm		CHK E. BRIGHT 28FEB2008													
TOLERANCES UNLESS OTHERWISE SPECIFIED:		APVD E. BRIGHT 28FEB2008	NAME 1X3 CAGE ASSEMBLY, BEHIND BEZEL, W/ LIGHT PIPES AND HEAT SINKS, QSFP												
<table border="1"> <tr><td>0 PLC</td><td>±</td></tr> <tr><td>1 PLC</td><td>±0.1</td></tr> <tr><td>2 PLC</td><td>±0.1</td></tr> <tr><td>3 PLC</td><td>±</td></tr> <tr><td>4 PLC</td><td>±</td></tr> <tr><td>ANGLES</td><td>±</td></tr> </table>		0 PLC	±	1 PLC	±0.1	2 PLC	±0.1	3 PLC	±	4 PLC	±	ANGLES	±	PRODUCT SPEC 108-2286	SIZE A100779
0 PLC	±														
1 PLC	±0.1														
2 PLC	±0.1														
3 PLC	±														
4 PLC	±														
ANGLES	±														
MATERIAL		APPLICATION SPEC 114-13218	RESTRICTED TO												
FINISH		WEIGHT	SCALE 4:1 SHEET 4 OF 5 REV F												
CUSTOMER DRAWING		©=2057042													

LOC		DIST		REVISIONS				
GP	00	P	LTN	DESCRIPTION	DATE	DWN	APVD	
		-		SEE SHEET 1				

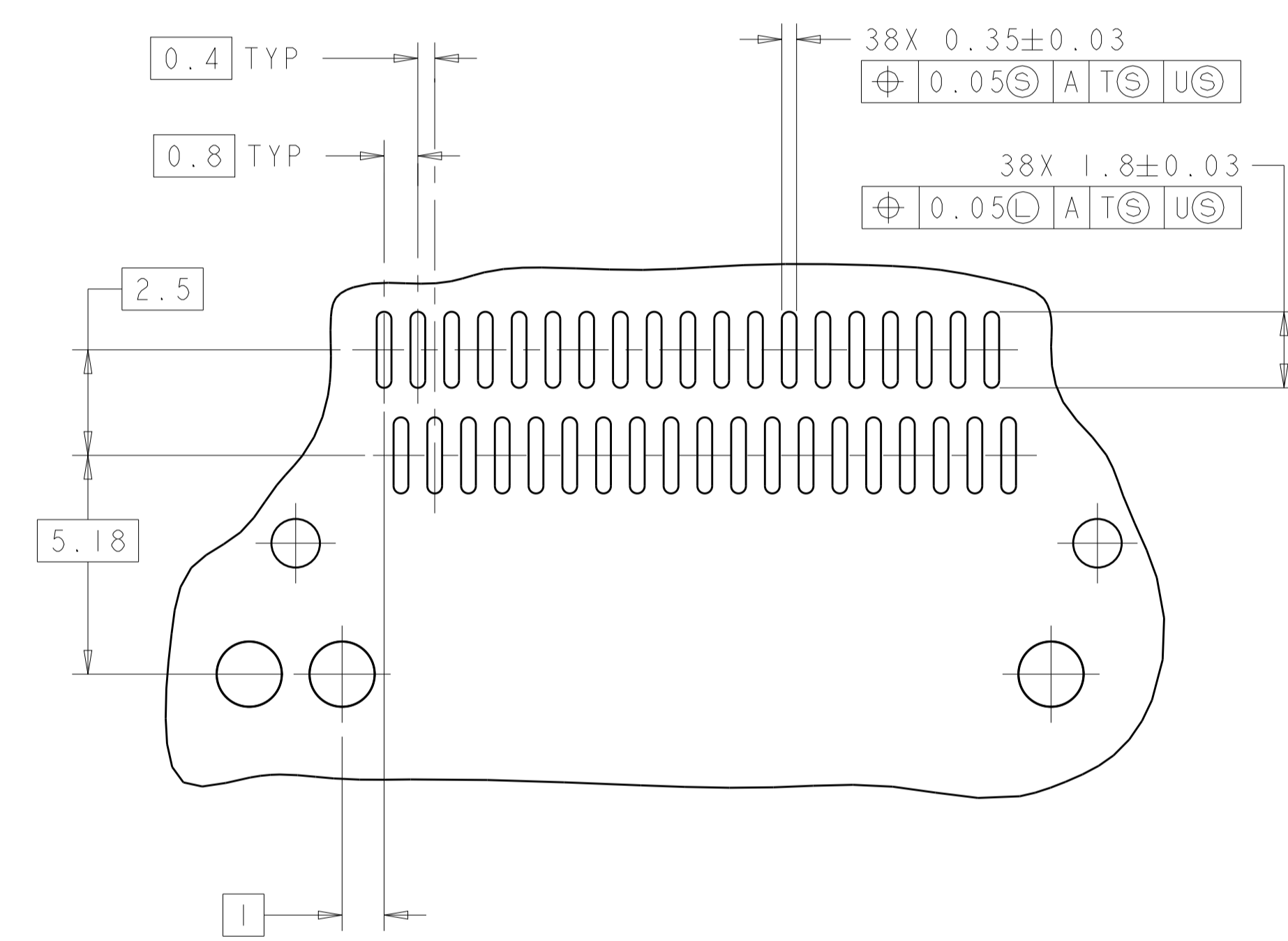
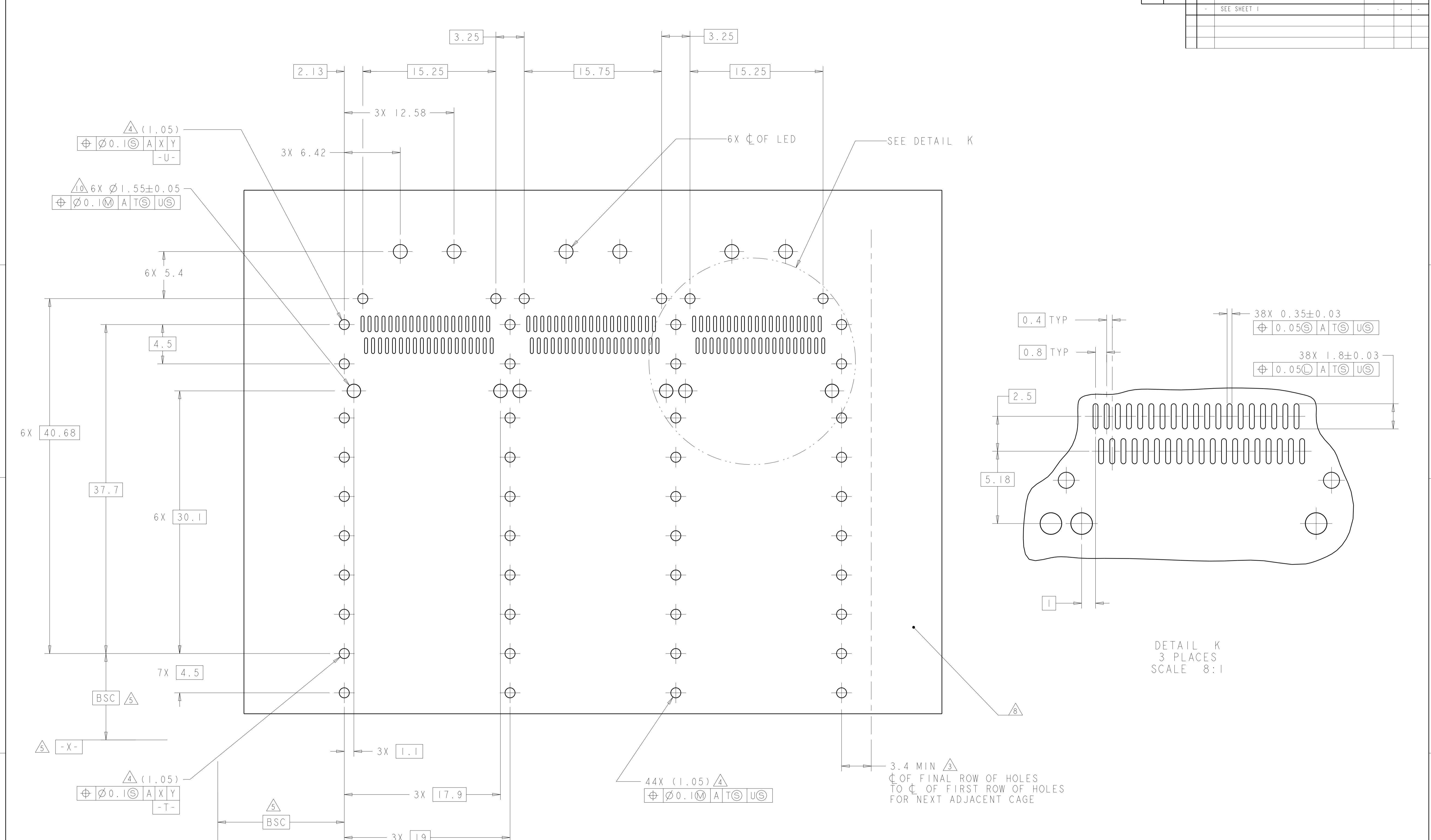

DETAIL K  
 3 PLACES  
 SCALE 8:1

RECOMMENDED PC BOARD LAYOUT  
 BELLY TO BELLY CONFIGURATION  
 SEE SHEET 4 FOR COMPONENT  
 AND TRACE KEEP-OUTS  
 SCALE 5:1

THIS PRODUCT HAS NOT COMPLETED VALIDATION/QUALIFICATION TESTING

THIS DRAWING IS A CONTROLLED DOCUMENT.		DWN C. VALENTINE 28FEB2008	TE Connectivity														
DIMENSIONS: mm		CHK E. BRIGHT 28FEB2008															
TOLERANCES UNLESS OTHERWISE SPECIFIED:		APVD E. BRIGHT 28FEB2008	NAME 1X3 CAGE ASSEMBLY, BEHIND BEZEL, W/ LIGHT PIPES AND HEAT SINKS, QSFP														
<table border="1"> <tr><td>0 PLC</td><td>±</td></tr> <tr><td>1 PLC</td><td>±0.1</td></tr> <tr><td>2 PLC</td><td>±0.1</td></tr> <tr><td>3 PLC</td><td>±</td></tr> <tr><td>4 PLC</td><td>±</td></tr> <tr><td>ANGLES</td><td>±</td></tr> <tr><td>FINISH</td><td>±</td></tr> </table>		0 PLC	±	1 PLC	±0.1	2 PLC	±0.1	3 PLC	±	4 PLC	±	ANGLES	±	FINISH	±	PRODUCT SPEC 108-2286	SIZE A100779
0 PLC	±																
1 PLC	±0.1																
2 PLC	±0.1																
3 PLC	±																
4 PLC	±																
ANGLES	±																
FINISH	±																
MATERIAL		APPLICATION SPEC 114-13218	CAGE CODE DRAWING NO C=2057042														
		WEIGHT	RESTRICTED TO														
		CUSTOMER DRAWING	SCALE 4:1 SHEET 5 OF 5 REV F														

## X-ON Electronics

Largest Supplier of Electrical and Electronic Components

*Click to view similar products for [I/O Connectors](#) category:*

*Click to view products by [TE Connectivity](#) manufacturer:*

Other Similar products are found below :

[571763P](#) [72.250.1628.2](#) [72.250.2428.2](#) [74720-0505](#) [76.350.0729.0](#) [76871-1403](#) [FCN-244F080-G/1](#) [FCN-260A9920](#) [MP-5T180MUNNA-005](#)  
[PCR-E36PM](#) [PCS-XE26MA+](#) [G38A71314B](#) [1571250010](#) [157-22500-3](#) [MS3471L14-19P L/C](#) [91-569786-35H](#) [172501-4002](#) [172501-6002](#)  
[FCN-260C008-A/L0](#) [FCN-260C024-AL0](#) [FCN-261Z008](#) [2000314-1](#) [200331-1](#) [PCR-E36FC+](#) [PCS-E28FS+](#) [PCS-XE26SLFD+](#) [PCS-](#)  
[XE26SLFDT+](#) [G730VID08BDC24](#) [U90B2054081210](#) [UE86K842720321](#) [38113800006](#) [DP3AR020WQ1R200](#) [Z4.102.0680.0](#) [500-1040](#)  
[500-1052](#) [500-1054](#) [ZP-4008-66L](#) [0709821002](#) [10-565995-597N](#) [DX40-20P\(55\)](#) [5554841-1](#) [MS3474W18-8P-LC\\*](#) [U90B3054061110](#) [U65-](#)  
[E04-4020](#) [ZPF000000000097891](#) [557-262M2-06C](#) [747360449](#) [10099439-003C-TRLF](#) [10137239-0021LF](#) [E9320-001-01](#)