

Z-PACK TinMan 85 ohm Connector Overview

Product Facts

- 10+ Gbps performance
- 85 ohm impedance for differential pair configuration
- 5 pair version offers 26 pairs/10mm [66 differential pairs/inch] fitting within a 25.40 [1.00] card slot pitch
- 3 pair version offers 16 pairs/10mm [40 differential pairs/inch] fitting within a 16.25 [.625] card slot pitch
- Right angle pin headers (coplanar) in 3 pair and 5 pair versions
- Vertical receptacles (mezzanine) in 5 pair version
- High speed cable assemblies and hardware
- Reliable, redundant contact design on every signal contact
- Modular system offered in various column versions
- Meets industry reliability requirements of Bellcore/Telcordia
- Sequencing for ground and signal contacts
- RoHS compliant

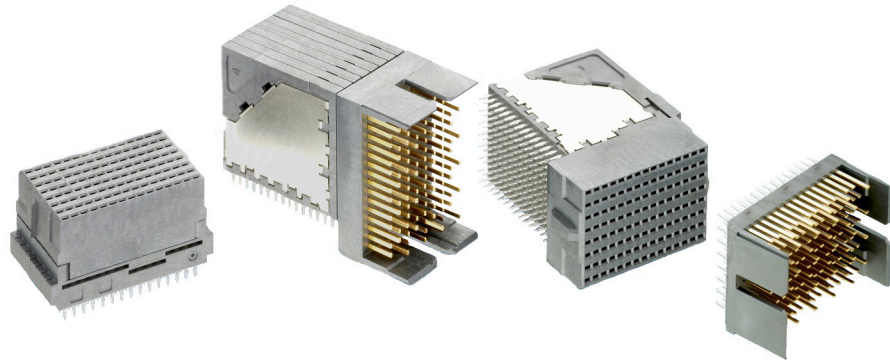

Increasing system performance is a continuous challenge within the interconnection channel. One design approach gaining momentum in the industry is the reduction of the system characteristic impedance from 100 ohm to 85 ohm. Such a reduction of impedance from 100 ohm to 85 ohm can improve overall system performance by incorporating thinner PC boards, increasing density with same board thickness and making it easier to match the system impedance to the connector footprint impedance.

Tyco Electronics is leading the way in providing a complete interconnect solution for this emerging market. The suite of Z-PACK TinMan 85 ohm connectors provides the same industry leading performance and features and benefits designed into the standard 100 ohm Z-PACK TinMan connector system but in an 85 ohm impedance package. This connector was designed to provide 85 ohm nominal characteristic impedance through the entire connector, from PCB footprint to PCB footprint.

As part of the complete Z-PACK TinMan connector product family, the 85 ohm version offers protected right-angle and vertical receptacles for use on daughtercards and mezzanine boards where handling damage can be a concern when plugging to a mating header. Ground contacts strategically positioned within each column of the connector, combined with unique contact lead frame arrangements, enable the Z-PACK TinMan 85 ohm connector to achieve low crosstalk and high throughput performance levels. A dual point of contact mating interface and compliant pin interface to printed circuit board help provide reliability.

Industry Applications

The Z-PACK TinMan 85 ohm connector family is designed for the cost pressured, high performance, high signal density, blade and rack mount server applications implementing an 85 ohm system impedance.

Technical Documents

Product Specification 108-2303-1

Application Specification 114-13243

Routing Guide Report #27GC001-1

Material and Finish

Signal Contact — High Strength Copper Alloy

Ground Contact — High Strength Copper Alloy

Housing — Liquid Crystal Polymer, UL 94V-0 Rated

Platings — Telcordia compliant interface, Nickel underplate

Compliant Pin Plating — RoHS Compliant

Ratings

Temperature Range — -65°C to +90°C

Current Rating — 0.5 A/contact @ < 30°C T-Rise

Durability — 200 cycles

Dielectric Withstanding Voltage — 560 VAC

Operating Voltage — 250 VAC max.

Signal Integrity

Characteristic Impedance — Differential @ 85 ohms $\pm 10\%$

Crosstalk — Multi-pair differential crosstalk: 2.1% @ 50ps

Insertion Loss — -2 dB @ 10 GHz

TELCORDIA is a trademark of Telcordia Technologies, Inc.

For additional information visit:

<http://www.tycoelectronics.com/products/tinman85ohm>

Note: All part numbers are RoHS compliant.

5 Pair Right Angle Receptacle Assemblies (85 ohm)

Column	Part Number	Dimension		Application Tooling	Mates With
		A	B		
8	1934954-1	15.35 .604	13.30 .524	*	1934947-1, 2065053-1, 2065305-1, 2065307-1, 1934948-1, 1934985-1, 2065739-1, 2065738-1
10	1934932-1	19.15 .754	17.10 .673	*	1934822-1, 2065027-1, 2065309-1, 2065311-1, 1934937-1, 2065025-1, 2065740-1, 2065741-1
16	2065042-1	30.55 1.203	28.50 1.122	*	2065054-1, 2065055-1, 2065329-1, 2065331-1, 1934986-1, 1934987-1, 2065748-1, 2065749-1

* Custom tooling not required. Utilizes flat-rock insertion tooling. Reference Application Specification 114-13243.

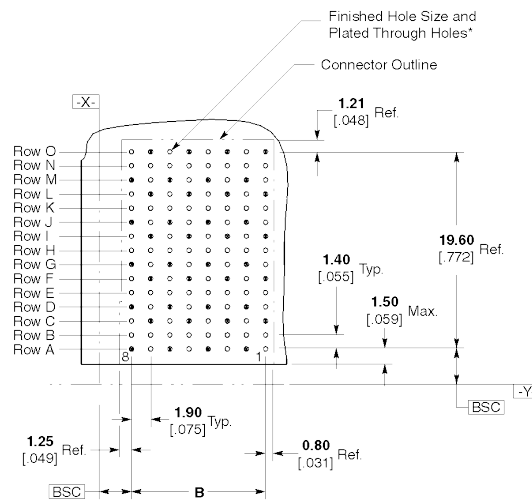
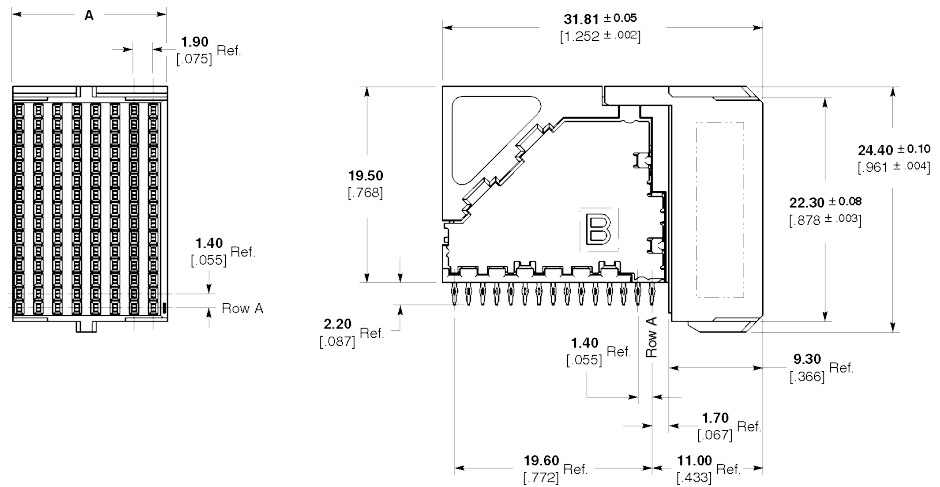

Recommended PC Board Layout
Daughterboard
Component Side Shown

Note: For additional information on pcb routing guidelines, reference the Z-PACK TinMan Connector Routing Guide Report #27GC001-1.

* Finished Hole Diameter = 0.46 ± 0.05 [018 ± 0.002]
 Drilled Hole Diameter = 0.55 ± 0.02 [022 ± 0.001]
 Copper Thickness = 0.038 ± 0.013 [0015 ± 0.0005]
 Tin-Lead Thickness = 0.008 ± 0.004 [0003 ± 0.0002]
 Finishes other than Tin-Lead, See Appl. Spec. 114-13243

Note: All part numbers are RoHS compliant. Tin-Lead parts are RoHS compliant through exemption for lead in press-fit connectors.

3 Pair Right Angle Receptacle Assemblies (85 ohm)

Column	Part Number	Dimension		Application Tooling	Mates With
		A	B		
8	1934811-1	15.35 .604	13.30 .524	*	1934806-1, 2065043-1, 2065237-1, 2065239-1, 1934974-1, 1934975-1 2065704-1, 2065705-1
10	1934951-1	19.15 .754	17.10 .673	*	1934950-1, 2065044-1, 2065790-1, 2065791-1, 1934976-1, 1934977-1 2065706-1, 2065707-1
16	2065038-1	30.55 1.203	28.50 1.122	*	2065045-1, 2065046-1, 2065257-1, 2065259-1, 1934978-1, 1934979-1, 2065716-1, 2065717-1

* Custom tooling not required. Utilizes flat-rock insertion tooling. Reference Application Specification 114-13243.

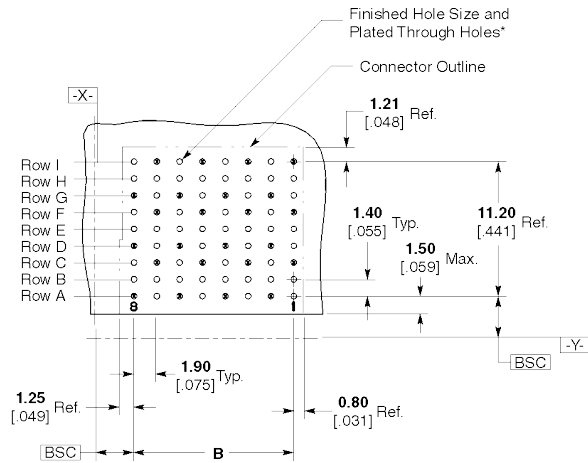
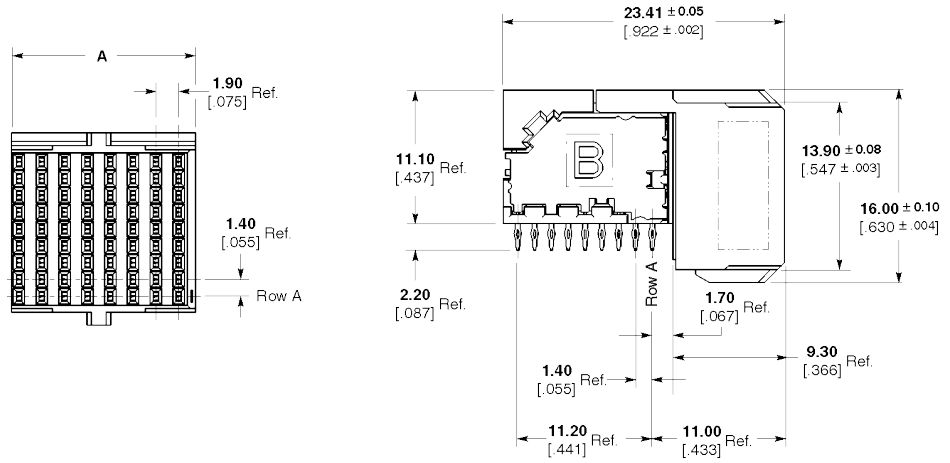

Recommended PC Board Layout Daughterboard Component Side Shown

Note: For additional information on pcb routing guidelines, reference the Z-PACK TinMan Connector Routing Guide Report #27GC001-1.

* Finished Hole Diameter = 0.46 ± 0.05 [.018 ± .002]
 Drilled Hole Diameter = 0.55 ± 0.02 [.022 ± .001]
 Copper Thickness = 0.038 ± 0.013 [.0015 ± .0005]
 Tin-Lead Thickness = 0.008 ± 0.004 [.0003 ± .0002]
 Finishes other than Tin-Lead, See Appl. Spec. 114-13243

Note: All part numbers are RoHS compliant. Tin-Lead parts are RoHS compliant through exemption for lead in press-fit connectors.

5 Pair Vertical Receptacle Assemblies - 15 mm Stack Height Version (85 ohm)

Column	Part Number	Dimension		Application Tooling	Mates With
		A	B		
8	1934949-1	15.35 .605	13.30 .524	*	1934947-1, 2065053-1, 2065305-1, 2065307-1, 1934948-1, 1934985-1, 2065738-1, 2065739-1
10	2065024-1	19.15 .754	17.10 .673	*	1934822-1, 2065309-1, 2065311-1, 2065027-1, 1934937-1, 2065025-1, 2065740-1, 2065741-1
16	1934973-1	30.70 1.210	28.50 1.122	*	2065054-1, 2065055-1, 2065329-1, 2065331-1, 1934986-1, 1934987-1, 2065748-1, 2065749-1

* Custom tooling not required. Utilizes flat-rock insertion tooling. Reference Application Specification 114-13243.

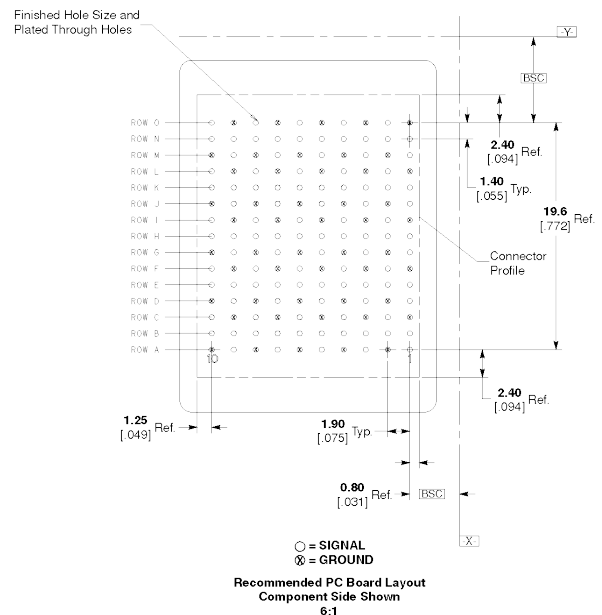
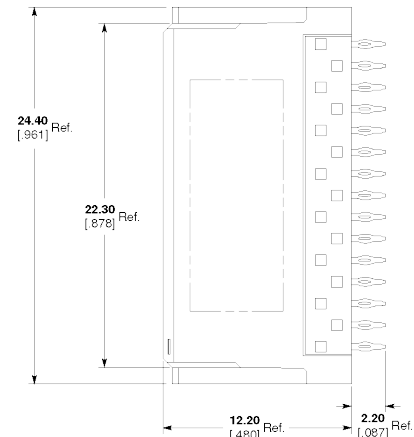
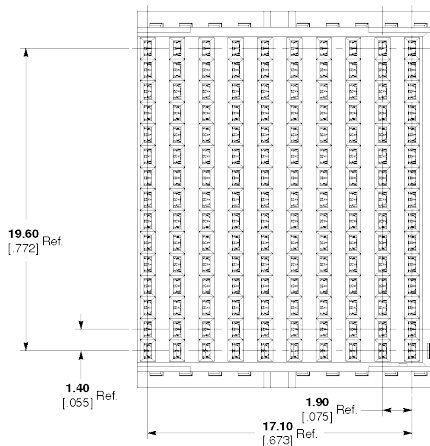

Note: For additional information on pcb routing guidelines, reference the Z-PACK TinMan Connector Routing Guide Report #27GC001-1.

* Finished Hole Diameter = 0.46 ± 0.05 [0.018 ± 0.002]
 Drilled Hole Diameter = 0.55 ± 0.02 [0.022 ± 0.001]
 Copper Thickness = 0.038 ± 0.013 [0.0015 ± 0.0005]
 Tin-Lead Thickness = 0.008 ± 0.004 [0.0003 ± 0.0002]
 Finishes other than Tin-Lead, See Appl. Spec. 114-13243

Note: All part numbers are RoHS compliant. Tin-Lead parts are RoHS compliant through exemption for lead in press-fit connectors.

5 Pair Vertical Receptacle Assemblies - 39 mm Stack Height Version (85 ohm)

Column	Part Number	Dimension		Application Tooling	Mates With
		A	B		
8	2065490-1	15.35 [.605]	13.30 [.524]	*	1934947-1, 2065053-1, 2065305-1, 2065307-1, 1934948-1, 1934985-1, 2065738-1, 2065739-1
10	2065599-1	19.15 [.754]	17.10 [.673]	*	1934822-1, 2065309-1, 2065311-1, 2065027-1, 1934937-1, 2065025-1, 2065740-1, 2065741-1
16	2065493-1	30.70 [1.210]	28.50 [1.122]	*	2065054-1, 2065055-1, 2065329-1, 2065331-1, 1934986-1, 1934987-1, 2065748-1, 2065749-1

* Custom tooling not required. Utilizes flat-rock insertion tooling. Reference Application Specification 114-13243.

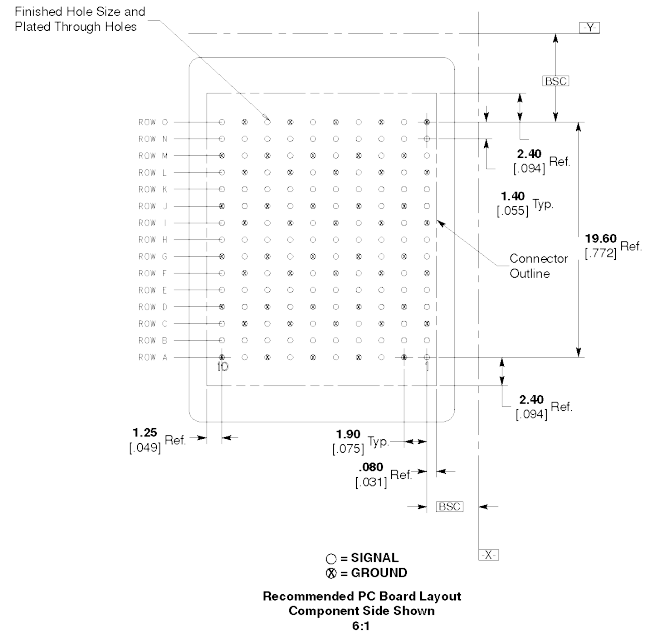
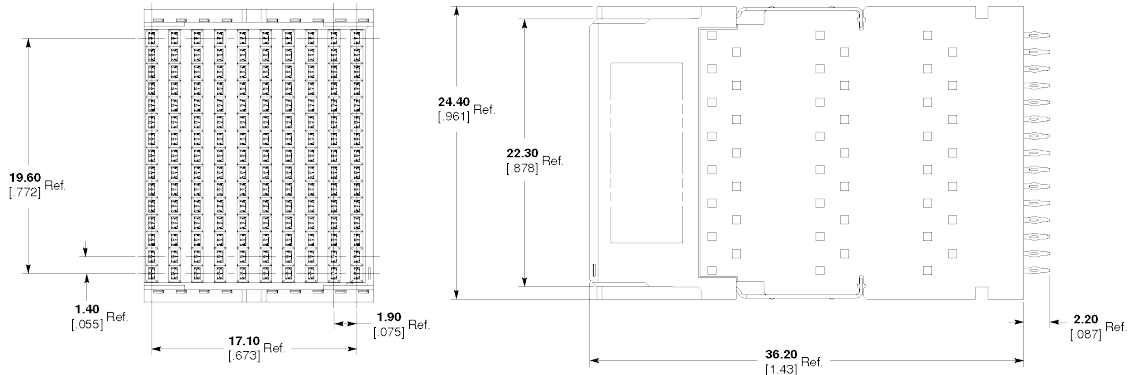

Note: For additional information on pcb routing guidelines, reference the Z-PACK TinMan Connector Routing Guide Report #27GC001-1.

* Finished Hole Diameter = 0.46 ± 0.05 [.018 ± .002]
 Drilled Hole Diameter = 0.55 ± 0.02 [.022 ± .001]
 Copper Thickness = 0.038 ± 0.013 [.0015 ± .0005]
 Tin-Lead Thickness = 0.008 ± 0.004 [.0003 ± .0002]
 Finishes other than Tin-Lead, See Appl. Spec. 114-13243

Note: All part numbers are RoHS compliant. Tin-Lead parts are RoHS compliant through exemption for lead in press-fit connectors.

5 Pair Vertical Header Assemblies (85 ohm)

Column	Part Number	Dimension		Application Tooling*	Mates With
		A	B		
8	1934985-1	15.35 .604	13.30 .524	1934957-1	1934954-1, 1934949-1, 2065490-1
10	1934937-1	19.15 .754	17.10 .673	1934957-2	1934932-1, 2065024-1, 2065599-1
16	1934987-1	30.55 1.203	28.50 1.122	1934957-4	2065042-1, 1934973-1, 2065493-1

* Reference Application Specification 114-13243.

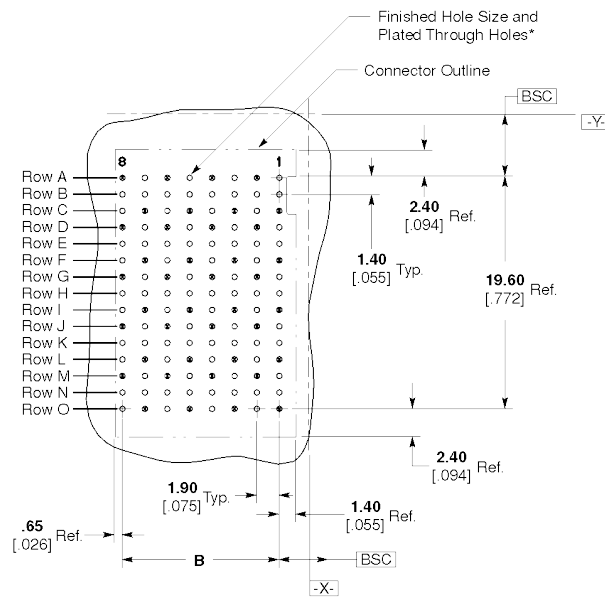
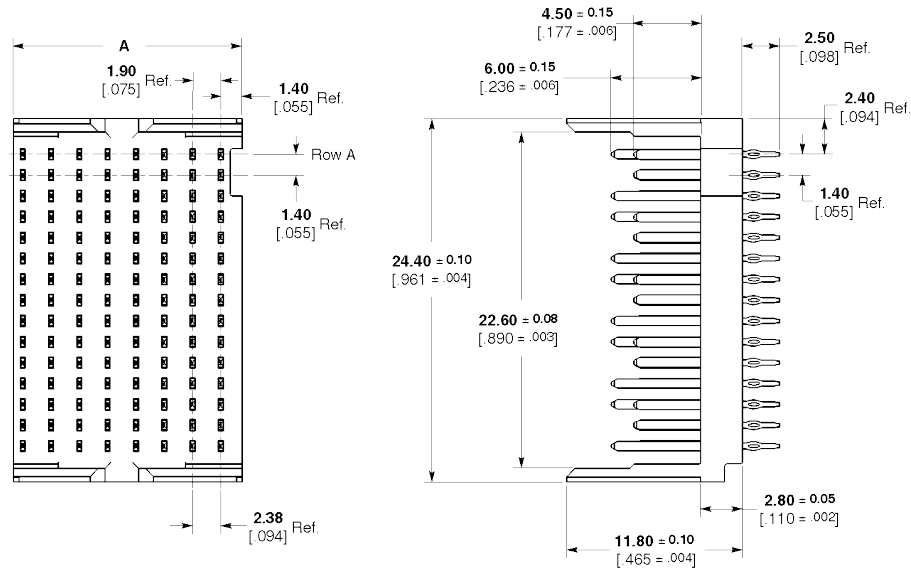

Recommended PC Board Layout
Backplane
Component Side Shown

Note: All part numbers are RoHS compliant. Tin-Lead parts are RoHS compliant through exemption for lead in press-fit connectors.

Note: For additional information on pcb routing guidelines, reference the Z-PACK TinMan Connector Routing Guide Report #27GC001-1.

* Finished Hole Diameter = 0.46 ± 0.05 [0.018 ± .002]
 Drilled Hole Diameter = 0.55 ± 0.02 [0.022 ± .001]
 Copper Thickness = 0.038 ± 0.013 [0.0015 ± .0005]
 Tin-Lead Thickness = 0.008 ± 0.004 [0.0003 ± .0002]
 Finishes other than Tin-Lead, See Appl. Spec. 114-13243

5 Pair Vertical Header Assemblies - Left End Wall (85 ohm)

Column	Part Number	Dimension		Application Tooling*	Mates With
		A	B		
8	2065738-1	16.30 .642	13.30 .524	1934957-1	1934954-1, 1934949-1, 2065490-1
10	2065740-1	*	*	1934957-2	1934932-1, 2065024-1, 2065599-1
16	2065748-1	31.50 1.240	28.50 1.122	1934957-4	2065042-1, 1934973-1, 2065493-1

* Reference Application Specification 114-13243.

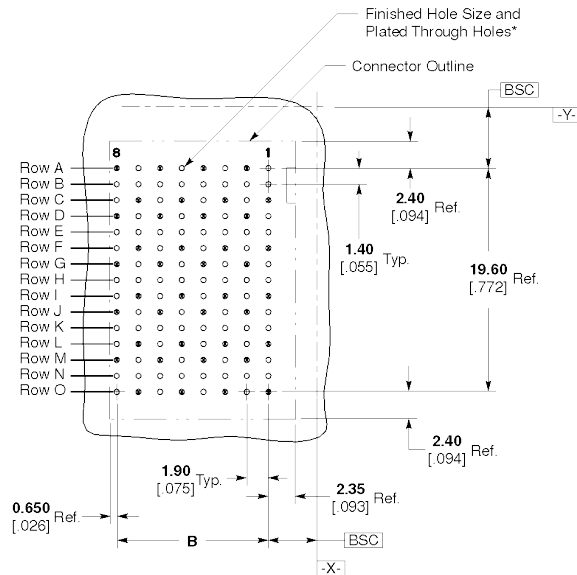
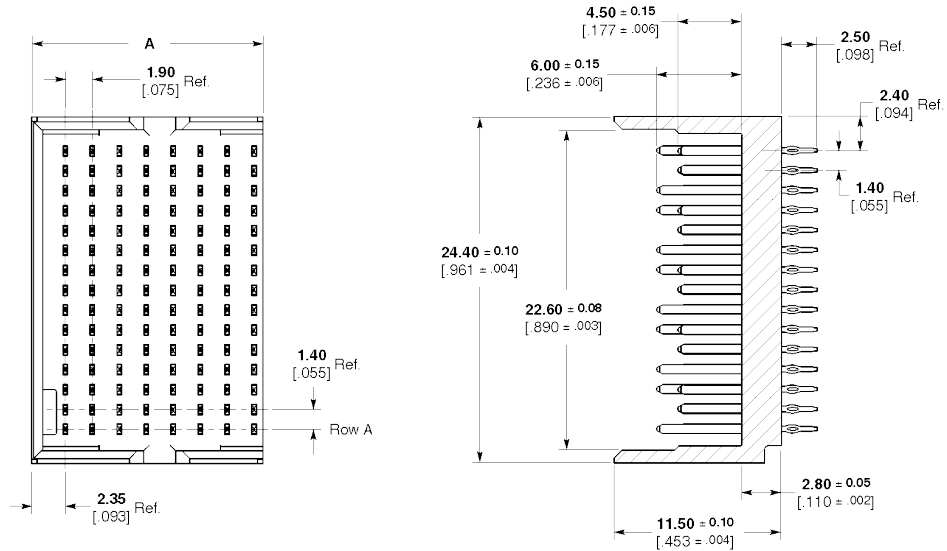

Recommended PC Board Layout Backplane Component Side Shown

Note: For additional information on pcb routing guidelines, reference the Z-PACK TinMan Connector Routing Guide Report #27GC001-1.

* Finished Hole Diameter = 0.46 ± 0.05 [0.18 ± 0.002]
 Drilled Hole Diameter = 0.55 ± 0.02 [0.22 ± 0.001]
 Copper Thickness = 0.038 ± 0.013 [0.015 ± 0.0005]
 Tin-Lead Thickness = 0.008 ± 0.004 [0.003 ± 0.0002]
 Finishes other than Tin-Lead, See Appl. Spec. 114-13243

Note: All part numbers are RoHS compliant. Tin-Lead parts are RoHS compliant through exemption for lead in press-fit connectors.

5 Pair Vertical Header Assemblies - Right Wall End (85 ohm)

Column	Part Number	Dimension		Application Tooling*	Mates With
		A	B		
8	2065739-1	17.00 .669	13.30 .524	1934957-1	1934954-1, 1934949-1, 2065490-1
10	2065741-1	*	*	1934957-2	1934932-1, 2065024-1, 2065599-1
16	2065749-1	32.20 1.268	28.50 1.122	1934957-4	2065042-1, 1934973-1, 2065493-1

* Reference Application Specification 114-13243.

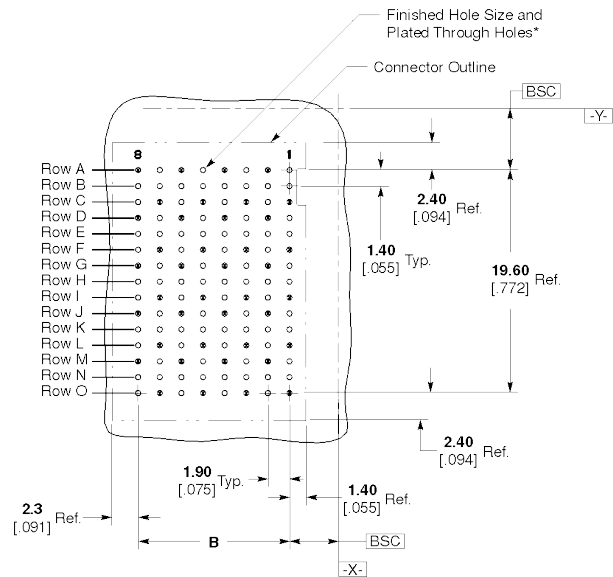
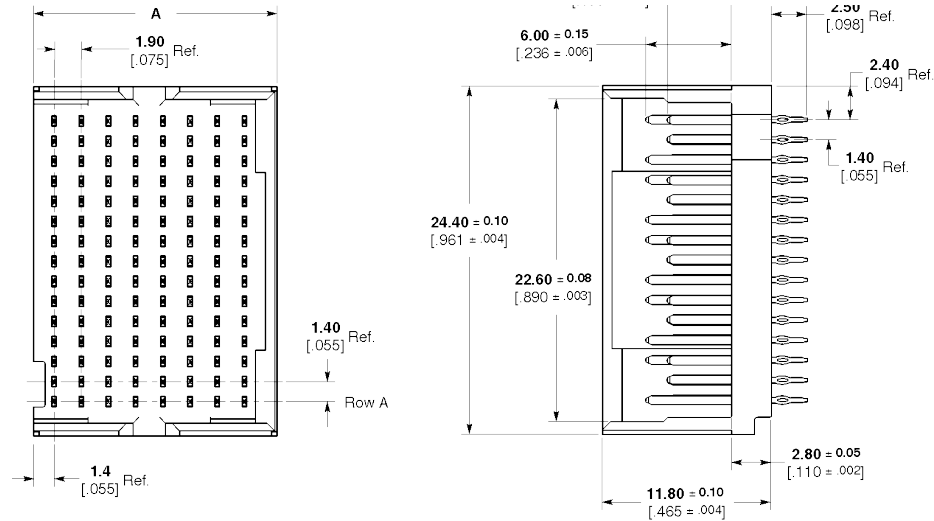

Note: For additional information on pcb routing guidelines, reference the Z-PACK TinMan Connector Routing Guide Report #27GC001-1.

* Finished Hole Diameter = **0.46 ± 0.05** [0.018 ± .002]
 Drilled Hole Diameter = **0.55 ± 0.02** [0.022 ± .001]
 Copper Thickness = **0.038 ± 0.013** [0.0015 ± .0005]
 Tin-Lead Thickness = **0.008 ± 0.004** [0.0003 ± .0002]
 Finishes other than Tin-Lead, See Appl. Spec. 114-13243

Note: All part numbers are RoHS compliant. Tin-Lead parts are RoHS compliant through exemption for lead in press-fit connectors.

5 Pair Vertical Header Assemblies - Double Wall Ends (85 ohm)

Column	Part Number	Dimension		Application Tooling*	Mates With
		A	B		
8	1934948-1	17.95 .707	13.30 .524	1934957-1	1934954-1, 1934949-1, 2065490-1
10	2065025-1	21.75 .856	17.10 .673	1934957-2	1934932-1, 2065024-1, 2065599-1
16	1934986-1	33.15 1.305	28.50 1.122	1934957-4	2065042-1, 1934973-1, 2065493-1

* Reference Application Specification 114-13243.

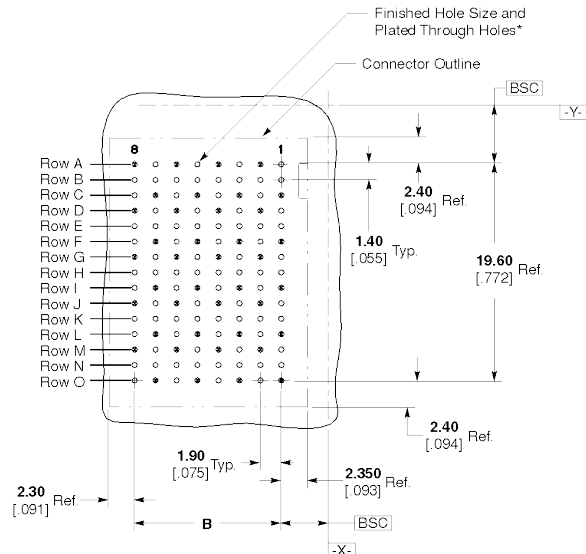
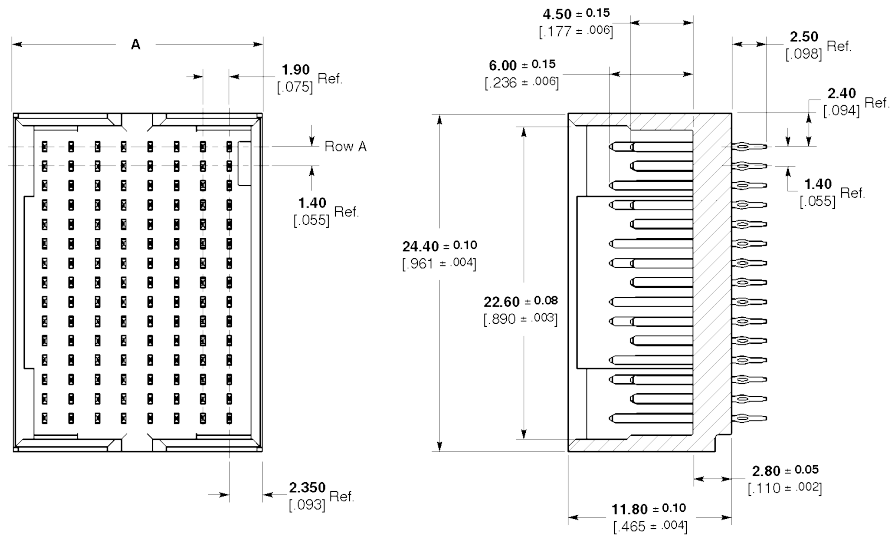

Recommended PC Board Layout Backplane Component Side Shown

Note: All part numbers are RoHS compliant. Tin-Lead parts are RoHS compliant through exemption for lead in press-fit connectors.

Note: For additional information on pcb routing guidelines, reference the Z-PACK TinMan Connector Routing Guide Report #27GC001-1.

* Finished Hole Diameter = 0.46 ± 0.05 [018 ± 002]
 Drilled Hole Diameter = 0.55 ± 0.02 [022 ± 001]
 Copper Thickness = 0.038 ± 0.013 [0015 ± 0005]
 Tin-Lead Thickness = 0.008 ± 0.004 [0003 ± 0002]
 Finishes other than Tin-Lead, See Appl. Spec. 114-13243

Note: All part numbers are RoHS compliant. Tin-Lead parts are RoHS compliant through exemption for lead in press-fit connectors.

3 Pair Vertical Header Assemblies (85 ohm)

Column	Part Number	Dimension		Application Tooling*	Mates With
		A	B		
8	1934975-1	15.35 .604	13.30 .524	2018398-1	1934811-1, 1934968-1, 2065474-1
10	1934977-1	19.15 .754	17.10 .673	2018398-1	1934951-1, 1934969-1, 2065475-1
16	1934979-1	30.55 1.203	28.50 1.122	2018398-2	2065038-1, 1934970-1, 2065478-1

* Reference Application Specification 114-13243.

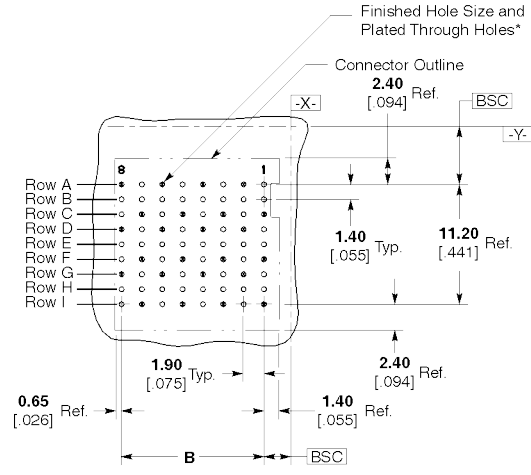
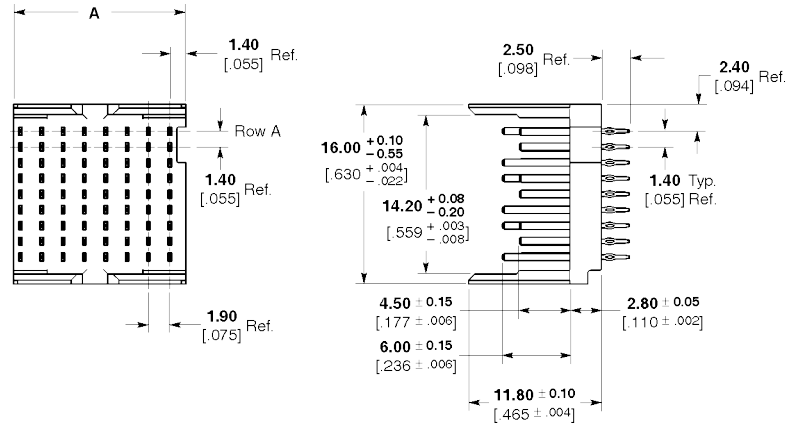

Recommended PC Board Layout
Component Side Shown

Note: For additional information on pcb routing guidelines, reference the Z-PACK TinMan Connector Routing Guide Report #27GC001-1.

* Finished Hole Diameter = 0.46 ± 0.05 [0.018 ±0.002]
 Drilled Hole Diameter = 0.55 ± 0.02 [0.022 ±0.001]
 Copper Thickness = 0.038 ± 0.013 [0.0015 ±0.0005]
 Tin-Lead Thickness = 0.008 ± 0.004 [0.0003 ±0.0002]
 Finishes other than Tin-Lead, See Appl. Spec. 114-13243

Note: All part numbers are RoHS compliant. Tin-Lead parts are RoHS compliant through exemption for lead in press-fit connectors.

3 Pair Vertical Header Assemblies - Left End Wall (85 ohm)

Column	Part Number	Dimension		Application Tooling*	Mates With
		A	B		
8	2065704-1	16.30 .642	13.30 .524	2018398-1	1934811-1, 1934968-1, 2065474-1
10	2065706-1	20.10 .791	17.10 .673	2018398-2	1934951-1, 1934969-1, 2065475-1
16	2065716-1	31.50 1.240	28.50 1.122	2018398-3	2065038-1, 1934970-1, 2065478-1

* Reference Application Specification 114-13243.

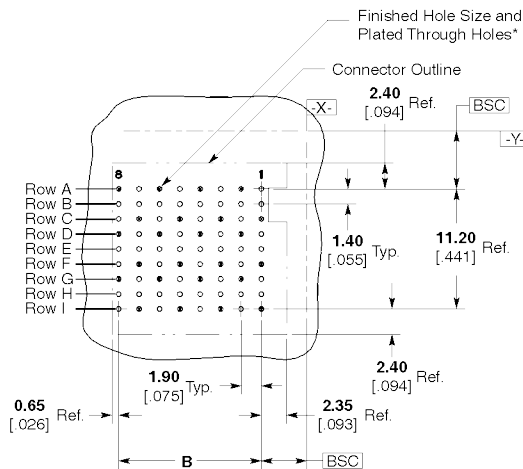
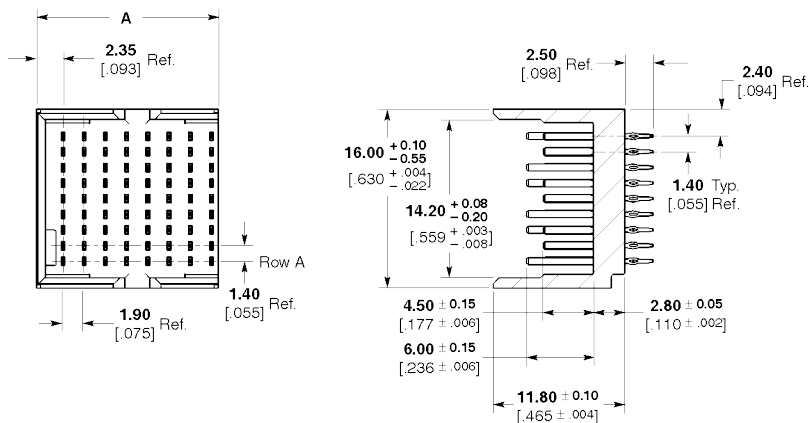

Recommended PC Board Layout
Component Side Shown

Note: For additional information on pcb routing guidelines, reference the Z-PACK TinMan Connector Routing Guide Report #27GC001-1.

* Finished Hole Diameter = 0.46 ± 0.05 [0.018 ± 0.002]
 Drilled Hole Diameter = 0.55 ± 0.02 [0.022 ± 0.001]
 Copper Thickness = 0.038 ± 0.013 [0.0015 ± 0.0005]
 Tin-Lead Thickness = 0.008 ± 0.004 [0.0003 ± 0.0002]
 Finishes other than Tin-Lead, See Appl. Spec. 114-13243

Note: All part numbers are RoHS compliant.

3 Pair Verical Header Assemblies - Right End Wall (85 ohm)

Column	Part Number	Dimension		Application Tooling*	Mates With
		A	B		
8	2065705-1	17.00 .669	13.30 .524	2018398-1	1934811-1, 1934968-1, 2065474-1
10	2065707-1	20.08 .791	17.10 .673	2018398-2	1934951-1, 1934969-1, 2065475-1
16	2065717-1	32.20 1.268	28.50 1.122	2018398-3	2065038-1, 1934970-1, 2065478-1

* Reference Application Specification 114-13243.

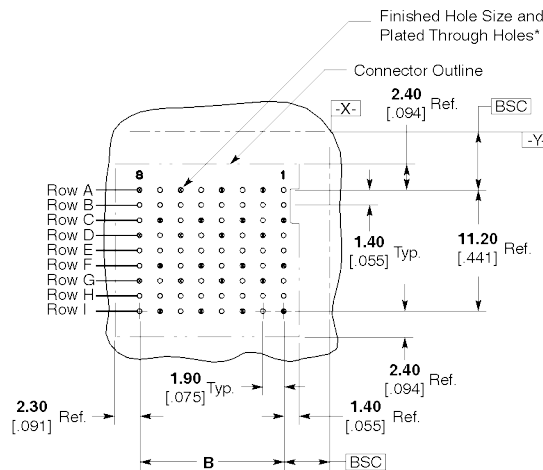
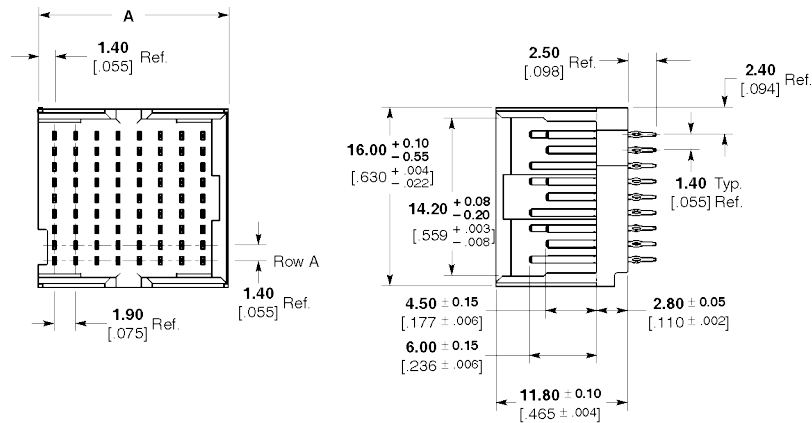

Recommended PC Board Layout
Component Side Shown

Note: For additional information on pcb routing guidelines, reference the Z-PACK TinMan Connector Routing Guide Report #27GC001-1.

* Finished Hole Diameter = 0.46 ± 0.05 [0.018 ±0.002]
 Drilled Hole Diameter = 0.55 ± 0.02 [0.022 ±0.001]
 Copper Thickness = 0.038 ± 0.013 [0.0015 ±0.0005]
 Tin-Lead Thickness = 0.008 ± 0.004 [0.0003 ±0.0002]
 Finishes other than Tin-Lead, See Appl. Spec. 114-13243

Note: All part numbers are RoHS compliant. Tin-Lead parts are RoHS compliant through exemption for lead in press-fit connectors.

3 Pair Verical Header Assemblies - Double End Walls (85 ohm)

Column	Part Number	Dimension		Application Tooling*	Mates With
		A	B		
8	1934974-1	17.95 .707	13.30 .524	2018398-1	1934811-1, 1934968-1, 2065474-1
10	1934976-1	21.75 .856	17.10 .673	2018398-2	1934951-1, 1934969-1, 2065475-1
16	1934978-1	33.15 1.305	28.50 1.122	2018398-3	2065038-1, 1934970-1, 2065478-1

* Reference Application Specification 114-13243.

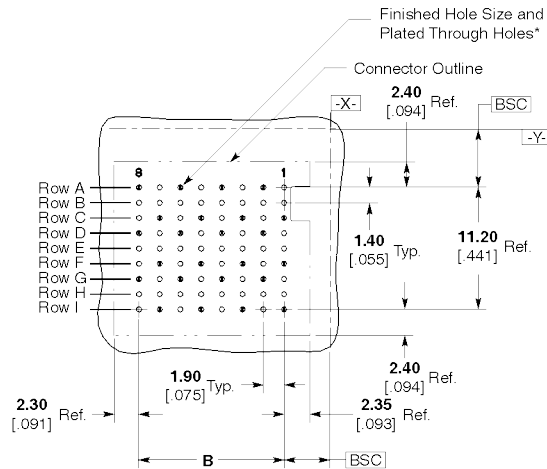
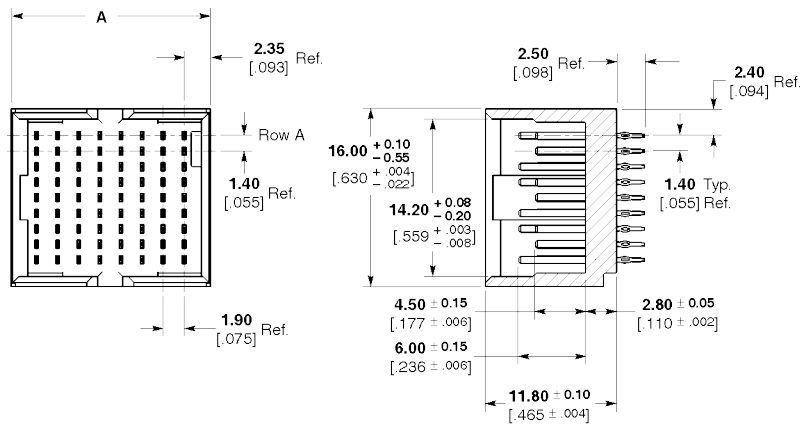

Recommended PC Board Layout
Component Side Shown

Note: For additional information on pcb routing guidelines, reference the Z-PACK TinMan Connector Routing Guide Report #27GC001-1.

* Finished Hole Diameter = 0.46 ± 0.05 [0.018 ± 0.002]
 Drilled Hole Diameter = 0.55 ± 0.02 [0.022 ± 0.001]
 Copper Thickness = 0.038 ± 0.013 [0.0015 ± 0.0005]
 Tin-Lead Thickness = 0.008 ± 0.004 [0.0003 ± 0.0002]
 Finishes other than Tin-Lead, See Appl. Spec. 114-13243

Note: All part numbers are RoHS compliant. Tin-Lead parts are RoHS compliant through exemption for lead in press-fit connectors.

5 Pair Right Angle Pin Header Assemblies (85 ohm)

Column	Part Number	Dimension		Application Tooling	Mates With
		A	B		
8	2065053-1	15.35 .604	13.30 .524	*	1934954-1, 1934949-1, 2065490-1
10	2065027-1	*	*	*	1934932-1, 2065024-1, 2065599-1
16	2065055-1	30.55 1.203	28.50 1.122	*	2065042-1, 1934973-1, 2065493-1

* Custom tooling not required. Utilizes flat-rock insertion tooling.
Reference Application Specification 114-13243.

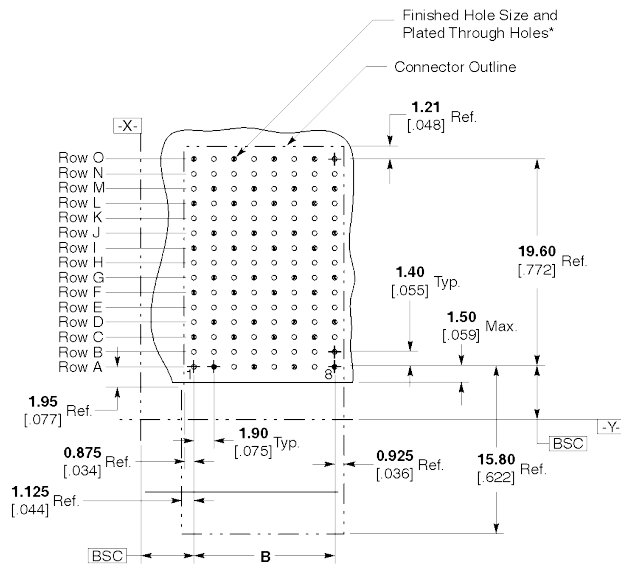
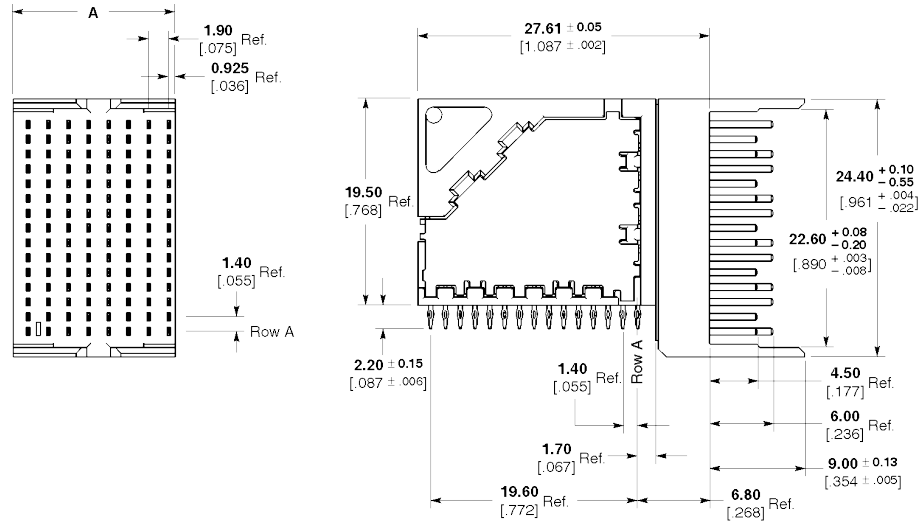

Recommended PC Board Layout
Component Side Shown

Note: For additional information on pcb routing guidelines, reference the Z-PACK TinMan Connector Routing Guide Report #27GC001-1.

* Finished Hole Diameter = 0.46 ± 0.05 [0.018 ± 0.002]
Drilled Hole Diameter = 0.55 ± 0.02 [0.022 ± 0.001]
Copper Thickness = 0.038 ± 0.013 [0.0015 ± 0.0005]
Tin-Lead Thickness = 0.008 ± 0.004 [0.0003 ± 0.0002]
Finishes other than Tin-Lead, See Appl. Spec. 114-13243

Note: All part numbers are RoHS compliant. Tin-Lead parts are RoHS compliant through exemption for lead in press-fit connectors.

5 Pair Right Angle Pin Header Assemblies - Double End Walls (85 ohm)

Column	Part Number	Dimension		Application Tooling	Mates With
		A	B		
8	1934947-1	18.05 [.711]	13.30 [.524]	*	1934954-1, 1934949-1, 2065490-1
10	1934822-1	*	*	*	1934932-1, 2065024-1, 2065599-1
16	2065054-1	33.25 [1.309]	28.50 [1.122]	*	2065042-1, 1934973-1, 2065493-1

* Custom tooling not required. Utilizes flat-rock insertion tooling.
Reference Application Specification 114-13243.

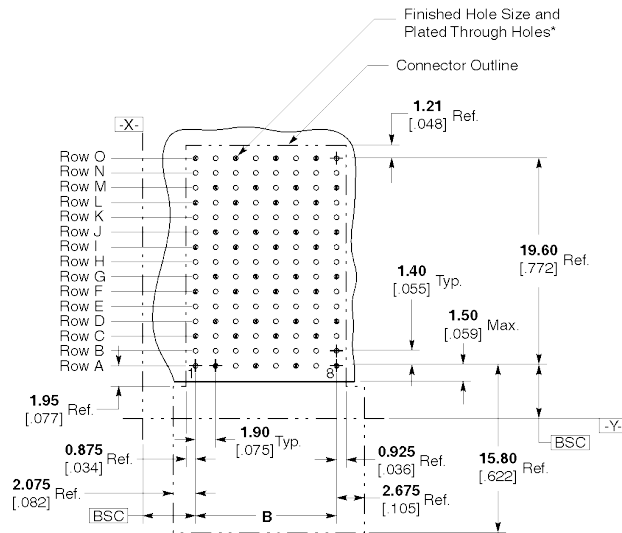
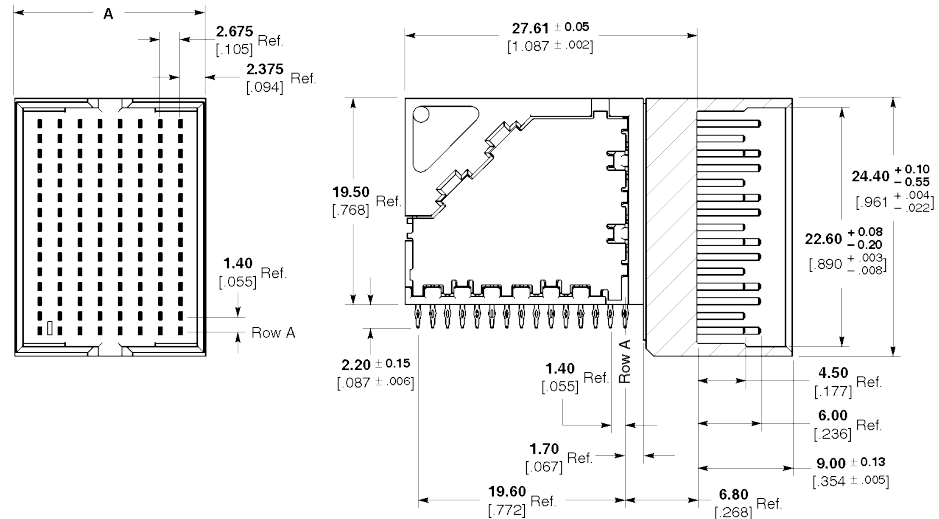

Recommended PC Board Layout Component Side Shown

Note: For additional information on pcb routing guidelines, reference the Z-PACK TinMan Connector Routing Guide Report #27GC001-1.

* Finished Hole Diameter = 0.46 ± 0.05 [0.18 ± 0.002]
 Drilled Hole Diameter = 0.55 ± 0.02 [0.22 ± 0.001]
 Copper Thickness = 0.038 ± 0.013 [0.0015 ± 0.0005]
 Tin-Lead Thickness = 0.008 ± 0.004 [0.0003 ± 0.0002]
 Finishes other than Tin-Lead, See Appl. Spec. 114-13243

Note: All part numbers are RoHS compliant. Tin-Lead parts are RoHS compliant through exemption for lead in press-fit connectors.

3 Pair Right Angle Pin Header Assemblies (85 ohm)

Column	Part Number	Dimension		Application Tooling	Mates With
		A	B		
8	2065043-1	15.35 .604	13.30 .524	*	1934811-1, 1934968-1, 2065474-1
10	2065044-1	19.15 .754	17.10 .673	*	1934951-1, 1934969-1, 2065475-1
16	2065046-1	30.55 1.203	28.50 1.122	*	2065038-1, 1934970-1, 2065478-1

* Custom tooling not required. Utilizes flat-rock insertion tooling.
Reference Application Specification 114-13243.

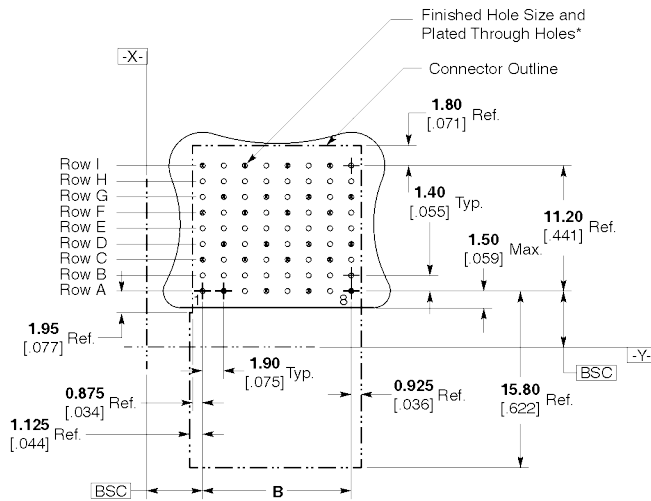
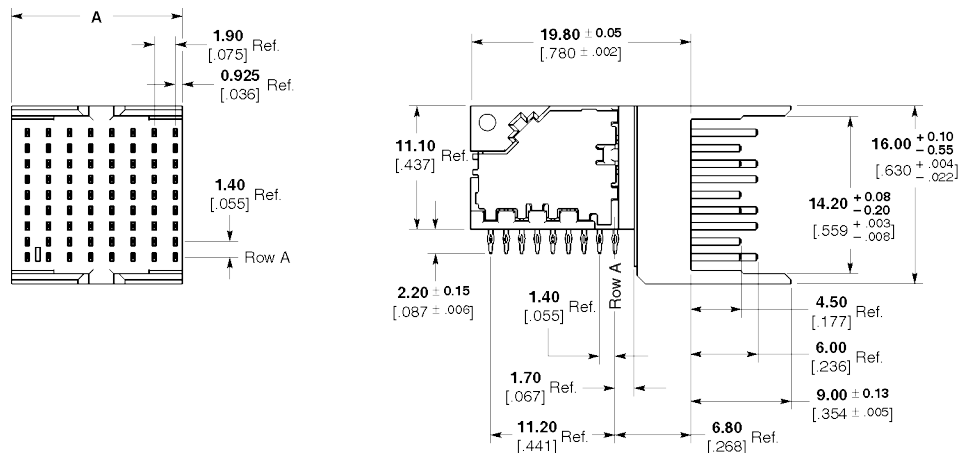

Recommended PC Board Layout
Component Side Shown

Note: For additional information on pcb routing guidelines, reference the Z-PACK TinMan Connector Routing Guide Report #27GC001-1.

* Finished Hole Diameter = 0.46 ± 0.05 [.018 ± .002]
Drilled Hole Diameter = 0.55 ± 0.02 [.022 ± .001]
Copper Thickness = 0.038 ± 0.013 [.0015 ± .0005]
Tin-Lead Thickness = 0.008 ± 0.004 [.0003 ± .0002]
Finishes other than Tin-Lead, See Appl. Spec. 114-13243

Note: All part numbers are RoHS compliant. Tin-Lead parts are RoHS compliant through exemption for lead in press-fit connectors.

3 Pair Right Angle Pin Header Assemblies - Double End Walls (85 ohm)

Column	Part Number	Dimension		Application Tooling	Mates With
		A	B		
8	1934806-1	18.05 [.711]	13.30 [.524]	*	1934811-1, 1934968-1, 2065474-1
10	1934950-1	21.85 [.860]	17.10 [.673]	*	1934951-1, 1934969-1, 2065475-1
16	2065045-1	33.25 [1.309]	28.50 [1.122]	*	2065038-1, 1934970-1, 2065478-1

* Custom tooling not required. Utilizes flat-rock insertion tooling.
Reference Application Specification 114-13243.

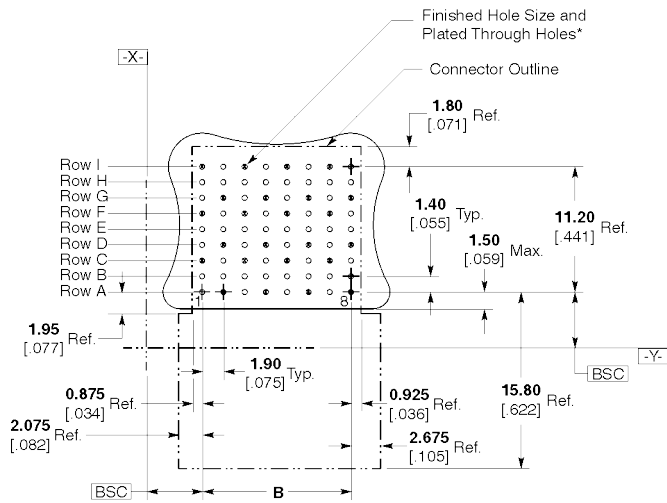
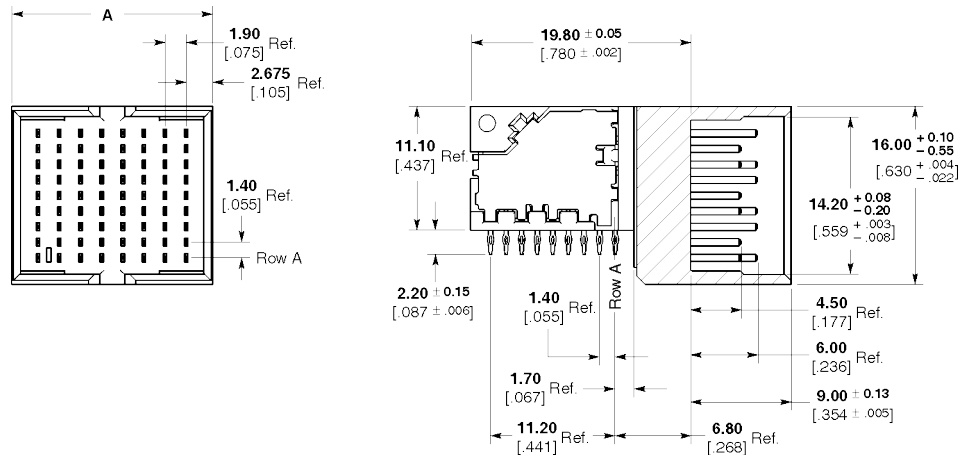

Recommended PC Board Layout
Component Side Shown

Note: For additional information on pcb routing guidelines, reference the Z-PACK TinMan Connector Routing Guide Report #27GC001-1.

* Finished Hole Diameter = 0.46 ± 0.05 [.018 ± .002]
Drilled Hole Diameter = 0.55 ± 0.02 [.022 ± .001]
Copper Thickness = 0.038 ± 0.013 [.0015 ± .0005]
Tin-Lead Thickness = 0.008 ± 0.004 [.0003 ± .0002]
Finishes other than Tin-Lead, See Appl. Spec. 114-13243

Note: All part numbers are RoHS compliant. Tin-Lead parts are RoHS compliant through exemption for lead in press-fit connectors.

Part Number Index

Part No.	Page
1934806-1	3, 17
1934811-1	3, 10, 11, 12, 13, 16, 17
1934822-1	2, 4, 5, 15
1934932-1	2, 6, 7, 8, 9, 14, 15
1934937-1	2, 4, 5, 6
1934947-1	2, 4, 5, 15
1934948-1	2, 4, 5, 9
1934949-1	4, 5, 6, 7, 8, 9, 14, 15
1934950-1	3, 17
1934951-1	3, 10, 11, 12, 13, 16, 17
1934954-1	2, 6, 7, 8, 9, 14, 15
1934957-1	6, 7, 8, 9
1934957-2	6, 7, 8, 9
1934957-4	6, 7, 8, 9
1934968-1	10, 11, 12, 13, 16, 17
1934969-1	10, 11, 12, 13, 16, 17
1934970-1	10, 11, 12, 13, 16, 17
1934973-1	4, 5, 6, 7, 8, 9, 14, 15
1934974-1	3, 13
1934975-1	3, 10
1934976-1	3, 13
1934977-1	3, 10
1934978-1	3, 13
1934979-1	3, 10
1934985-1	2, 4, 5, 6
1934986-1	2, 4, 5, 6
1934987-1	2, 4, 5, 6
2018398-1	10, 11, 12, 13
2018398-2	10, 11, 12, 13
2018398-3	11, 12
2065024-1	4, 6, 7, 8, 9, 14, 15
2065025-1	2, 4, 5, 9
2065027-1	2, 4, 5, 14
2065038-1	3, 10, 11, 12, 13, 16, 17
2065042-1	2, 6, 7, 8, 9, 14, 15
2065043-1	3, 16

Part No.	Page
2065044-1	3, 16
2065045-1	3, 17
2065046-1	3, 16
2065053-1	2, 4, 5, 14
2065054-1	2, 4, 5, 15
2065055-1	2, 4, 5, 14
2065237-1	3
2065239-1	3
2065257-1	3
2065259-1	3
2065305-1	2, 4, 5
2065307-1	2, 4, 5
2065309-1	2, 4, 5
2065311-1	2, 4, 5
2065329-1	2, 4, 5
2065331-1	2, 4, 5
2065474-1	10, 11, 12, 13, 16, 17
2065475-1	10, 11, 12, 13, 16, 17
2065478-1	10, 11, 12, 13, 16, 17
2065490-1	5, 6, 7, 8, 9, 14, 15
2065493-1	5, 6, 7, 8, 9, 14, 15
2065599-1	5, 6, 7, 8, 9, 14, 15
2065704-1	3, 11
2065705-1	3, 12
2065706-1	3, 11
2065707-1	3, 12
2065716-1	3, 11
2065717-1	3, 12
2065738-1	2, 4, 5, 7
2065739-1	2, 3, 5, 8
2065740-1	2, 4, 5, 7
2065741-1	2, 4, 5, 8
2065748-1	2, 4, 5, 7
2065749-1	2, 4, 5, 8
2065790-1	3
2065791-1	3

Note: All part numbers are RoHS compliant.

Tyco Electronics Corporation
Harrisburg, PA

tycoelectronics.com

©2009 Tyco Electronics Corporation
1773455-6 CIS PDF 6/2009

TE logo, Tyco Electronics, Z-PACK and Z-PACK TinMan are trademarks.

While Tyco Electronics Corporation and its affiliates referenced herein ("Tyco Electronics") have made every reasonable effort to ensure the accuracy of the information in this catalog, Tyco Electronics does not guarantee that it is error-free, nor does Tyco Electronics make any other representation, warranty or guarantee that the information is accurate, correct, reliable or current. Tyco Electronics reserves the right to make any adjustments to the information contained herein at any time without notice. Tyco Electronics expressly disclaims all implied warranties regarding the information contained herein, including, but not limited to, any implied warranties of merchantability or fitness for a particular purpose. Tyco Electronics' only obligations are those in the Tyco Electronics Standard Terms and Conditions of Sale, and in no case will Tyco Electronics be responsible for any incidental, indirect, or consequential damages arising from the sale, resale, use, or misuse of its products. Users should independently evaluate the suitability of, and test each product for, their application. The dimensions, specifications, designs, construction, materials and processes in this catalog are for reference purposes only and are subject to change without notice. Please consult Tyco Electronics for the most current product information. The export of certain Tyco Electronics products is restricted by the Arms Export Control Act (Title 22, U.S.C. Sec 2751, et seq.) or the Export Administration Act of 1979, as amended (Title 50, U.S.C., App. 2401 et seq.). Orders may be subject to export approval by the U.S. Government. Buyer must comply with all applicable export laws of all applicable jurisdictions.

X-ON Electronics

Largest Supplier of Electrical and Electronic Components

Click to view similar products for [High Speed/Modular Connectors](#) category:

Click to view products by [TE Connectivity](#) manufacturer:

Other Similar products are found below :

[650827-1](#) [74040-1346](#) [1410191-1](#) [1410368-3](#) [1410964-2](#) [1410326-3](#) [1410367-3](#) [1410971-4](#) [1467833-1](#) [2000877-1](#) [2000878-1](#) [2041314-1](#)
[2065387-1](#) [2187307-1](#) [163P](#) [1934290-1](#) [2000875-1](#) [2065917-1](#) [2102736-2](#) [FSR-40](#) [2169868-2](#) [22354-8](#) [437-5040-000](#) [5-1393565-0](#) [039-](#)
[0246-000](#) [0761601016](#) [0784461022](#) [10123159-12ELF](#) [030-2415-003/100 PK](#) [030-7380-004](#) [030-2494-001](#) [532939-1](#) [5532901-3](#) [3-1469268-](#)
[7](#) [74748-102LF](#) [73670-0247](#) [10041743-101LF](#) [10066670-100002LF](#) [1-533915-1](#) [249-4515-000](#) [7-1469373-3](#) [DL2-2J/S](#) [2000713-8](#)
[2000713-7](#) [10124313-101LF](#) [3011-21](#) [757105208](#) [EBTF-4-10-2.0-S-RA-1](#) [430305-001](#) [4395800100](#)