

ITEM DESCRIPTION	APPLICABLE COMPONENTS				APPLICABLE WIRE TYPE AND SIZE					
	COLOUR / PLATING	FORD COMP. PART	SIEMENS COMP. PART	MATERIAL / SPEC. NO.	EAO			NAAO		
					WIRE SIZE	LOW TEMP.	HIGH TEMP.	WIRE SIZE	LOW TEMP.	HIGH TEMP.
Male Pin	GOLD	1L2T-14A21-DA	V23540-X7000-Y30	COPPER ALLOY / N/A	0,22 / 0,35	WSK-MIL124-A	S97GG-14A01-AA	AWG22	WSB-MIL134-A1	WSS-MIL135-A1
Male Pin	TIN	1L2T-14A21-BA	V23540-X7000-Y31	COPPER ALLOY / N/A	0,22 / 0,35	WSK-MIL124-A	S97GG-14A01-AA	AWG22	WSB-MIL134-A1	WSS-MIL135-A1
Male Pin	GOLD	1L2T-14A21-CA	V23540-X7000-Y40	COPPER ALLOY / N/A	0,5 / 0,75	WSK-MIL124-A	S97GG-14A01-AA	AWG20	ESB-MIL120-A	ESB-MIL123-A/AZ
								AWG18	WSB-MIL134-A1	WSS-MIL135-A1
								AWG20	WSB-MIL134-A1	WSS-MIL135-A1
Male Pin	TIN	1L2T-14A21-AA	V23540-X7000-Y41	COPPER ALLOY / N/A	0,5 / 0,75	WSK-MIL124-A	S97GG-14A01-AA	AWG20	ESB-MIL120-A	ESB-MIL123-A/AZ
								AWG18	WSB-MIL134-A1	WSS-MIL135-A1

- NOTES:
- PART MUST CONFORM TO THE ELECTRICAL CONNECTION SYSTEM DESIGN SPECIFICATION (SDS) REV.14, dated 97209
 - PART MUST CONFORM ES-FR00-14A64-AA (USCAR) dated 95011
 - MAXIMUM INSERTION FORCE FULLY POPULATED WITH TIN TERMINALS IS LESS THAN OR EQUAL TO 90N
 - ALL PLASTIC PARTS MUST HAVE MATERIAL IDENTIFICATION SYMBOLS CLEARLY MARKED, WHEREVER PACKAGE SIZE PERMITS
 - ENGINEERING APPROVAL REQUIRED FOR ALL SOURCING AND TOOLING OF THIS PART
 - FOR ENGINEERING APPROVED SOURCE SEE ENGINEERING RELEASE
 - ENGINEERING APPROVAL OF SAMPLE FROM EACH SUPPLIER IS REQUIRED PRIOR TO AUTHORIZATION OF PART PRODUCTION
 - CHANGES IN DESIGN COMPOSITION OR PROCESSING FROM THE PART PREVIOUSLY APPROVED FOR PART PRODUCTION REQUIRES PRIOR ENGINEERING APPROVAL
 - GENERAL TOLERANCES: ±0.3 ALL ONE PLACE DIMENSIONS, ±0.19 ALL TWO PLACE DIMENSIONS, ±3°00' ALL ANGULAR DIMENSIONS
 - PART MUST MATE WITH TBD
 - 0.2mm MAXIMUM RADIUS PERMISSIBLE ON EDGES AND FILLETS SHOWN AS SHARP FOR PLASTIC PARTS
 - X.XX DENOTES BASIC DIMENSIONS. BASIC DIMENSIONS HAVE ZERO TOLERANCES AND DESCRIBE THE EXACT THEORETICAL LOCATION (TRUE POSITION) OR CONTOUR
 - DENOTES TOLERANCE ZONE IN A RELATION TO A FEATURE
 - DENOTES GAGE DESIGN. GAGE DESIGNS MUST HAVE SIGNED ENGINEERING APPROVAL PRIOR TO CONSTRUCTION AND WILL BE A CONDITION OF FINAL PART APPROVAL
 - PARTS ARE TO BE FREE OF SCRATCHES, DISCOLORATION, SALT RESIDUE OR OTHER IMPERFECTIONS THAT MAY AFFECT FUNCTION OR FIT OF PART
 - SOURCE IDENTIFICATION MARK, PRODUCTION DATE CODE & ASSEMBLY PART NO. MUST BE PERMANENTLY APPLIED ON THE PART THE MASTER SOURCE OF INFORMATION FOR THIS DRAWING IS IN A PC COMPUTER DATABASE. CHANGES ARE NOT PERMITTED WITHOUT PRIOR CONSENT OF RELEVANT ENGINEERING CAD ACTIVITY

REVISIONS			
ORIGINATOR	CHECKER	ENGR APP	MATL APP
Released			
EEOO 1 10959705 000	DATE: 980407	CAD:Y	
B. HULPIAU	DSCHIMAN	FSENYUEZ	SIEMENS EC
① RIBS ADDED			
② DIM. 3,2±0,15 ADDED			
DATE: 980914 CAD:Y			
V. CAUWENB.	DSCHIMAN	FSENYUEZ	SIEMENS EC

ITEM	DESCRIPTION	COLOUR	FORD COMP. PART	SIEMENS COMP. PART	MATERIAL RECYCLING CODE	WEIGHT	No. OF ITEMS REQUESTED
1	MALE HOUSING CODE A	BLACK	N/A	C23372-A40-C02	LCP GF30	8,95	
2	MALE HOUSING CODE B	GREEN	N/A	C23372-A40-C03	LCP GF30	8,95	
3	MALE HOUSING CODE C	NATURAL	N/A	C23372-A40-C04	LCP GF30	8,95	
4	MALE SPACER	RED	N/A	C23372-A49-C73	LCP GF30	0,82	

FORD PART	SIEMENS PART	MAX TEMP.	FORD PART	SIEMENS PART
IS7T-14A459-SA	V23542-G2422-D101	145°C	IS7T-14A89-SA	V23542-G2622-D101
IS7T-14A459-TA	V23542-G2422-D102	145°C	IS7T-14A89-TA	V23542-G2622-D102
IS7T-14A459-VA	V23542-G2422-D103	145°C	IS7T-14A89-VA	V23542-G2622-D103

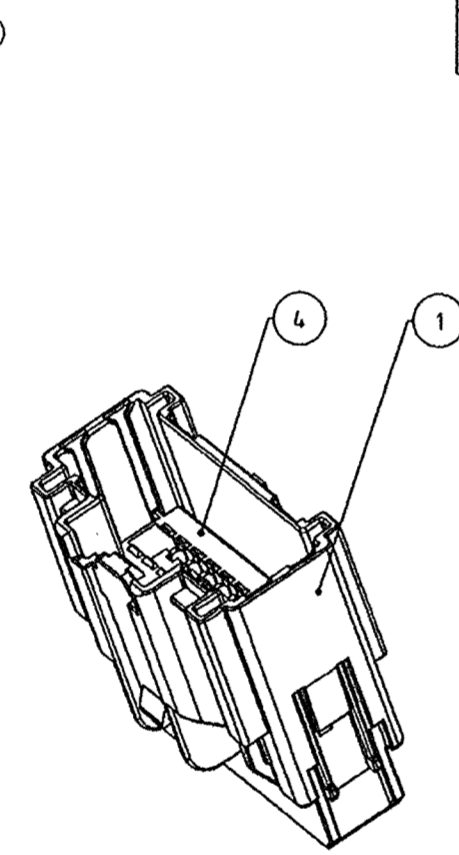
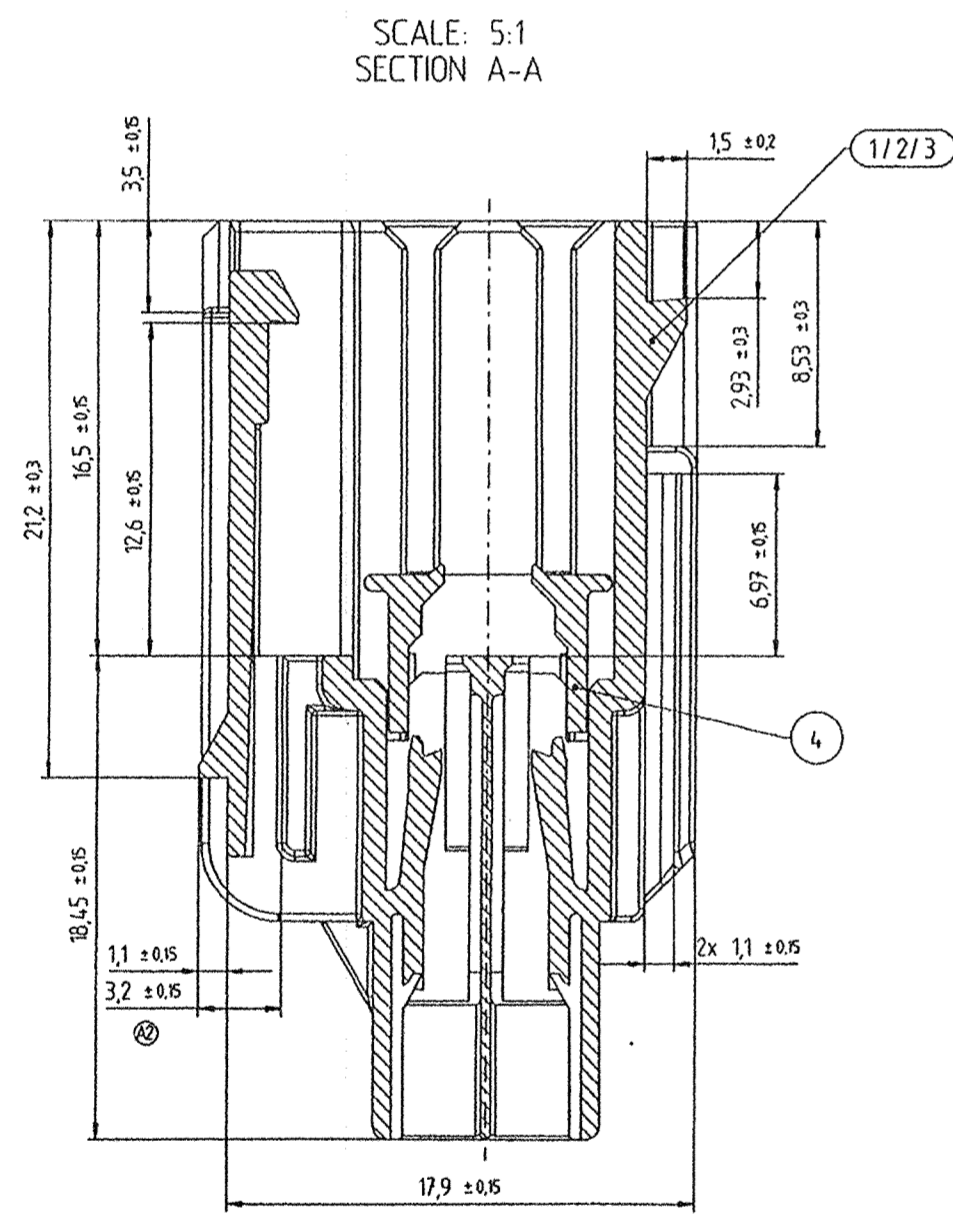

FORD PART NUMBER:
IS7T-14A459-SA
CODE A

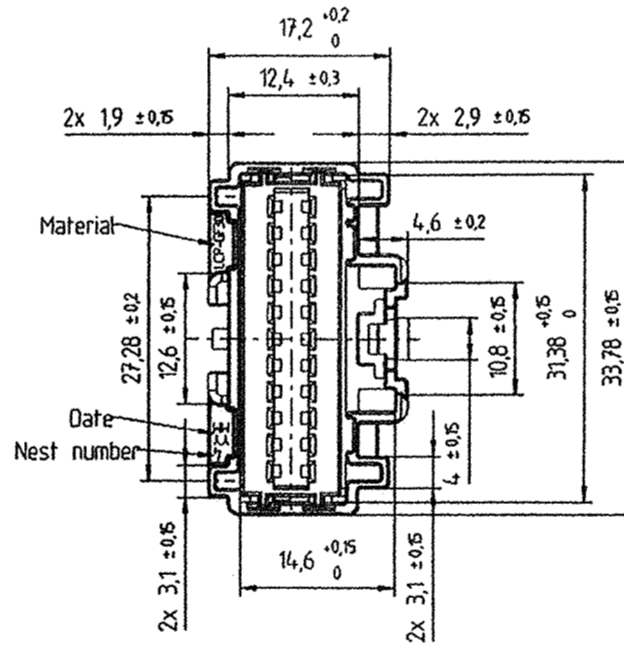
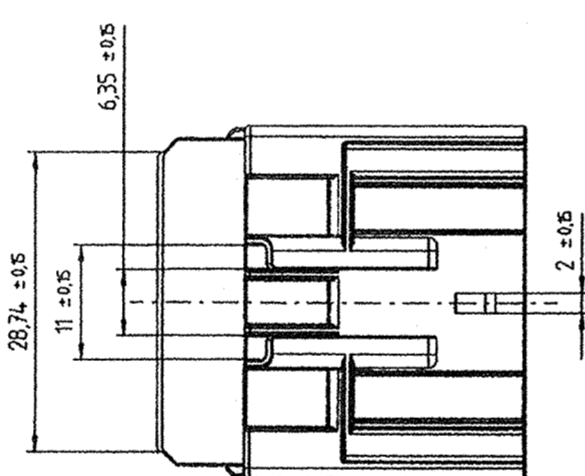
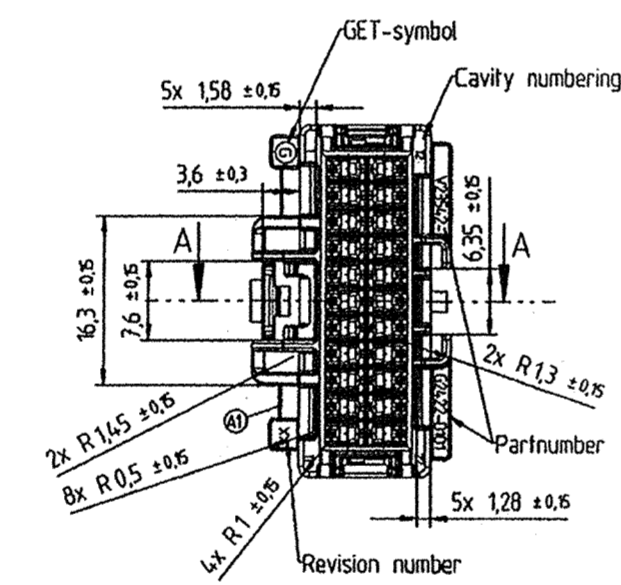

DELIVERY CONDITION:
SPACER IN PREINSTALLED POSITION

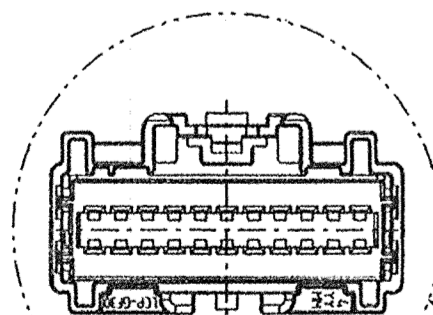

Ø 41
MIN. FEED THROUGH CONDITION
(2mm CLEARANCE ALL THE WAY
AROUND INCLUDED)
KEYING OPTION 1

	CODE A COLOUR: BLACK	CODE B COLOUR: GREEN	CODE C COLOUR: NATURAL
SIEMENS PART	V23542-G2422-D101	V23542-G2422-D102	V23542-G2422-D103
FORD PART	IS7T-14A459-SA	IS7T-14A459-TA	IS7T-14A459-VA
	14,3 ±0,1 12,8 ±0,1	12,8 ±0,1 14,3 ±0,1	12,8 ±0,1 12,8 ±0,1
SIEMENS PART	V23542-G2622-D101	V23542-G2622-D102	V23542-G2622-D103
FORD PART	IS7T-14A89-SA	IS7T-14A89-TA	IS7T-14A89-VA

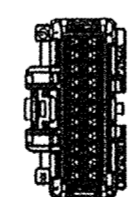
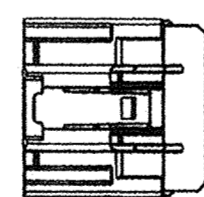
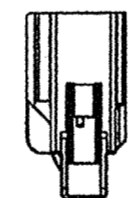
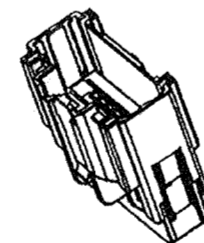

FULL SIZE VIEWS
SCALE: 1:1

IS7T-14A459-TA
IS7T-14A459-VA

THIS DRAWING HAS BEEN PREPARED BY OR ON BEHALF OF FORD MOTOR COMPANY. FORD RETAINS ALL COMMON LAW, STATUTORY AND OTHER RESERVED RIGHTS, INCLUDING COPYRIGHTS. THIS DRAWING SHALL NOT BE USED FOR ANY PURPOSE OTHER THAN PERFORMING SERVICES DIRECTLY OR INDIRECTLY TO FORD, WITHOUT THE EXPRESSED WRITTEN PERMISSION OF FORD. UNAUTHORIZED USE, COPYING OR MODIFICATION, INCLUDING THE REMOVAL OF THIS NOTE, MAY CONSTITUTE A VIOLATION OF CIVIL OR CRIMINAL LAWS ENFORCEABLE BY FORD OR GOVERNMENTAL AGENCIES.

COPYRIGHT © FORD MOTOR COMPANY
(YEAR AS INITIAL RELEASE)

SIEMENS		OSMAN SYLVANIA	
SIEMENS DRAWING NR.	V23542-G2422-D101-D103-05-7427	SIEMENS DRAWING NR.	
REFERENCE	MP-1571-180101-083	SIEMENS DRAWING NR.	
PART MUST COMPLY WITH MATERIAL SPECIFICATION WSS-H99P9899-A1 TO HELP SAFEGUARD HEALTH, SAFETY AND THE ENVIRONMENT.		SIEMENS DRAWING NR.	
DRAFTED IN ACCORDANCE WITH FAO ENGINEERING DRAFTING STANDARD CURRENT AT INITIAL RELEASE		SIEMENS DRAWING NR.	
CAD TYPE	S-IDEAS	CAD FILE	157T-14A459-S ; VER 5
OPER. NO.	UNIT	DRAWING	IS MASTER
DESIGN	DETAIL	TITLE	SLV ASY-WIRE CONNECTOR - MALE
CHECKED	SAFETY		SHT 1 OF 1
SCALE	DATE	DIVISION	PLANT
2:1	980517		

NOTE:
1. DIMENSIONING AND TOLERANCING PER ASME Y14.5M-1994.
WITH EXCEPTIONS AS DESCRIBED IN DRAWING STANDARDS.

Weltergabe sollte Vervielfältigung dieser Unterlagen, Vereinerung und Mittelung ohne Erlaubnis nicht gestattet, soweit nicht ausdrücklich festgesetzt.
Zur Übertragung von Informationen zu Sicherheitsrisiko. Alle Rechte vorbehalten.
Inhaber der Rechte an der Patenterteilung oder der Erfindung.
The reproduction, transmission or use of this document or its contents is not permitted without express written authority. Offenders will be liable for damages.
All rights, including copyright, are reserved by the patent holder or its assignee.

REV.	DESCRIPTION	DATE	BY	CHKD.
01	23.12.98 JWA	26.11.98		
02	18.05.99 BH			
03	18.05.99 BH			
04	18.05.99 BH			
05	18.05.99 BH			
06	18.05.99 BH			
07	18.05.99 BH			
08	18.05.99 BH			
09	18.05.99 BH			
10	18.05.99 BH			
11	18.05.99 BH			
12	18.05.99 BH			
13	18.05.99 BH			
14	18.05.99 BH			
15	18.05.99 BH			
16	18.05.99 BH			
17	18.05.99 BH			
18	18.05.99 BH			
19	18.05.99 BH			
20	18.05.99 BH			
21	18.05.99 BH			
22	18.05.99 BH			
23	18.05.99 BH			
24	18.05.99 BH			
25	18.05.99 BH			
26	18.05.99 BH			
27	18.05.99 BH			
28	18.05.99 BH			
29	18.05.99 BH			
30	18.05.99 BH			
31	18.05.99 BH			
32	18.05.99 BH			
33	18.05.99 BH			
34	18.05.99 BH			
35	18.05.99 BH			
36	18.05.99 BH			
37	18.05.99 BH			
38	18.05.99 BH			
39	18.05.99 BH			
40	18.05.99 BH			
41	18.05.99 BH			
42	18.05.99 BH			
43	18.05.99 BH			
44	18.05.99 BH			
45	18.05.99 BH			
46	18.05.99 BH			
47	18.05.99 BH			
48	18.05.99 BH			
49	18.05.99 BH			
50	18.05.99 BH			
51	18.05.99 BH			
52	18.05.99 BH			
53	18.05.99 BH			
54	18.05.99 BH			
55	18.05.99 BH			
56	18.05.99 BH			
57	18.05.99 BH			
58	18.05.99 BH			
59	18.05.99 BH			
60	18.05.99 BH			
61	18.05.99 BH			
62	18.05.99 BH			
63	18.05.99 BH			
64	18.05.99 BH			
65	18.05.99 BH			
66	18.05.99 BH			
67	18.05.99 BH			
68	18.05.99 BH			
69	18.05.99 BH			
70	18.05.99 BH			
71	18.05.99 BH			
72	18.05.99 BH			
73	18.05.99 BH			
74	18.05.99 BH			
75	18.05.99 BH			
76	18.05.99 BH			
77	18.05.99 BH			
78	18.05.99 BH			
79	18.05.99 BH			
80	18.05.99 BH			
81	18.05.99 BH			
82	18.05.99 BH			
83	18.05.99 BH			
84	18.05.99 BH			
85	18.05.99 BH			
86	18.05.99 BH			
87	18.05.99 BH			
88	18.05.99 BH			
89	18.05.99 BH			
90	18.05.99 BH			
91	18.05.99 BH			
92	18.05.99 BH			
93	18.05.99 BH			
94	18.05.99 BH			
95	18.05.99 BH			
96	18.05.99 BH			
97	18.05.99 BH			
98	18.05.99 BH			
99	18.05.99 BH			
100	18.05.99 BH			

REV.	DESCRIPTION	DATE	BY	CHKD.
01	23.12.98 JWA	26.11.98		
02	18.05.99 BH			
03	18.05.99 BH			
04	18.05.99 BH			
05	18.05.99 BH			
06	18.05.99 BH			
07	18.05.99 BH			
08	18.05.99 BH			
09	18.05.99 BH			
10	18.05.99 BH			
11	18.05.99 BH			
12	18.05.99 BH			
13	18.05.99 BH			
14	18.05.99 BH			
15	18.05.99 BH			
16	18.05.99 BH			
17	18.05.99 BH			
18	18.05.99 BH			
19	18.05.99 BH			
20	18.05.99 BH			
21	18.05.99 BH			
22	18.05.99 BH			
23	18.05.99 BH			
24	18.05.99 BH			
25	18.05.99 BH			
26	18.05.99 BH			
27	18.05.99 BH			
28	18.05.99 BH			
29	18.05.99 BH			
30	18.05.99 BH			
31	18.05.99 BH			
32	18.05.99 BH			
33	18.05.99 BH			
34	18.05.99 BH			
35	18.05.99 BH			
36	18.05.99 BH			
37	18.05.99 BH			
38	18.05.99 BH			
39	18.05.99 BH			
40	18.05.99 BH			
41	18.05.99 BH			
42	18.05.99 BH			
43	18.05.99 BH			
44	18.05.99 BH			
45	18.05.99 BH			

X-ON Electronics

Largest Supplier of Electrical and Electronic Components

Click to view similar products for [Automotive Connectors](#) category:

Click to view products by [TE Connectivity](#) manufacturer:

Other Similar products are found below :

[003-018-000](#) [60403001](#) [60993906-B](#) [M902-2131](#) [M902-2161](#) [72.330.1035.1](#) [73.353.4028.0](#) [F119300-B](#) [F166900](#) [F258300-B](#) [F358300-B](#)
[F407400](#) [F444110](#) [F487000](#) [F509500B-B](#) [827153-1](#) [8N1515-32-24P](#) [9-1326729-8](#) [925474-1](#) [928905-1](#) [964562-4](#) [968782-1](#) [GT17SA-8DS-](#)
[HU](#) [98891-1012](#) [98947-1016](#) [12004147](#) [12004475-L](#) [12010290](#) [12010309-B](#) [12015454](#) [12020219-B](#) [12020308](#) [12041318-B](#) [12052225-L](#)
[12052466](#) [12059125](#) [12064869](#) [12004327-B](#) [12010503-B](#) [12015308](#) [12015384](#) [12015909](#) [1-21030-1](#) [12041254](#) [12041318](#) [12047946-B](#)
[12047957](#) [12047957-L](#) [12059473](#) [12066261](#)