

LOC	DIST	REVISIONS					
		P	LTN	DESCRIPTION	DATE	DWN	APVD
GP	00	6		REVISED PER ECO-12-003841	14MAR2012	TY	KS
		7		REVISED PER ECO-12-005533	05APR2012	JY	AC
		A		REVISED PER ECR-13-019963	5NOV2013	RG	MC
		B		REVISED PER ECO-14-016878	30EC2014	RG	MC

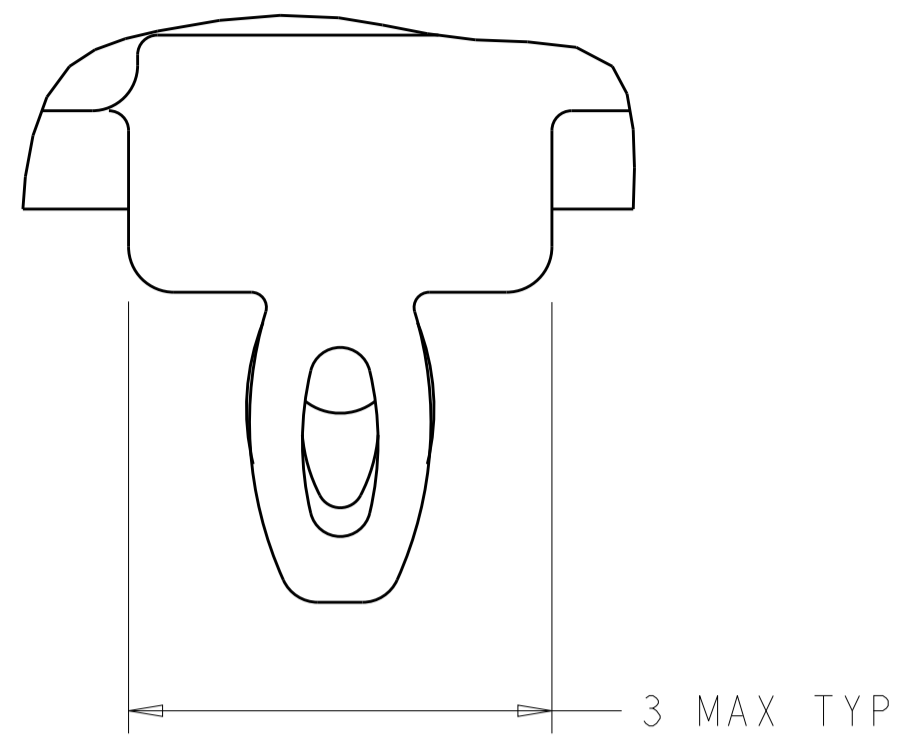

DETAIL S
 SCALE 20:1

- ⚠ CAGE ASSEMBLY MATERIAL: NICKEL SILVER, 0.25 THICK
 HEAT SINK MATERIAL: ALUMINUM/NICKLE PLATING
 HEAT SINK CLIP MATERIAL: STAINLESS STEEL
 EMI SPRING MATERIAL: COPPER ALLOY
 FRONT FLANGE MATERIAL: ZINC ALLOY
 LIGHT PIPE MATERIAL: CLEAR POLYCARBONATE
- ② PITCH BETWEEN PORTS OF ONE 1X6 CAGE ASSEMBLY.
- ③ SPACING BETWEEN CAGES ON THE SAME PC BOARD, TO BE SPECIFIED BY CUSTOMER, MUST COMPLY WITH MINIMUM DIMENSIONS SHOWN.
- ④ REFERENCE APPLICATION SPEC 114-13218 FOR RECOMMENDED DRILL HOLE DIAMETER AND PLATING THICKNESS.
- ⑤ DATUMS AND BASIC DIMENSIONS ESTABLISHED BY CUSTOMER.
- ⑥ DIMENSION F IS THE NOMINAL THICKNESS OF CUSTOMER SUPPLIED PC BOARD,
 SINGLE SIDED PC BOARD MINIMUM THICKNESS = 1.45mm
 DOUBLE SIDED PC BOARD MINIMUM THICKNESS = 2.2mm PER QSFP.
- ⑦ HEAT SINKS, LIGHT PIPES, AND HEAT SINK CLIPS SHIPPED ASSEMBLED TO CAGE ASSEMBLY. CAGE ASSEMBLY MAY BE PRESSED INTO THE PCB AS SHIPPED.
- ⑧ DATUM A IS TOP SURFACE OF PC BOARD.
- ⑨ DIMENSION APPLIES WITH MODULE INSERTED IN CAGE.
- ⑩ UNPLATED THRU HOLE.
- 11. MATES WITH QSFP MSA COMPATIBLE TRANSCEIVER.
- ⑫ SURFACE TRACES PERMITTED WITHIN THIS AREA EXCEPT WHERE CAGE STANDOFFS, SHOWN IN DETAIL S, CONTACT PC BOARD.
- ⑬ BASELINE FOR THESE DIMENSIONS IS THE CENTER OF COMPLIANT PIN HOLE.
- ⑭ 2D BARCODE AND DATE CODE (YYWW) MARKED ON SIDE OF CAGE ASSEMBLY.

- ⑮ REFERENCE APP SPEC 114-13218 FOR GASKET THICKNESS CALCULATION.
- ⑯ EMI SPRING FINISH: 2um MINIMUM TIN
 FRONT FLANGE FINISH: 3um MINIMUM TIN OVER 1.27um MINIMUM NICKEL OVER 5.08um MINIMUM COPPER.
- ⑰ HEAT SINKS AND CLIPS SHIPPED ASSEMBLED TO CAGE ASSEMBLY. CAGE ASSEMBLY MAY BE PRESSED INTO THE PCB AS SHIPPED. LIGHT PIPES, SHIPPED UNATTACHED, MUST BE ASSEMBLED BY CUSTOMER AFTER THE CAGE IS SEATED IN THE PCB.
- ⑱ ROUND LIGHT PIPES PLEASE SEE SHEET 4/6
- ⑲ HEAT SINK FINISH: BLACK ANODIZED

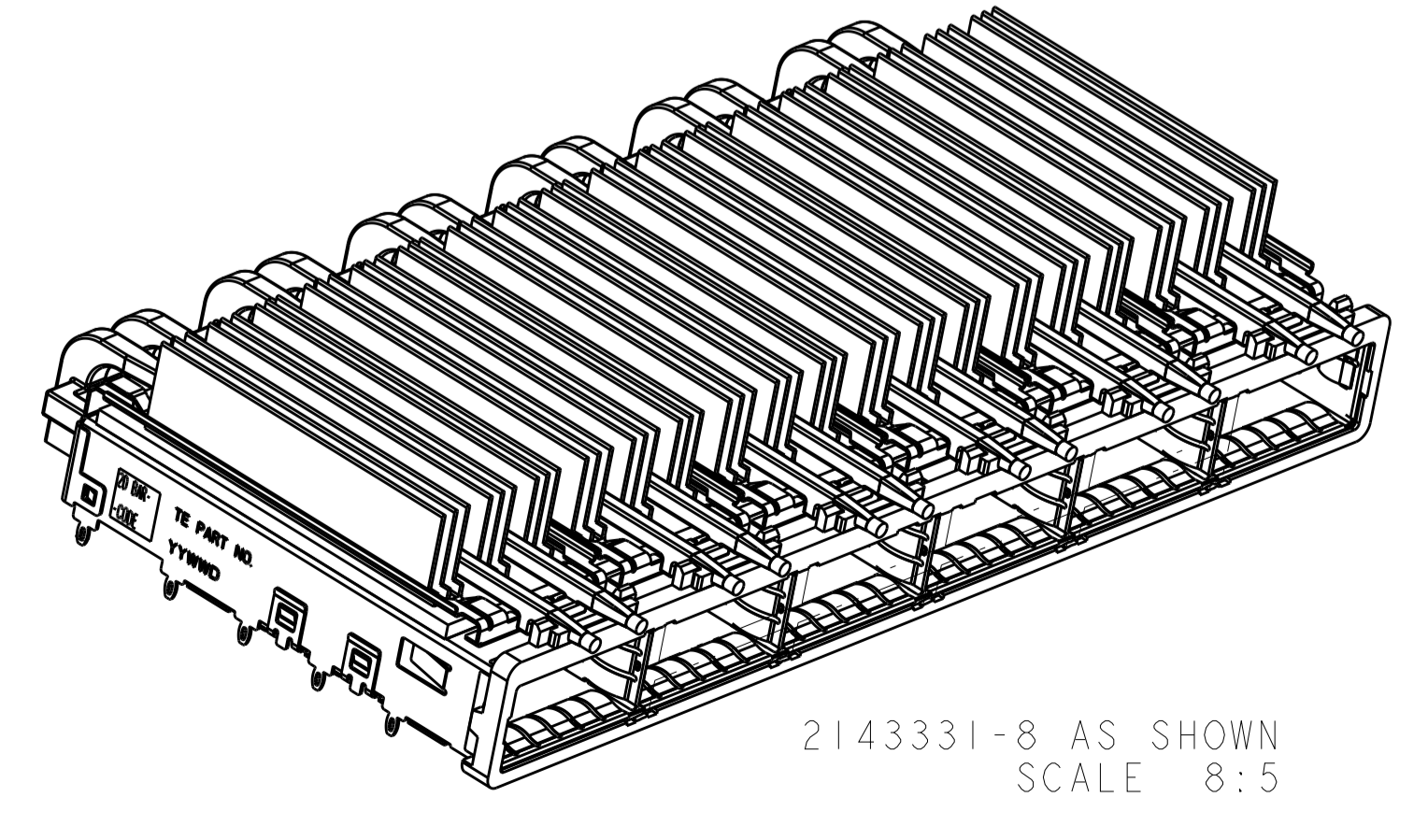
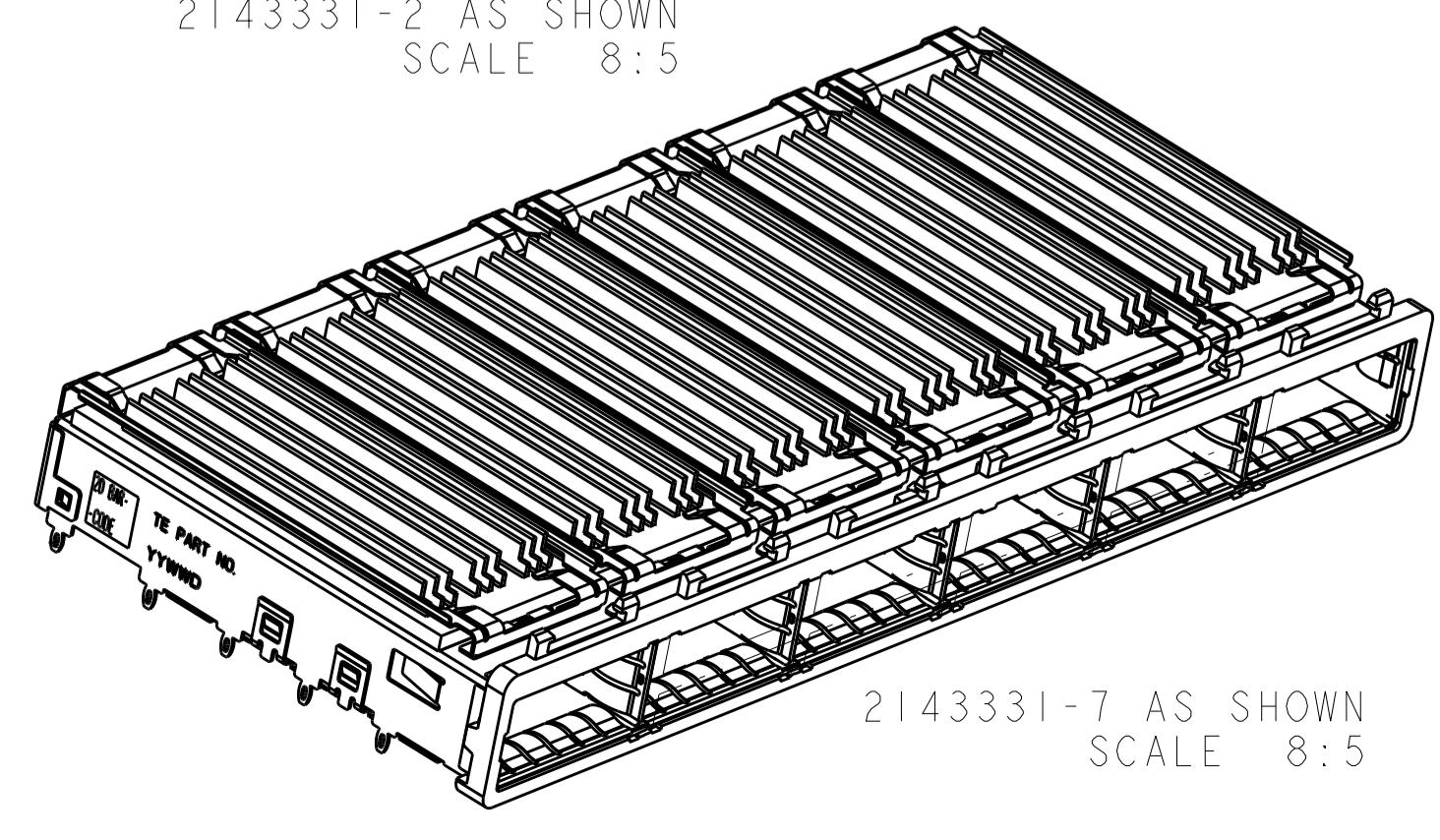
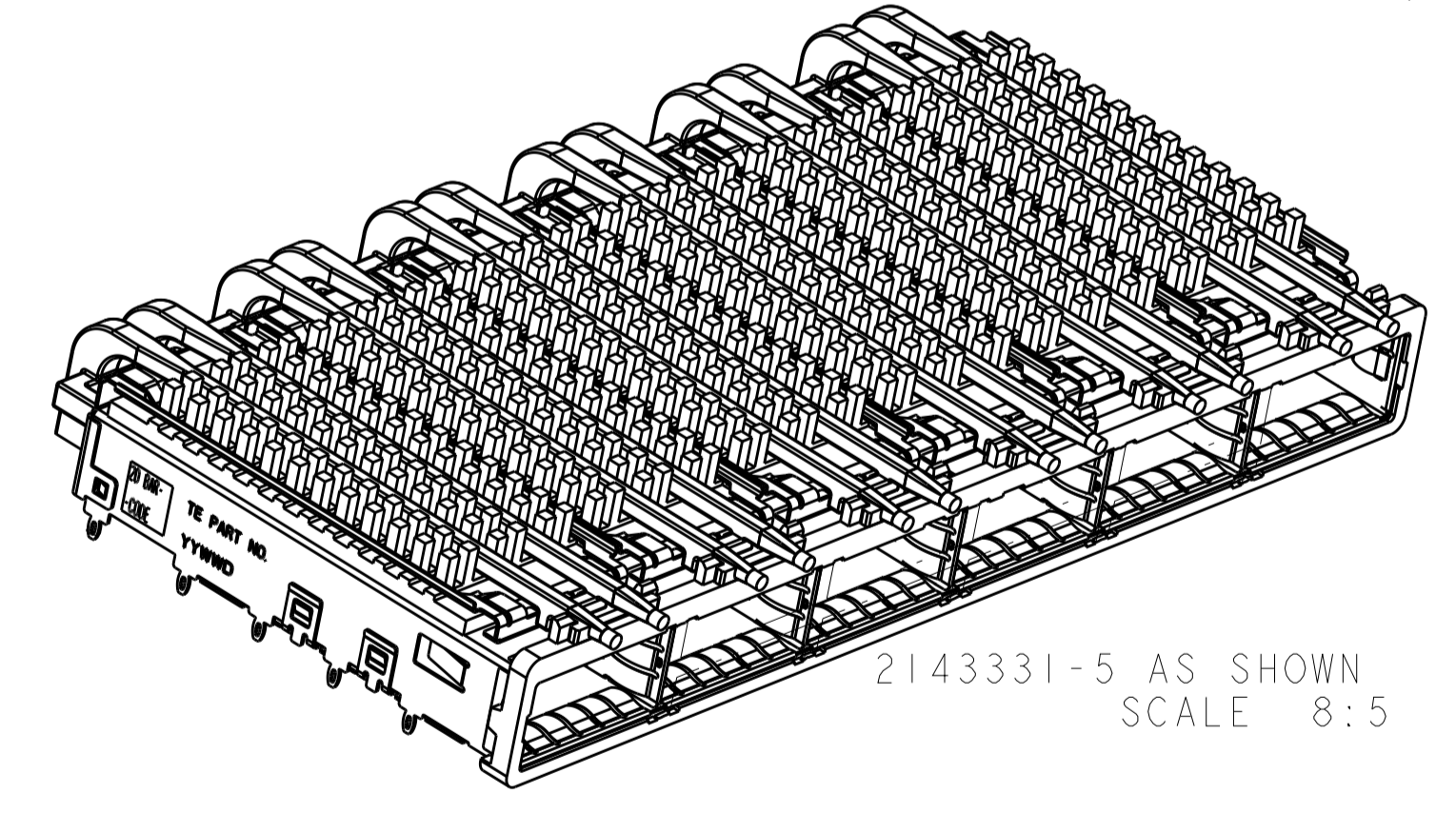
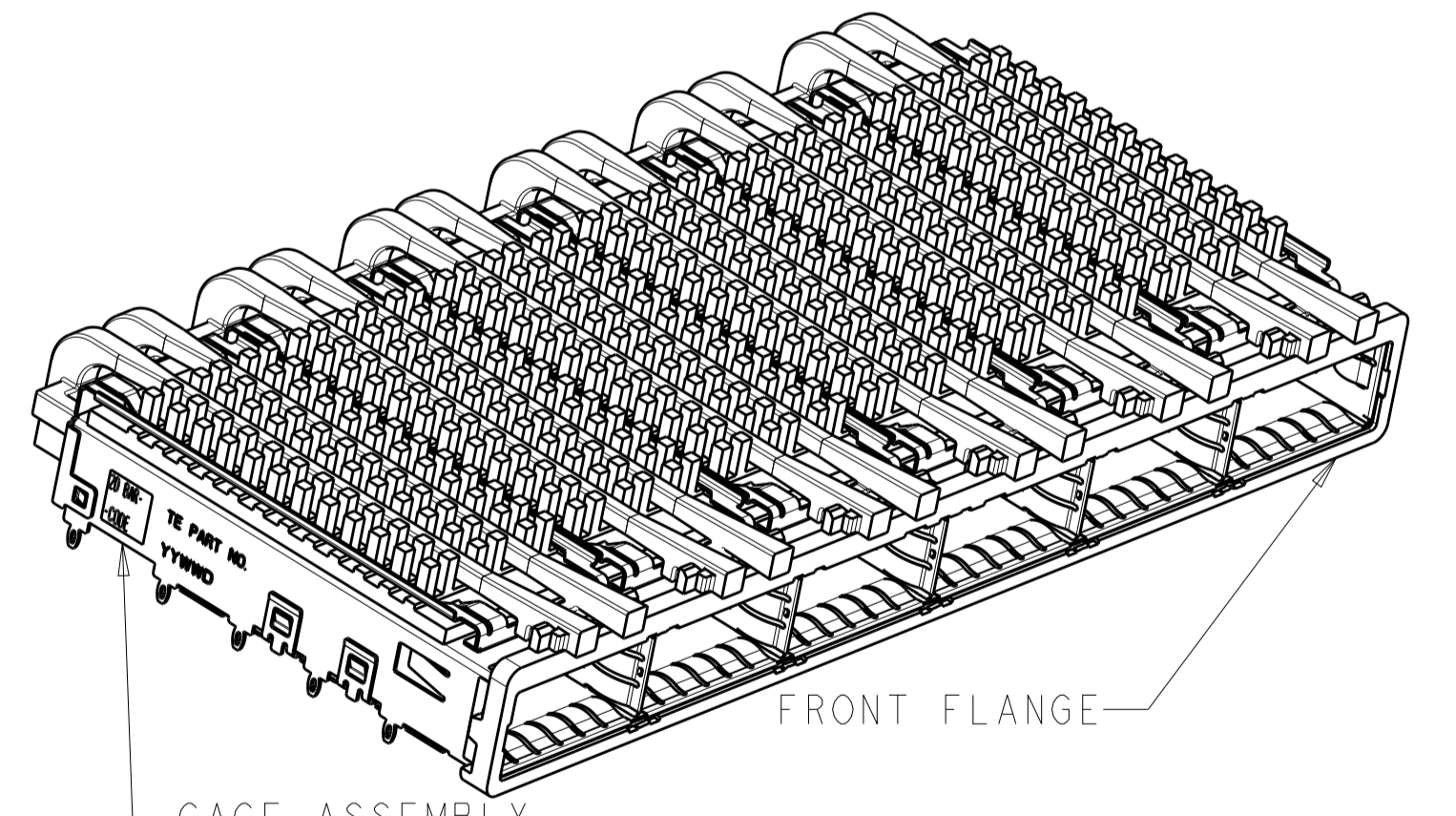
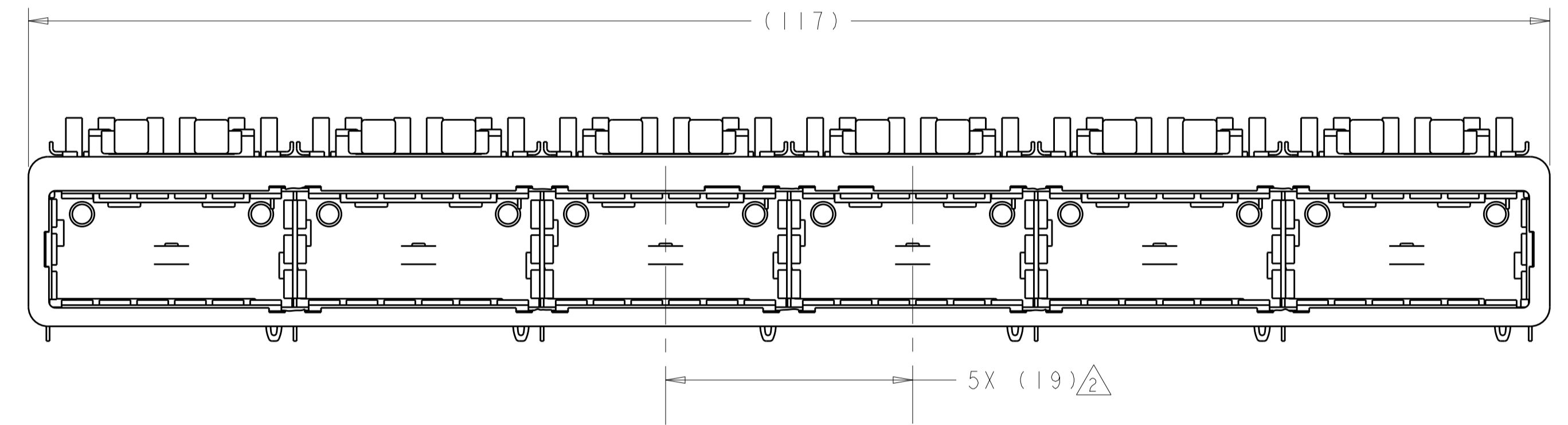
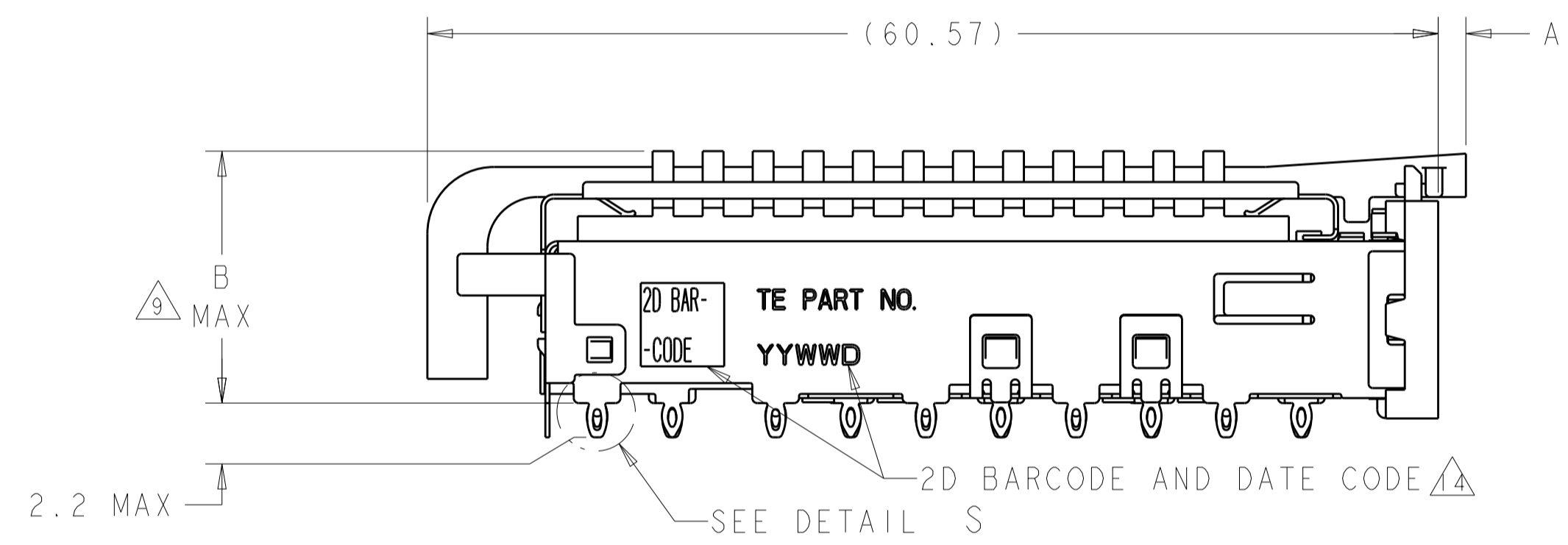

⑮	⑯	⑰	⑱	⑲	⑳
ROUND LIGHT PIPE	2.00	21.0	FIN TYPE	2143331-8	
N/A	N/A	15.0	FIN TYPE	2143331-7	
ROUND LIGHT PIPES	1.66	23.0	NETWORKING	2143331-6	
		16.0	SAN	2143331-5	
		13.7	PCI	2143331-4	
SQUARE LIGHT PIPES	1.66	23.0	NETWORKING	2143331-3	
		16.0	SAN	2143331-2	
		13.7	PCI	2143331-1	
LIGHT PIPE TYPE	A	B	HEAT SINK PROFILE	PART NUMBER	

THIS DRAWING IS A CONTROLLED DOCUMENT. DWN: C. VALENTINE 18MAR2010
 CHK: J. PETERSON 18MAR2010
 APVD: J. PETERSON 18MAR2010

DIMENSIONS: mm
 0 PLC ±0.20
 1 PLC ±0.15
 2 PLC ±0.15
 3 PLC ±0.15
 4 PLC ±0.15
 ANGLES ±0.15

TOLERANCES UNLESS OTHERWISE SPECIFIED:

MATERIAL: FINISH: ⑰

Customer Drawing

NAME: 1X6 CAGE ASSEMBLY, BEHIND BEZEL, W/ SQP LIGHT PIPES AND HEAT SINKS, QSFP
 PRODUCT SPEC: 108-2286
 APPLICATION SPEC: 114-13218
 WEIGHT: -

SIZE: A1
 CAGE CODE: 00779
 DRAWING NO: 2143331
 RESTRICTED TO: -

SCALE: 3:1 SHEET 1 OF 6 REV: B1

LOC	DIST	REVISIONS			
P	LTN	DESCRIPTION	DATE	DWN	APVD
-	-	SEE SHEET 1	-	-	-

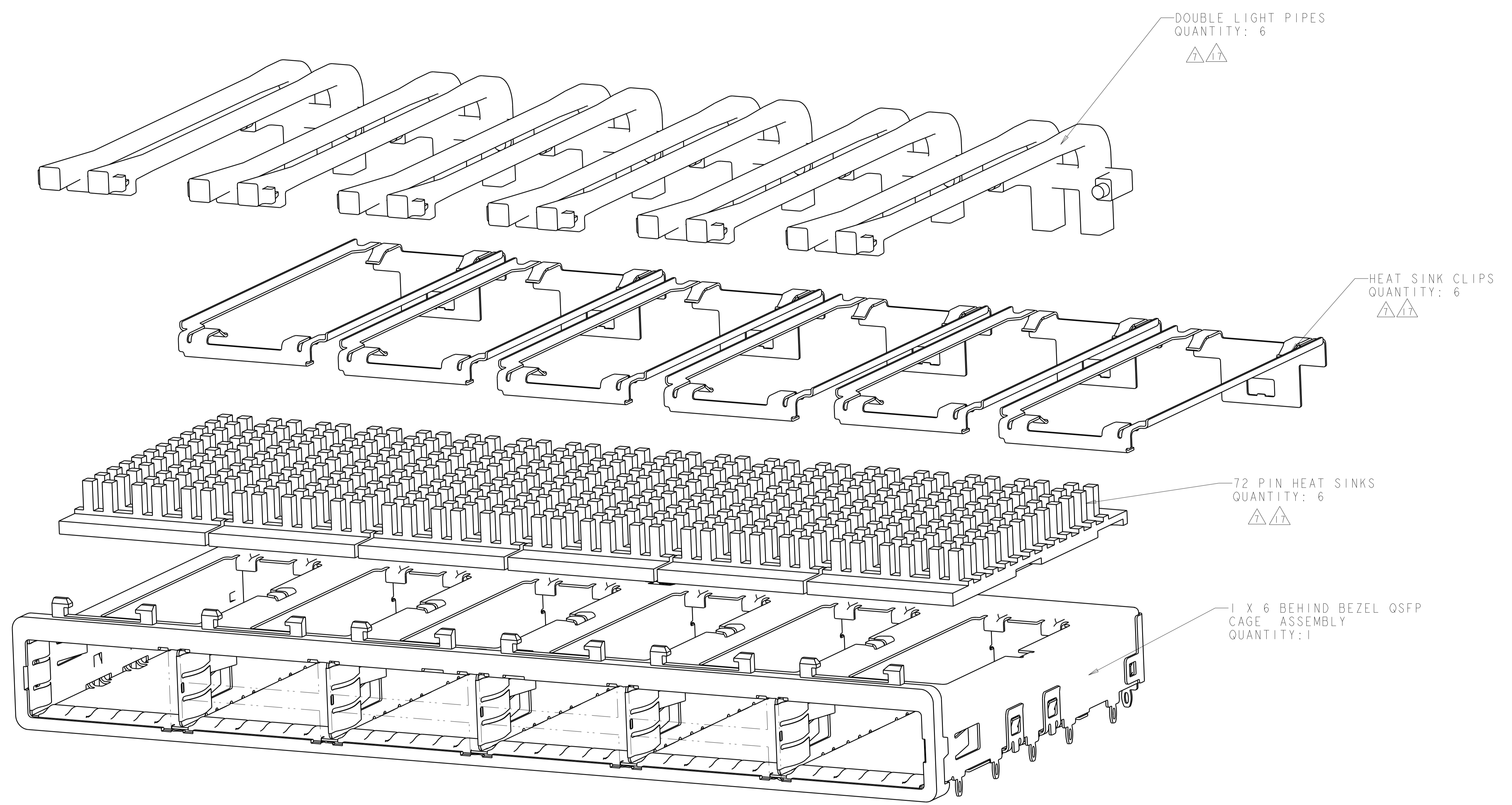

THIS DRAWING IS A CONTROLLED DOCUMENT.		DWN C. VALENTINE 18MAR2010	TE Connectivity
DIMENSIONS: mm		CHK J. PETERSON 18MAR2010	
TOLERANCES UNLESS OTHERWISE SPECIFIED: 0 PLC ± 1 PLC ±0.1 2 PLC ±0.1 3 PLC ± 4 PLC ± ANGLES ± FINISH		APVD J. PETERSON 18MAR2010	NAME 1X6 CAGE ASSEMBLY, BEHIND BEZEL, W/ 50R LIGHT PIPES AND HEAT SINKS, QSFP
MATERIAL		PRODUCT SPEC 108-2286	RESTRICTED TO
		APPLICATION SPEC 114-13218	SIZE CAGE CODE DRAWING NO A100779C=2143331
		WEIGHT	SCALE 4:1 SHEET 2 OF 6 REV B1
		Customer Drawing	

LOC	DIST	REV	DESCRIPTION	DATE	OWN	APVD
GP	00		SEE SHEET 1			

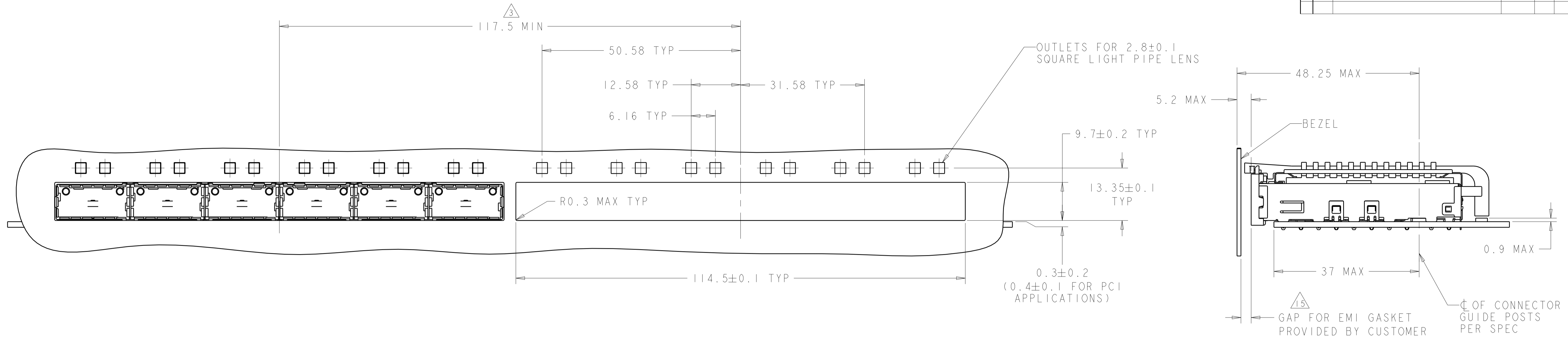

ONE SIDED CONFIGURATION WITH SQUARE LIGHT PIPES
 SCALE 2:1

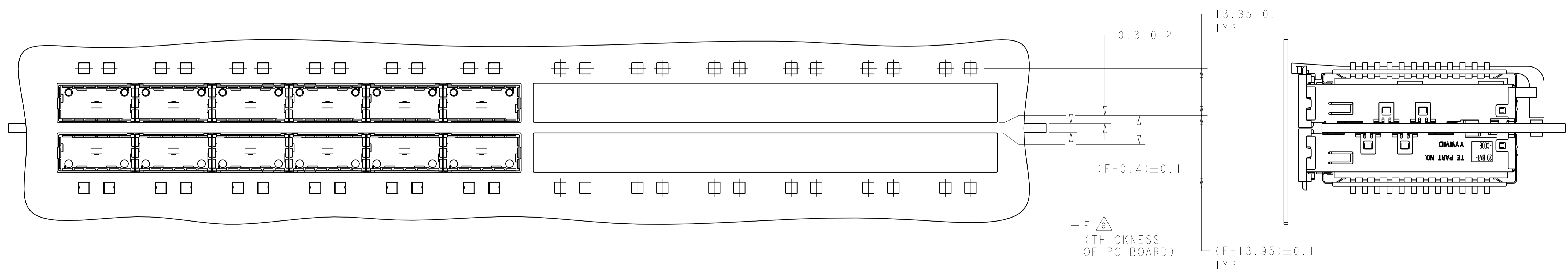

BELLY TO BELLY CONFIGURATION WITH SQUARE LIGHT PIPES
 SIMILAR TO ONE SIDED EXCEPT WHERE NOTED
 SCALE 2:1

THIS DRAWING IS A CONTROLLED DOCUMENT.

DWN: C. VALENTINE 18MAR2010	CHK: J. PETERSON 18MAR2010	APVD: J. PETERSON 18MAR2010	NAME: 1X6 CAGE ASSEMBLY, BEHIND BEZEL, W/ SQR LIGHT PIPES AND HEAT SINKS, QSFP
DIMENSIONS: mm			PRODUCT SPEC: 108-2286
TOLERANCES UNLESS OTHERWISE SPECIFIED:			APPLICATION SPEC: 114-13218
0 PLC ±	1 PLC ±0.1	2 PLC ±0.1	SIZE: A100779C=2143331
3 PLC ±	4 PLC ±	ANGLES ±	RESTRICTED TO: -
MATERIAL: -	FINISH: -	WEIGHT: -	SCALE: 4:1 SHEET 3 OF 6 REV: B1

Customer Drawing

LOC	DIST	REV	DATE	BY	APPD
GP	00				
REVISIONS					
		DESCRIPTION	DATE	BY	APPD
		SEE SHEET 1			

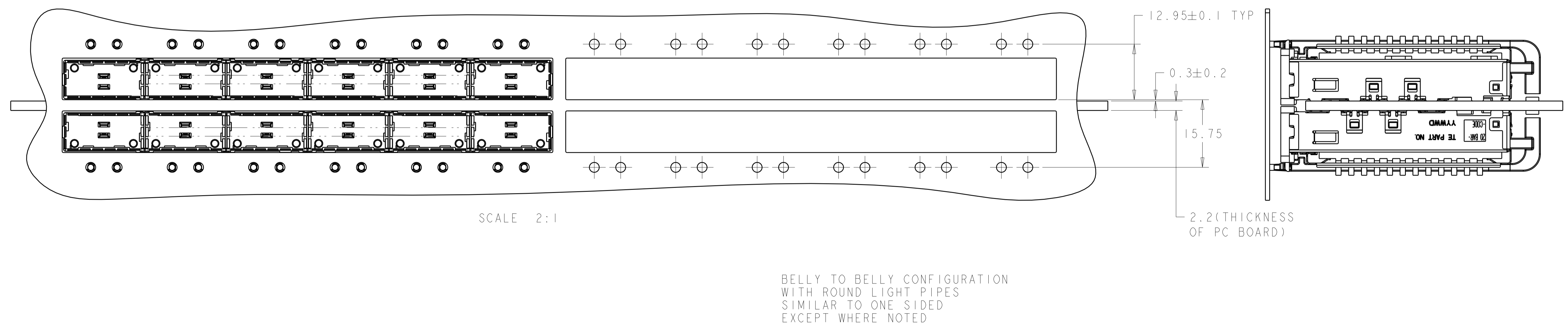
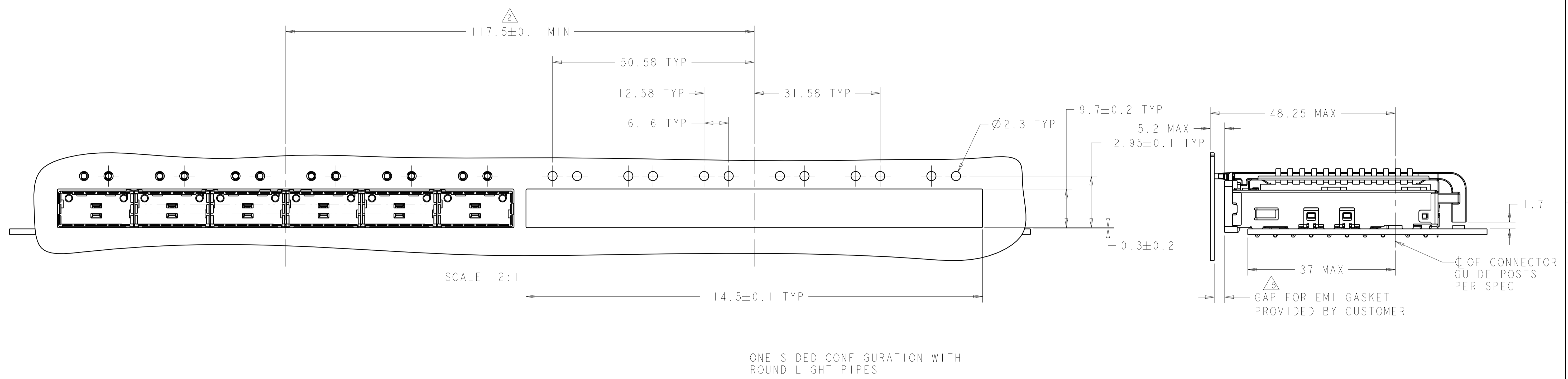

THIS DRAWING IS A CONTROLLED DOCUMENT.		OWN C. VALENTINE 18MAR2010	TE Connectivity
DIMENSIONS:		CHK J. PETERSON 18MAR2010	
mm	TOLERANCES UNLESS OTHERWISE SPECIFIED:	APVD J. PETERSON 18MAR2010	NAME 1X6 CAGE ASSEMBLY, BEHIND BEZEL, W/ SOR LIGHT PIPES AND HEAT SINKS, QSFP
0 PLC ± 1 PLC ±0.1 2 PLC ±0.1 3 PLC ± 4 PLC ± ANGLES ±	PRODUCT SPEC 108-2286 APPLICATION SPEC 114-13218 WEIGHT Customer Drawing	SIZE A100779C=2143331	RESTRICTED TO
MATERIAL	FINISH	SCALE 3:1	SHEET 4 OF 6 REV B1

LOC	DIST	REV	DATE	BY	APPV
GP	00				
REVISIONS					

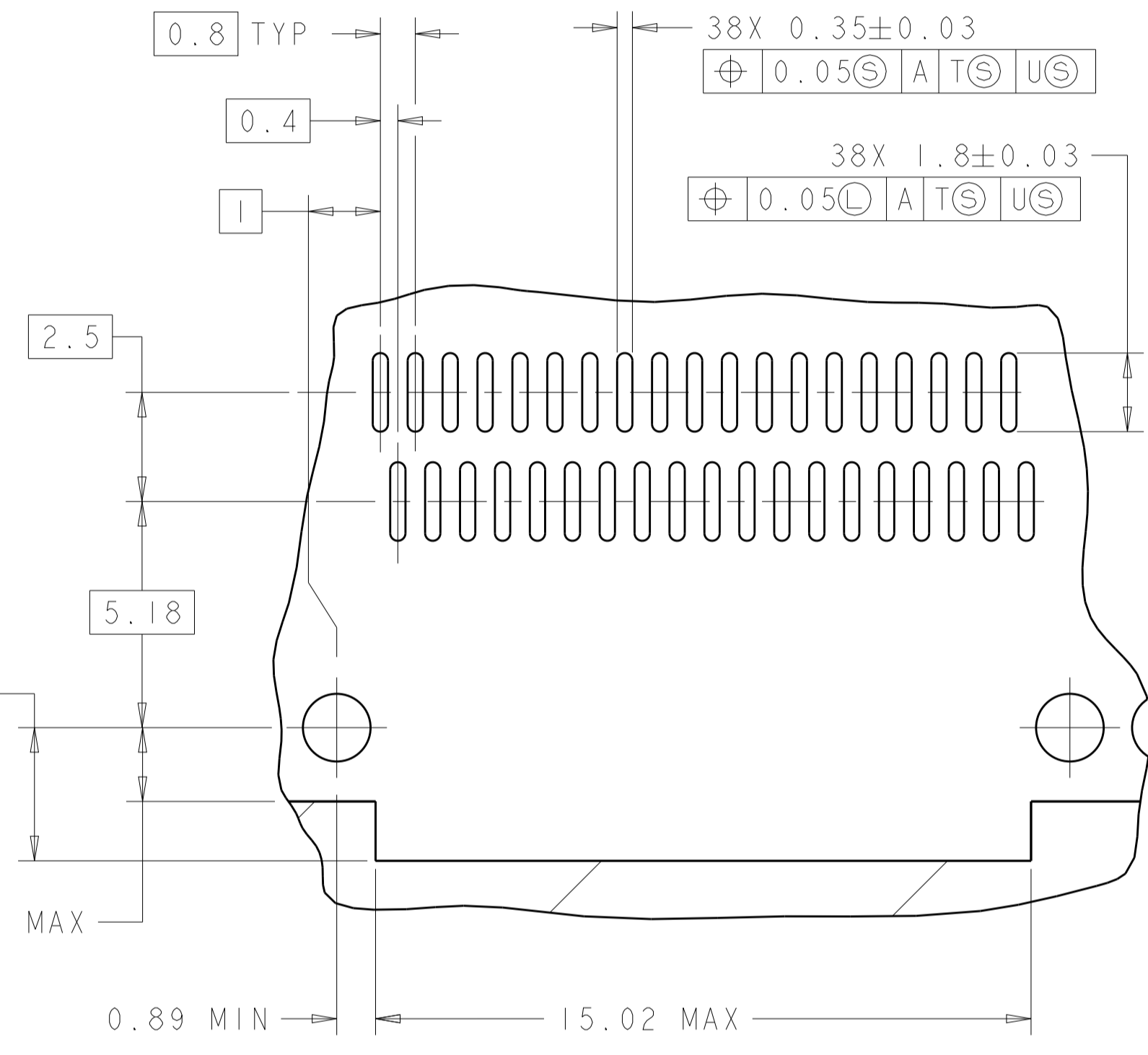
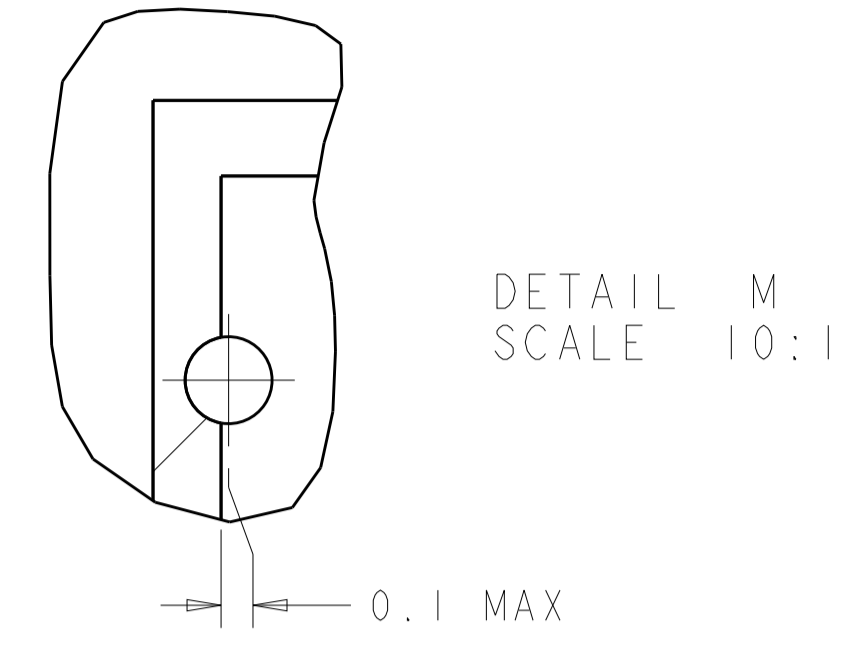
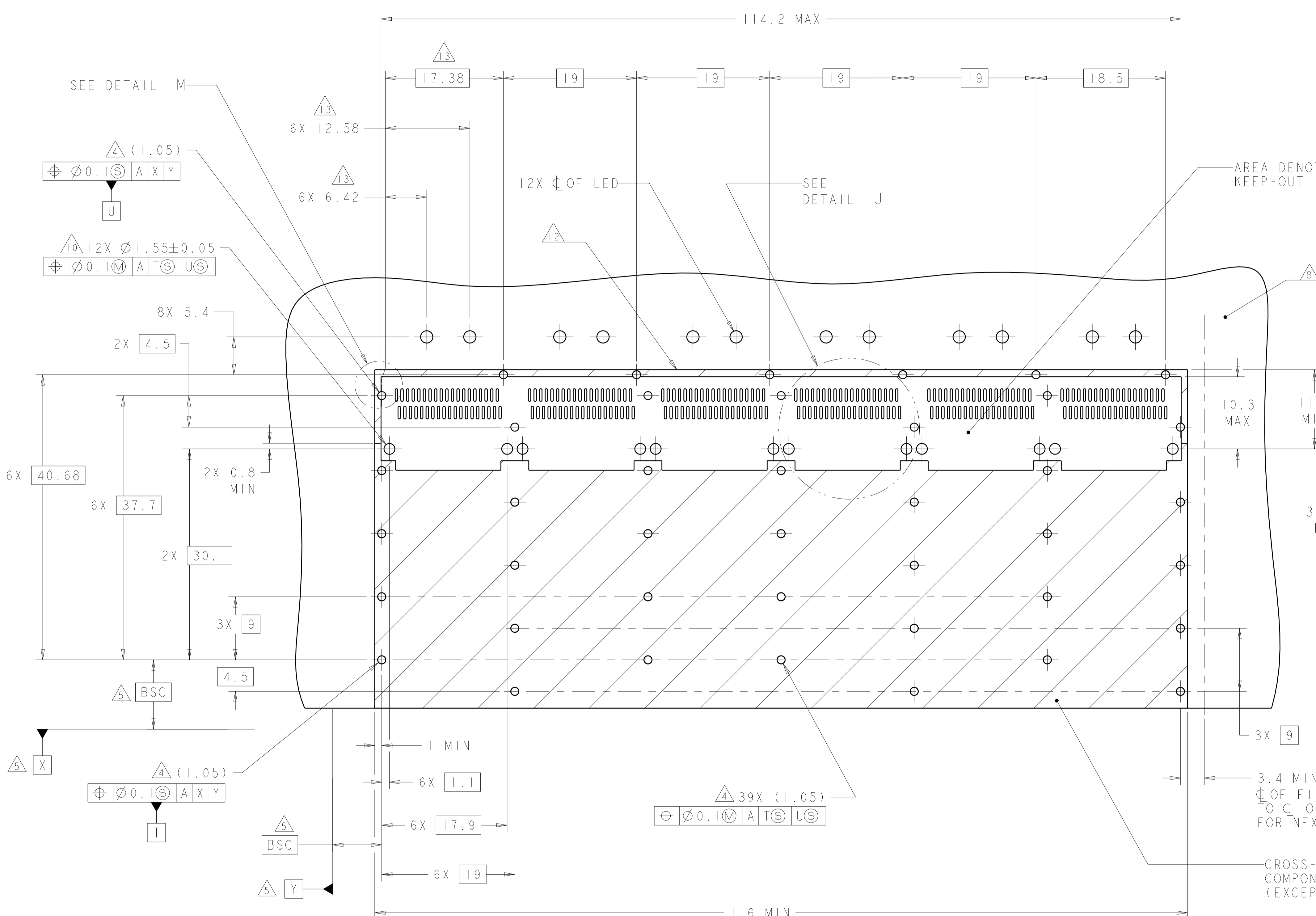

RECOMMENDED PC BOARD LAYOUT
 SINGLE SIDE MOUNT CONFIGURATION
 SCALE 3:1

AREA DENOTES COMPONENT
 KEEP-OUT (TRACES PERMITTED)

3.4 MIN
 CL OF FINAL ROW OF HOLES
 TO CL OF FIRST ROW OF HOLES
 FOR NEXT ADJACENT CAGE

CROSS-HATCHED AREA DENOTES
 COMPONENT AND TRACE KEEP-OUT
 (EXCEPT CHASSIS GROUND)

THIS DRAWING IS A CONTROLLED DOCUMENT.		OWN C. VALENTINE 18MAR2010	NAME 1X6 CAGE ASSEMBLY, BEHIND BEZEL, W/ SOR LIGHT PIPES AND HEAT SINKS, QSFP
DIMENSIONS: mm		CHK J. PETERSON 18MAR2010	PRODUCT SPEC 108-2286
TOLERANCES UNLESS OTHERWISE SPECIFIED:		APVD J. PETERSON 18MAR2010	APPLICATION SPEC 114-13218
0 PLC ±	1 PLC ±0.1	2 PLC ±	3 PLC ±
4 PLC ±	5 PLC ±	6 PLC ±	ANGLES ±
MATERIAL	FINISH	WEIGHT	RESTRICTED TO
		Customer Drawing	SCALE 4:1 SHEET 5 OF 6 REV B1

LOC	DIST	REVISIONS			
GP	00	REV	DATE	BY	APPD
-	-	SEE SHEET 1	-	-	-

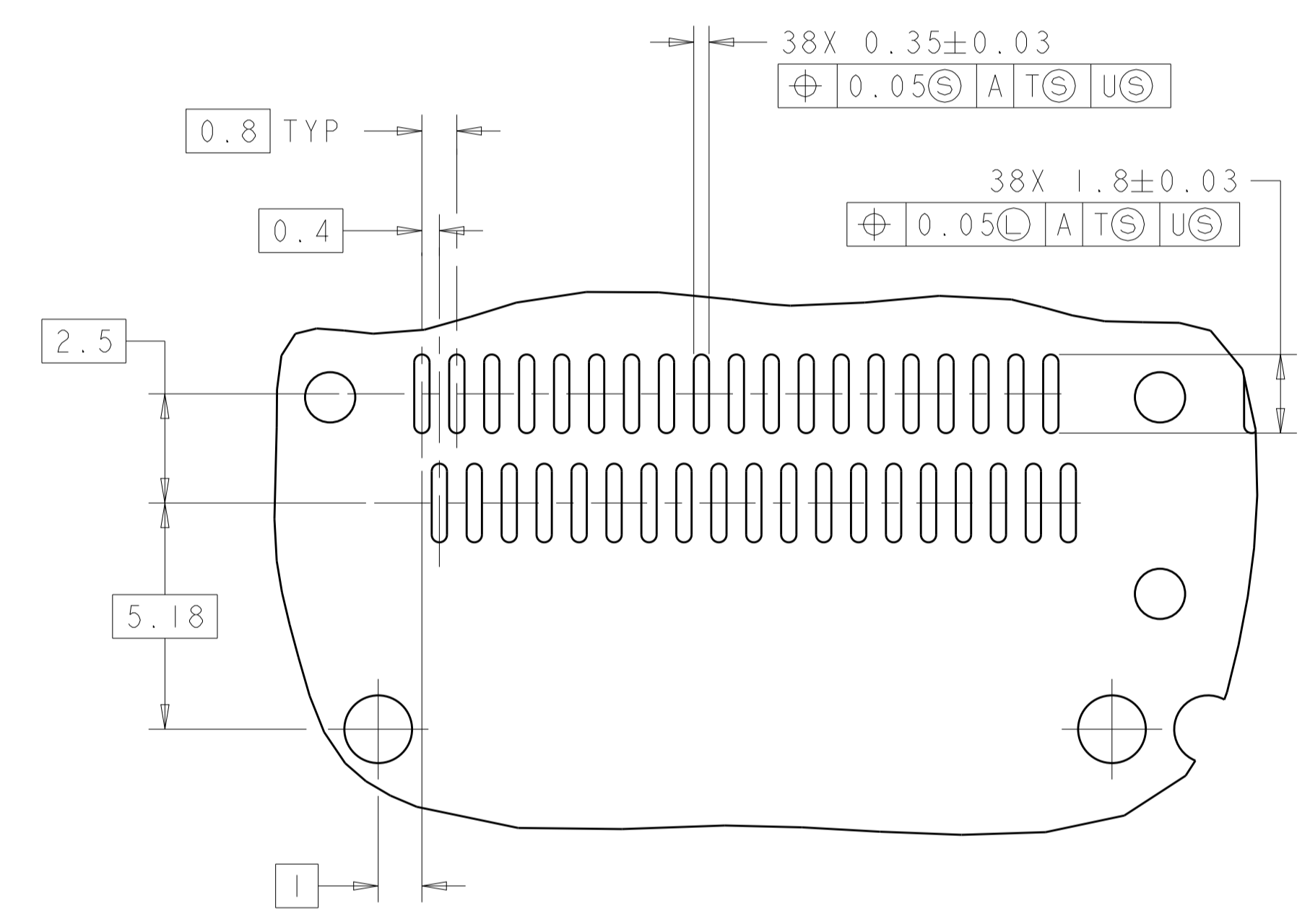
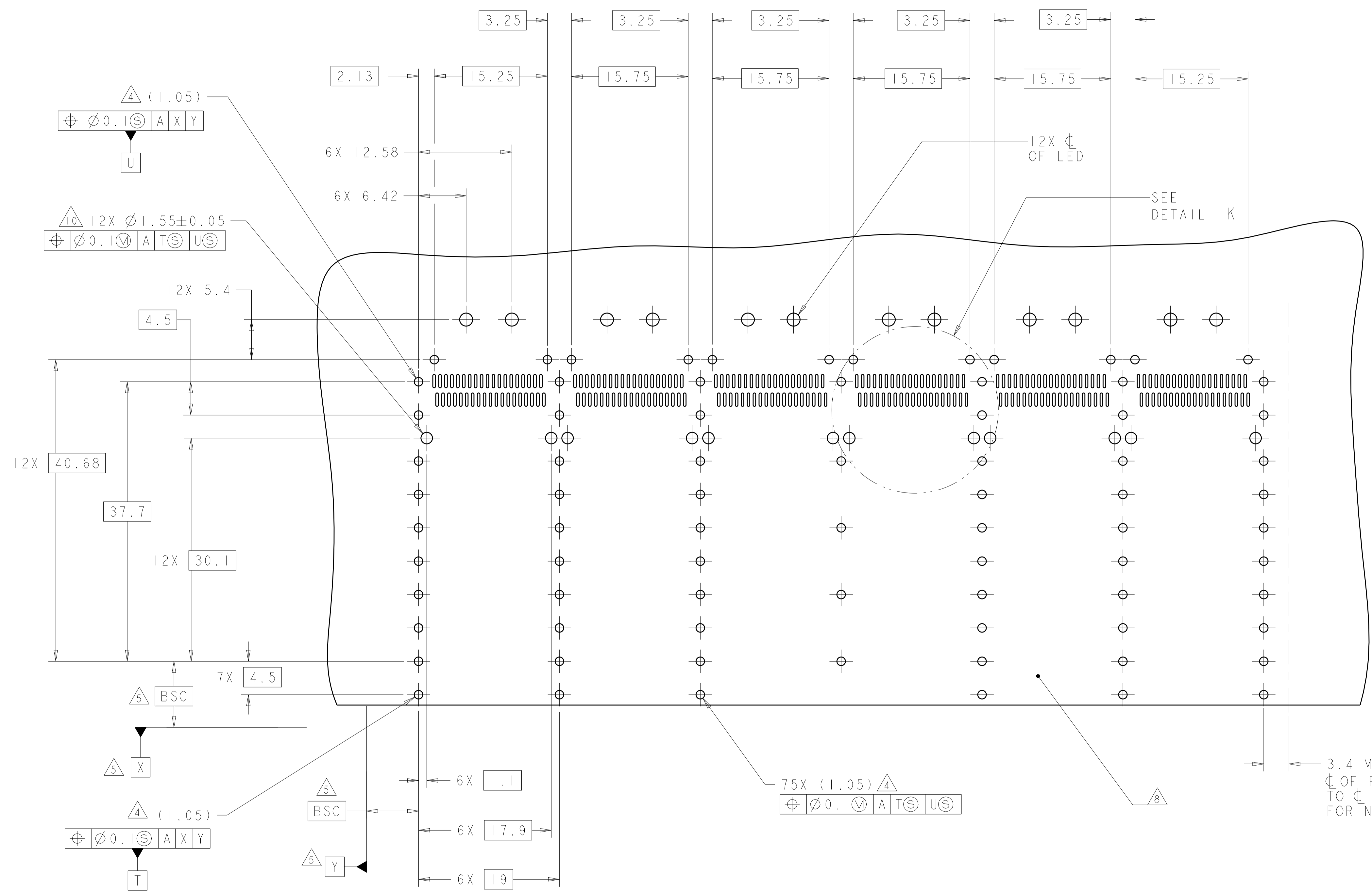

DETAIL K
 6 PLACES
 SCALE 8:1

RECOMMENDED PC BOARD LAYOUT
 BELLY TO BELLY CONFIGURATION
 SEE SHEET 4 FOR COMPONENT AND TRACE KEEP-OUTS
 SCALE 3:1

THIS DRAWING IS A CONTROLLED DOCUMENT.		OWN C. VALENTINE 18MAR2010	TE Connectivity
DIMENSIONS: mm		CHK J. PETERSON 18MAR2010	
TOLERANCES UNLESS OTHERWISE SPECIFIED:		APVD J. PETERSON 18MAR2010	NAME 1X6 CAGE ASSEMBLY, BEHIND BEZEL, W/ SOR LIGHT PIPES AND HEAT SINKS, QSFP
0 PLC ±0.1	1 PLC ±0.1	PRODUCT SPEC 108-2286	SIZE A100779C=2143331
2 PLC ±0.1	3 PLC ±0.1	APPLICATION SPEC 114-13218	RESTRICTED TO
4 PLC ±0.1	ANGLES ±0.1	WEIGHT	SCALE 4:1 SHEET 6 OF 6 REV B1
MATERIAL	FINISH	Customer Drawing	

X-ON Electronics

Largest Supplier of Electrical and Electronic Components

Click to view similar products for [I/O Connectors](#) category:

Click to view products by [TE Connectivity](#) manufacturer:

Other Similar products are found below :

[571763P](#) [72.250.1628.2](#) [72.250.2428.2](#) [74720-0505](#) [76.350.0729.0](#) [76871-1403](#) [FCN-244F080-G/1](#) [FCN-260A9920](#) [MP-5T180MUNNA-005](#)
[PCR-E36PM](#) [PCS-XE26MA+](#) [G38A71314B](#) [1571250010](#) [157-22500-3](#) [MS3471L14-19P L/C](#) [91-569786-35H](#) [172501-4002](#) [172501-6002](#)
[FCN-260C008-A/L0](#) [FCN-260C024-AL0](#) [FCN-261Z008](#) [2000314-1](#) [200331-1](#) [PCR-E36FC+](#) [PCS-E28FS+](#) [PCS-XE26SLFD+](#) [PCS-](#)
[XE26SLFDT+](#) [G730VID08BDC24](#) [HDMR-29-01-S-SM-TR](#) [U90B2054081210](#) [UE86K842720321](#) [38113800006](#) [DP3AR020WQ1R200](#)
[Z4.102.0680.0](#) [500-1040](#) [500-1052](#) [500-1054](#) [ZP-4008-66L](#) [0709821002](#) [10-565995-597N](#) [DX40-20P\(55\)](#) [5554841-1](#) [U90B3054061110](#)
[U65-E04-4020](#) [ZPF000000000097891](#) [557-262M2-06C](#) [747360449](#) [10099439-003C-TRLF](#) [10137239-0021LF](#) [E9320-001-01](#)